

PHIL'S X-CARVE WASTE BOARD DESIGN

(REVISED 4/17/2017)

SHEET 1
OVERALL ASSEMBLY LAYOUT

SHEET 2
PLATE TO EXTRUSION BASE HOLES
T-RAIL AND MDF PLANK MOUNTING HOLES

SHEET 3
20MM X 20MM EXTRUSION BASE LAYOUT
2.00 X 3.00 X .25 Y BRACING

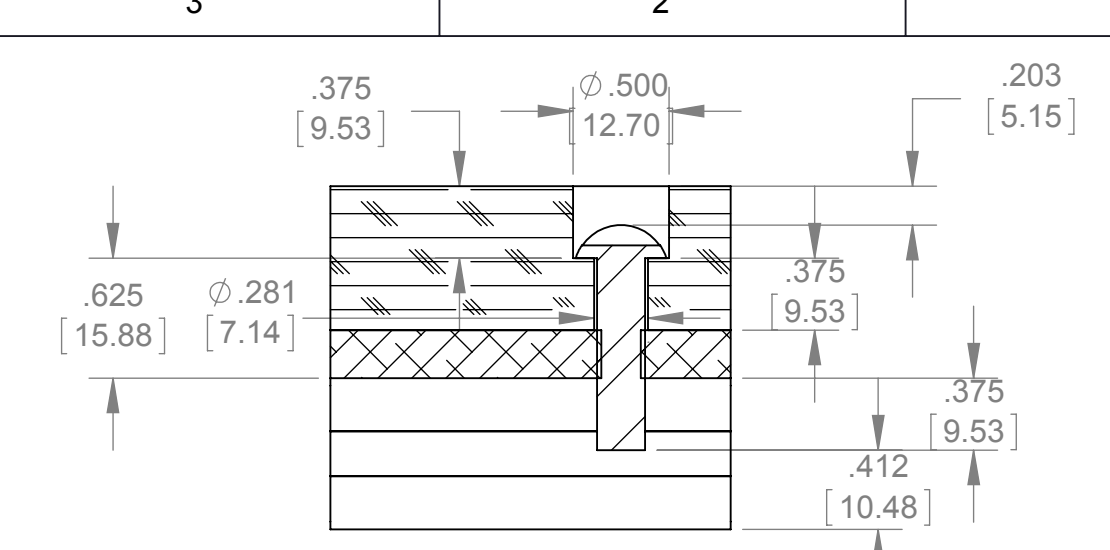

SECTION A-A
SCALE 1 : 1

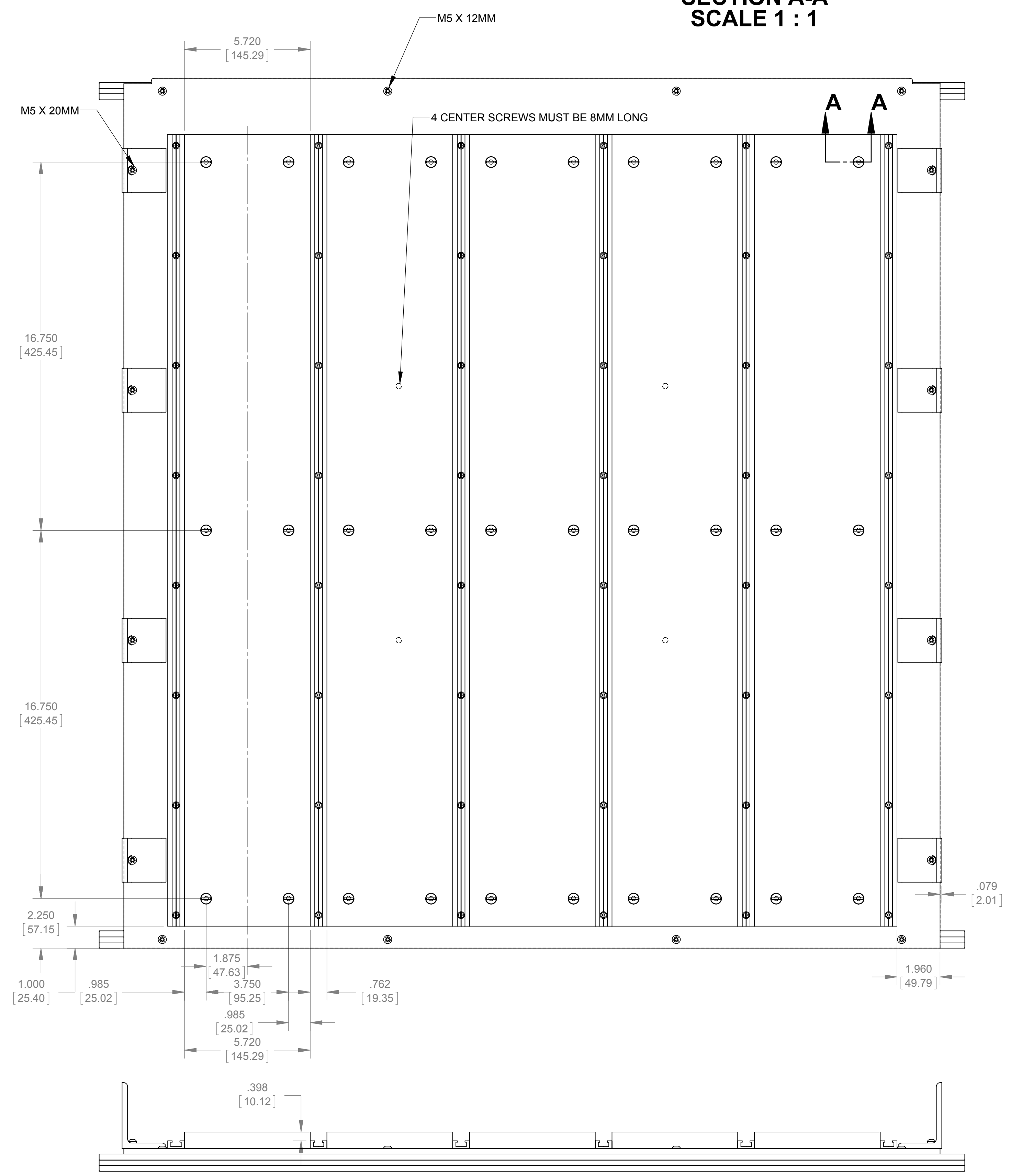

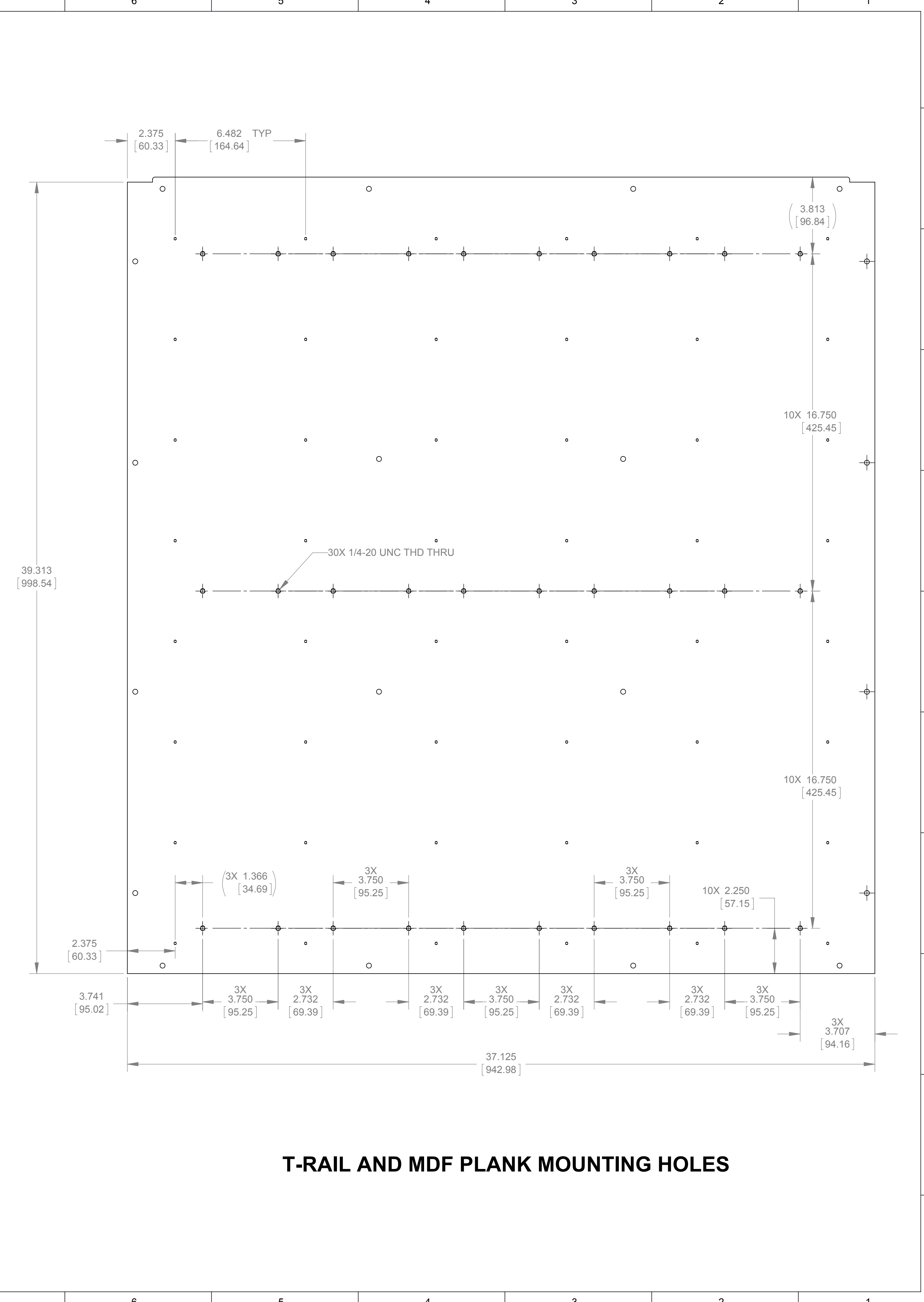
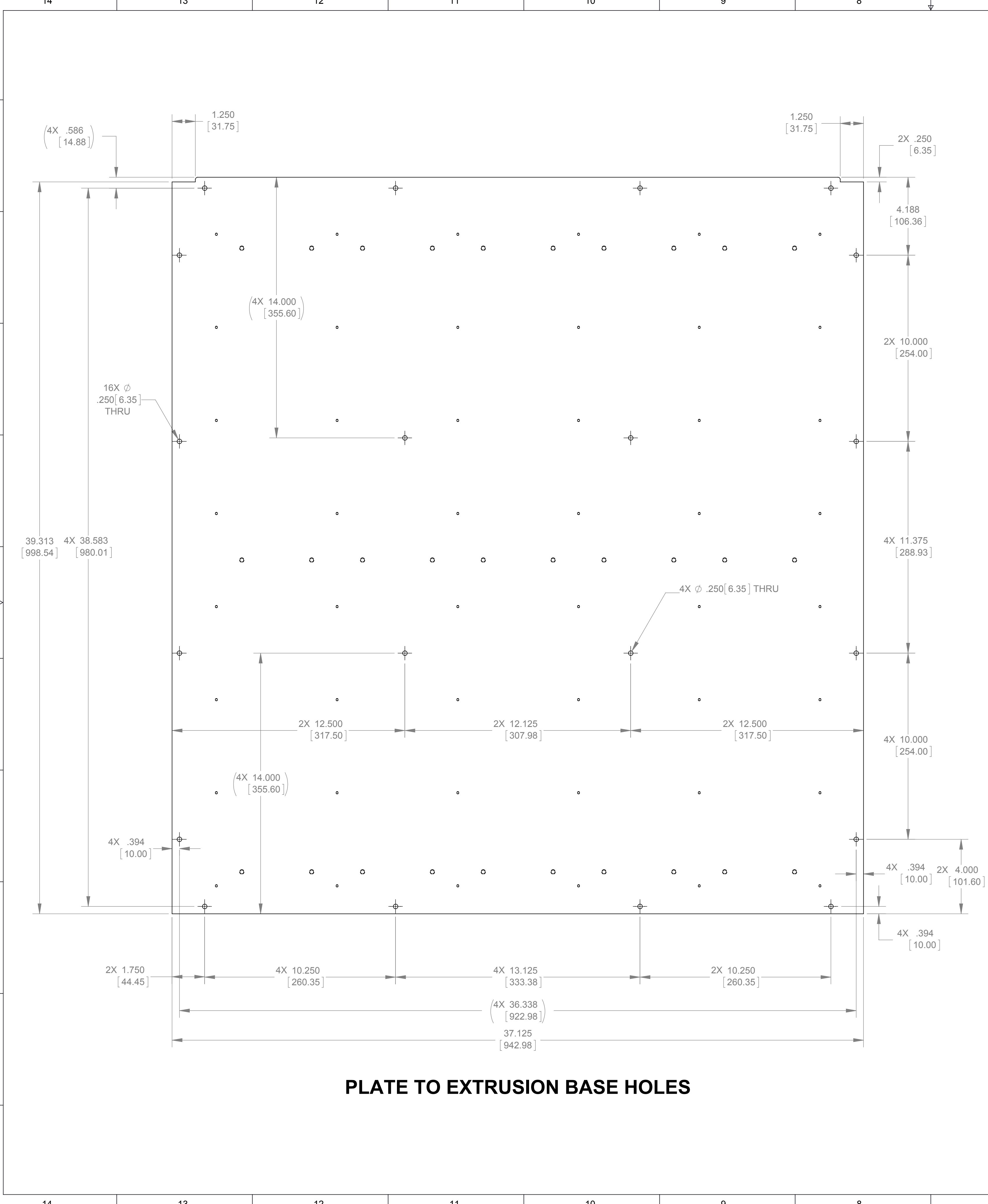

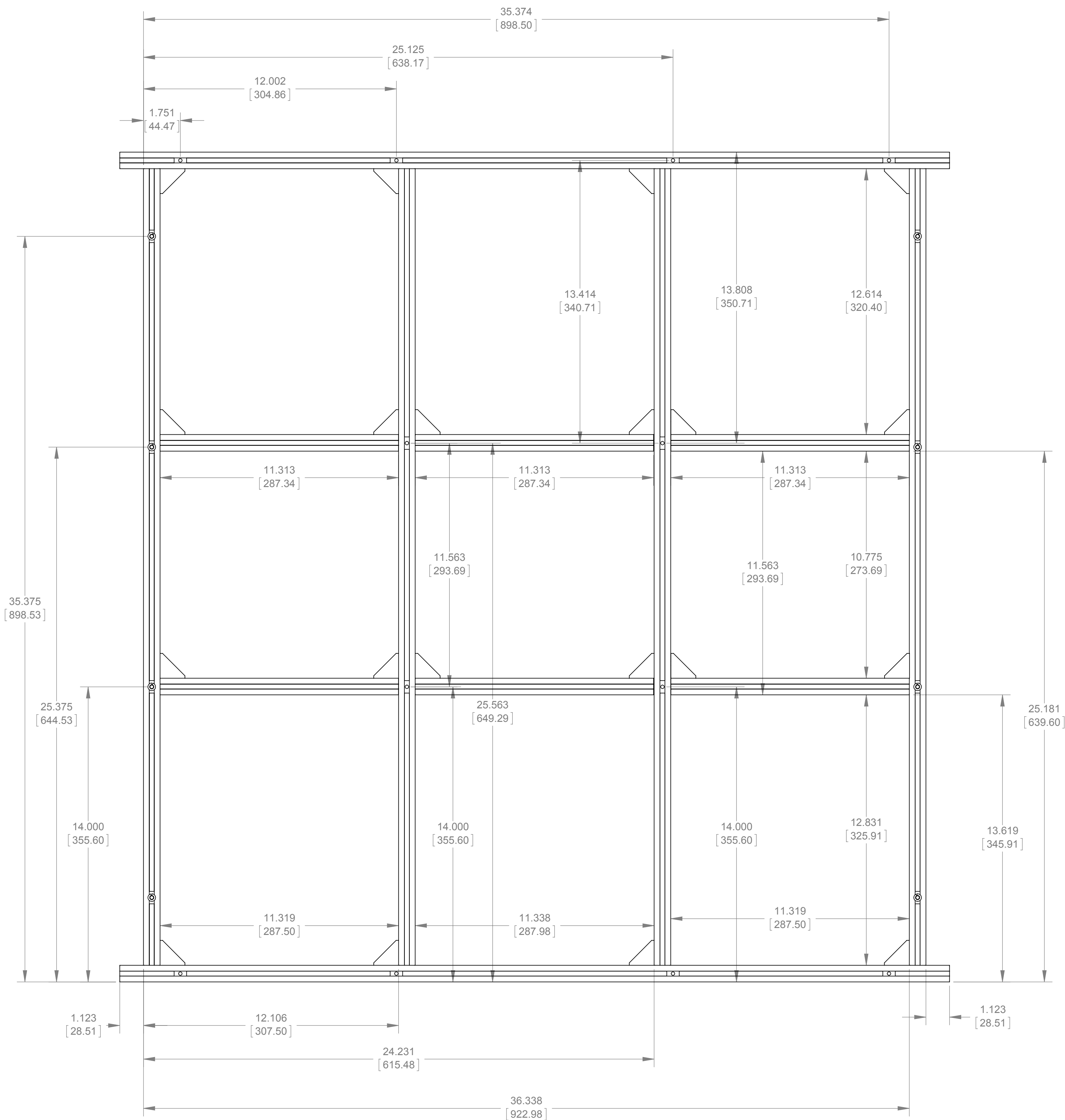

20MM X 20MM EXTRUSION BASE LAYOUT

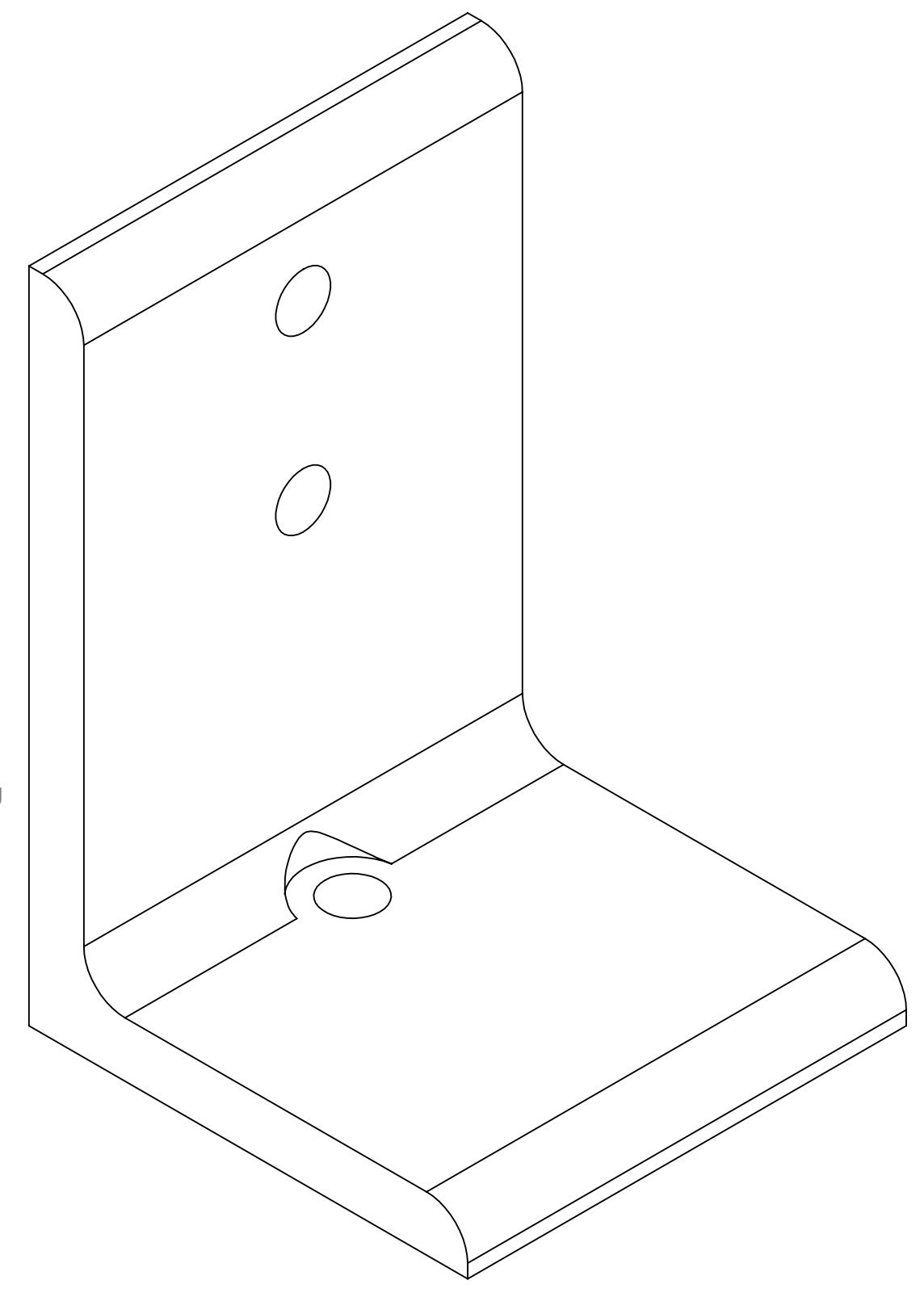
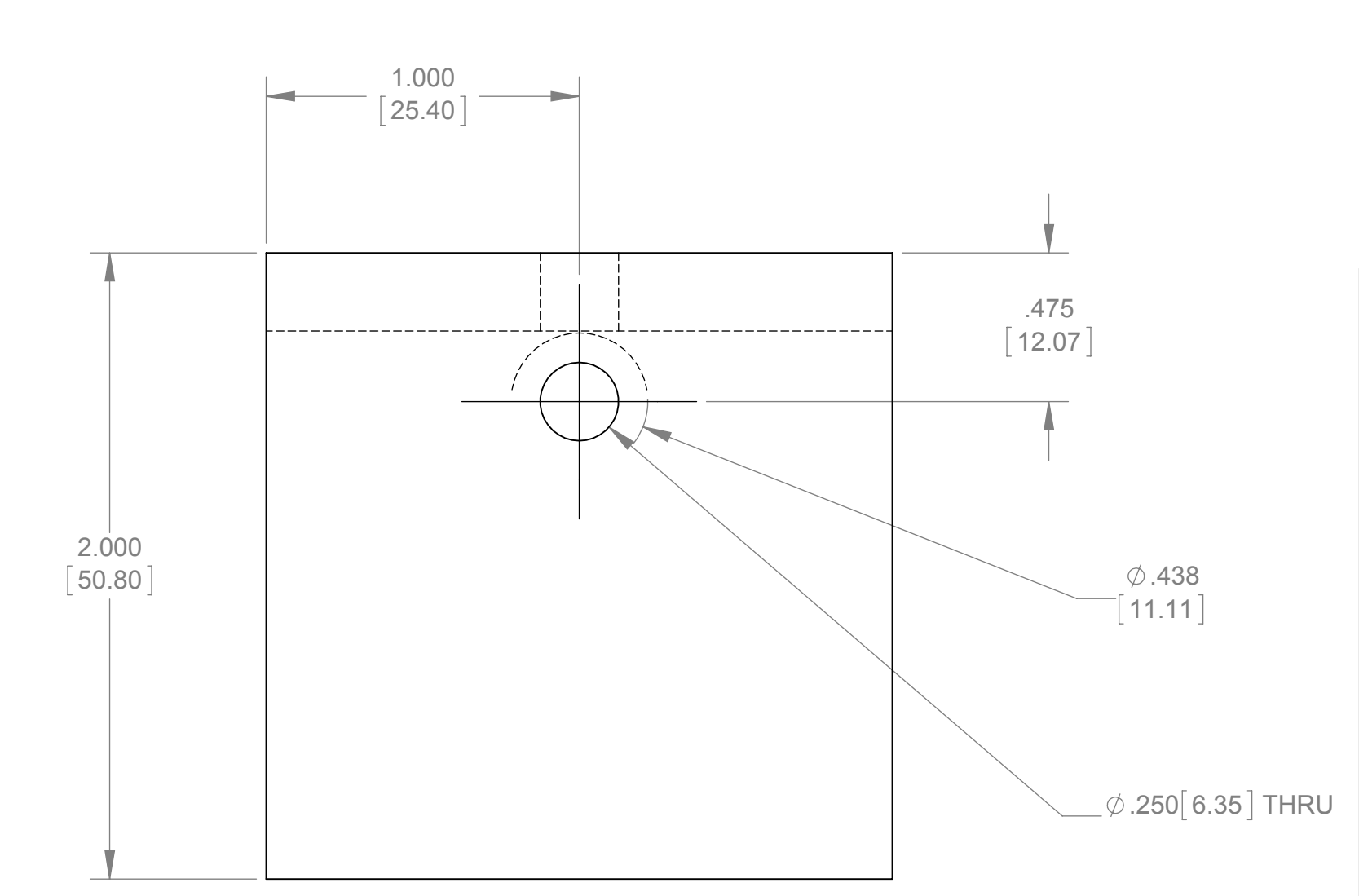
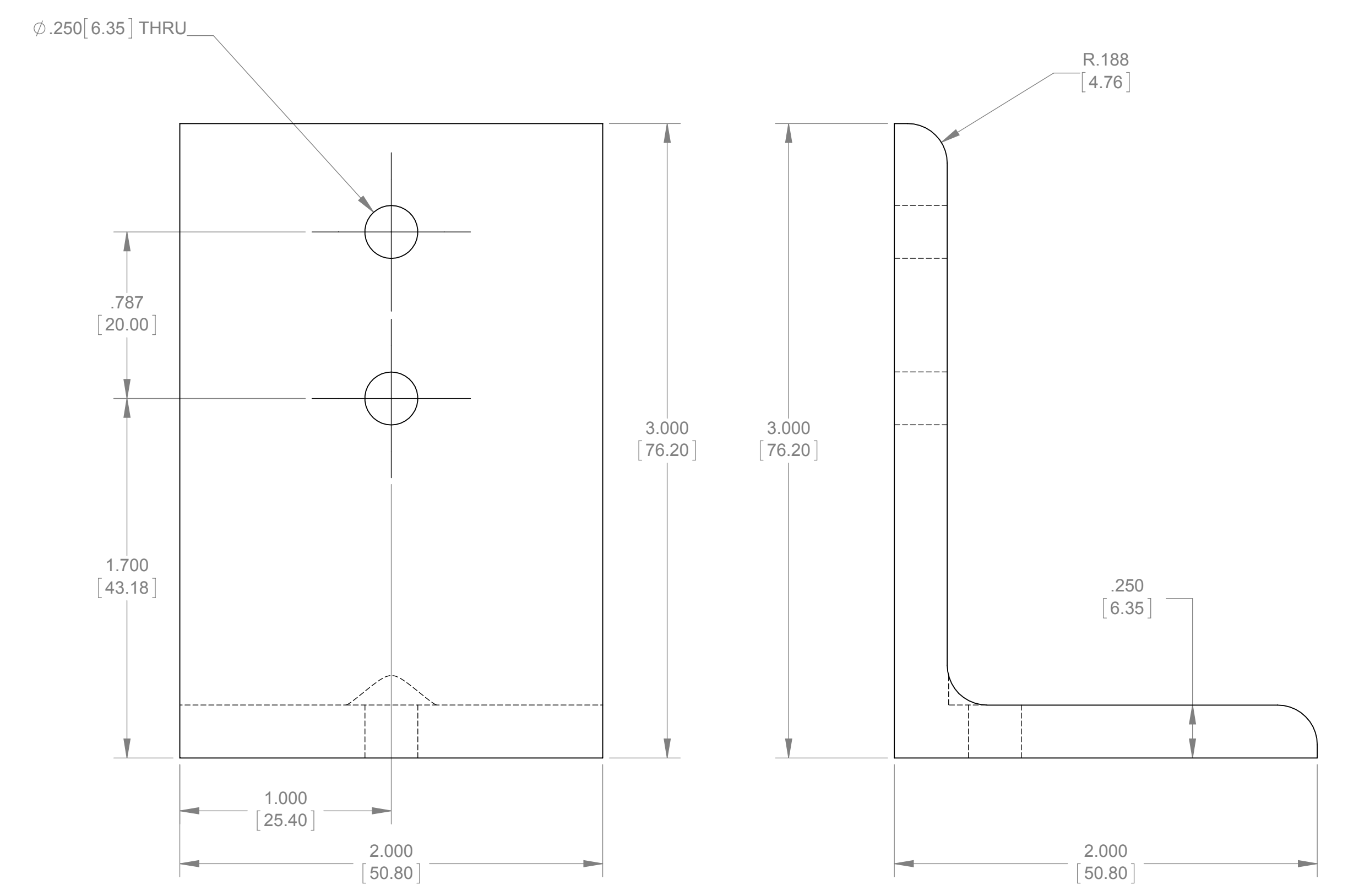

2.00 X 3.00 X .25 Y BRACING