



BUILDING STANDARDS ADVISORY

Subject Bedroom Windows	Approved by 	Advisory Number A-15 1 of 4
	Effective Date July 2001	NBC 1995 References(s) 9.7.1., 9.32.2.2.

Compliance with *The Uniform Building and Accessibility Standards Act* (the UBAS Act) and regulations is addressed in this advisory. NBC 1995 means the National Building Code of Canada 1995 as adopted by regulations under the UBAS Act. Words in italics, other than Act titles, are defined in the NBC 1995.

Note: This advisory applies to bedroom windows in *buildings* that fall under Part 9 of the NBC 1995. **The target date for full application to building permits and new installations throughout Saskatchewan is October 1, 2001.** For those jurisdictions where this advisory differs from previous interpretations, advance notice should be provided to local builders and suppliers.

REQUIREMENTS OF THE NBC 1995

The requirements for bedroom windows address three separate issues.

Light and View of the Outdoors (Article 9.7.1.2.) — The minimum window glass area for a bedroom in a *building of residential occupancy*, with or without electrical service, is 5% of the *floor area* served. This requirement makes the room useable for at least part of the day, even in *buildings* where electrical services are not available, and enhances the well-being of occupants by providing visual contact with the outside and reducing the likelihood of adverse psychological effects from lack of connection with the outdoors. A skylight may be used to provide the required glass area.

Natural Ventilation (Article 9.32.2.2.) — The minimum unobstructed openable ventilation area for a bedroom is 0.28 m² (3.0 ft²), unless adequate year-round mechanical ventilation is provided. Natural ventilation is typically provided in a bedroom by the window. Mechanical ventilation must:

- meet the requirements of Subsection 9.32.3. during the heating season, and
- meet the requirements of Sentence 9.32.2.1.(2) during the non-heating season (when the heating system would not be in operation), if natural ventilation is not provided.

Emergency Escape (Articles 9.7.1.3. and 9.7.1.4.) — Unless a bedroom has a door that leads directly to the *building* exterior, or the *suite* is *sprinklered*, each bedroom must have at least one outside window openable from the inside without the use of tools or special knowledge. This window must provide an unobstructed opening with a minimum area of 0.35 m² (3.77 ft²), and no dimension less than 380 mm (15 in.). As shown in Figure 1, a window opening of 380 mm x 380 mm does not provide the required area.

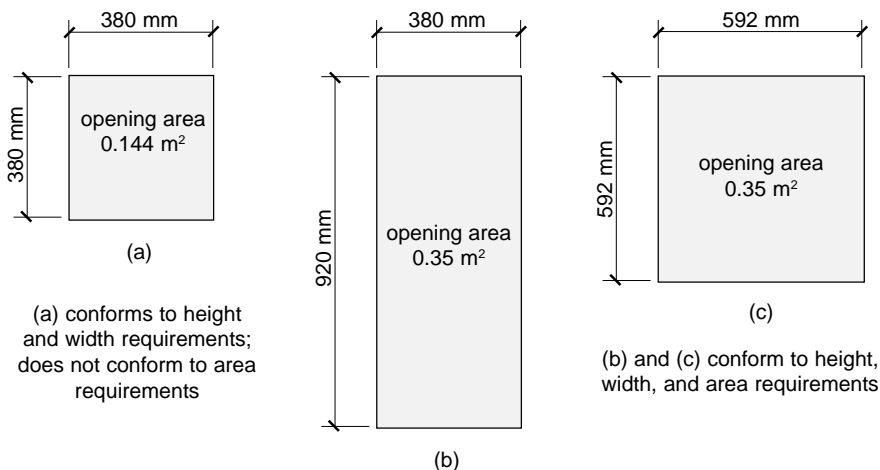



Figure 1

As shown in Figure 1, a window opening of 380 mm x 380 mm does not provide the required area.

This requirement is specifically intended to provide occupants with a means of escape in an emergency situation when the use of normal *building exits* is prevented. Although bedroom windows are not considered to be ordinary escape routes, using them in an emergency has saved many occupants.



BUILDING STANDARDS ADVISORY

Subject Bedroom Windows	Approved by 	Advisory Number A-15 2 of 4
	Effective Date July 2001	NBC 1995 References(s) 9.7.1., 9.32.2.2.

The unobstructed opening must be measured between the window components (sash, jamb, sill, opening mechanism, etc.) with the window in the fully open position (Figure 2). It is not simply the dimensions of the rough opening or the glass area. A test for the required minimum opening is the ability to pass a prism of the required cross-sectional area and minimum dimensions through the opening (Figure 3).

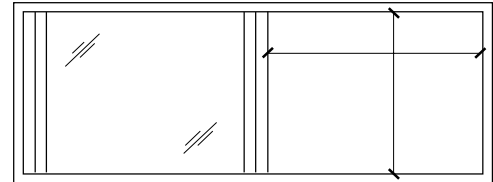

Figure 2

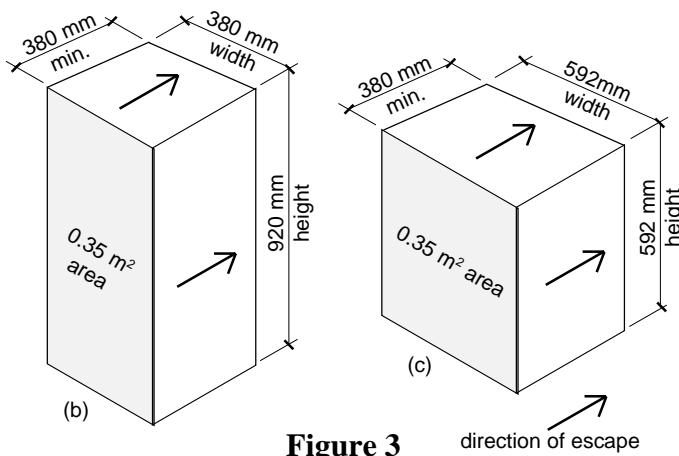

Figure 3

There is some belief that the intent of this requirement is for fire fighters' access. In the NBC 1995, requirements specifically intended for fire fighters' access (Articles 9.9.9.1. and 3.2.5.1.) require unobstructed openings be at least 1 000 mm (39.4 in.) or 1 100 mm (43.3 in.) high, respectively, by 550 mm (21.7 in.) wide. This size is specified to accommodate a fire fighter wearing self-contained breathing apparatus. The minimum size of opening required by Article 9.7.1.3. would not be sufficient to serve as an access for fire fighters. During a fire, fire fighters sometimes create designed draft situations to suppress fires and control smoke and gases. This is done by

opening holes in the *building* envelope, and possibly placing fans to create a mechanical draft situation. Although breaking a window is obviously the easiest way to open such a hole, nothing suggests that Article 9.7.1.3. is intended to provide these openings.

There is no set maximum sill height for bedroom windows. Therefore, it is possible to install a window or skylight that satisfies the requirements, but defeats their intent when the sill is so high that it cannot be reached for escape purposes. It is recommended that the sills of windows intended for use as emergency escape be not higher than 1.5 m (5.0 ft) above the floor. When it is unavoidable to have a sill height higher than 1.5 m, access to the window should be improved by some means, such as built-in furniture installed below the window (Figure 4).

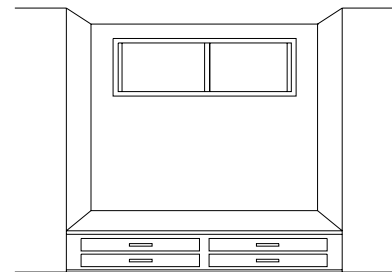

Figure 4

Window Opening into a Window-Well (Article 9.7.1.4.)

When a window required by Article 9.7.1.3. opens into a window-well, the clearance between the window and the window-well must be at least 550 mm (21.7 in.). When the window sash swings open towards the window-well, the operation of the sash must not reduce the clearance in a manner that would restrict escape in an emergency situation. Window-wells can interfere with escape if too little space is provided outside the window. Although the required clearance is measured from the window to the window-well, the clearance with the window in the open position is the more critical dimension to provide for the occupants' safety.



BUILDING STANDARDS ADVISORY

Bedroom Windows	Approved by <i>Margaret Kuzylek</i>	Advisory Number A-15 3 of 4
	Effective Date July 2001	NBC 1995 References(s) 9.7.1., 9.32.2.2

WINDOW TYPES

Awning

The use of awning windows in bedrooms has caused concern when applying Article 9.7.1.3. Awning windows (Figure 5) swing open on their horizontal axis at the top of the frame or at an intermediate mullion. The opening hardware for an awning window typically extends between the middle of the sill and the middle of the window sash. It obstructs an occupant's escape. Only very large awning windows will provide an opening at the side of the hardware that will meet the NBC 1995 requirements.

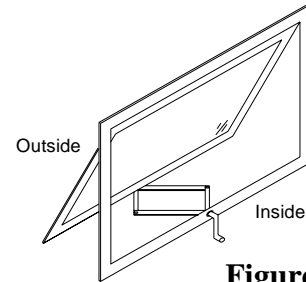

Figure 5

Although the opening hardware is usually designed to be detached from awning windows, detaching the hardware is not considered part of the normal opening operation. A person needs special knowledge to use the release mechanism, because it is hidden from plain view, requires the user to be familiar with how it functions, and requires dexterity to operate. Quick-release hardware, intended to improve an occupant's ability to release the hardware, does not appear to be commonly used. Even if quick-release hardware could eliminate the need for special knowledge, when the opening hardware is detached (or light enough to be broken away) so that the opening is large enough to be a means of escape, the window is no longer held in an open position. The window becomes the obstruction.

In general, awning windows do not meet the intent for a means of escape and do not provide compliance with Article 9.7.1.3. For exceptional circumstances, specific approvals by the authority having jurisdiction or local building official should be obtained.

Casement

Casement windows (Figure 6) open on their vertical axis and usually have opening hardware installed at the bottom of the window. Since this hardware obstructs an occupant's escape, the opening should be measured to the hardware. In addition to the opening hardware, casement windows usually have latches opposite the hinge. These latches should be within reach of children who are expected to escape on their own.

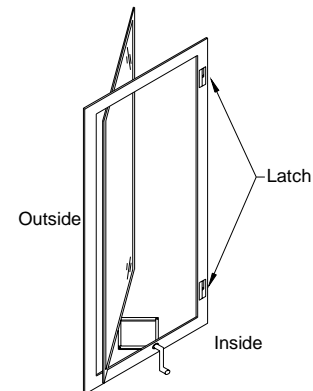

Figure 6

Casement windows come with two types of hinge hardware. The normal hardware allows the window to pivot around a vertical axis that is not at the jamb. Alternatively, egress hinge hardware hinges the window at an axis along the jamb to allow for a maximum unobstructed opening. Casement windows will satisfy the requirements of Article 9.7.1.3. when the opening is large enough to pass the prism test with the opening hardware in its most restrictive position and the window fully open.

Slider

Horizontal and vertical slider windows (Figure 7) are commonly used in residential construction. They are capable of meeting the requirements of Article 9.7.1.3. when the opening is large enough to pass the prism test. Some slider windows have the ability to flip open into the room to allow for easy cleaning. This operation requires several steps and is not considered normal opening of the window. The unobstructed opening should be measured when the window is in the fully open position.



BUILDING STANDARDS ADVISORY

Bedroom Windows	Approved by <i>Margaret Kuzylek</i>	Advisory Number A-15 4 of 4
	Effective Date July 2001	NBC 1995 References(s) 9.7.1., 9.32.2.2

Full Vent Inswing Awning

Full vent inswing awning windows (Figure 8) swing open on their vertical axis at the top of the frame or at an intermediate mullion. This type of window latch does not use an opening operator and is able to swing open without restriction or be held partially open with intermediate catches. It swings in towards the user and does not restrict the clearance when opening into a window-well. This type of window is typically marketed as a “basement” window because it swings inward and the size of the opening is not restricted by the opening mechanism. If there is a catch available to hold the window in the open position, this type of window can satisfy the requirements of Article 9.7.1.3.

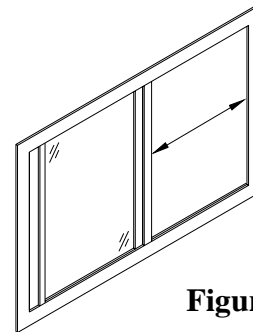

Figure 7

Hopper

Hopper windows (Figure 9) swing open on their horizontal axis at the bottom of the frame or at an intermediate mullion. They have a latch to hold them closed and do not typically come with an opening operator. This allows them to swing open freely or be held partially open with intermediate catches. With typical hopper windows, a bedroom occupant would have to crawl over the glass area to escape. Hopper windows that swing to an open, fully vertical position without intermediate catches could meet the requirements of Article 9.7.1.3., but hopper windows are not commonly used for bedrooms.

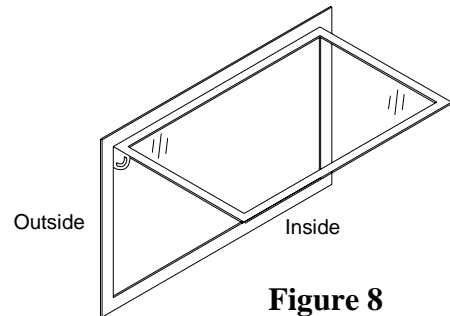

Figure 8

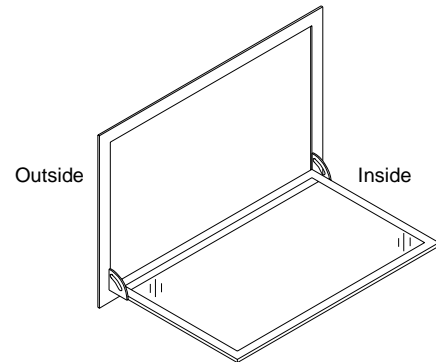

Figure 9

OTHER CONSIDERATIONS

Ice build-up that prevents or restricts opening a window is a concern with any type of window. With improved heating and ventilating systems in houses and improved window construction, ice build-up appears to be less of a concern that it may have been in the past.

Latches incorporated on the inside of the window frame are not considered to require special knowledge to release. These latches are typically engaged, for security or to ensure the window is shut tightly, and released as part of the normal opening process.

Insect screens, security bars, grilles or similar devices should be easily removable or releasable from the inside without the use of a key, tool, or special knowledge.

Children who are expected to escape through a bedroom window on their own should be taught how to open the window and remove or release any screens or bars that may be installed. Home fire drills should include practice in using the window as a means of escape. For those people who are too young or physically infirm to escape on their own through a window, special precautions such as additional smoke detectors in the bedroom to assist with early detection or relocating their bedroom to the first storey to assist with their rescue, might be considered.