



## **Bottle Cooler**

### **Service, Installation and Care Manual**

**Please read this manual completely before attempting to install or operate this equipment.  
Notify carrier of damage! Inspect all components immediately. See page 4.**



**IMPORTANT INFORMATION  
READ BEFORE USE  
PLEASE SAVE THESE INSTRUCTIONS!**

## COMMERCIAL REFRIGERATOR SAFETY

**Your safety and the safety of others are very important.**

We have provided many important safety messages in this manual and on your appliance. Always read and obey all safety messages.

**Our product instructions will be uploaded on our company official website.**



This is the Safety Alert Symbol. This symbol alerts you to potential hazards that can kill or injure you and others. All safety messages will follow the Safety Alert Symbol and either the words "DANGER", "WARNING" or "CAUTION".



Danger means that failure to heed this safety statement may result in severe personal injury or death.



Warning means that failure to heed this safety statement may result in extensive product damage, serious personal injury, or death.



Caution means that failure to heed this safety statement may result in minor or moderate personal injury, or property or equipment damage.

All safety messages will alert you to what the potential hazard is, tell you how to reduce the chance of injury, and let you know what can happen if the instructions are not followed.

If the supply cord is damaged, it must be replaced by the manufacturer, its service agent or similarly qualified persons in order to avoid a hazard.

This appliance is not intended for use by persons (including children) with reduced physical, sensory or mental capabilities, or lack of experience and knowledge, unless they have been given supervision or instruction concerning use of the appliance by a person responsible for their safety.

Children should be supervised to ensure that they do not play with the appliance.

This appliance can be used by children aged from 8 years and above and persons with reduced physical sensory or mental capabilities or lack of experience and knowledge if they have been given supervision or instruction concerning use of the appliance in a safe way and understand the hazards involved. Children shall not play with the appliance. Cleaning and user maintenance shall not be made by children without supervision.

Keep the appliance and its cord out of reach of children less than 8 years.

Do not store explosive substances such as aerosol cans with a flammable propellant in this appliance.

The appliance use flammable insulation blowing gas C5H10, disposal of the appliance shall in accordance with the regulations of local authorities.

The key for appliance electric box should be safe kept by qualified persons in order to avoid a hazard



Warning; Risk of fire / flammable materials

**WARNING:** Keep ventilation openings, in the appliance enclosure or in the built-in structure, clear of obstruction.

**WARNING:** Do not use mechanical devices or other means to accelerate the defrosting process, other than those recommended by the manufacturer.

**WARNING:** Do not damage the refrigerant circuit.

**WARNING:** Do not use electrical appliances inside the food storage compartments of the appliance, unless they are of the type recommended by the manufacturer.

Handling, moving, and use of the refrigerator or freezer to avoid either damaging the refrigerant tubing, or increasing the risk of a leak

L'opération, le mouvement et l'utilisation du réfrigérant ou le congélateur doivent éviter les dommages du tuyau réfrigérant ou le risque de la fuite.

Caution – Risk of Fire or Explosion due to Flammable Refrigerant Used. Follow Handling Instructions Carefully in Compliance with U.S. Government Regulations.

Component parts shall be replaced with like components and that servicing shall be done by factory authorized service personnel, so as to minimize the risk of possible ignition due to incorrect parts or improper service.

Les pièces de rechange doivent être remplacées par les composants relatifs et les opérations doivent être faites par les professionnels afin de minimaliser le risque d'allumage à cause des parts incorrects ou des opérations impropres.

CAUTION – Risk Of Fire Or Explosion Due To Puncture Of Refrigerant Tubing; Follow Handling Instructions Carefully. Flammable Refrigerant Used

**DANGER:** Risk of child entrapment. Before you throw away your old refrigerator or freezer:

Take off the doors

Leave the shelves in place so that children may not easily climb inside



# CONTENTS

SPECIFICATIONS.....2

CONGRATULATIONS ON YOUR NEW COOLER.....2

INSTALLATION.....3

ELECTRICAL CONNECTION.....3

OPERATION INSTRUCTIONS.....3

STORAGE OF PRODUCT.....3

DEFROSTING THE CABINET.....3

MAINTENANCE.....3

OPERATION.....4

TROUBLE SHOOTING.....6

DISPOSAL.....6

SPECIAL POINTS TO NOTE.....6

CIRCUIT DIAGRAM.....7

STANDARD WARRANTIES.....8

All rights reserved. Reproduction without written permission is prohibited.



is a registered trademark of The Entree Company.

# SPECIFICATION

MODEL#	V/Hz/Ph	AMPS	STORAGE CAPACIT	HP	BTU	CHARGE OZ	SHIP WEIGHT LBS	NEMA PLUG
BST-36-Q	115/60/1	1.8	10	3/8	2000	2.12	161	5-15P
BST-50-Q	115/60/1	3.0	15	1/2	3200	2.47	310	5-15P
BST-65-Q	115/60/1	3.0	20	1/2	5400	3.17	353	5-15P
BST-94-Q	115/60/1	3.3	26	1/2	7600	3.53	439	5-15P

# CONGRATULATIONS ON YOUR NEW COOLER

Note these instructions apply to all coolers. Installations of equipment may not exactly correspond to your model.



## INSTALLATION

Make sure that the cooler is not damaged on arrival. Your supplier must be notified of any transport damage, within 24 hours of delivery. The cooler should be placed in a warm, dry room, with suitable ventilation. Place the cooler in such a way, as to allow the free circulation of air around it. That is, with at least four (4) inches space all around it. Never place the cooler in strong sunlight. The cooler be placed on a level surface. Make sure that it does not rock. If the cooler has been stored or transported cold, it must not be started before the compressor is judged to have reached a temperature at least 40°F. It is recommended to clean up the cooler before starting it.

## ELECTRICAL CONNECTION

The cooler must be connected to a socket with the correct voltage/frequency, as show on the nameplate. The standard for U.S. is 115V/60HZ. Voltage variations of  $\pm 10\%$  are acceptable. Greater variations can damage the cooler, and in such cases the factory warranty is not valid. In the case of extreme voltage variation, above or below the standard, your local supplier will be able to advise you, what to do.

This also applies, if a new cooler is replaced, which did not have such protection. The purpose of extra protection, is to protect the user from dangerous electric shocks, in the case of defect.

## OPERATION INSTRUCTIONS

The temperature in the cooler is automatically regulated by a readjusted thermostat.

The position of the cooler, the ambient temperature, the number of times the lid is opened and for how long the lid is opened, all these factors affect the temperature in the cooler, which should therefore not be placed in sunlight or closed to a heat-radiating surface.

If your cooler is fitted with a lock, the key should be kept out of the reach of children. If your new cooler is to replace an older one, which is not in use any more, you should remove the lock mechanism, on the old one, before disposing it.

## STORAGE OF FOOD

The cooler is only designed as a conserver, and is the not suited to cold freeze food product. In other words, only refrozen food must be placed in the cooler. Next to that the cooler must not be filled beyond the height limit of the contents line, or in cases where there is no such line, to within 100mm below the lid. This is to ensure the product temperature less than 34°F.

## DEFROSTING THE CABINET

In the course of time, a frost layer will be naturally formed within the cooler.

When this layer is  $\frac{1}{8}$ " to  $\frac{1}{4}$ " thick, the cabinet should be defrosted the following way:

- remove the plug from the socket;
- open the lid and leave it open;
- loosen the frost layer using a plastic or wooden scraper.

The defrosting process can be speeded up by using bowls of hot water.

### **Never use sharp or pointed instruments**

After final defrosting, the cabinet should be cleaned as described in section: Maintenance. the cabinet should be thoroughly dried after cleaning.

## OPERATION



### CAUTION

Do not throw items into the storage area. Failure to heed these recommendations could result in damage to the interior of the cabinet.

### Refrigerated cycle

**Refrigerators:** During the refrigeration cycle, the evaporator fans will run continuously even when one or more doors are open. The door switch will activate the lights when opened.

1. Every 6 hours, the unit will turn off and to allow the evaporator coil to defrost. The controller now displays the defrost symbol. When the coil temperature reaches 41°F or after 20 minutes of defrost, the unit will turn on again.
2. Anti-condensation heaters on door frames work in conjunction with the compressor.
3. The factory setting for the temperature range is 34°F to 38°F.

## SOLID-STATE THERMOSTAT DESCRIPTIONS

### 1. FRONT PANEL COMMANDS

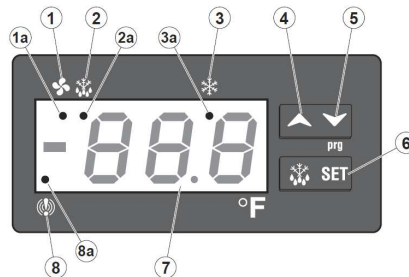

**SET:** ⑥ To display target set point; in programming mode it selects a parameter or confirms an operation.

(DEF) ② To start a manual defrost

(UP) ⑤ To view the latest alarm occurrence; in programming mode it browses the parameter codes or increases the display value

(DOWN) ④ To view the latest alarm occurrence; in programming mode it browses the parameter codes or decreases the display value

### KEY COMBINATION

+ ④+⑤ To lock & unlock the keyboard

**SET** + ⑥+⑤ To enter in programming mode

**SET** + ⑥+④ To return to the room temperature display

### 1.1 Function of LEDs

LED	MODE	FUNCTION
	ON	Compressor enabled
	Flashing	- Programming Phase (flashing with ) - Anti-short cycle delay enabled
	ON	Defrost enabled
	Flashing	- Programming Phase (flashing with ) - Drip time in progress
	ON	Fans enabled
	Flashing	Fans delay after defrost in progress.
	ON	An temperature alarm happened

## 2. MAIN FUNCTIONS

### 2.1 HOW TO SEE THE SETPOINT

1. Push and immediately release the **SET** key: the display will show the set point value. 
2. Push and immediately release the **SET** key or wait for 5 seconds to display the sensor value again.

### 2.2 HOW TO CHANGE THE SETPOINT

1. Hold the **SET** key for more than 2 seconds to change the set point value.
2. The value of the set point will be displayed and the ❄️ LED starts blinking.
3. To change the set value push the ▲ or ▼ key within 10 seconds.
4. To set a new point value, push the **SET** key again or wait 10 seconds.

### 2.3 HOW TO START A MANUAL DEFFROST

Hold the ❄️ key for more than 2 seconds and the manual defrost will start



### 2.4 HOW TO LOCK THE KEYBOARD

1. Hold the ▲ and ▼ keys for more than 3 seconds.
2. The "POF" message will be displayed and the keyboard will be locked. At this point, it will be possible only to see the set point or the MAX or Min temperature stored.
3. If a key is pressed more than 3s the "POF" message will be displayed.



### 2.5 HOW TO UNLOCK THE KEYBOARD

Hold the ▲ and ▼ keys together for more than 3s, till the "POF" message is displayed.

## 3. ALARM SIGNALS

### HOW TO SEE THE ALARM AND RESET THE RECORDED ALARM

1. Hold the ▲ or ▼ key to display the alarm signals.
2. When the signal is displayed, hold the **SET** key until the "rst" message is displayed, and push the **SET** key again. The "rst" message starts blinking and the normal temperature will be displayed.

Message	Cause	Outputs
"P1"	Room probe failure	Compressor output according to par. "Con" and "COF"
"P2"	Evaporator probe failure	Defrost end is timed
"P3"	Condenser probe failure	Outputs unchanged.
"HA"	Maximum temperature alarm	Outputs unchanged.
"LA"	Minimum temperature alarm	Outputs unchanged.
"dA"	Door open	Compressor and fans restarts
"EA"	External alarm	Output unchanged.
"CA"	Serious external alarm (i1F=bAL)	All outputs OFF.
"CSd"	Condenser alarm	All outputs OFF.

## MAINTENANCE

This cooler can be cleaned using warm water and a mild detergent. Rinse with clean water to finish off.

**Never use detergents that contain chlorine.**

The lid may be cleaned in the same way as the cooler.

If a condenser and associated fan are fitted at the back bottom of the cooler, they can gather dust and dirt. If cleaning is necessary, they should be vacuumed with a soft brush.

**Please note that the parts behind the protective grille can be hot and rotating.**

## TROUBLE SHOOTING

If you are having problems with your cooler, please check the following point before calling service personnel:

- Is the cooler connected to the power supply?
- Is the socket switch on?
- Is the fuse in the switch cabinet intact?
- Has the earth leak circuit breaker (if there is one) cut out?
- Has there been power cut?

If the cooler is in a place that is very hot or with bad ventilation, make sure to provide adequate ventilation. If the condenser mentioned in Section Maintenance is not clean, make sure to vacuum it.

If the above points have been checked and the cooler is still not working, please call service personnel. Inform them the nature of the problem, the type of cooler, serial number and item number (provided on the nameplate at the back of the cabinet).

Do not open the cabinet, as every opening hastens the thawing point. As a rule, the goods will not suffer damage at the first 12 hours. If more time passes, the goods must be moved to another cooler.

## DISPOSAL

When a worn-out cooler is to be disposed off, this must be done in a correct manner, with respect to the environment. Please be aware of the rules covering the disposal of such terms; there may be special requirements or conditions to be observed.

Information about disposal may be obtained from:

- your supplier;
- the relevant authorities (the Local Authority, environmental agencies, etc.).

## SPECIAL POINTS TO NOTE

The information contained in these instructions for use, was correct at the time of printing. On account of our constant product development, however, we reserve the right to make changes in the cooler described here. Naturally, we will attempt to keep instructions for use up to date.

If you are in doubt as to the correct use of the cooler, please contact your supplier, who will be able to advise you.

The producer is not responsible for accidents or problems, occurred as a result of wrong connection of the cooler.



# CIRCUIT DIAGRAM

MODEL: BST-36-Q / BST-50-Q / BST-65-Q

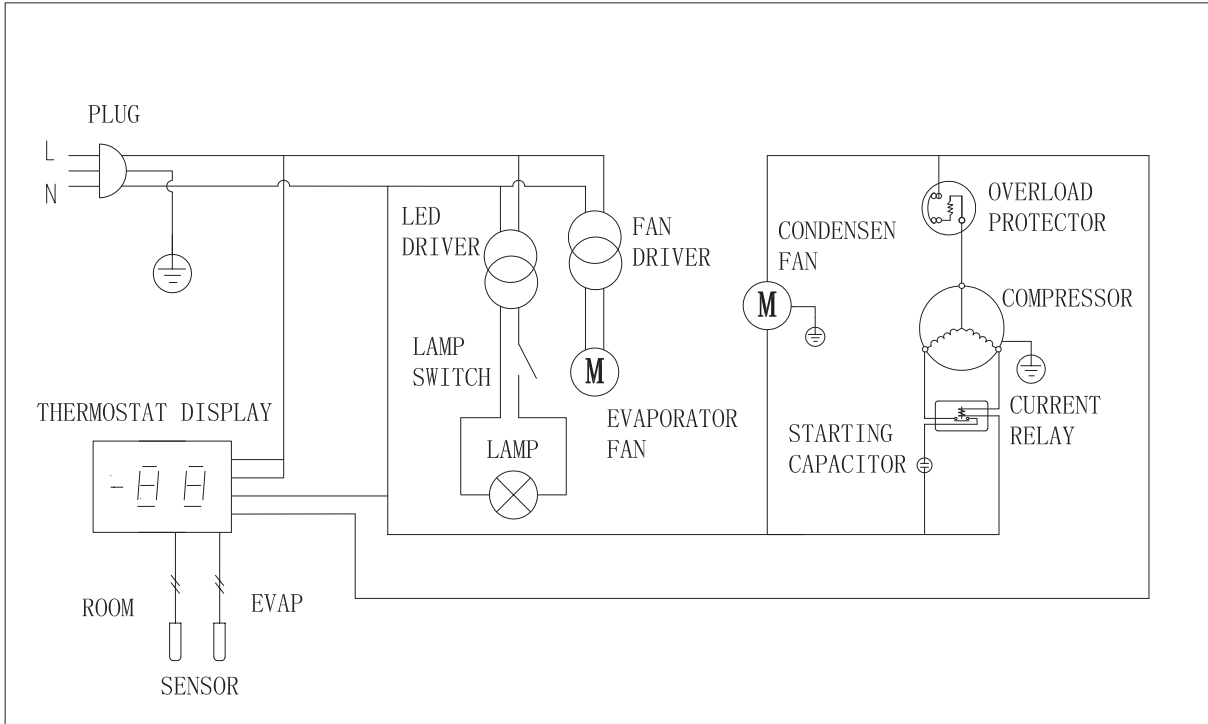

MODEL: BST-94-Q

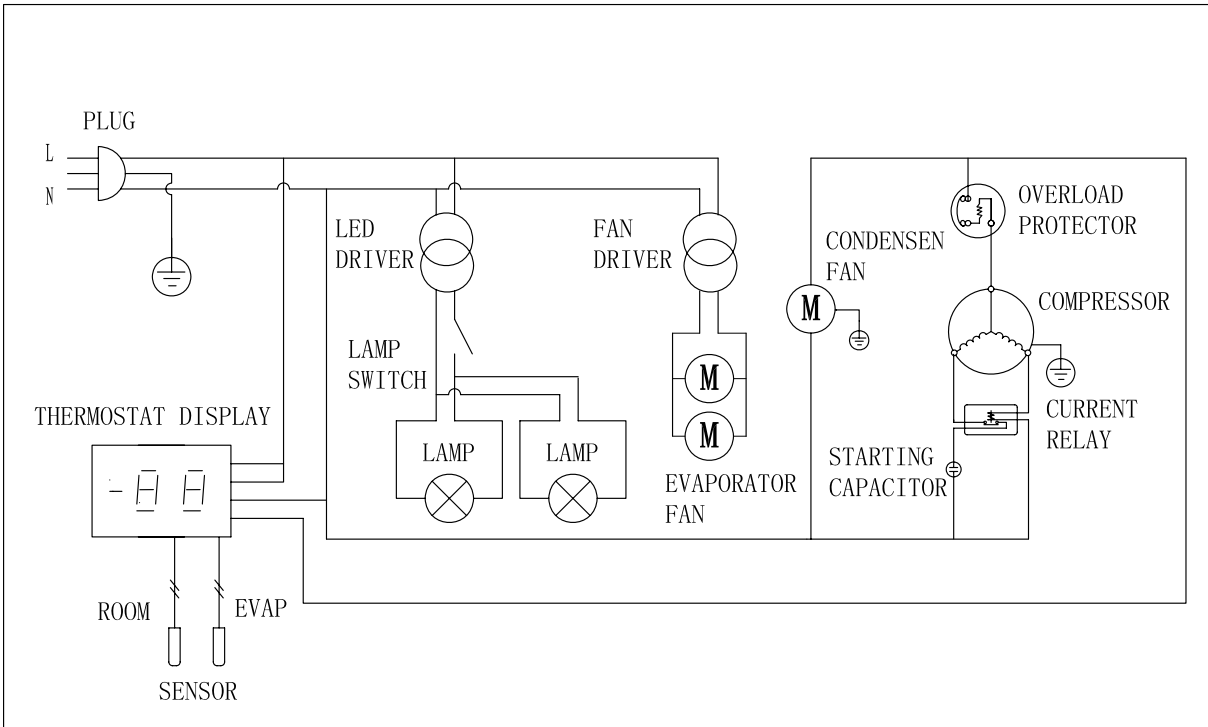

## STANDARD TWO-YEAR WARRANTY

**(TWO-YEAR PARTS & LABOR WARRANTY For products produced after serial number 1301ENTH00001.)**

ENTRÉE L.L.C. warrants to the original purchaser of every new refrigerated unit, the cabinet and all parts thereof, to be free from defects in material or workmanship, under normal and proper use and maintenance service as specified by ENTRÉE LLC and upon proper installation in accordance with the Owner's Manual supplied with each Entrée L.L.C. unit. Entrée L.L.C. obligation under this warranty is limited to a period of two (2) years from the date of original purchase or thirty 30 months after shipment date from Entree, whichever occurs first. Any model of refrigeration equipment installed in a non-permanent structure, such as a mobile kitchen and/or trailer shall have a thirty (30) days limited warranty from the date of purchase. Proof of purchase required.

Any part covered under this warranty that is determined by Entrée to have been defective within two (2) years of original purchase or thirty (30) months after shipment date from manufacturer, whichever occurs first, is limited to the repair or replacement, including labor charges, of defective parts or assemblies. The labor warranty shall include standard straight time labor charges only and the established flat rate trip charges.

Warranty does not cover standard wear parts which include door gaskets, incandescent bulbs or fluorescent bulbs, loosened fasteners of door or lid hinges. Warranty also does not cover issues caused by improper installation or lack of basic preventative maintenance which includes regular cleaning of condenser coils.

### ADDITIONAL THREE-YEAR COMPRESSOR WARRANTY

In addition to the Two (2) year warranty stated above, Entrée L.L.C. warrants its hermetically sealed compressor to be free from defects in both material and workmanship under normal and proper use and maintenance service for a period of three (3) additional years from the date of original installation but not to exceed five (5) years and three (3) months after shipment from the manufacturer. Removal or defacement of the original Serial Number or Model Number from any Unit shall be deemed to release Entree from all obligations hereunder or any other obligations, express or implied.

IF THE CUSTOMER IS USING A PART THAT RESULTS IN A VOIDED WARRANTY AND AN ENTREE AUTHORIZED REPRESENTATIVE TRAVELS TO THE INSTALLATION ADDRESS TO PERFORM WARRANTY SERVICE, THE SERVICE REPRESENTATIVE WILL ADVISE CUSTOMER THE WARRANTY IS VOID. SUCH SERVICE CALLS WILL BE BILLED TO CUSTOMER AT THE AUTHORIZED SERVICE CENTER'S THEN APPLICABLE TIME AND MATERIALS RATES.

If shipment of a replacement part is requested by the end user prior to the arrival in the Entree factory of the part claimed to be defective, the Original Purchaser must accept delivery of the replacement part of a C.O.D. basis, with credit being issued after the part has been received and inspected at Entree's plant and determined by Entree to be within this warranty.

Compressors determined by Entrée L.L.C. to have been defective within this extended time period will, at Entrée L.L.C. option, be either repaired or replaced with a compressor or compressor parts of similar design and capacity. The freight charges for sending a replacement compressor are not covered by this warranty. Replacement of a defective Compressor is limited to one (1) Compressor by us during the three years period.

The three (3) year extended compressor warranty applies only to hermetically sealed parts of the compressor and does not apply to any other parts or components, including, but not limited to: cabinet, paint finish, temperature control, refrigerant, metering device, driers, motor starting equipment, fan assembly or any other electrical component, etcetera.



## STANDARD TWO-YEAR WARRANTY

(TWO-YEAR PARTS & LABOR WARRANTY For products produced after serial number 1301ENTH00001.)

### 404A/134A COMPRESSOR WARRANTY

The compressor warranty detailed above will be voided if the following procedure is not carefully adhered to:

1. If the refrigerator/freezer does not cool within 1 hour/60 minutes, turn the unit off and call for service. If the refrigeration system is void of Freon and the compressor is allowed to run more than an hour damage will occur to the compressor and will cause it to fail. Failure/replacement of the compressor in this manner is not covered by this warranty.
2. Drier replacement is very important and must be changed when a system is opened for servicing. The new drier must also be the same capacity as the drier being replaced.
3. Micron level vacuums must be achieved to insure low moisture levels in the system. 500 microns or lower must be obtained.

### WARRANTY CLAIMS

All requests for must be called into 704-900-2068 to obtain and agree to service dispatch with Warranty Claim Payment Terms. All claims for labor or parts must be made directly through Entrée L.L.C.

All claims should include: Dispatch number, model number of the unit, the serial number of the cabinet, proof of purchase, date of installation, and all pertinent information supporting the existence of the alleged defect.

In case of warranty compressor, the compressor warranty form must be filled out by a qualified refrigeration technician. This form can be obtain by down load from our website: [www.entree.biz](http://www.entree.biz). This form must be emailed, in its completion, with a copy of the original proof of purchase to: [john@entree.biz](mailto:john@entree.biz).

### WHAT IS NOT COVERED BY THIS WARRANTY

Entrée L.L.C. sole obligation under this warranty is limited to either repair or replacement of parts, subject to the additional limitations below. This warranty neither assumes nor authorizes any person to assume obligations other than those expressly covered by this warranty. Travel beyond 50 miles round trip and more than 2 hours round trip.

**NO CONSEQUENTIAL DAMAGES. ENTRÉE L.L.C. IS NOT RESPONSIBLE FOR ECONOMIC LOSS; PROFIT LOSS; OR SPECIAL, INDIRECT, OR CONSEQUENTIAL DAMAGES, INCLUDING WITHOUT LIMITATION, LOSSES OR DAMAGES ARISING FROM FOOD OR PRODUCT SPOILAGE CLAIMS WHETHER OR NOT ON ACCOUNT OF REFRIGERATION FAILURE.**

**WARRANTY IS NOT TRANSFERABLE.** This warranty is not assignable and applies only in favor of the original purchaser/user to whom delivered. ANY SUCH ASSIGNMENT OR TRANSFER SHALL VOID THE WARRANTIES HEREIN MADE AND SHALL VOID ALL WARRANTIES, EXPRESS OR IMPLIED, INCLUDING ANY WARRANTY OF MERCHANTABILITY OR FITNESS FOR A PARTICULAR PURPOSE.

**IMPROPER USAGE.** ENTRÉE L.L.C. ASSUMES NO LIABILITY FOR PARTS OR LABOR COVERAGE FOR COMPONENT FAILURE OR OTHER DAMAGES RESULTING FROM IMPROPER USAGE OR INSTALLATION OR FAILURE TO CLEAN AND/OR MAINTAIN PRODUCT AS SET FORTH IN THE OWNER'S MANUAL PROVIDED WITH THE UNIT.

**RELOCATION OF CABINET FOR REPAIR:** Entrée L.L.C. is not responsible for the cost to move a cabinet for any reason from its position of operation on the customer's premises to make a warranty repair.



## STANDARD TWO-YEAR WARRANTY

**(TWO-YEAR PARTS & LABOR WARRANTY For products produced after serial number 1301ENTH00001.)**

RESIDENTIAL APPLICATIONS: Entrée L.L.C. assumes no liability for parts or labor coverage for component failure or other damages resulting from installation in non-commercial or residential applications.

ALTERATION, NEGLIGENCE, ABUSE, MISUSE, ACCIDENT, DAMAGE DURING TRANSIT OR INSTALLATION, FIRE, FLOOD, ACTS OF GOD. Entrée L.L.C. is

not responsible for the repair or replacement of any parts that Entrée L.L.C. determines have been subjected after the date of manufacture to alteration, neglect, abuse, misuse, accident, damage during transit or installation, fire, flood, or act of God.

IMPROPER ELECTRICAL CONNECTIONS. ENTRÉE L.L.C. IS NOT RESPONSIBLE FOR THE REPAIR OR REPLACEMENT OF FAILED OR DAMAGED COMPONENTS RESULTING FROM INCORRECT SUPPLY VOLTAGE, THE USE OF EXTENSION CORDS, LOW VOLTAGE, OR UNSTABLE SUPPLY VOLTAGE. THE USE OF PIERCING VALVES IS PROHIBITED AND IF LEFT IN THE SYSTEM VOIDS ALL WARRANTIES. THIS EQUIPMENT IS INTENDED FOR INDOOR USE ONLY.

NO IMPLIED WARRANTY OF MERCHANTABILITY OR FITNESS FOR A PARTICULAR PURPOSE: THERE ARE NO OTHER WARRANTIES, EXPRESSED, IMPLIED OR STATUTORY, EXCEPT THE TWO (2) YEAR PARTS & LABOR WARRANTY AND THE ADDITIONAL THREE (3) YEAR COMPRESSOR WARRANTY AS DESCRIBED ABOVE. THESE WARRANTIES ARE EXCLUSIVE AND IN LIEU OF ALL OTHER WARRANTIES, INCLUDING IMPLIED WARRANTY AND MERCHANTABILITY OR FITNESS FOR A PARTICULAR PURPOSE. THERE ARE NO WARRANTIES WHICH EXTEND BEYOND THE DESCRIPTION ON THE FACE HEREOF.

OUTSIDE U.S.: This warranty does not apply to, and Entrée L.L.C. is not responsible for, any warranty claims made on products sold or used outside the United States and Canada.



**ENTRÉE LLC**

**4673 OSBORNE DRIVE SUITE D**

**EL PASO, TX 79922**

**Warranty Service- Technical Support**

**(704) 900 2068**