

Owner's Manual

IC-B7S
IC-B7VH
IC-C7S
IC-C7VH

Snell

SPECIFICATIONS	IC-B7S	IC-B7VH
Frequency Response ($\pm 3\text{dB}$)	48 Hz-20 kHz	48 Hz-20 kHz
Recommended Amplifier	75-250W	75-250W
Nominal Impedance	6 ohms	4 ohms
Sensitivity (2.83v at 1m)	89dB SPL	89dB SPL
Tweeter	1" SEAS Excel Millenium	1" SEAS Excel Millenium
Midrange	Dual 4 $\frac{1}{2}$ -inch (114mm) SEAS Excel Magnesium	Dual 4 $\frac{1}{2}$ -inch (114mm) SEAS Excel Magnesium
Bass Driver	Dual 8-inch (203mm) Scanspeak polycone	Dual 8-inch (203mm) Scanspeak polycone
Crossover Points	300 Hz / 2.8kHz	300 Hz / 2.8kHz
Boundary Compensation	Yes	Yes
Grille	Black cloth over MDF frame	Black cloth over MDF frame
Dimensions (HxWxD)	21 x 16 $\frac{1}{2}$ x 11 inches (534 x 420 x 280mm) <i>depth includes $\frac{5}{8}$" (16mm) grille</i>	30 x 13 x 11 inches [†] (762 x 331 x 280mm) <i>depth includes $\frac{5}{8}$" (16mm) grille</i>
Finish*	Textured black paint	Textured black paint
Weight	60 lbs (27.3 kg) / each	63 lbs (28.6 kg) / each

* Custom paint and grilles are available for an extra charge

[†] 13 x 30 x 11 inches (331 x 762 x 280mm)
with horizontal orientation

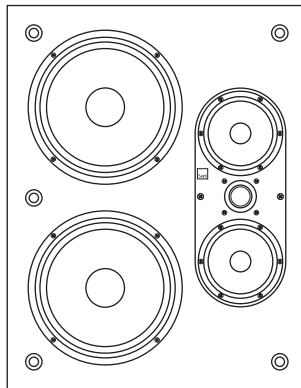

IC-B7S

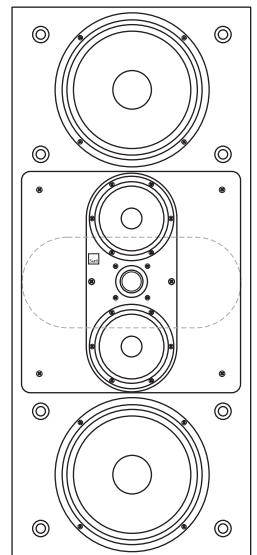

IC-B7VH

IC-C7S

48 Hz–20 kHz

75–250W

4 ohms

89dB SPL

1" SEAS silk dome

Dual 4¹/₂-inch (114mm)
SEAS treated paper

Dual 8-inch (203mm)
Scanspeak polycone

300 Hz / 2.8kHz

Yes

Black cloth over MDF frame

21 x 16¹/₂ x 11 inches
(534 x 420 x 280mm)
depth includes 5/8" (16mm) grille

Textured black paint

60 lbs (27.3 kg) / each

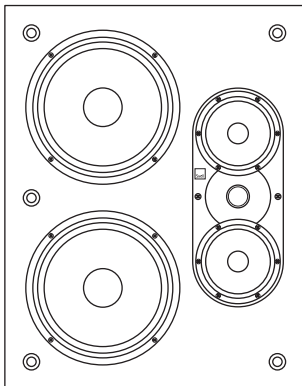

IC-C7S

IC-C7VH

48 Hz–20 kHz

75–250W

4 ohms

89dB SPL

1" SEAS silk dome

Dual 4¹/₂-inch (114mm)
SEAS treated paper

Dual 8-inch (203mm)
Scanspeak polycone

300 Hz / 2.8kHz

Yes

Black cloth over MDF frame

30 x 13 x 11 inches[†]
(762 x 331 x 280mm)
depth includes 5/8" (16mm) grille

Textured black paint

63 lbs (28.6 kg) / each

[†] 13 x 30 x 11 inches (331 x 762 x 280mm)
with horizontal orientation

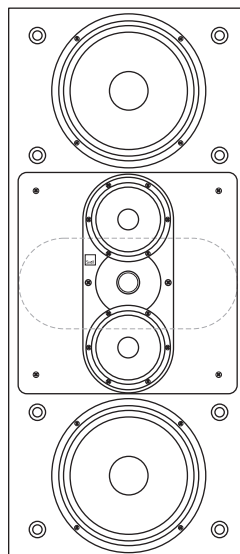

IC-C7VH

INTRODUCTION: HIGH END PERFORMANCE IN A PLAIN WRAPPER

The concept behind the Snell IC (In-Cabinet) series models is simple — loudspeakers that deliver performance equivalent to the acclaimed, elegantly-finished Series 7 in-room models, that are housed in cabinets with a “utility” finish, and are mechanically and acoustically designed for easy integration into built-in installations.

These simply finished models are in no way acoustically or mechanically inferior to the in-room Snell speakers. They use the same high-quality parts as their in-room counterparts — high excursion woofers, wide dispersion tweeters, low resonance cabinets and audiophile grade crossovers components. This ensures that the sound they produce is as powerful, yet clean and effortless, as the in-room speakers from which they are derived.

In addition, the IC Series models incorporate design elements that anticipate the unpredictable acoustical characteristics of custom installations. In some custom installations, for example, the location of the bass drivers can cause their sound to interact with the physical surroundings and produce a mid-bass response error. This results in a “heavy” or “chesty” quality that is particularly noticeable in voices. The Snell IC models have Boundary Compensation switches to help control this problem.

Design elements such as this, and many others, ensure that the IC Series models provide the discerning listener with the same engaging experience as that provided by a traditional loudspeaker.

PLACEMENT OF THE FRONT CHANNEL SPEAKERS

A home theatre system includes three loudspeakers placed across the front of the listening room. The distance between the left and right speakers determines the width of the stereo image. If the speakers are placed too close together, the image will be too narrow; too far apart and the blend will suffer, creating a hole in the middle. When properly placed, your speakers will create a continuous "virtual image" from left to right, with an illusion of sound outside, in front of, and behind the speaker systems.

We recommend an angular separation between 45 degrees and 60 degrees (when viewed from above). At the minimum 45° separation the distance between the speakers is 75% of the distance from the speakers to the listener. At the maximum 60° separation the distance between the speakers is equal to the distance from the speakers to the listener.

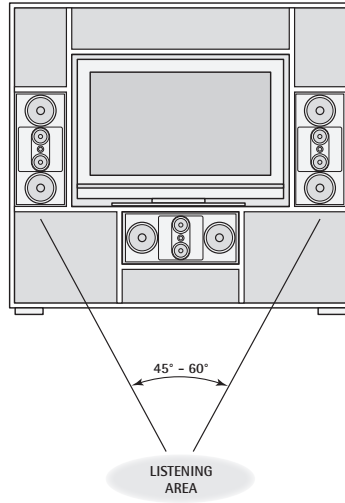

Creating a seamless sound image across the front of the speakers requires careful placement. The distance from the left, right, and center channel speakers to the listener location should be as close to equal as possible.

The front channel speakers should be installed so the height of the midrange/tweeter module is as close as possible to the height of a seated listener's ears. Try to keep the front channel tweeters within two vertical feet of that height.

TIP: Our ears use high frequencies to locate the source of a sound. When the IC-B7S or IC-C7S are used for the front left and right speakers in a system, the orientation of the midrange/tweeter array significantly effects the width of the stereo image. Changing the orientation of the speakers changes the separation of the midrange/tweeter module by 18 inches. Use this if necessary to get the ideal separation and stereo image.

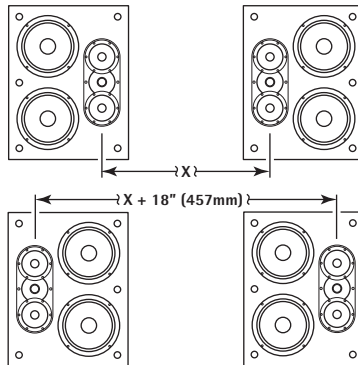

PLACEMENT OF THE SURROUND SPEAKERS

There are many opinions about where surround speakers should be mounted. The following is based on the findings of the best academics, and on our experience with many installations. These placement recommendations apply to all the IC models. The illustration below shows the speakers custom-installed in recesses in the wall. Alternatively the equivalent in-wall models could be used. Note: The choice of models used in the illustration is arbitrary. Any of the models covered in this manual may be used in any of the surround locations. However, the midrange/tweeter array in the IC-B7VH / IC-C7VH must always be vertically oriented.

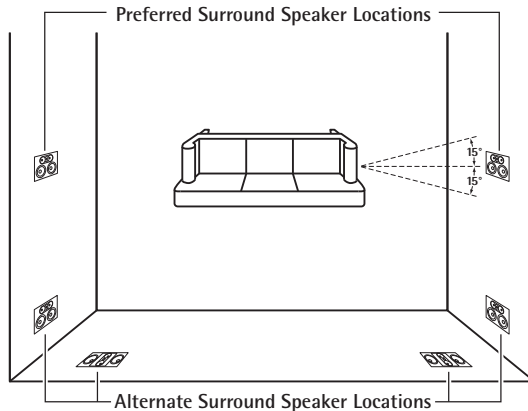

If two surrounds are used in a standard 5.1 configuration (not 7.1 or EX), they are best mounted directly to the sides of the primary seating location, preferably within $\pm 15^\circ$. (See the illustration.) This is preferred over back wall mounting for several reasons: It places the surround speakers where our ear's ability to discriminate left from right is at its best. This gives the maximum sense of "envelopment" or being surrounded by sound. Furthermore, mounting the rear speakers behind the listener increases the angle between the front and rear speakers. This reduces the likelihood that there will be a continuous front-to-rear sound image. Finally, our ear's ability to discriminate the front-to-rear location of a sound source is not very strong. Locating surround speaker to the side of the listener helps in this regard. 7.1 or EX systems that use side and rear speakers together overcome all of these obstacles and give both maximum envelopment and a more continuous surround effect.

A second factor to consider is the evenness of sound coverage over the seating area. Most surround processors have features for setting the balance of all channels. A circulating noise signal is adjusted in each channel until the apparent or measured sound level is even. Of course, moving to another seat will shift this balance somewhat. Well-placed surround speakers will minimize the level variation from seat to seat. The best way to improve evenness is to increase the distance of the surround speakers from the listening area. Mount them high on the side walls or even in the ceiling. Surround speakers should be at least one foot above the height of a standing listener. If the speakers are ceiling-mounted, they should be close to the side walls, well away from an overhead position.

If a large theater room with three or more rows of seats is planned, then more than one pair of surround speakers should be used to give more even coverage and a more diffuse sound field. We recommend that a pair of surrounds be used for every other seating row (the first, the third, the fifth, etc.). This follows standard cinema practice.

BASIC SPEAKER CONNECTION

Plan the wiring paths from the speakers to the amplifier. We recommend 16-gauge wire for runs up to 25 feet, and 14-gauge wire for longer runs. Be sure the speaker wire does not rest or rub against any sharp or pointed objects. Allow an extra foot of wire at the speaker location to make it easier to connect the speaker before setting it in position .

For normal, single wire connection, unscrew (turn counter-clockwise) one set of the terminal knobs. Strip about 1/2" (12mm) of the insulation from the two wire conductors and twist the wire strands into a tight bundle. Insert the wire into the hole in the terminal shaft and turn the terminal knob clockwise to clamp the wire in place. Be sure there are no loose strands of wire that could touch the other terminal.

Be sure the positive and negative speaker terminals of the amplifier are connected to the corresponding + (red) and - (black) terminals of the speakers. All wire is marked in some way to make it easy to trace the connections. The two conductors will be color coded, or there will be a stripe or ridge on the insulation, to identify them.

The terminals also accept wires with pin lugs or spade lugs attached. Dual banana plugs can also be plugged into the back of the terminals.

When connecting more than two speakers per amplifier channel, you should use series/parallel wiring. In all cases, make certain that the total impedance does not fall below the amplifier's rating. If you are not sure, contact your Snell Acoustics dealer.

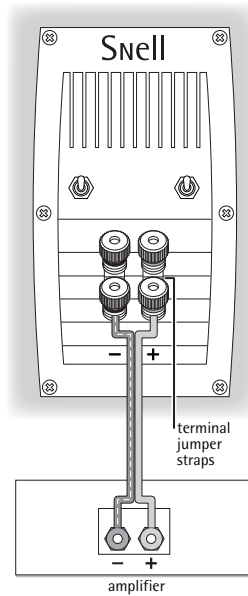

BI-WIRING

High performance audio systems can benefit from bi-wiring the speakers. This involves connecting two sets of wires between the amplifier and the speakers. If you are bi-wiring your speakers removed the terminal straps by loosening the terminal knobs and sliding the straps to the side.

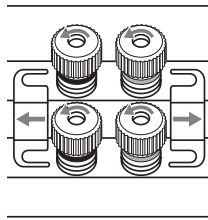

Use equal lengths of the appropriate wire to bi-wiring the speakers. Consult your dealer for cable options. Connect the wires between the amplifier and speakers as illustrated.

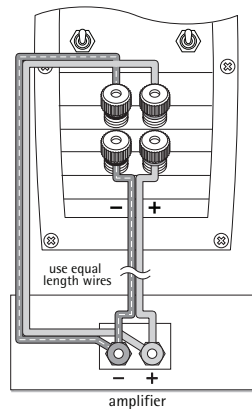

BI-AMPLIFYING

To achieve the highest level of performance, the speakers can be bi-amplified. In this type of system two separate amplifiers are used to drive the speakers. One amplifier drives the midrange/tweeter array, while a second drives the bass speakers. As with bi-wiring, the jumper straps must be removed from the connection terminals. Then connect the speakers as show in the illustration

NOTE: Do not employ an external crossover of any sort, whether passive or active. Doing so will interfere with the phase and frequency response of the speakers. The internal crossover circuitry is an integral part of the speakers and necessary to the proper response and function of its D'Appolito array and overall performance.

NOTE: It is imperative that the amplifiers used to bi-amplify the speakers are identical.

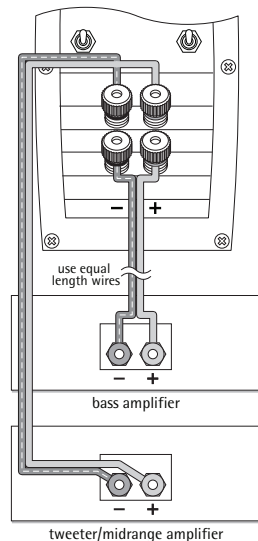

CONTROL SETTINGS

There are two switches on the connection terminal cup that enable you to make slight adjustments to the response of the speakers. They can be used to help you get the best possible performance from your speakers in a variety of installation situations.

The Boundary Switch

In some situations it may be necessary to install the speakers where they may not produce the best overall sound balance. One example is when, in order get the best sound image, the speakers must be installed close to a corner, or any large object that forms a corner such as a fireplace or a large column. This can cause uneven response in the upper bass and lower midrange which produces sound that can be described as "thick" or "heavy". This is particularly noticeable in vocal reproduction. The Boundary switch located above the connection terminals can help control this.

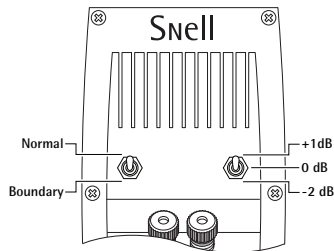

If the speakers are located less than 12"-18" (30-45cm) from a corner or other large object, try setting the switch to the Boundary position. Use source material that has a strong vocal component to see if this setting produces smoother, more natural sound.

Tweeter Level Switch

The IC-B and IC-C series speakers have a three-position switch to adjust the output level of the tweeter. In most rooms, the middle "0dB" position will produce the best sound. In rooms that have plush carpeting and heavily upholstered furniture try the switch in the "+1dB" position. In rooms that have more hard reflective surfaces, try the "-2dB" position.

LISTENING LEVELS AND POWER HANDLING

The power recommendation for the system assumes you will operate the amplifier in a way that will not produce distortion. All speakers can be damaged by even a modest amplifier if it is producing distortion. If you hear a gritty noise or other signs of strain, turn down the volume. Prolonged or repeated operation of your speakers with a distorted signal can cause damage that is not covered by the warranty. It is especially important that you do not overdrive the bass capability of smaller speakers. Watch for noises, such as pops, caused by the music's bass line. Use of the loudness control and/or full bass boost at louder volumes is likely to overdrive the woofer. Use such controls sparingly.

HOW TO CARE FOR YOUR SPEAKERS

- ▶ Use a soft terry cloth towel slightly dampened with water, glass cleaner, or a diluted mild detergent. The towel should be just damp enough to wipe the surface clean without leaving a trail of moisture.
- ▶ Do not use abrasive cleaners or any cleaner containing chemicals harsher than those found in glass cleaner.

LIMITED WARRANTY

For five years from the date of purchase, Snell Acoustics will repair for the original owner any defect in materials or workmanship that occurs in normal use of the speaker system, without charge for parts and labor.

Your responsibilities are to use the product according to the instructions supplied, to provide safe and secure transportation to an authorized Snell Acoustics service representative, and to present proof of purchase from an authorized Snell dealer in the form of your sales slip when requesting service.

Excluded from this warranty is damage that results from abuse, misuse, accidents, shipping, repairs, or modifications by anyone other than an authorized Snell Acoustics service representative. This warranty is void if the serial number has been removed or defaced.

This warranty gives you specific legal rights, and you may also have other rights that vary from state to state.

If Service Seems Necessary

Contact the dealer from whom you purchased the speaker system. If that is not possible, call us at 607-352-2488,

or write to:

Snell Acoustics
2 Chambers Street
Binghamton, NY 13903 USA

We will promptly advise you of what action to take. If it is necessary to return your speaker system to the factory, please ship it prepaid in the original factory packaging. Please note that Snell Acoustics will not be held liable for shipping damage due to improper packaging. After it has been repaired, we will return it freight prepaid in the U.S. or Canada.



For EU Customers Only

This symbol found on the product indicates that the product must not be disposed of with household waste. Instead, it may be placed in a separate collection facility for electronic waste or returned to a retailer when purchasing similar product. The producer paid to recycle this product. Doing this contributes to reuse and recycling, minimizes adverse effects on the environment and human health and avoids any fines for incorrect disposal.

©2010 Snell Acoustics. All Rights Reserved.
Specifications are subject to change without notice.
Covered by patents issued and/or pending.
Part #542-1046

Snell

2 Chambers Street
Binghamton, NY 13903 USA
phone: 607-352-2488
fax: 607-352-2498
email: info@snellacoustics.com
web: www.snellacoustics.com