



## DYNAMIC FIRE DAMPER



**MODELS:**  
**75B-DY (1-1/2 HR rating)**

### APPLICATION

The model 75B-DY is constructed with standard construction-galvanized steel. 75B-DY is 1-1/2 hour UL rated dynamic damper for use in HVAC systems that remain in operation during a fire. The unit can be installed vertically in walls or horizontally in floors.

### RATING:

#### UL CLASSIFIED:

UL 555 Fire Resistance Rating  
Fire resistance rated 1-1/2 Hours  
Building materials rated in 2 hours fire partition

### Standard Construction

- Frame: 22 ga. Galvanized Steel
- Blade: 22 ga. Galvanized Steel
- Closure Spring: Stainless Steel
- Fusible Link: 165°F
- Mounting: Horizontal or Vertical

Dynamic Fire Dampers:  
Bi-directional  
2000 FPM maximum velocity  
4.0 WG maximum static pressure

Feature horizontal closure spring operation under airflow in HVAC systems where fans remain running in Fire and smoke control dynamic fire dampers bear a label Attesting to airflow and maximum static pressure limits.

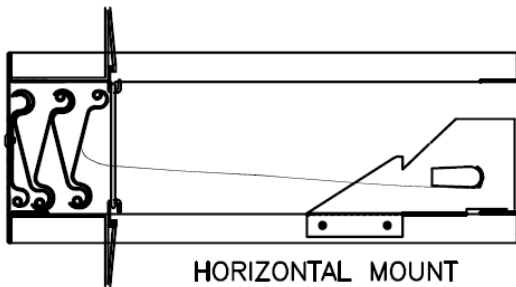
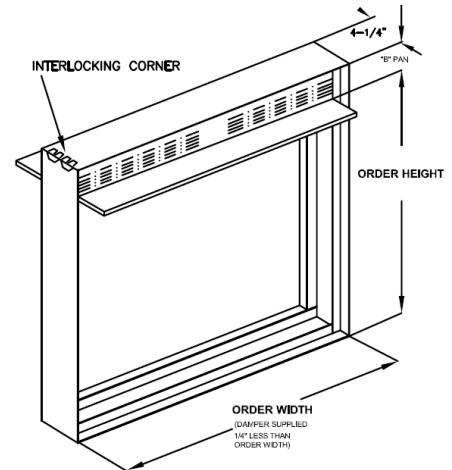

HORIZONTAL MOUNT

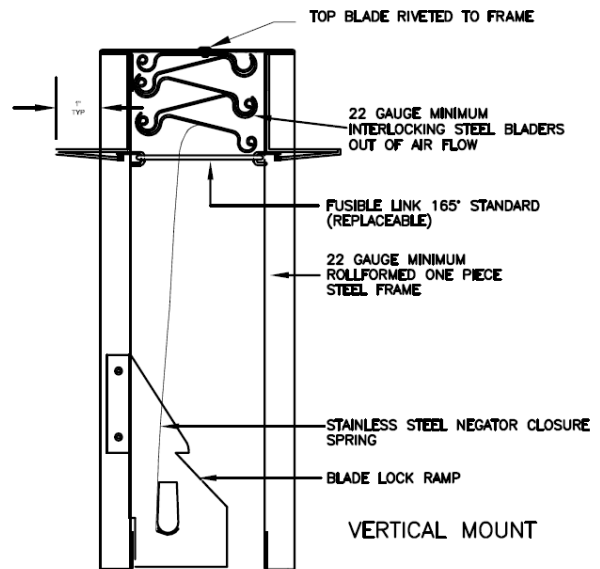

VERTICAL MOUNT

|            | Single Section     |                    | Multiple Section                 |
|------------|--------------------|--------------------|----------------------------------|
|            | Minimum Size (WxH) | Maximum Size (WxH) | Maximum Size (WxH)               |
| Vertical   | 4"x4"              | 24"x24"            | Consult factory for availability |
| Horizontal | 4"x4"              | 24"x24"            | Consult factory for availability |

231 Commerce Dr. Montgomeryville, PA 18936  
Tel: 215-412-4445 Fax: 215-412-4409  
Email: lloydind@firedamper.com

138 Industrial Loop West, Orange Park, FL 32073  
Tel: 904-541-1655 Fax: 904-541-1657  
Email: lloydind1@bellsouth.net

B1, 4/F., Luen Ming Hing Factory Building  
36 Mok Cheong St.,  
To Kwa Wan, Kowloon, H. K.  
Tel: 852-2760-4188 Fax: 852-2760-4177  
Email: tatanlexyim@lloydasia.com





## SLEEVES MODEL 75 CURTAIN FIRE DAMPERS

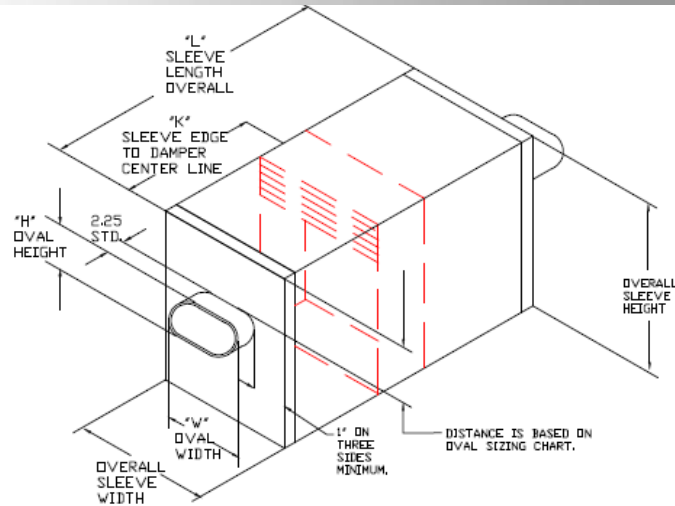

**MODEL:**  
75C RECTANGLE  
75CR ROUND  
75CO OVAL

**Type "CO"  
Oval Sleeve**

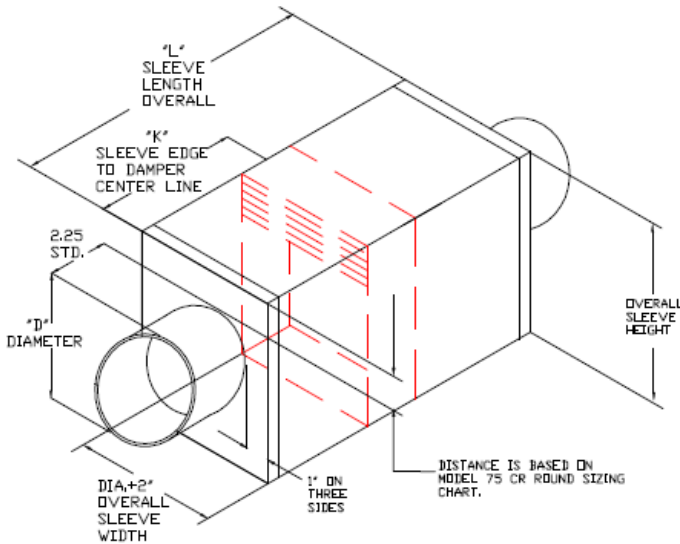

**Type "CR"  
Round Sleeve**

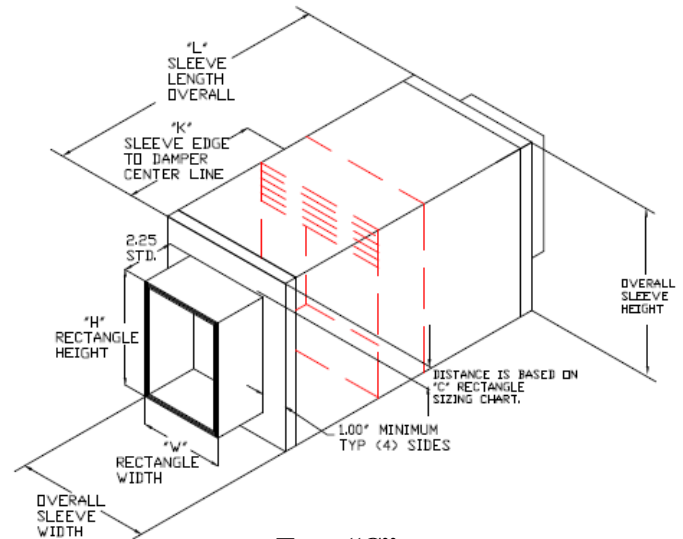

**Type "C"  
Rectangle Sleeve**

\* When ordering specify:

Rectangle x Width x Height x Length x Gauge + "K" dimension

When not specified, dampers will be provided centered in sleeve length. (L/2)

### SLEEVE DIMENSIONAL INFORMATION FOR CURTAIN FIRE DAMPERS AND DOORS

- Dampers and sleeves are always priced and ordered by W x H or dimensions as shown above. The type C, CR, and CO require the damper to be oversized. Actual overall dimensions can be determined by adding sleeve material thickness to the basic damper dimensions (after allowing for the standard 1/4" damper under sizing).
- "K" distance may be ordered at any dimension up to the sleeve length less one half the damper frame width. If "K" dimension is not specified, "K" dimension will be provided as sleeve length, L/2 (damper on centerline).



## DAMPER INSTALLATION INSTRUCTIONS

### Installation and Maintenance Instructions 1-1/2 Hour Rated, UL Classified model 75 fire dampers For use in fire barriers with ratings of less than 3 hours

#### INSPECTION

1. Inspect for shipping damage.
2. Inspect for proper size and model.
3. Inspect installed damper for proper orientation, as stated on damper label.
4. Inspect for obstructions and complete closure.
5. Manually cycle the damper to verify proper operation.

#### Typical Wall Installation

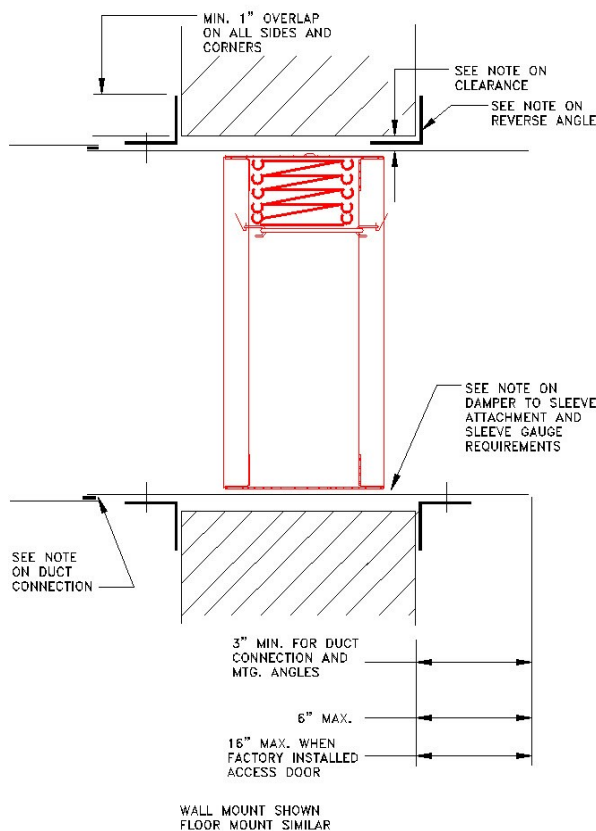

#### INSTALLATION

The basic intent of a proper installation is to secure the fire damper in, not to, the opening in such a manner as to prevent distortion and disruption of damper operation by allowing the fire damper in openings to expand and the connecting duct to separate in the event of the collapse of the hanging system. The fire damper must be positioned within the masonry, block or gypsum wallboard fire barrier. Reference our details of a suggested drywall partition.

#### DAMPER TO SLEEVE ATTACHMENT

A Sleeve shall be of sufficient length to permit direct attachment of perimeter mounting angles. This damper can be supplied by the factory mounted in a sleeve. If the sleeve is not factory supplied, it must be attached on both sides of the damper by one of the following methods:  
Secure with 1/4" dia. Bolts and nuts or by welding with beads 1/2" in length, or with No.10 steel sheet metal screws, or 3/16" steel rivets. Fasteners shall be 8" maximum on centers, fasteners cannot be placed where they will interfere with damper operation. Gaps at corners between the damper and its sleeve must be small enough to prohibit the passage of an 1/8" diameter rod through the entire depth of the gap between two damper panels and its sleeve.

#### SLEEVE THICKNESS

Sleeves shall be the same gauge or heavier as the duct to which it is attached. Gauges shall conform to SMACNA or ASHRAE duct standards. Damper sleeve can be no thicker than 10GA steel. On type C dampers, the sleeve must be 18GA or heavier.

#### EXPANSION CLEARANCE

The opening in the wall or floor for the fire damper shall be sized so as to provide expansion clearance between the sleeve and opening. Clearances do not vary with walls constructed of different materials. A minimum of 1/8" per foot of overall damper/sleeve width and height is required. The maximum opening size shall not 1/8" per foot plus 1", minimum total clearance shall be at least 1/4" larger than the overall assembly.



INSTALLATION INSTRUCTIONS  
IN CONFORMANCE TO  
UNDERWRITERS LABORATORIES  
REQUIREMENTS





## DAMPER INSTALLATION INSTRUCTIONS

### Installation and Maintenance Instructions 3 Hours Rated, UL Classified model 75 fire dampers For use in fire barriers with ratings of less than 4 hours

#### INSPECTION

1. Inspect for shipping damage.
2. Inspect for proper size and model.
3. Inspect installed damper for proper orientation, as stated on damper label.
4. Inspect for obstructions and complete closure.
5. Manually cycle the damper to verify proper operation.

#### Typical Wall Installation

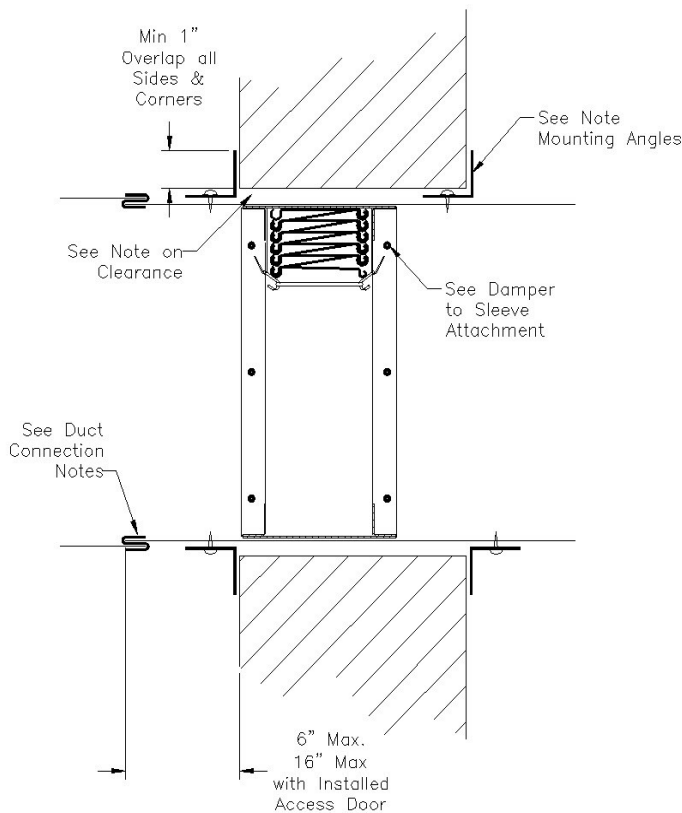

Wall Mount Shown (Vertical Installation)



INSTALLATION INSTRUCTIONS  
IN CONFORMANCE TO  
UNDERWRITERS LABORATORS  
REQUIREMENTS

#### INSTALLATION

The basic intent of a proper installation is to secure the fire damper in, not to, the opening in such a manner as to prevent distortion and disruption of damper operation by allowing the fire damper in openings to expand and the connecting duct to separate in the event of the collapse of the hanging system. The fire damper must be positioned within the masonry, block or gypsum wallboard fire barrier. Reference our details of a suggested drywall partition.

#### DAMPER TO SLEEVE ATTACHMENT

A Sleeve shall be of sufficient length to permit direct attachment of perimeter mounting angles. This damper can be supplied by the factory mounted in a sleeve. If the sleeve is not factory supplied, it must be attached on both sides of the damper by one of the following methods: Secure with 1/4" dia. Bolts and nuts or by welding with beads 1/2" in length, or with No.10 steel sheet metal screws, or 3/16" steel rivets. Fasteners shall be 8" maximum on centers, Fasteners cannot be placed where they will interfere with damper operation. Gaps at corners between the damper and its sleeve must be small enough to prohibit the passage of an 1/8" diameter rod through the entire depth of the gap between two damper panels and its sleeve.

#### SLEEVE THICKNESS

Sleeves shall be the same gauge or heavier as the duct to which it is attached. Gauges shall conform to SMACNA or ASHRAE duct standards. Damper sleeve can be no thicker than 10GA steel. On type C dampers, the sleeve must be 18GA or heavier.

#### EXPANSION CLEARANCE

The opening in the wall or floor for the fire damper shall be sized so as to provide expansion clearance between the sleeve and opening. Clearances do not vary with walls constructed of different materials. A minimum of 1/8" per foot of overall damper/sleeve width and height is required. The maximum opening size shall not 1/8" per foot plus 1", minimum total clearance shall be at least 1/4" larger than the overall assembly.





## DAMPER INSTALLATION INSTRUCTIONS

### Installation and Maintenance Instructions 3 Hours Rated, UL Classified model 75 fire dampers For use in fire barriers with ratings of less than 4 hours

#### INSPECTION

1. Inspect for shipping damage.
2. Inspect for proper size and model.
3. Inspect installed damper for proper orientation, as stated on damper label.
4. Inspect for obstructions and complete closure.
5. Manually cycle the damper to verify proper operation.

#### INSTALLATION

The basic intent of a proper installation is to secure the fire damper in, not to, the opening in such a manner as to prevent distortion and disruption of damper operation by allowing the fire damper in openings to expand and the connecting duct to separate in the event of the collapse of the hanging system. The fire damper must be positioned within the masonry, block or gypsum wallboard fire barrier. Reference our details of a suggested drywall partition.

#### DAMPER TO SLEEVE ATTACHMENT

A Sleeve shall be of sufficient length to permit direct attachment of perimeter mounting angles. This damper can be supplied by the factory mounted in a sleeve. If the sleeve is not factory supplied, it must be attached on both sides of the damper by one of the following methods:

Secure with 1/4" dia. Bolts and nuts or by welding with beads 1/2" in length, or with No.10 steel sheet metal screws, or 3/16" steel rivets. Fasteners shall be 8" maximum on centers, Fasteners cannot be placed where they will interfere with damper operation. Gaps at corners between the damper and its sleeve must be small enough to prohibit the passage of an 1/8" diameter rod through the entire depth of the gap between two damper panels and its sleeve.

#### SLEEVE THICKNESS

Sleeves shall be the same gauge or heavier as the duct to which it is attached. Gauges shall conform to SMACNA or ASHRAE duct standards. Damper sleeve can be no thicker than 10GA steel. On type C dampers, the sleeve must be 18GA or heavier.

#### EXPANSION CLEARANCE

The opening in the wall or floor for the fire damper shall be sized so as to provide expansion clearance between the sleeve and opening. Clearances do not vary with walls constructed of different materials. A minimum of 1/8" per foot of overall damper/sleeve width and height is required. The maximum opening size shall not 1/8" per foot plus 1", minimum total clearance shall be at least 1/4" larger than the overall assembly.

Typical Wall Installation

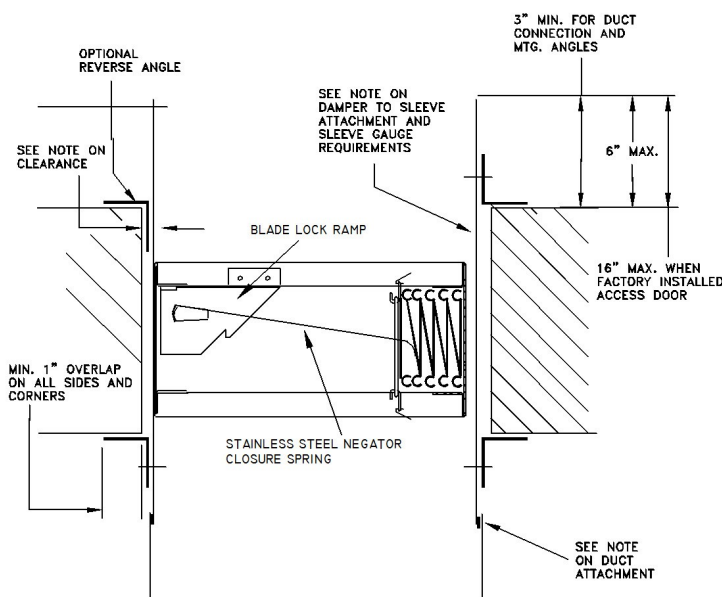

Horizontal mount shown



INSTALLATION INSTRUCTIONS  
IN CONFORMANCE TO  
UNDERWRITERS LABORATORIES  
REQUIREMENTS





## DAMPER INSTALLATION INSTRUCTIONS

### Installation and Maintenance Instructions 1-1/2 Hours Rated, UL Classified model 75 fire dampers For use in fire barriers with ratings of less than 3 hours

#### DAMPER BEHIND A GRILLE

1. Perimeter mounting angles to be a minimum of 1-1/2 x 1-1/2 x 16GA on dampers 36 x 50 and smaller. For dampers greater than 36 x 50, angles to be a minimum of 1-1/2 x 1-1/2 x 14GA.
2. Grille to flange fasteners cannot penetrate fire wall ( see note 4).
3. Secure angles to sleeve only, so as to frame the wall opening. Fasten to the sleeve only using the same means as required for fastening the damper to the sleeve.
4. Grille to flange attachment by means of 1/4" dia. Pop rivets, #8 sheet metal screws or #8 bolts and nuts. Fasteners to be plated steel or stainless steel, minimum two fasteners per side.

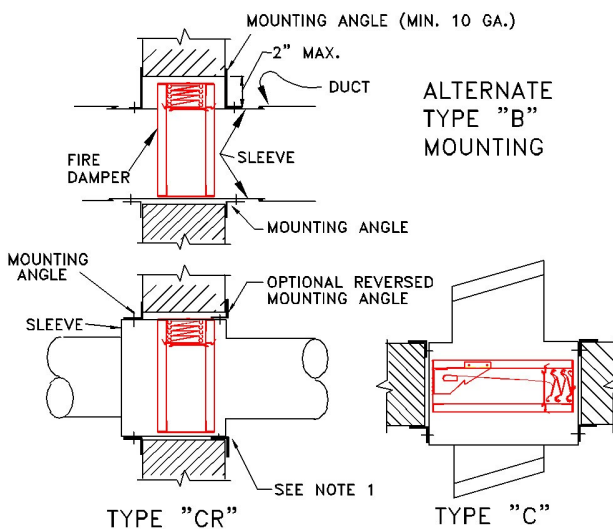
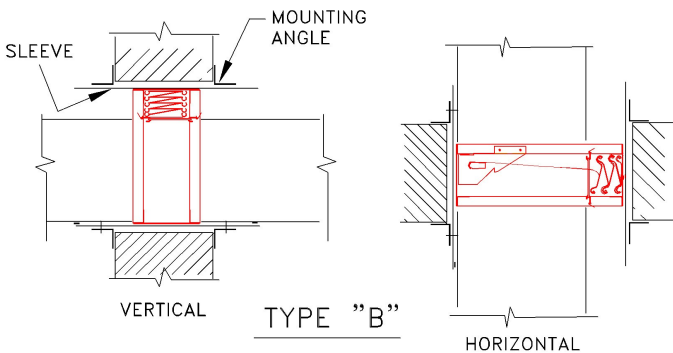

#### TYPE "CR"

The factory supplied 22 GA. Collar to 18 GA cap connection on type "C, CR" dampers is a breakaway connection under the following conditions:

1. Round unit duct diameters are no larger than 52"
2. Oval duct sizes are no larger than 58" W x 29"H.
3. Duct gauges shall conform to the SMACNA or ASHRAE duct standard.
4. Duct diameters of 22 inches(559mm) and smaller shall have 3 No. 10 (4.8mm) diameter sheet metal screws evenly spaced around the circumference of the duct.
5. Duct diameters greater than 22 inches and up shall have 5 sheet metal screws evenly spaced around the circumference of the duct.
6. Dampers outside of these restrictions (ie) multiple damper and special size and application dampers must use a 4" wide drawband connection as shown in the SMACNA Fire, Smoke, and Radiation Damper Installation Guide.

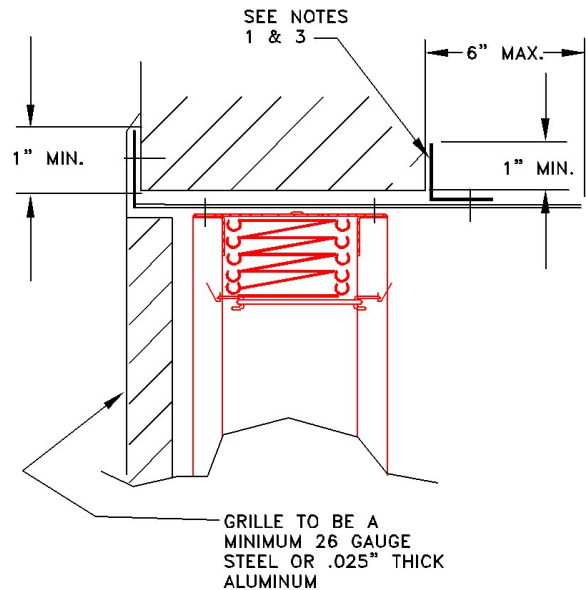

INSTALLATION INSTRUCTIONS  
IN CONFORMANCE TO  
UNDERWRITERS LABORATORIES  
REQUIREMENTS





## DAMPER INSTALLATION INSTRUCTIONS

### Installation and Maintenance Instructions 1-1/2 Hours Rated, UL Classified model 75 fire dampers For use in fire barriers with ratings of less than 3 hours

#### MOUNTING ANGLES

Secure mounting angles to the sleeve and not to the wall or floor. Mounting angles to frame the four sides of the sleeve on both faces.

When reverse mounting angles are used the size of the opening must be increased to maintain the specified expansion clearance between the angle/fasteners and the opening. Angles shall be a minimum of 1-1/2" x 1-1/2" x 16ga. On dampers 36 x 50 and smaller. For dampers greater than 36x50, angles to be a minimum of 1-1/2 x 1-1/2 x 14 ga. Fasten angles to the sleeve using 1/4" dia. Bolts and nuts or by welding with beads 1/2" in length, or with No. 10 steel sheet metal screws, or with 3/16" steel rivets. Fasteners or weld beads shall be 8" maximum on centers.

#### ACCESS

Suitable access must be provided for damper inspection and servicing. Where it is not possible to achieve sufficient size access, it will be necessary to install a removable section of duct.

#### DUCT CONNECTION

The installation of the damper and all duct connections to the damper sleeve shall conform to NFPA-90A and the SMACNA Fire, Smoke and Radiation Damper Installation Guide. All duct connection shall also conform to UL555. Connecting ducts shall not be continuous but shall terminate at the damper sleeve. Duct connections to the sleeve will be either of the breakaway or rigid types, breakaway types are listed below. The following determines if the connections are to be rigid or breakaway. For rigid type duct connections, sleeve shall be a minimum of 16 GA on dampers not exceeding 36" wide or 24" high or 24" diameter and 14ga on larger units. Dampers supplied with thinner sleeves will require a breakaway connection of the following type. Plain "S" slip, double "S" slip shown below.

Ductmate type-connections as shown on figure 6. All connections not listed as breakaway shall be considered as rigid. Breakaway joints of the types shown below shall have no more than two No.10 (4.8mm) diameter sheet metal screws on each side and on the top and bottom located in the center of the slip pocket and shall penetrate both sides of the slip pocket.

Breakaway joints of the type shown below are permitted on the top and bottom of horizontal ducts (vertical dampers) with flat slips not exceeding 20 inches (508mm) in length on the sides.

#### MAINTENANCE

Dampers shall be maintained in intervals as stated in NFPA-90A, Appendix B, unless local codes require more frequent inspections. Check the fuse link, check the stainless steel closure springs where furnished, cycle damper and check for free operation and complete closure, clean with mild detergent or solvent, secure damper open with fusible link.

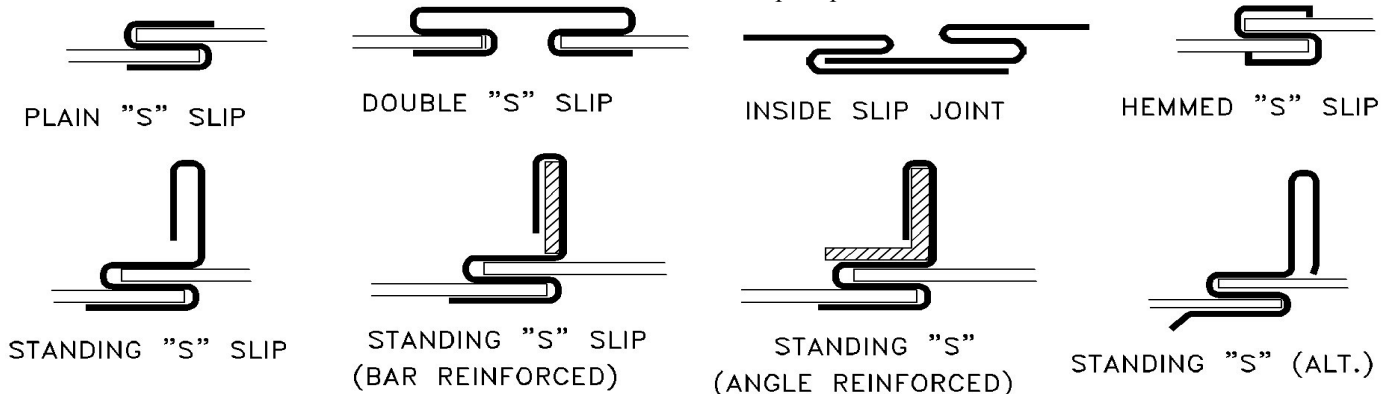

Figure 6



INSTALLATION INSTRUCTIONS  
IN CONFORMANCE TO  
UNDERWRITERS LABORATORIES  
REQUIREMENTS





## DAMPER INSTALLATION INSTRUCTIONS

### Installation and Maintenance Instructions 1-1/2 Hours Rated, UL Classified model 75 fire dampers For use in fire barriers with ratings of less than 3 hours

**NOTES:**

1. These illustrated partition designs have successfully been tested in conjunction with 1-1/2 hour classified fire dampers, for additional designs, reference Underwriters Laboratories, Inc. Fire Resistance Directory. Specific framing requirements of openings may vary with the local authority that has jurisdiction. Specific framing requirements should be provided in the architectural and structural drawing.
2. Reference the damper's installation instructions regarding the approved method of attaching the damper to the sleeve, attaching the retaining angles to the sleeve, required expansion clearances, sleeve gauge, ect. Type of framing does not effect the stated required expansion clearance.
3. Gypsum panels surrounding the opening are to be fastened to all stud and runner flanges, 12" O.C. maximum.
4. When wooden studs are used, filler pieces must be installed around the entire opening. Filler pieces are optional when metal studs are used ( consult local codes to determine if filler pieces are required). Filler pieces are to be double screwed (or nailed to wooden studs) on 12" max. centers to the web of runners and studs.
5. The office of the California State Fire Marshal and other local jurisdictions require filler pieces around both wood and metal framed openings (no filler pieces around concrete or masonry openings) These codes also require a double header for wood framed openings, consult local code authorities.
6. Double jamb studding shown and required when opening width or height exceeds 36". Single jamb studding acceptable for openings 36"x36" and smaller.

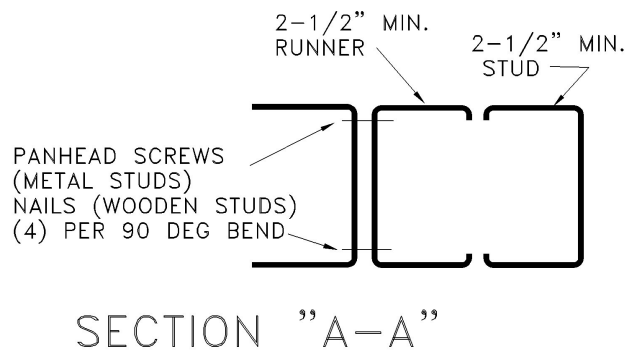
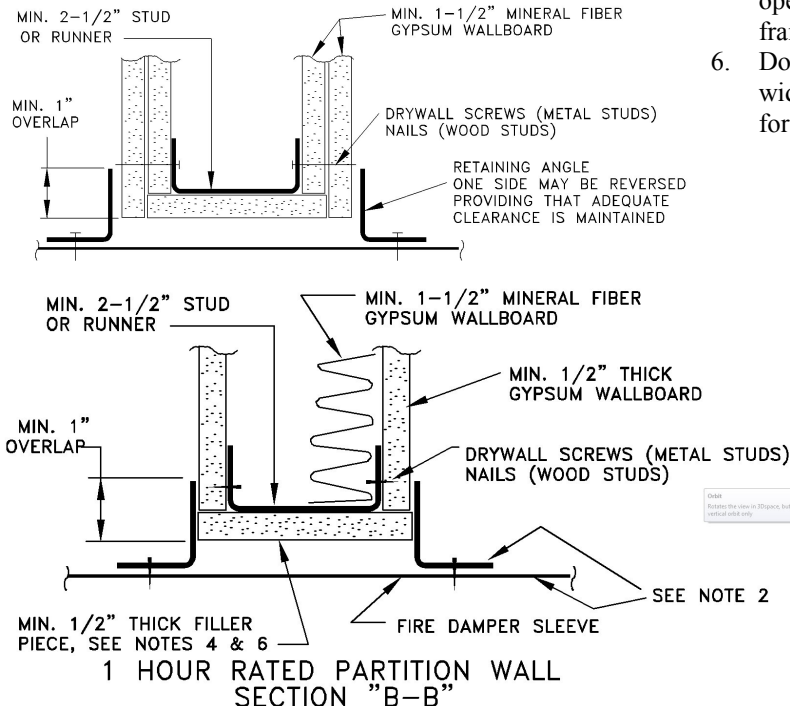
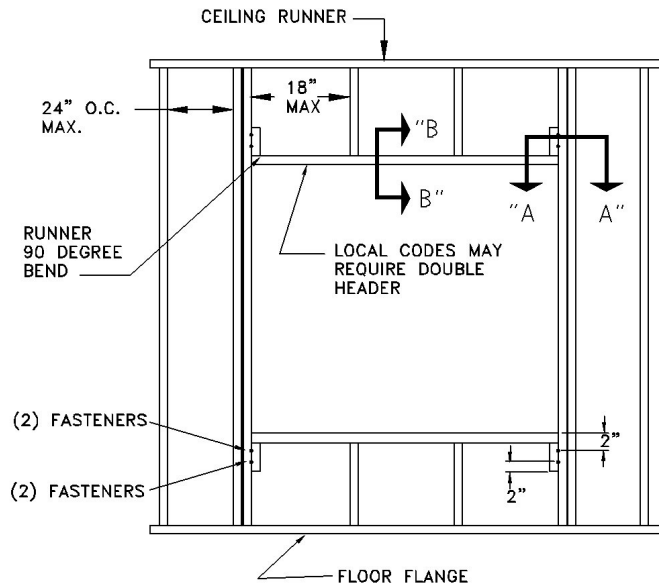

INSTALLATION INSTRUCTIONS  
IN CONFORMANCE TO  
UNDERWRITERS LABORATORIES  
REQUIREMENTS







## SLEEVE INSTALLATION INSTRUCTIONS

### BREAKAWAY CONNECTIONS

Transverse joints illustrated at right have always been approved as breakaway connections. SMACNA testing has also approved the following variations as breakaway connections.

Standing "S" joints can be applied with no. 10 sheet metal screws (through joint and duct) subject to the following limitations: Maximum 2 screws in each side and in bottom joint.

Transverse joints illustrated can be applied as top and bottom joints with Drive slip - side joints in duct heights up to 20 inches.

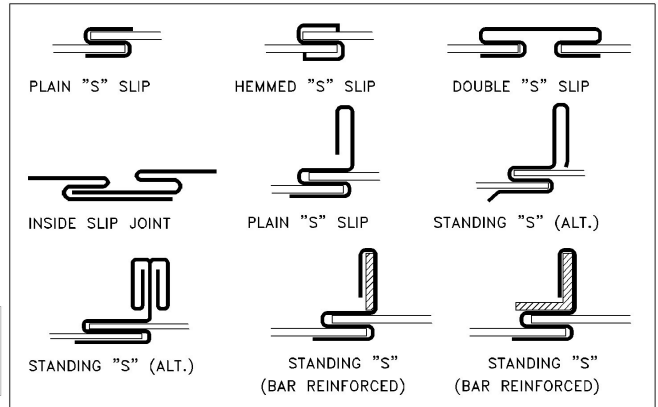

#### Round and Oval duct Breakaway Connections

Round or flat oval ducts connected to type R, CR or CO damper collars may use no.10 sheet metal screws as follows:  
Ducts to 22" wide (or dia.) and smaller may use 3 screws.  
Ducts larger than 22" wide (or dia.) may use 5 screws.

NOTE: All breakaway connections described may have duct sealant applied in accordance with SMACNA recommendations.

#### Manufactured Flanged System Breakaway Connections

Flanged connection systems manufactured by Ductmate, ward, and nexus are approved as breakaway connections when installed as

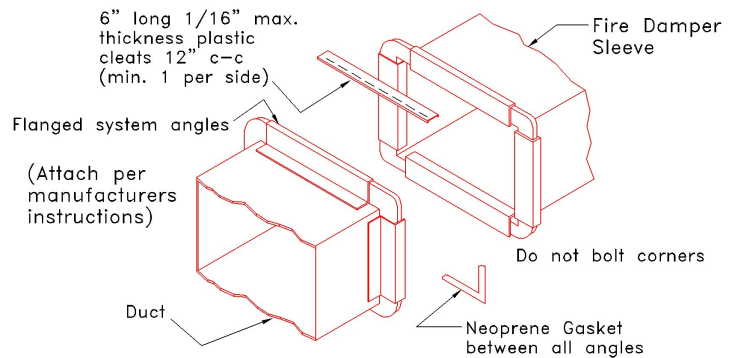

INSTALLATION INSTRUCTIONS  
IN CONFORMANCE TO  
UNDERWRITERS LABORATORIES  
REQUIREMENTS

#### Proprietary Flange System Breakaway Connections (TDC by Lockformer, TDF by Engle)

TDC and TDF systems are approved as breakaway connections when installed as described in the TDC or TDF addendum to the SMACNA Duct Construction Standards except the corners may not be bolted. Standard 6" metal clip may be used with spacing as shown in diagram.

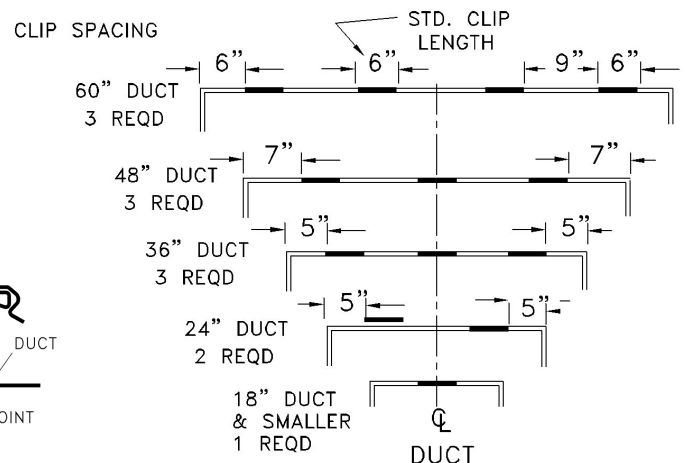
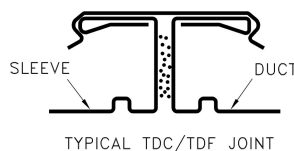



## DAMPER INSTALLATION INSTRUCTIONS

### MULLION INSTALLATION INSTRUCTIOS FOR FIRE DAMPERS INSTALLED OVERSIZED WALL OPENINGS

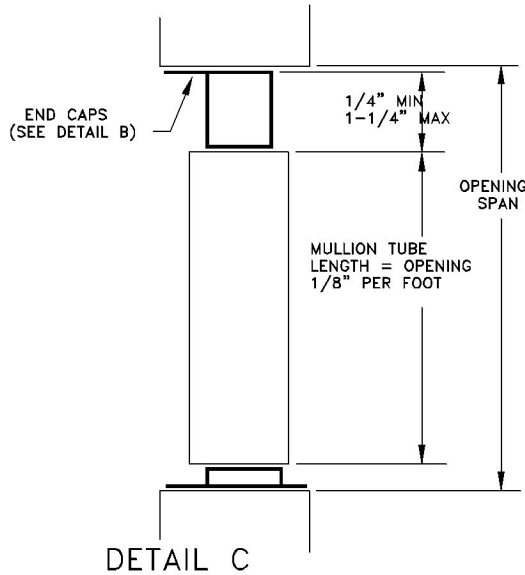

DETAIL C

The end caps are attached by means of 1" long x 3/8" dia. Steel expansion anchors embedded into the opening with 1/4" dia. Flat head machine screws, eight per end cap. If a steel lintel is used, four 1" long welds per end cap (two per leg) may be used.

used, four 1" long welds per end cap (two per leg) may be used.

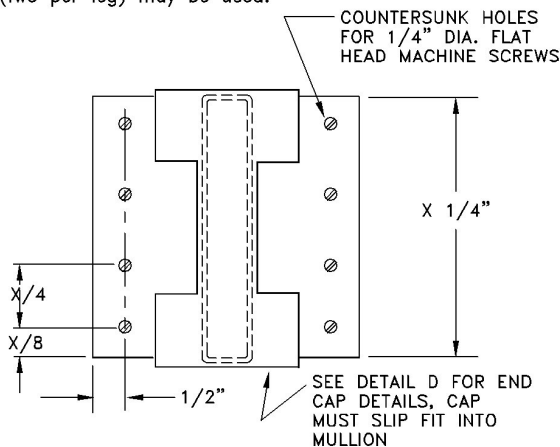

DETAIL E

END CAP INSERTED INTO MULLION

All horizontal and vertical mullion tubes must be terminated with an end cap. These end caps may not be fastened to the mullion tube and must slide freely inside the mullion tube.

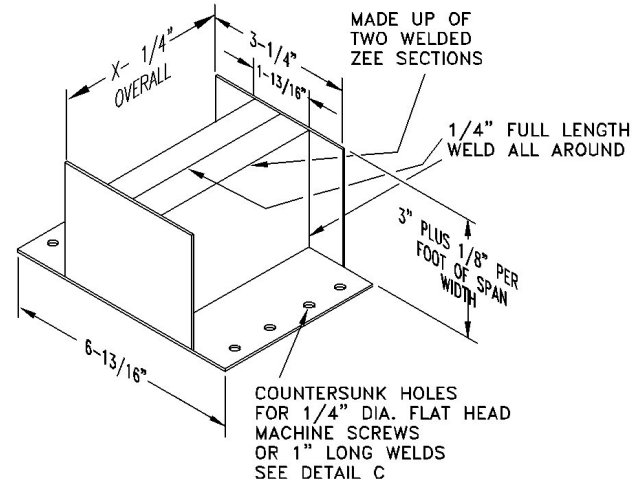

DETAIL D

Top, bottom or side end caps  
12 GA galvanized steel

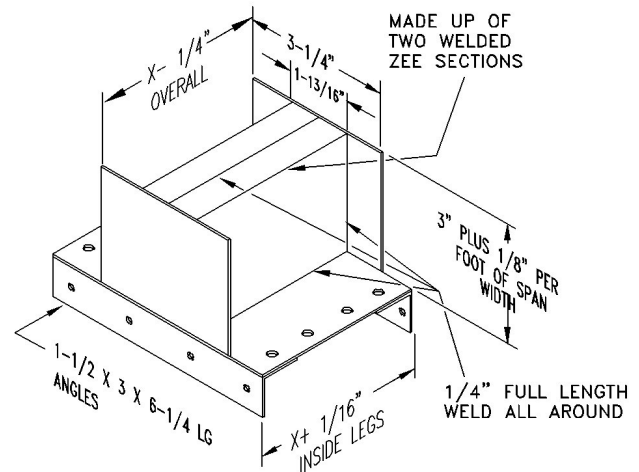

DETAIL F

Horizontal to vertical end cap 12 ga.  
galvanized steel

Attach the horizontal mullion end caps to the vertical mullion tube by means of (12) 3/16" dia. Blind rivets or by 1/8" full length weld.



INSTALLATION INSTRUCTIONS  
IN CONFORMANCE TO  
UNDERWRITERS LABORATORIES  
REQUIREMENTS





## DAMPER INSTALLATION INSTRUCTIONS

### MULLION INSTALLATION INSTRUCTIONS FOR FIRE DAMPERS INSTALLED OVERSIZED WALL OPENINGS

These fabricated galvanized steel mullions are intended to subdivide a large vertical wall opening into smaller openings. These smaller openings are not to exceed the maximum size restrictions of the UL Classified 1-1/2 hour galvanized steel fire damper assembly.

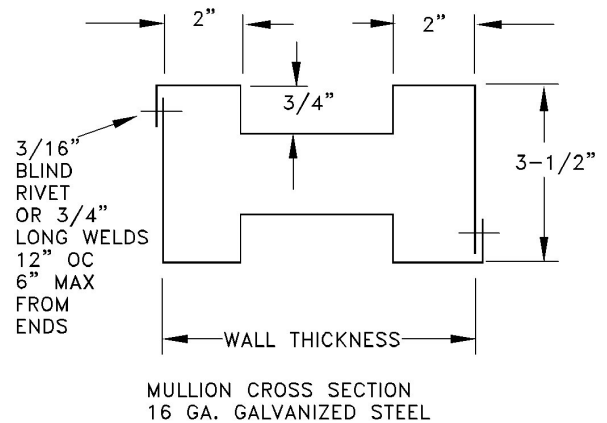
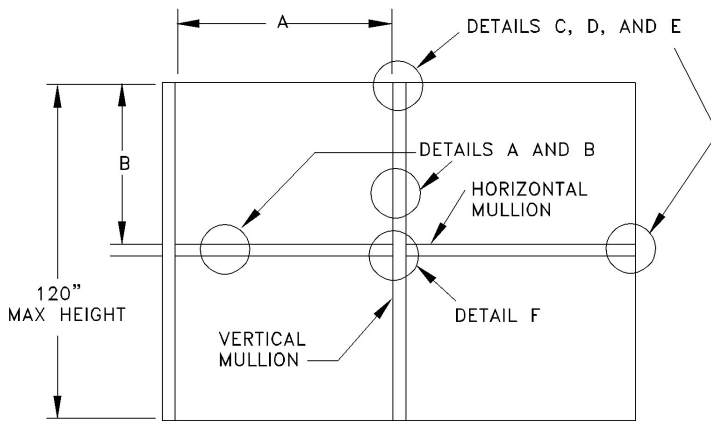

DETAIL A

“A” and “B” opening sizes are not to exceed the damper’s approved maximum multiple assembly size. Vertical, horizontal, or vertical and horizontal mullion can be used, depending on the opening size.

#### CONDITIONS & RESTRICTIONS

Fabricated from galvanized steel with a normal yield strength of 42,000 psi.

Intended for use in concrete block or poured walls only with a minimum wall thickness of 7” and a maximum wall thickness of 12”

To permit proper embedding of anchors, hollow concrete block walls are to be filled at the opening by minimum 3,500 psi concrete.

Steel mullions are not to be inside the ductwork. For ducted systems, each sub-divided opening must be individually ducted.

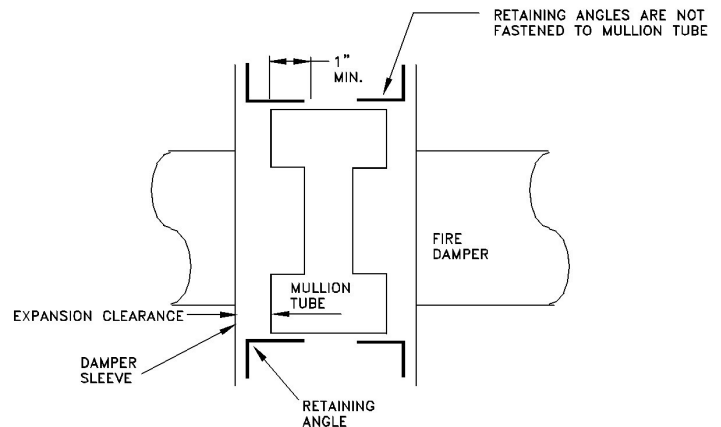

DETAIL B

Reference the damper’s installation instructions regarding the approved method of attaching the damper to the sleeve, attaching the retaining angles to the sleeve, required expansion clearances, sleeve gauge, ect.



INSTALLATION INSTRUCTIONS  
IN CONFORMANCE TO  
UNDERWRITERS LABORATORIES  
REQUIREMENTS





## SLEEVE INSTALLATION INSTRUCTIONS

### Attaching Fire Dampers to Sleeves

Fire dampers must be attached to sleeves as shown in Fig. 1. All four sides of the damper frame must be attached to the sleeve with one row of attachments on each side of the blade channel. Attachments must be spaced a maximum of 6" on centers and a maximum of 2" from corners. A minimum of 4 attachments (2 on each side of the blade channel) per side (16 per damper) are required. One of the methods of attachment shown below must be used.

- tack or spot welds
- No.10 sheet metal screws
- 1/4" bolts and nuts
- 3/16" steel pop rivets

### Securing Fire Damper and Sleeves to Wall and Floor Openings

Fire damper and sleeve assemblies must be installed in wall and floor openings using retaining angles on each side of the wall or floor as described below:

- Retaining angles must be a minimum of 16 gauge steel and have a minimum of 1-1/2" x 1-1/2" legs.
- Retaining angles must be attached to the sleeve using the procedures and methods described in section 3. The angles must be attached to all 4 sides of the sleeve with butt joints at each corner. A minimum of two attachments are required on each side, top and bottom. The angles need not be attached to each corner. A minimum of two attachments are required on each side, top and bottom. The angles need not be attached to each other at the corners.
- Retaining angles must completely cover the clearance space between the sleeve and the wall/ floor opening, plus overlap the wall/floor a minimum of 1". This coverage includes all corners (fig. 2).
- Retaining angles should not be fastened to the wall/ floor material. The angles should only sandwich the wall/floor and allow for damper/sleeve expansion during periods of intense heat.
- For grille installation, angle legs may be reversed and one leg inserted into the wall/floor opening providing the required clearance is maintained between angle leg fasteners and the wall/ opening.

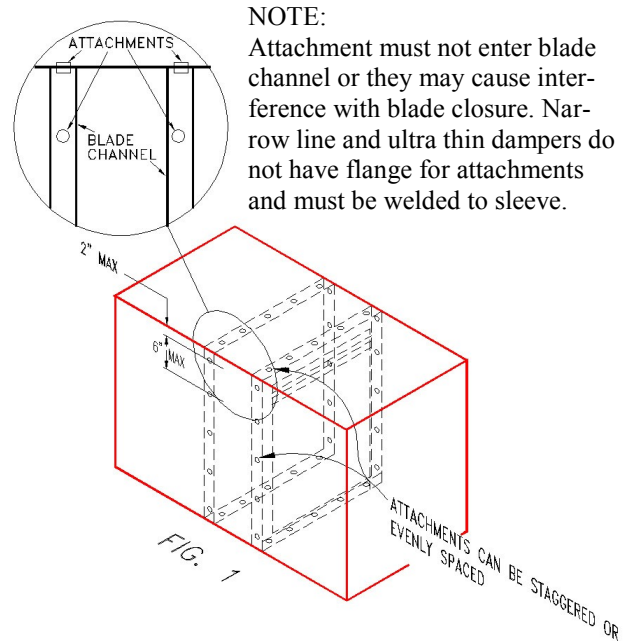

**NOTE:**

Attachment must not enter blade channel or they may cause interference with blade closure. Narrow line and ultra thin dampers do not have flange for attachments and must be welded to sleeve.

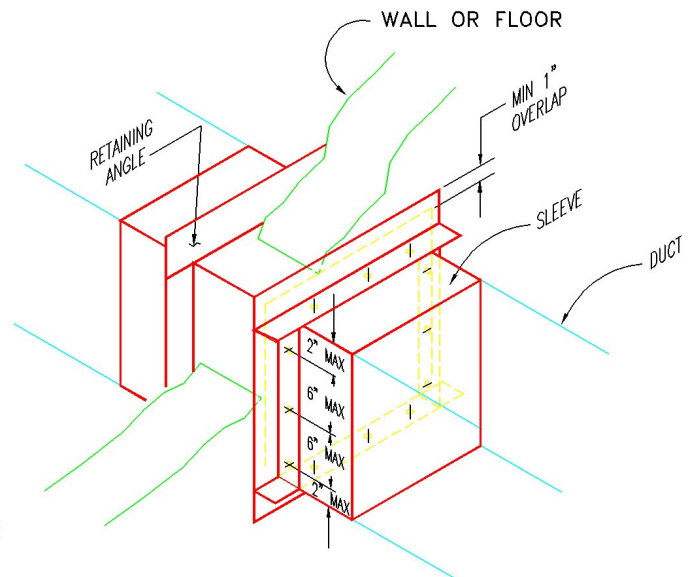

Fig. 2

### Multiple section fire dampers

When multiple sections are shipped unassembled, installer shall fasten dampers together.



INSTALLATION INSTRUCTIONS  
IN CONFORMANCE TO  
UNDERWRITERS LABORATORIES  
REQUIREMENTS





## SINGLE SIDE RETAINING ANGLE

### INSTALLATION INSTRUCTIONS VERTICAL OR HORIZONTAL MOUNT 1-1/2 OR 3 HR RATING

“Lloyd Rapid Mounting Angles” (For use on one sided angle installations)

These instructions apply to 1-1/2 or 3Hours rated combination fire/smoke, smoke, dynamic, curtain fire dampers and fire doors mounted in masonry, block, or metal, stud walls and floor.

Angles shall be a minimum of 1-1/2” x 1-1/2” x 16 gauge for openings in metal stud, and concrete/ masonry walls and floors of 48”x36” and less. Mounting angles are only required on one side of the wall or top of the floor. They must be attached to both the sleeve and the wall. Mounting angles may be installed directly to the metal stud under the wall board on metal installations only. Size larger will require the previous retaining angle design which consisted of 4 separate angles per side.

For one sided Lloyd Rapid Mounting Angle installations, the sleeve fasteners shall be no. 10 sheet metal screws spaced 3” from each end and no greater than 12” on center.

With a minimum of two(2) fasteners on each side, top and bottom.

Wall/floor fasteners shall be no. 10 sheet metal screws 2” long, two screws on each side angle spaced 3 inches from each end; three screws on each head and sill angle with one screw in the center and one at each end spaced 3 inches from the ends.

Screw fasteners used in metal stud must engage the metal stud a minimum of 1/2”

Screw fasteners used in masonry walls or floors must engage the wall or floor a minimum of 2”.

Angles should overlap the partition a minimum of 1” around the entire opening.

Installation per NFPA.90A, UL555, and SMACNA Fire Smoke and Radiation Installation Guide.

**FASTENERS MUST BE PLACED WHERE THEY DO NOT INTERFERE WITH THE DAMPER OPERATION.**

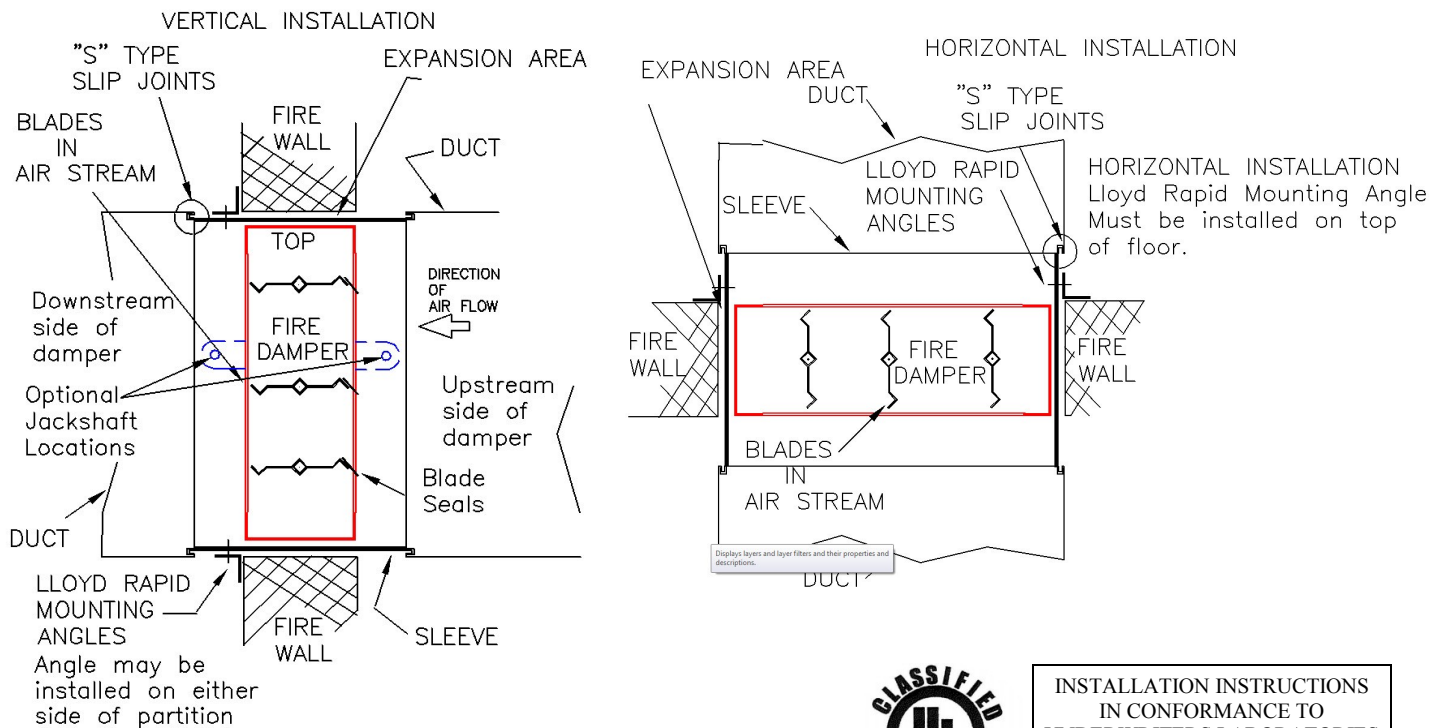

INSTALLATION INSTRUCTIONS  
IN CONFORMANCE TO  
UNDERWRITERS LABORATORIES  
REQUIREMENTS





## DAMPER INSTALLATION INSTRUCTIONS

**1-1/2 hour rated, UL classified model 75 fire dampers**  
**For use in fire barriers with ratings of less than 3hours**  
**“Fast mount” single side mounting angles**  
**METAL STUD WALL WITH THRU DUCTING**

### INSPECTION

Inspect for shipping damage.  
Inspect for proper size and model.  
Inspect installed damper for proper orientation, as stated on damper label.  
Inspect for obstruction which could interfere with free operation and complete closure.  
Manually cycle the damper to verify proper operation.

### INSTALLATION

The basic intent of a proper installation is to secure the fire damper in, not to, the opening in such a manner as to prevent distortion and disruption of the damper operation by allowing the fire damper in openings to expand and the connecting duct to separate in the event of the collapse of the hanging system. The fire damper must be positioned within the masonry, block or gypsum wallboard fire barrier.

### DAMPER TO SLEEVE ATTACHMENT

A Sleeve shall be used of sufficient length to permit direct attachment of perimeter mounting angles. This damper can be supplied by the factory mounted in a sleeve. If the sleeve is not factory supplied, it must be attached on both sides of the damper by one of the following methods:

Secure with 1/4” dia. Bolts and nuts or by welding with beads 1/2” in length, or with No.10 steel sheet metal screws, or 3/16” steel rivets. Fasteners shall be 8” maximum on centers. Fasteners cannot be placed where they will interfere with damper operation. Gaps at corners between the damper and its sleeve must be small enough to prohibit the passage of an 1/8” diameter rod through the entire depth of the gap between two damper panels and its sleeve.

### METAL STUD & MOUNT ANGLE ATTACHMENT

Secure “Fast Mount Angles” to sleeve & metal studs using the following options (8) connections on sleeve to angles: (2) connections on each parallel angle as a minimum. Mounting Angles may be mounted over or under drywall.

1. Steel sheet metal screws #8 to #12
2. Steel rivets 3/16” diameter “Pop, Hollow, or Solid.”
3. Steel Bolts & Nuts 1/4” diameter or greater.
4. Welding using 1/2” lg beads min.
5. Spot welding

### SLEEVE THICKNESS

Sleeves shall be the same gauge or heavier as the duct to which it is attached. Gauges shall conform to SMACNA or ASHRAE duct standards. Damper sleeve can be no thicker than 10ga. steel. On type C dampers, the sleeve must be 20ga. or heavier.

### EXPANSION CLEARANCE

The opening in the wall or floor for the fire damper shall be sized so as to provide expansion clearance between the sleeve and opening. Clearances do not vary with walls constructed of different materials. A minimum of 1/8” per foot of overall damper/sleeve width and height is required. The maximum opening size shall not exceed 1/8”.

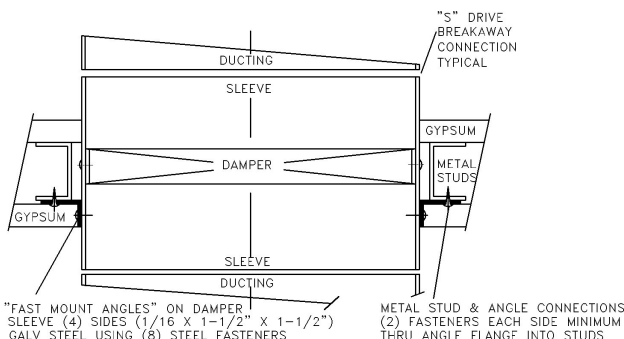
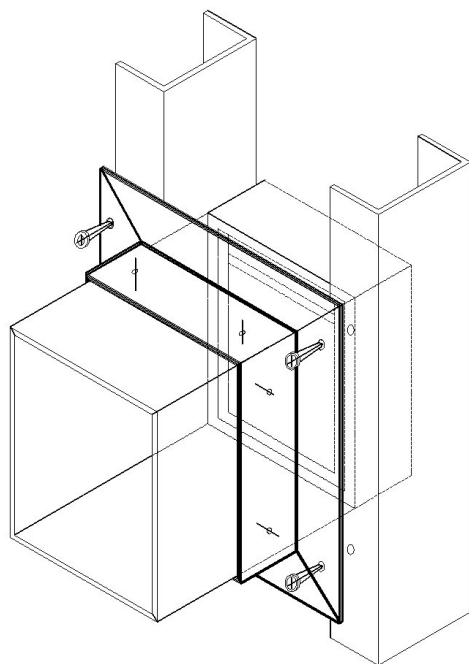

INSTALLATION INSTRUCTIONS  
IN CONFORMANCE TO  
UNDERWRITERS LABORATORIES  
REQUIREMENTS





## DAMPER INSTALLATION INSTRUCTIONS

### TRANSFER OPENINGS AND DUCT TERMINALS FOR 1-1/2 HOUR AND 3 HOUR CURTAIN FIRE DAMPERS 75A DAMPERS

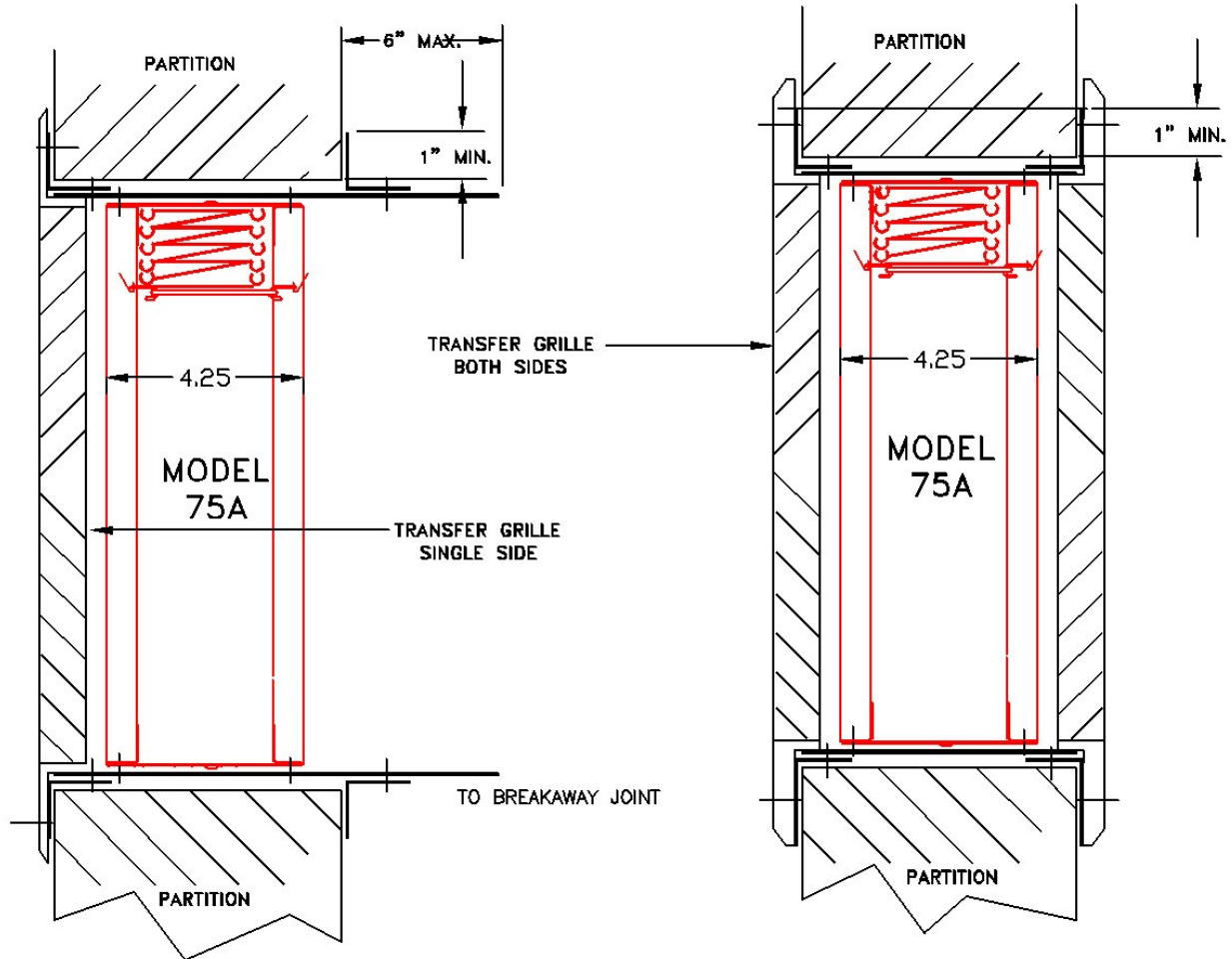

1. Perimeter mounting angles to be a minimum of 1-1/2" x 1-1/2" x 16 ga. on dampers 36" x 50" and smaller. For dampers greater than 36" x 50", angles to be a minimum of 1-1/2" x 1-1/2" x 14ga.
2. Grille to flange fasteners cannot penetrate the fire wall.
3. Secure angles to sleeve only, so as to frame the wall opening. Fasten to the sleeve only using the same means as required for fastening the damper to the sleeve.
4. Grille to flange attachment by means of 1/4" dia. Pop rivets, #8 sheet metal screws or #8 bolts and nuts. Fasteners to be plated steel or stainless steel, minimum two fasteners per side.



INSTALLATION INSTRUCTIONS  
IN CONFORMANCE TO  
UNDERWRITERS LABORATORIES  
REQUIREMENTS





## DAMPER INSTALLATION INSTRUCTIONS

### TRANSFER OPENINGS AND DUCT TERMINALS FOR 1-1/2 HOUR AND 3 HOUR CURTAIN FIRE DAMPERS 75D DAMPERS

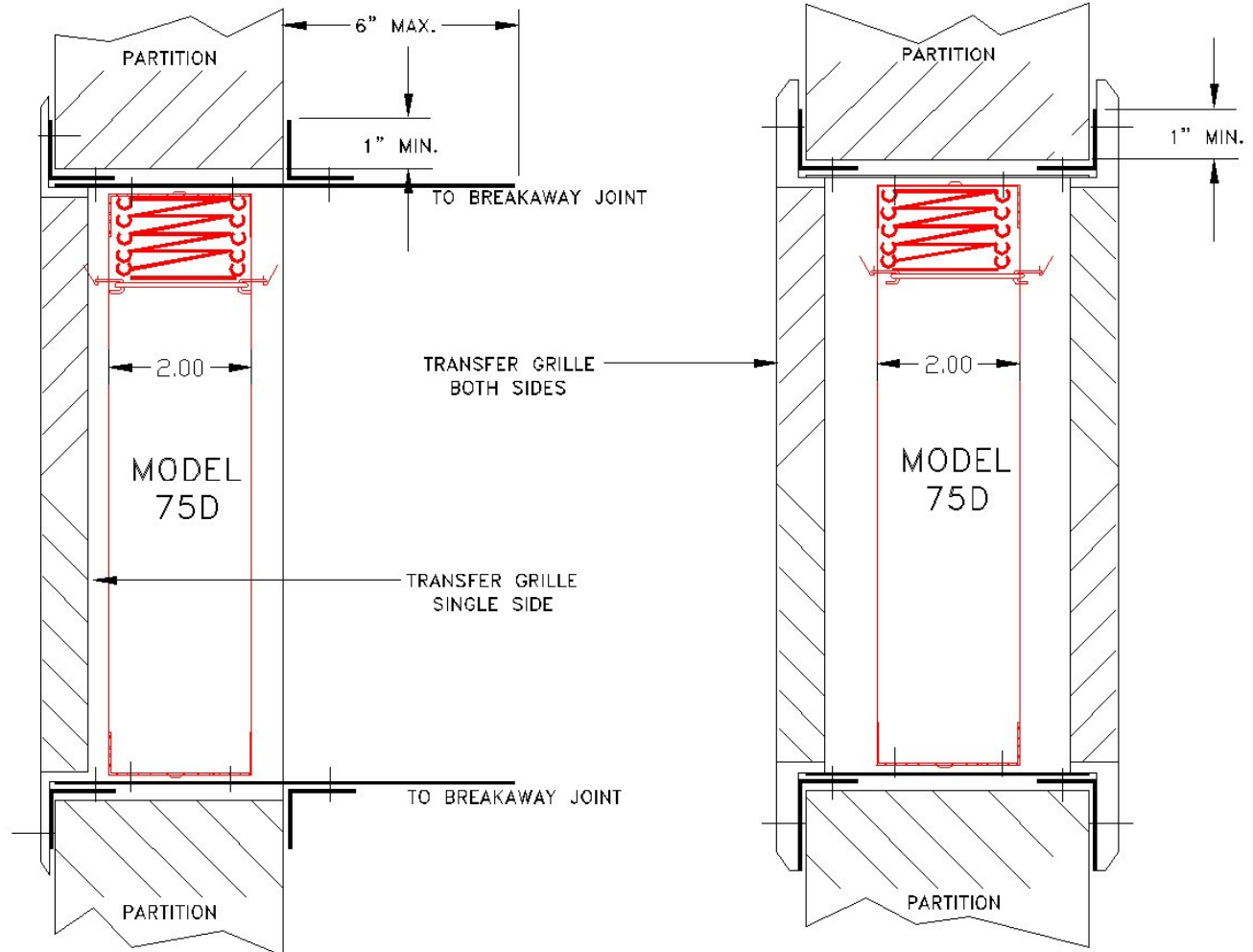

1. Perimeter mounting angles to be a minimum of 1-1/2" x 1-1/2" x 16 ga. on dampers 36" x 50" and smaller. For dampers greater than 36" x 50", angles to be a minimum of 1-1/2" x 1-1/2" x 14ga.
2. Grille to flange fasteners cannot penetrate the fire wall.
3. Secure angles to sleeve only, so as to frame the wall opening. Fasten to the sleeve only using the same means as required for fastening the damper to the sleeve.
4. Grille to flange attachment by means of 1/4" dia. Pop rivets, #8 sheet metal screws or #8 bolts and nuts. Fasteners to be plated steel or stainless steel, minimum



INSTALLATION INSTRUCTIONS  
IN CONFORMANCE TO  
UNDERWRITERS LABORATORIES  
REQUIREMENTS

