

Sustainable Coils LLC

Replacement Coil Solutions!

F-series Air Handlers

Replacement coils for Carrier, Bryant, Payne, Arcoaire, Comfortmaker, Day & Night, Heil, Tempstar and ICP private brands

Sustainable Coils is proud to offer an affordable solution for F-Series Air Handler coils that have failed and are no longer in warranty.

1. Our slope coil line set connections are properly positioned to match the existing air handler cover plate. The end brackets are slotted to accept the coil support brackets from the old unit. The end brackets of the slope coil have pilot holes for attachment of the existing drain pan. Plus, we furnish a factory installed top attachment baffle for ease of installation. **The existing drain pan and leg supports must be reused.**
2. The A-coil replacements have a properly sized G-90 22 gauge paint grip metal drain pan that is coated for rust protection. The drain connections are positioned to fit the access panel and the pan is equipped with drain pan brackets already attached to the bottom of the pan. The A-coil line sets are positioned to match the existing access panel. The 314A2430, 318A4248 and 324A4860 top baffle is sized to accept the Air Seal Assembly from the existing coil if the coil is used in a horizontal application. The 424A60+TXV has been re-engineered from a 3 row coil to a 4 row coil to eliminate skid only shipping issues. The new 4 row coil maintains the correct internal refrigerant volume, drain pan and line set connection locations. The coil is 6" shorter and does not need the Air seal assembly from the old coil in horizontal applications.
3. We have maintained the proper internal refrigerant volumes for each model to ensure compatibility for heat pump applications.
4. All F-Series replacement coils utilize, 3/8" O.D., CU-122 60 helical copper tube, .016 back wall. With a backwall thickness of .016, our coils have a 2,500 PSI burst pressure minimum which far exceeds industry standards.
5. Our F-Series replacement coils carry a Five year replacement warranty for added end user peace of mind, instead of the one year replacement warranty currently available when using the OEM coil in a replacement application.

It may be necessary to change out the metering device depending upon your refrigerant and replacement model application. Additional pistons and TXV for R22 and R410A are available from the factory.

Telephone: (903) 881-6006

Fax: (903) 881-6008

Email: sales@SustainableCoils.com

Sustainable Coils LLC

Replacement Coil Solutions!

Carrier/Bryant/ICP F-series Air Handler replacement coils

Revision Date: 10/09/2023

SLOPE MODEL	COIL WEIGHT	Face Area	Rows	G	B	F	G
318S2430	20	2.23 sq ft	3	21"	18"	3/8	3/4
324S3036	26	2.97 sq ft	3	21"	24"	3/8	3/4
328S3642	30	3.46 sq ft	3	21"	28"	3/8	7/8

** Denotes limited stock item, please contact factory for availability

All slope coils have the following characteristics in common:

- Pre-punched brackets to accept coil support columns
- Pre-installed side block off baffles for proper fit
- Pre-installed coil top seal
- Line sets positioned to fit access panel location

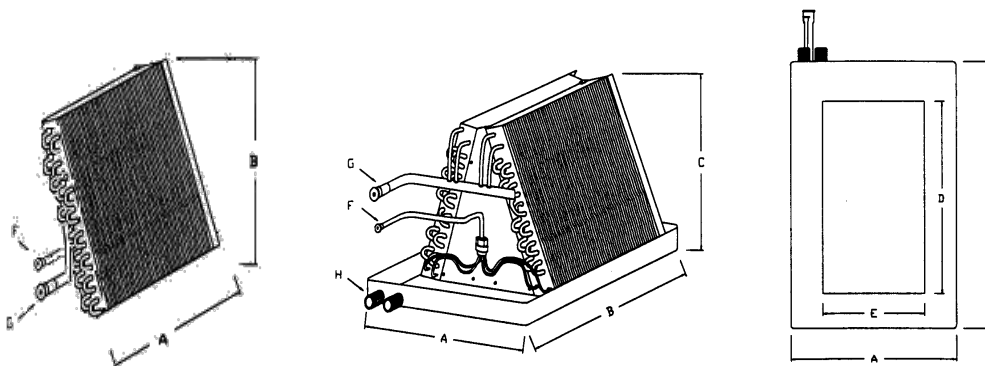

A-coil pictured above for dimensional use only and does not accurately depict liquid and suction line location.

"A" MODEL	COIL WEGHT	A	B	C	D	E	F	G	H
*314A2430	36	15 3/4	20 5/8	14 1/2	16	9 3/4	3/8	3/4	3/4
*318A4248	40	19 1/4	20 5/8	18 1/2	16	13 1/4	3/8	7/8	3/4
*324A4860	49	19 1/4	20 5/8	24 1/2	16	13 1/4	3/8	7/8	3/4
*324A4860W	52	22 3/4	20 5/8	24 1/2	16	16 1/4	3/8	7/8	3/4
424A60+2X (+4X)	58	22 3/4	20 5/8	24 1/2	16 1/2	14 1/4	3/8	7/8	3/4

*A-coil top baffle sized to accept horizontal top seal from replaced coil

- Metal drain pan coated for rust protection; drains match air handler access panel location
- Drain pan equipped with coil brackets for proper mounting
- 3/8" O.D., CU-122 60 helical copper tube, .016 back wall
- 2,500 PSI burst pressure minimum
- All coils utilize aluminum end plates for rust reduction
- All coils maintain proper Internal Refrigerant Volumes for heat pump compatibility
- All suction and liquid lines positioned to air handler access panel location
- Line sets pre-swaged, coils shipped with dry nitrogen holding charge
- Five year replacement warranty

For printable line art and cross reference utilization chart PDF please visit our website at www.SustainableCoils.com.

Telephone: (903) 881-6006

Fax: (903) 881-6008

email: sales@sustainablecoils.com

Sustainable Coils LLC

Replacement Coil Solutions!

F-SERIES AIR HANDLER CROSS REFERENCE UTILIZATION CHART

Carrier, Bryant, Payne F-Series Air Handler models: FA4A, FA4B, FA4C, FB4A, FB4B, FB4C, FC4B, FC4C, FC4D, FE4A, FE5A, FK4C, FK4D, FV4A, FV4B, FV4C, FX4B, FX4C, FX4D, FY4A, PF1MNA, PF1MNB, PF1MNC, PF4MNA and PF4MNB:

10/09/2023

“S” in the model number designates slope coil, “A” designates A-coil. If your air handler model is not shown, please consult your Wholesale Distributor or contact the factory for the correct coil model number.

Please note: Due to the multiple uses of the coil model numbers in various tonnages and air handlers, it may be necessary to change out the piston or field install a Sustainable Coils TXV for a proper match to the outdoor unit. Replacement coils may be ordered with the correct piston or TXV factory installed with a minimal up-charge to fit the desired application. Please consult your Wholesale Distributor or the factory to verify the correct metering device needed for your refrigerant application.

The 424A60+TXV is a drop in replacement that does not replicate the original coil. The 424A60+TXV is a 4 row coil with a factory installed TXV that is 24 1/2” tall. It is manufactured to fit into the 26 11/16” wide air handlers. The original coil that it replaces is a 3 row 30” tall coil with a 7.42 sq. ft. face area. The internal refrigerant volumes of both coils match for heat pump application compatibility, plus the drains and line set connections match the access panel. Due to the 4 row configuration, the horizontal top seal from the original coil will not fit the top baffle. Since the coil is 6” shorter than the original coil, it may be used in a horizontal application without the top seal.

OEM Model #	Sustainable Model #	Specified Metering
FA4ANF018	318S2430	Piston
FA4ANF024	318S2430	Piston
FA4ANF030	324S3036	Piston
FA4ANF036	324S3036	Piston
FA4ANF042	328S3642	Piston
FA4ANF048	318A4248	Piston
FA4ANF060	324A4860	Piston

OEM Model #	Sustainable Model #	Specified Metering
FA4BNF018	318S2430	Piston
FA4BNF024	318S2430	Piston
FA4BNF030	324S3036	Piston
FA4BNF036	324S3036	Piston
FA4BNF042	328S3642	Piston
FA4BNF048	318A4248	Piston
FA4BNF060	324A4860	Piston

Carrier, Bryant, Payne F-Series Air Handler cross reference:

10/09/2023

Page 2

OEM Model #	Sustainable Model #	Specified Metering
FA4CNF018	318S2430+2X	R-22 TXV
FA4CNF024	324S3036+2X	R-22 TXV
FA4CNF030	324S3036+2X	R-22 TXV
FA4CNF036	328S3642+2X3	R-22 TXV
FA4CNF042	318A4248+2X	R-22 TXV
FA4CNF048	324A4860+2X	R-22 TXV
FA4CNB060	424A60+2X	R-22 TXV

OEM Model #	Sustainable Model #	Specified Metering
FB4ANF018	318S2430	Piston
FB4ANF024	318S2430	Piston
FB4ANF030	324S3036	Piston
FB4ANF036	324S3036	Piston
FB4ANF042	328S3642	Piston
FB4ANF048	318A4248	Piston
FB4ANF060	324A4860	Piston
FB4ANF070	424A60+2X	R-22 TXV

OEM Model #	Sustainable Model #	Specified Metering
FB4BNF018	318S2430	Piston
FB4BNF024	318S2430	Piston
FB4BNF030	324S3036	Piston
FB4BNF036	324S3036	Piston
FB4BN(B,F)042	328S3642	Piston
FB4BN(B,F)048	318A4248	Piston
FB4BN(B,F)060	324A4860	Piston
FB4BNB070	424A60+2X	R-22 TXV

OEM Model #	Sustainable Model #	Specified Metering
FB4CNF018	318S2430	Piston
FB4CNF024	318S2430	Piston
FB4CNF030	324S3036	Piston
FB4CNF036	324S3036	Piston
FB4CNF042	318A4248	Piston
FB4CNF048	318A4248	Piston
FB4CNF060	324A4860+2X	R-22 TXV

OEM Model #	Sustainable Model #	Specified Metering
FC4BNF024	318S2430+2X	R-22 TXV
FC4BNF030	324S3036+2X	R-22 TXV
FC4BNF036	324S3036+2X	R-22 TXV
FC4BNF038	324A4860+2X3	R-22 TXV
FC4BNF042	328S3642+2X	R-22 TXV
FC4BN(B,F)048	318A4248+2X	R-22 TXV
FC4BNF054	424A60+2X	R-22 TXV
FC4BNF060	324A4860+2X	R-22 TXV
FC4BNF070	424A60+2X	R-22 TXV

Carrier, Bryant, Payne F-Series Air Handler cross reference:

10/09/2023

Page 3

OEM Model #	Sustainable Model #	Specified Metering
FC4CNF024	318S2430+2X	R-22 TXV
FC4CNF030	324S3036+2X	R-22 TXV
FC4CNF036	324S3036+2X	R-22 TXV
FC4CNF042	328S3642+2X	R-22 TXV
FC4CNF048	318A4248+2X	R-22 TXV
FC4CNB054	424A60+2X	R-22 TXV
FC4CNF060	324A4860+2X	R-22 TXV
FC4CNB070	424A60+2X	R-22 TXV

OEM Model #	Sustainable Model #	Specified Metering
FC4DNF018	318S2430+2X	R-22 TXV
FC4DNF024	324S3036+2X	R-22 TXV
FC4DNF030	324S3036+2X	R-22 TXV
FC4DN(B,F)036	328S3642+2X3	R-22 TXV
FC4DN(B,F)042	318A4248+2X	R-22 TXV
FC4DN(B,F)048	324A4860+2X	R-22 TXV
FC4DN(B,F)060	424A60+2X	R-22 TXV

OEM Model #	Sustainable Model #	Specified Metering
FE4ANF002	314A2430+4X	R-410A TXV
FE4AN(B,F)003	328S3642+4X	R-410A TXV
FE5ANB004	424A60+4X3	R-410A TXV
FE4AN(B,F)005	324A4860+4X	R-410A TXV
FE4ANB006	424A60+4X	R-410A TXV

OEM Model #	Sustainable Model #	Specified Metering
FK4CNF001	324S3036+2X	R-22 TXV
FK4CNF002	314A2430+2X	R-22 TXV
FK4CNF003	328S3642+2X	R-22 TXV
FK4CNF005	324A4860+2X	R-22 TXV
FK4CNB006	424A60+2X	R-22 TXV

OEM Model #	Sustainable Model #	Specified Metering
FK4DNF001	324S2430+2X	R-22 TXV
FK4DNF002	314A2430+2X	R-22 TXV
FK4DN(B,F)003	328S3642+2X	R-22 TXV
FK4DN(B,F)005	324A4860+2X	R-22 TXV
FK4DNB006	424A60+2X	R-22 TXV

OEM Model #	Sustainable Model #	Specified Metering
FV4ANF002	314A2430+4X	R-410A TXV
FV4ANF003	328S3642+4X3	R-410A TXV
FV4ANF005	324A4860+4X	R-410A TXV
FV4ANB006	424A60+4X	R-410A TXV

OEM Model #	Sustainable Model #	Specified Metering
FV4BNF002	314A2430+4X	R-410A TXV
FV4BNF003	328S3642+4X3	R-410A TXV
FV4BNF005	324A4860+4X	R-410A TXV
FV4BNF006	424A60+4X	R-410A TXV

Carrier, Bryant, Payne F-Series Air Handler cross reference:

10/09/2023

Page 4

OEM Model #	Sustainable Model #	Specified Metering
FV4CNF002	314A2430+4X	R-410A TXV
FV4CN(B,F)003	328S3642+4X3	R-410A TXV
FV4CN(B,F)005	324A4860+4X	R-410A TXV
FV4CNB006	424A60+4X	R-410A TXV

OEM Model #	Sustainable Model #	Specified Metering
FX4ANF030	324S3036+4X	R-410A TXV
FX4ANF036	328S3642+4X3	R-410A TXV
FX4ANF042	318A4248+4X	R-410A TXV
FX4ANF048	324A4860+4X	R-410A TXV
FX4ANF060	424A60+4X	R-410A TXV

OEM Model #	Sustainable Model #	Specified Metering
FX4BNF018	318S2430+4X	R-410A TXV
FX4BNF030	324S3036+4X	R-410A TXV
FX4BNF036	328S3642+4X3	R-410A TXV
FX4BNF042	318A4248+4X	R-410A TXV
FX4BNF048	324A4860+4X	R-410A TXV
FX4BNF060	424A60+4X	R-410A TXV

OEM Model #	Sustainable Model #	Specified Metering
FX4CNF018	318S2430+4X	R-410A TXV
FX4CNF024	324S3036+4X	R-410A TXV
FX4CNF030	324S3036+4X	R-410A TXV
FX4CN(B,F)036	328S3642+4X3	R-410A TXV
FX4CN(B,F)042	318A4248+4X	R-410A TXV
FX4CN(B,F)048	324A4860+4X	R-410A TXV
FX4CN(B,F)060	424A60+4X	R-410A TXV

OEM Model #	Sustainable Model #	Specified Metering
FX4DNF019	324S3036+4X	R-410A TXV
FX4DNF025	324S3036+4X	R-410A TXV
FX4DN(B,F)031	328S3642+4X3	R-410A TXV
FX4DN(B,F)037	318A4248+4X3	R-410A TXV
FX4DN(B,F)043	318A4248+4X	R-410A TXV
FX4DN(B,F)049	324A4860W+4X	R-410A TXV
FX4DN(B,F)061	424A60+4X	R-410A TXV

OEM Model #	Sustainable Model #	Specified Metering
FY4ANF018	318S2430+4X	R-410A TXV
FY4ANF024	324S3036+4X	R-410A TXV
FY4ANF030	324S3036+4X	R-410A TXV
FY4ANF036	328S3642+4X3	R-410A TXV
FY4ANF042	318A4248+4X	R-410A TXV
FY4ANF048	324A4860+4X	R-410A TXV
FY4ANB060	424A60+4X	R-410A TXV

Carrier, Bryant, Payne F-Series Air Handler cross reference:

10/09/2023

Page 5

OEM Model #	Sustainable Model #	Specified Metering
PF1MNA018	318S2430	Piston
PF1MNA024	318S2430	Piston
PF1MNA030	324S3036	Piston
PF1MNA036	324S3036	Piston
PF1MNA042	328S3642	Piston
PF1MNA048	318A4248	Piston
PF1MNA060	324A4860	Piston
PF1MNA070	424A60	Piston
PF1MNA071	424A60+2X	R-22 TXV

OEM Model #	Sustainable Model #	Specified Metering
PF1MNB018	318S2430	Piston
PF1MNB024	318S2430	Piston
PF1MNB030	324S3036	Piston
PF1MNB036	324S3036	Piston
PF1MNB042	328S3642	Piston
PF1MNB048	318A4248	Piston
PF1MNB060	324A4860	Piston
PF1MNB070	424A60	Piston
PF1MNB071	424A60+2X	R-22 TXV

OEM Model #	Sustainable Model #	Specified Metering
PF1MNC018	318S2430+2X	R-22 TXV
PF1MNC024	324S3036+2X	R-22 TXV
PF1MNC030	324S3036+2X	R-22 TXV
PF1MNC036	328S3642+2X3	R-22 TXV
PF1MNC037	328S3642+2X3	R-22 TXV
PF1MNC042	318A4248+2X	R-22 TXV
PF1MNC043	318A4248+2X	R-22 TXV
PF1MNC048	324A4860+2X	R-22 TXV
PF1MNC049	324A4860+2X	R-22 TXV
PF1MNC060	424A60+2X	R-22 TXV
PF1MNC061	424A60+2X	R-22 TXV

OEM Model #	Sustainable Model #	Specified Metering
PF4MNA018	318S2430+4X	R-410A TXV
PF4MNA019	318S2430+4X	R-410A TXV
PF4MNA024	324S3036+4X	R-410A TXV
PF4MNA025	324S3036+4X	R-410A TXV
PF4MNA030	324S3036+4X	R-410A TXV
PF4MNA031	324S3036+4X	R-410A TXV
PF4MNA036	328S3642+4X3	R-410A TXV
PF4MNA037	328S3642+4X3	R-410A TXV
PF4MNA042	318A4248+4X	R-410A TXV
PF4MNA043	318A4248+4X	R-410A TXV
PF4MNA048	324A4860+4X	R-410A TXV
PF4MNA049	324A4860+4X	R-410A TXV
PF4MNA060	424A60+4X	R-410A TXV
PF4MNA061	424A60+4X	R-410A TXV

Telephone: (903) 881-6006

Fax: (903) 881-6008

email: sales@SustainableCoils.com

Carrier, Bryant, Payne F-Series Air Handler cross reference:

10/09/2023

Page 6

OEM Model #	Sustainable Model #	Specified Metering
PF4MNB019	324S3036+4X	R-410A TXV
PF4MNB025	324S3036+4X	R-410A TXV
PF4MNB031	328S3642+4X3	R-410A TXV
PF4MNB037	318A4248+4X3	R-410A TXV
PF4MNB043	318A4248+4X4	R-410A TXV
PF4MNB049	324A4860+4X5	R-410A TXV
PF4MNB061	424A60+4X5	R-410A TXV

3/8 O.D., CU-122 60 helical copper tube, .016 back wall

2,500 PSI burst pressure minimum

Aluminum end plates for rust reduction

Piston models metered for R-22 applications, R-410A pistons available upon request

Expansion valve kits with chatleff fittings available upon request

Factory installed expansion valves available upon request

Suction and liquid lines positioned to access panel locations

Pre-swaged suction and liquid lines, shipped with dry nitrogen holding charge

A-coils utilize a G-90 paint grip metal coated drain pan with coil brackets

A-coil drains positioned to match access panel

314A2430, 318A4248 and 324A4860 top baffle sized to accept horizontal top seal from old coil.

424A60+TXV top baffle will not accept the horizontal top seal

Proper internal refrigerant volumes maintained for heat pump compatibility

Coils carry a Five year replacement warranty from date of installation

Proudly manufactured and assembled in Lindale, Texas