

PIONEER IRRIGATION DISTRICT
STANDARDS AND SPECIFICATIONS

PIONEER IRRIGATION DISTRICT
Caldwell, Idaho

Revised: February 2019

Prepared by:
SPF WATER ENGINEERING, LLC
Boise, Idaho

Signature Page

Per the Idaho Administrative Code (IDAPA) Section 10.01.02 and Idaho Code Title 42, Chapter 12, Pioneer Irrigation District retained SPF Water Engineering, LLC to prepare the following Pioneer Irrigation District Standards and Specifications to ensure said Standards and Specifications meet the requisite standards of professional engineering thereby safeguarding the life, health, property, and welfare of the public at large. Pioneer Irrigation District personnel are an integral part of the design and construction review process due to their extensive knowledge of the operation, maintenance, and proper function of District facilities. These Standards and Specifications comply with applicable professional engineering standards for the construction of irrigation systems and further comply with the engineering Rules of Professional Responsibility when consulted and used appropriately by design personnel.

Per Idaho Code 54-1218, a licensed professional engineer must prepare the plans and specifications for public works projects as well as supervise or conduct construction observation. Therefore, it is the sole responsibility of the Registered Professional Engineer who is using the Pioneer Irrigation District Standards and Specifications for a specific project to ensure that the Standards and Specifications and drawings are appropriate for the specific use and used appropriately under all circumstances in order to prepare final specifications, drawings, or plans for any given project.

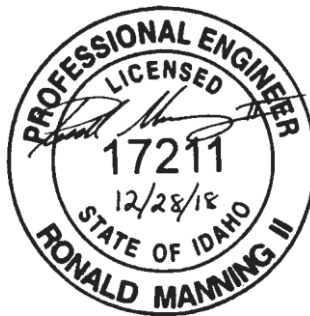

Table of Contents

1000	FEES	4
1100	PRESSURE IRRIGATION SYSTEMS.....	4
1200	GRAVITY FLOW IRRIGATION	4
1201	Preservation of Existing Use and Delivery.....	4
1202	Drains.....	4
1203	Gravity Irrigation Plan.....	5
1204	Pipe Installation	10
1205	Concrete Structure Requirements for Gravity Systems	12
1206	Bridges/Crossings.....	13
1207	Control Structures.....	14
1208	Final Observation & Testing Prior to Warranty Period.....	15
1209	Street Crossing Requirements	15
1210	Structure Lids	15
1211	Method of Measurement and Basis of Payment (For PID Projects)	16
1300	ADDITIONAL REQUIREMENTS	16
1301	Construction Deadlines	16
1302	Financial Responsibility	16
1303	Request Deadlines	18
1304	Delivery Point.....	18
1305	Contractor Licensing	18
1306	Plan Submittal and Review	19
1307	Construction Observation.....	20
1308	Final Acceptance	20
1309	Pavement Removal and Restoration.....	21
1310	Easement Requirements	21
1311	Fencing Recommendations for New Developments.....	23
1312	Professional Engineer Requirement	23
1313	Record Drawings.....	23
1314	Construction Warranty	23
1315	License Agreement.....	24
1316	Landscaping and Improvement Restrictions	24
1317	Stormwater Discharge into District Facilities	25

**PIONEER IRRIGATION DISTRICT SUPPLEMENTAL
SPECIFICATIONS AND STANDARDS *Effective: February 2019***

STANDARD

The provisions of the current edition of the Idaho Standards for Public Works Construction (*ISPWC-2015 Edition*) and the following modifications and supplementation contained herein constitute the Pioneer Irrigation District Standard Specifications for work performed under the administration of the Pioneer Irrigation District, referred to as **PID**. These standard specifications supersede any and all previous standard specifications for **PID**.

PID's water distribution system functions as a continuous flow system. Consequently, any changes in existing canals, ditches, or drains could disrupt the operation of this continuous flow system unless components of this system are preserved and protected.

Therefore, in any proposal which impacts **PID** owned facilities or facilities owned by others which are used by **PID**, or in which **PID** has a property interest, such as a ditch use/irrigation easement or right-of-way, **PID** requires that all such facilities and **PID's** property interest therein be preserved and protected as part of any agreement with the person or entity who presents the proposal to **PID**.

Further, because of the various legal duties owed by **PID**, including those under Idaho Code Sections 42-1201 through 42-1204 and 43-304 and 43-316, among others, and pursuant to the written permission requirements of Idaho Code Sections 42-1102, 42-1207, and 42-1209, any developer/landowner proposing to encroach upon a **PID** easement or facility, including the crossing of the same, or proposing to relocate, realign, modify, or pipe a **PID** facility shall submit a written request to do so in the form of **PID's** Land Use Change/Encroachment Application form. All such requests/proposals are subject to **PID** licensing agreement requirements, and some requests/proposals may be subject to additional **PID** Board hearing requirements under the District's published Procedures for Evaluation of Proposed Encroachments.

Any person or entity proposing modifications to a **PID** facility shall bear the initial expense of the modification, any increased operation and maintenance costs caused by the modification, and the future facility rehabilitation and replacement costs. The **PID** Board of Directors, may waive the future rehabilitation and replacement cost requirement for projects where **PID** determines, in its sole discretion, that the proposed facility modification will provide a benefit to **PID** versus leaving the facility in its current location, state, or configuration.

PID shall also follow these standards for construction projects completed by or on behalf of **PID**.

1000 FEES

Pioneer Irrigation District has determined the following fee schedule for calendar year 2019. Fees are subject to change on an annual basis. These fees are imposed to cover the District’s costs related to encroachment procedures, license agreement preparation, consultation(s), plan and easement review(s), site visit(s), and correspondence by the District Engineer. Additional costs incurred for additional engineering plan review, additional site visits, etc. will be passed through PID to the applicant. The General Projects fee is an estimate based on a typical project. Larger and more complex projects may exceed this amount. Any remaining review funds not expended during the application review/approval process will be returned to the application following successful project completion. Additional fees are billed on a monthly basis and are due within 30 days of invoice date. Any invoice not paid within 30 days is subject to a 1.5% interest charge each month until the balance is paid in full, including potential suspension of the application review process.

Item	Fee
General Projects	\$2,300
Utility Projects	\$300
Temporary Irrigation Crossings	\$100
Special Board Meeting	\$1,200

1100 PRESSURE IRRIGATION SYSTEMS

Proposed developments shall provide pressure irrigation systems meeting the requirements of **PID** and the governing jurisdiction. The developer/landowner or his representative shall contact **PID** prior to pressure irrigation system design to determine the appropriate location of the District’s delivery point for the pressure irrigation system. Determining a delivery or pump location based upon water rights alone may not ensure adequate irrigation delivery.

1200 GRAVITY FLOW IRRIGATION

1201 Preservation of Existing Use and Delivery

All proposed development shall protect and preserve existing irrigation water use and delivery pursuant to, and consistent with, Idaho Code Sections 31-3805, 31-3806, and 67-6537. This includes development coordination with **PID** and the protection and preservation of existing irrigation delivery and removal infrastructure. When existing system preservation is not feasible, development shall provide an independent replacement gravity irrigation system. This system shall ensure delivery of as much gravity irrigation water as was delivered prior to construction/development. The delivery points to adjacent properties shall remain unchanged. The gravity flow irrigation system must be entirely separate from the proposed pressurized irrigation system within a subdivision. Flow rates for all replacement gravity systems shall be obtained from **PID** for design purposes. **PID** recommends that the downstream water users be contacted regarding any changes to be made to their delivery system. Further, please note that developer compliance with the above-referenced Code Sections is not a substitute for the additional requirements of Idaho Code Sections 42-1102, 42-1207, and 42-1209.

1202 Drains

Drains adjacent to and within **PID** boundaries are essential to the District and its patrons for lowering high groundwater, conveying **PID** irrigation supply facility discharges and conveying

irrigation return flows.

Any proposed improvements within Drain easements owned, operated or maintained by **PID** require the District's prior written plan approval. Requests to pipe Drains shall be submitted to **PID** and the **PID** Board will consider requests on a case by case basis. A **PID** or **United States Bureau of Reclamation** licensing agreement must be executed prior to construction.

Improvements impacting Drains providing irrigation supply to **PID** conveyance facilities shall be constructed during the deadlines outlined in Section 1300. Construction shall be in accordance to Section 1203 Gravity Irrigation Flow Piping standards at all locations including within road rights-of-way. Drains may require additional channel and bank stabilization as deemed necessary by **PID**.

The following Drains supply **PID** conveyance facilities:

Five Mile Drain, Ten Mile Drain, Fifteen Mile Drain, Elijah Drain, Mason Creek Drain, Pipe Gulch Drain, Purdum Drain, Solomon Drain, and Wilson Creek Drain

Developers/landowners shall contact **PID** to determine acceptable construction deadlines in all other Drains within **PID** boundaries.

Pathways to be constructed within **PID** Drain easements shall be located adjacent to the easement line and shall be no closer than 25 feet from the inside top of the adjacent bank.

Developers/landowners shall contact **PID** for Drain easement determination. Easements shall meet the requirements of Section 1310.

1203

Gravity Irrigation Plan

Any development proposing to relocate and/or pipe a **PID** facility shall provide a conceptual piping plan sent to **PID** for Board review and approval prior to final plan submittal. Proposed conceptual plans shall be reviewed on case-by-case basis.

No utilities shall be constructed within any **PID** easements parallel to canals, laterals, or other conveyance systems. Generally open channel realignment of **PID** owned and operated facilities is not acceptable. Modifications to the open channel will be reviewed for horizontal and vertical alignment.

If open channel realignment is approved by **PID**, no high fill areas or sharp deflections in channel alignment are acceptable. Piping and realignment project construction shall be completed in such a way as to minimize the amount of disturbance to the existing facility as possible.

Within realignment projects, no backfill shall be placed within the existing facility and no connection to existing facilities shall be made until **PID** inspections provide **PID** with a high level of assurance that the newly constructed alignment has been completed to **PID**'s satisfaction.

1203.01

Gravity Irrigation Flow Pipe

Typically, gravity flow piping that is to be maintained by **PID** shall be Class III reinforced concrete minimum or Class 125 PVC SDR 32.5 minimum. Pipe shall be labeled with manufacturer information and date of manufacture. **PID** reserves the right to reject pipe of questionable quality due to age or exposure to sunlight or other adverse conditions.

PVC SDR-35 or Poly-coated aluminized steel type 2 corrugated steel pipe (10 gage minimum wall

PIONEER IRRIGATION DISTRICT STANDARDS AND SPECIFICATIONS

thickness) may be permitted by **PID** in Drain crossing locations as determined by the **PID** Board on a case by case basis.

In access easements or rights-of-way where pipe is subject to wheel loading, pipe shall be Class IV reinforced concrete minimum, C-900 or C-905 PVC, Pressure Class 235 minimum, or with **PID** Board approval, poly-coated aluminized steel type 2 corrugated steel pipe with 2-2/3" x 1/2" corrugations with a 10 gauge (0.138-inch) minimum wall thickness. Pipe type and cover shall be sufficient to support a HS-25 loading.

All concrete pipes shall be manufactured in accordance with ASTM C76 Reinforced Concrete Pipe and tested in accordance with ASTM C 497. Joints shall be in accordance with ASTM C 443, Rubber Gasketed Joints. Installed pipe joints shall meet the maximum allowable joint gap requirements per the pipe manufacturer. Concrete pipe labeled non-air tested shall not be installed in **PID** delivery facilities. The **PID** Board and the District's engineer may allow non-air tested concrete pipe at crossings within drainage facilities, to be determined on a case by case basis.

All PVC pipe shall be manufactured in accordance with ASTM D 2241. Joints shall be bell and spigot end with ASTM F 477 elastomeric gaskets.

All aluminized steel type 2 corrugated steel pipe shall be manufactured in accordance with ASTM A760. The aluminized type 2 steel coils shall conform with ASTM A 929.

All gravity irrigation mains shall be a minimum of 12 inches in diameter and shall be designed and constructed to give mean velocities, when flowing full, of not less than 2.5 feet per second, based on Manning's formula using an "n" value of 0.013. Flow rates shall be obtained from **PID** for design purposes.

When a smaller gravity pipe joins a larger one, the invert of the larger pipe should be lowered sufficiently to maintain the same energy gradient. An approximate method for obtaining these results is to place the 0.8 depths of both pipes at the same elevation.

Piping shall be laid with uniform slope and alignment between manholes. Pipe lengths are required to be maximized to reduce the number of joints. Eight (8) foot lengths or twelve (12) foot lengths shall be utilized where possible.

Installation of finder wire attached to the top of pipe may be required as determined on a case by case basis.

If it is necessary to connect two dissimilar pipes together or two similar pipes where factory bell and spigot are not available; band seal couplers made by Mission Clay Products of Corona California, or **PID** Board approved equal, which provide a watertight connection and consistent pipe invert, shall be used.

Pipe bedding materials shall be in accordance with Section 1204.02.02

Pipe shall be provided with the following cover requirements unless otherwise specifically approved by the **PID** Board:

Pipe up to 24-inch diameter shall be provided with a minimum cover of 30 inches, and shall have a maximum cover of 48 inches.

Pipe greater than 24-inch diameter shall be provided with a minimum cover of 30 inches, and shall have a maximum cover of 36 inches, unless otherwise approved by **PID** Board.

1203.01.01 Siphons

No new siphons or inverted siphons are allowed. Siphons or inverted siphons existing prior to construction may be allowed on a case by case basis. If road reconstruction is required for the project existing siphons or inverted siphons shall be removed if possible.

1203.02 Utility Crossings

No above ground wet or pressurized utilities shall be constructed within PID easements outside of road rights-of-way.

Overhead utility crossings shall be reviewed and approved by the **PID** Superintendent or Board on a case by case basis, and may require a license agreement for approval.

1203.02.01 Underground Utility Crossings

Underground utility crossings shall be sleeved. Sleeves shall extend the entire width of the **PID** easement. Boring shall be required on all crossings within the Phyllis Canal, Highline Canal, Lowline Canal, and all other facilities and locations deemed necessary by the **PID** Board. Sleeves under open channels shall be smooth steel casing with 3/8-inch minimum wall thickness. Sleeves under piped portions of laterals and drains shall be smooth steel casing with 3/8-inch minimum wall thickness, Class 200 PVC C900 or C905, or High-Density Polyethylene (HPDE) with a minimum wall thickness matching an equally sized PVC sleeve.

Underground utility crossings outside of road right-of-way improvements shall cross below **PID** operated and maintained facilities and shall have 5 feet minimum cover from flowline of supply facilities (canals and laterals) to the top outside edge of sleeve and 10 feet minimum cover from flowline of drain crossings to the top outside edge of sleeve.

Underground utility crossings within road rights-of-way shall cross below **PID** operated and maintained facilities and shall have 3 feet minimum separation from the bottom of the **PID** facility (pipe or box culvert) to the top of the crossing sleeve or utility.

Fiberglass reinforced composite utility marking posts shall be placed in line with all open channel underground utility crossings of supply facilities at the outside edge of the facility easement. Marking posts shall be labeled “CAUTION BURIED [utility]”.

Bollards shall be placed in line with all open channel underground utility drain crossings at the outside edge of the facility easement. Bollards shall be constructed of 8-inch diameter 3/8-inch steel pipe filled with concrete and shall be placed in a concrete foundation a minimum of 2 feet in diameter and 2-1/2 feet deep. Bollards shall extend 4 feet above finished grade and 2 feet into concrete foundation. A sign shall be affixed to each bollard stating “CAUTION: BURIED [utility]”.

A **PID** licensing agreement is required for all underground utility crossings.

1203.02.02 Underground Utility Crossings (Live Crossings) During Irrigation Delivery Season

Utility crossings of **PID** facilities during irrigation delivery season are undesirable and generally not acceptable. Live crossings completed by a Utility Company for emergency purposes only (i.e. without power, gas, communications...) may be considered by the **PID** Board on a case by case basis.

PIONEER IRRIGATION DISTRICT STANDARDS AND SPECIFICATIONS

The Utility Company shall apply for the crossing using the Land Use Change/Encroachment Application so that each live crossing receives **PID** Board consideration.

The Utility Company shall provide the name of the directional drilling contractor completing the bore. Said contractor shall have competent bore operators to complete the work. The Utility Company shall also provide a hazard analysis identifying all perceived hazards of the bore project and submit for **PID** review. The hazard analysis should include potential for **PID** facility failure, damage to other utility crossings, as well as any other hazards and planned procedures to prevent identified hazards.

Utility crossing design must be reviewed by **PID**'s engineering firm. Prior to engineering review, the Utility Company shall agree to pay any additional review costs beyond the standard utility fee. The Utility Company should be made aware additional review costs may be incurred even if the project is ultimately not feasible during the irrigation season.

If the Utility Company's plan and supplemental information satisfies the Board, **PID** will permit an approved crossing through its Utility Crossing Agreement.

The crossing shall be placed under public roadway improvements within road right-of-way and be bored and sleeved. Live crossings will only be considered in locations where the **PID** facility is tiled (i.e. 4-sided box culvert and piped locations).

Live bore sleeves should be a maximum of 4-inches in diameter, be a minimum of 15 feet below the bottom of the canal, a minimum of 25 feet outside of the **PID** easement on each side of the facility.

The length and depth of the bore should be determined based upon topography and geographical conditions as well as the condition of the facility. All utility crossings of live facilities will be site specific. For example, large elevation changes or known rock outcroppings near the facility may negate live crossing of any facility. Boring should be completed from existing road surface.

The use of bore pit may be approved by **PID** during live facility boring. Location of bore pits to be determined by Pioneer Irrigation District based upon review of facility conditions and adjacent soils. The placement of bore pits must not compromise the integrity of the irrigation facility.

Live facility crossings shall not be completed by open trench methods.

Project construction shall be monitored by a **PID** representative during the entire process. Any additional costs to the District for this monitoring should be paid for by the Utility Company.

The Utility Company's contractor shall keep a detailed log of the bore. Said log should be kept updated and include horizontal and vertical alignments of the bore. Said log shall be available for review by a **PID** representative at any time. A detailed bore report shall be delivered to **PID** upon completion of the project.

PID reserves the right, during construction observation, to stop all construction if facility integrity becomes a concern. In the event of a stop work order by **PID**, the Utility Company shall plug the bore cavity throughout its length with a pressure grout or equivalent. No additional attempts to cross the live facility will be allowed after a stop work order by **PID** is issued.

1203.03.02 Aerial Utility Crossings

All aerial utility crossings must receive approval of **PID**. **PID** will review and approve aerial utility crossings on a case by case basis, and may require a license agreement for approval.

All upgrades to existing overhead crossings shall meet Idaho Power Company minimum standards.

If approved by **PID**, new overhead crossings shall be a minimum of 18-feet of clearance spanning the entire width of the **PID** easement.

Additional separation may be required by other jurisdictions.

1203.03.03 Minor Utility Appurtenances

Above ground minor utility based appurtenances may be allowed to be placed within **PID**'s easements through a Utility Agreement. All appurtenances and the locations of said appurtenances proposed within a **PID** easement will be reviewed by **PID**'s Superintendent and/or Board on a case by case basis. Information regarding the appurtenance necessity, size, use, and location shall be provided to **PID** to enable review. Appurtenances causing a void below existing ground elevations will be denied. An excessive number of appurtenances proposed within a **PID** easement, or appurtenances interfering with **PID**'s use of its easement, may be required to be placed outside of **PID**'s easement or be exempt from using a **PID** Utility Agreement. All minor appurtenances must have the ability to be removed or secured during **PID**'s maintenance activities.

Minor utility appurtenances that may be allowed by **PID** under a Utility Agreement include power poles and guy wires (replacement only), light poles, utility location markers, traffic signs, Jersey barriers, and guard rails.

1203.03.04 Temporary Irrigation Crossings

Temporary irrigation crossings may be allowed with **PID** approval at appropriate locations. Proposed fill extents and depths shall be detailed and discussed with **PID**'s superintendent for proper consideration of any request to install a temporary crossing. Temporary crossings requiring excessive fill or any excavation within **PID** easements will not be allowed. Temporary crossings requiring a carrier pipe greater than 12- inches in diameter will require additional **PID** Board review.

Pipe proposed for a temporary irrigation crossing shall support HS- 25 loading with the manufacturer's minimum recommended cover. The Applicant shall furnish pipe manufacturer's specifications and/or loading calculations to provide the District with reasonable assurance the HS- 25 and conveyance loading can be supported. Pipe must be in good quality condition. Pipe of questionable quality due to age, ultraviolet damage, oxidization, lack of documentation, or other issues suggesting questionable pipe integrity will not be allowed within temporary crossings.

Approved temporary irrigation crossings shall not be constructed until a licensing agreement has been executed by the Applicant and the District. Applicant shall contact **PID**'s Superintendent for temporary irrigation crossing licensing agreement requirements. Temporary crossing construction shall be scheduled with the **PID** superintendent to prevent interference with **PID** operation and maintenance activities and must be completed between November 1st and March 1st.

1204 PIPE INSTALLATION

1204.01 General

All pipe shall be assembled and installed in accordance with the pipe manufacturer's recommendations and as shown on the project engineering plans/drawings. All gravity irrigation mains shall be installed with the bell end upstream and spigot end downstream.

Pipe joints shall be wiped clean of all dirt, grease, and foreign matter. When work is halted, all open ends of the installed pipe shall be sealed to prevent material from entering the pipe.

Field cut pipe ends shall be beveled to match factory-finished beveled pipe ends. Reinforced Concrete Pipe (RCP) joints shall be in accordance with ASTM C 443, Rubber Gasketed Joints. Installed RCP pipe joints shall meet the maximum allowable joint gap requirements per the pipe manufacturer.

When assembling gasketed PVC pipe, clean and inspect gaskets, pipe bells, and spigots thoroughly. Use only lubricant furnished or specified by the pipe manufacturer and apply as specified by the manufacturer.

Provide bentonite cut off walls at pipe ends and on each side of concrete structures, to decrease water migration into pipe bedding. Only required on delivery facility piping unless otherwise required by Pioneer Irrigation District.

1204.02 Pipe Installation--OUTSIDE Street Rights-of-Way

All work outside street rights-of-way shall meet both these specifications and the current *ISPWC* specifications including:

1204.02.01 Excavation

Utilities encountered within the pipe zone shall be relocated below the pipe zone. Topsoil shall be stockpiled and used for the top layer during backfill. New utility crossings shall cross below **PID** facilities. For the purposes of this standard, the pipe zone shall be defined as any area within 12 inches of the outside edge or bell of the pipe.

A minimum of 36 inches of clearance between outside bell of pipe and the utility shall be maintained. Clearances less than 36 inches shall be reviewed by the **PID** Board and approved on a case by case basis.

1204.02.02 Pipe Bedding Material

Pipe bedding and zone material shall be included in the full width of the trench from four (4) inches below the bottom of the pipe to six (6) inches above the top of the pipe.

Pipe bedding system shall be Class A-1 within public right-of-way, which includes Type I bedding materials in the upper and lower bedding zones, unless otherwise approved by PID. Pipe bedding system shall be Class A-2 for all areas outside of rights-of-way, which includes Type I bedding materials in the lower bedding zone and Type II or III bedding materials in the upper pipe zone unless otherwise approved by PID.

CLASS A-1 BEDDING SYSTEM

A. Place Type I Bedding 4 inches below the bottom of the pipe (6 inches for pipes, 30 inches and larger), to 6 inches above the pipe.

CLASS A-2 BEDDING SYSTEM

A. Place Type I Bedding 4 inches below the bottom of the pipe, 6 inches for pipes 30 inches and larger, to springline, then place either Type II or Type III bedding to 6 inches above the pipe.

Type I Bedding Materials

Type I pipe bedding material shall be ¾-inch 60% crushed or fractured (at least on one side) gravel or sand meeting the following gradation and in accordance with Division 300 Section 305 Part 2 of the latest edition of the I.S.P.W.C.:

Sieve Size	Percent Passing
1-inch	100
¾-inch	80-100
3/8-inch	20-70
No. 4	5-20
No. 8	0-5
No. 200	0-3

Type II Bedding Materials

Type II Aggregate Material: Use for Foundation Stabilization meeting the following gradation and as otherwise specified in Section 801 – Uncrushed Aggregates in the latest edition of the I.S.P.W.C.:

Sieve Size	Percent Passing
3-inch	100
No. 4	5-20
No. 200	0-3

Type III Bedding Materials

Sand with 100% passing the No. 4 sieve and less than 3% passing the No. 200 sieve. Pipe base material shall be placed and compacted sufficiently to preclude future settlement. Compaction of pipe zone and trench backfill material shall begin when there is sufficient cover to protect the pipe from damage. For the purposes of this standard, the pipe zone shall be defined as any area within 12 inches horizontally, 4 inches below, and 6 inches above the outside edge or bell of the pipe.

PID may require silt or bentonite backfill materials within the pipe zone to prevent water migration into the pipe bedding adjacent to headwalls and in critical open channel locations.

All bentonite backfill materials referenced throughout the **PID** Standards and Specifications for construction shall be 50% bentonite with 50% fine grained native materials. If native materials are sands and gravels, fine grained materials shall be imported from off site and be mixed to the percentages above.

1204.02.03 Trench Backfill Above Pipe Zone

Native trench material free from cinders, ashes, refuse, organic and frozen materials, cobbles or rocks not larger than six (6) inches may be used. Trench backfill above that required to protect the pipe shall be placed in two (2) lifts and compacted sufficiently to preclude settlement. Mechanical compaction and/or water settling shall be used to compact backfill. Topsoil shall then be placed, compacted and graded.

PID may require silt or bentonite backfill materials within the trench backfill above the pipe zone to prevent water migration into the pipe bedding adjacent to headwalls and in critical open channel locations.

1204.03 Pipe Installation--INSIDE Street Rights-of-Way

All work inside street rights-of-way shall meet these specifications, the specifications of the governing agency, and the current *ISPWC* specifications. If specifications differ or conflict, the more stringent specification shall govern.

1205 Concrete Structure Requirements for Gravity Systems

Unless otherwise approved by the **PID** Board, all structures shall be cast in place reinforced concrete boxes and spacing shall be a maximum of 400 feet and at all horizontal angle points and changes in pipe grade. Irrigation boxes shall be sized so that the outside diameter (O.D.) of the pipe is a minimum of 6-inches clear from the nearest inside corner of the concrete structure.

Pipes shall be installed flush with the inside concrete wall. Structures shall be constructed without sumps. However, Pioneer reserves the right to require sumps on a case by case basis as necessary based on facility location and function. Waterstop shall be installed at all cold joints. Waterstop in floor/wall cold joints shall be 6-inch wide ribbed centerbulb PVC waterstop or a hydrophilic strip bentonite based waterstop Cetco RX102 for walls up to 6-inch thick and Cetco RX 101 for walls 8-inches and larger. Rubber Pipe gaskets shall be placed around all pipe penetrations prior to concrete placement. Alternative methods of installing waterstop around pipe penetrations may be allowed on a case by case basis, to be determined by **PID**. Structure top shall be a minimum of 1-foot above and a maximum of 4-feet above finished grade. Polypropylene coated manhole steps may be required and, if required, shall be installed on the upstream side of the gravity irrigation structures.

1205.01 Inlet and Outlet Structures

Inlet and outlet structures shall be designed so that the upstream hydraulic grade line remains the same or is reduced at full flow. **PID** reserves the right to require vent piping near gravity irrigation structures. Vent piping will be considered on a case-by- case basis. Structures shall be concrete in accordance with Division 700 of the latest edition of the *ISPWC*.

Inlet and outlet structures shall be constructed with wing walls extending 1-foot minimum into the canal bank at the high water elevation. Top of structures shall be 1-foot minimum above the high water elevation. The top of the tapered wing walls shall be 4-inches below top of bank in areas adjacent to irrigation facility access roads.

PID's Board may, on a case by case basis, require the wing walls be extended from the structure to the catch point of the slope, a minimum of 1-foot above high water elevation, in areas of substantial slope.

All joints shall be watertight and backfill shall be compacted to 95% of standard proctor as determined by ASHTO T99 Method A. Compaction effort shall meet the requirements of ISPWC Division 200 Section 202 Class A Compaction. Soil backfill material shall meet the requirements of ISPWC Division 200 Section 203 – Soil Materials Subsoil Types S3 or S4. Preferably S4 if it is available on-site. Material shall be placed and compacted in 6-inch lifts.

See **PID** Standard Drawing No. P-1209.

1205.02 Concrete Liner

Concrete liners shall be placed on any commercial or residential development adjacent to and below a **PID** facility within high fill areas, **PID** Board approved realignment of **PID**'s open channel supply facilities, and may be required by **PID** in order to approve modification to or grading changes adjacent to **PID** supply facilities in areas of concern as determined by the Board.

Concrete liners shall be a minimum of 4-inches thick and shall at a minimum match existing channel dimensions. Side slopes shall not exceed 2:1 and liners shall extend a minimum of 1-foot above the high water elevation or to the top of bank. The concrete mix shall have a final minimum strength of 3,000 psi. Reinforcing fibers shall be added to the concrete mix at a minimum rate of 1.5 pounds per cubic yard of concrete. The individual fibers shall be 1/2 inch to 3/4 inch in length and shall be blended into the concrete mix according to the manufacturer's specifications.

Control joints shall be 1/4" wide perpendicular to the centerline of the concrete lining, at a depth equal to one-third of the lining thickness with a uniform spacing not to exceed 12 feet. Construction joints shall be the butt type, formed square with the lining surface and at right angles to the **PID** facility. Control and construction joints shall have smooth finishes.

AquaLastic®, AquaSeal™, or an approved equal shall be applied to all expansion joints to a minimum of 1 foot above high water elevation. Areas to be coated or sealed shall be sandblasted and cleaned in accordance with manufacturer's recommendations prior to applying coating.

Waterstop at cold joints and waterproofing products such as AquaLastic®, AquaSeal™, Xypex®, or approved equivalents may be required to seal the concrete liner as determined by the **PID** Board on a case by case basis.

Polypropylene coated manhole steps shall be installed in the concrete liner to create exit areas. Exit areas shall be a maximum of 400 feet apart. Manhole steps shall be firmly embedded and shall withstand ASTM C-497 pullout testing. Steps shall be aligned vertically and spaced 12-inches vertically on center. Manhole steps shall be placed no greater than 16 inches from bottom of liner and no greater than 24 inches from top of liner.

1206 Bridges/Crossings

The location and size of all bridges and box culverts, both new and replacement, shall be approved by the Board. All bridges and crossings that may accommodate vehicular traffic shall accommodate HS-25 loading.

Private bridge crossing locations, intended use, and design shall be reviewed and approved by the **PID** Board on a case by case basis. Pedestrian/other bridges shall meet local government requirements based on nature of use.

1206.01 Structures

Bridges and box culverts shall meet the following general requirements: (a) Span shall be from top of bank to top of bank without center supports.

(b) A 1-foot minimum clearance between high water and the lowest appurtenances of crossing shall be maintained.

(c) Maintenance shall be by the party operating said crossing and they shall execute the required **PID** licensing agreement.

(d) Improvement plans for bridges shall be designed by a structural engineer and bridges supporting vehicular traffic shall accommodate HS-25 loading.

1207 Control Structures

1207.01 Weirs

Weirs shall be placed on all new or modified delivery locations unless water surface elevation head differences are inadequate for the weir to operate properly. Weirs shall be placed in a weir box with engineered scale depth gauge. See detail P-1211.

Weirs shall be owned and operated by **PID**, and weir easements shall be granted to **PID** for all weir structures.

1207.02 Checks

Checks utilizing 2-inch wide 1-1/2-inch deep notches into the concrete check structure wall shall be placed in all control structures less than 60-inches in width.

Checks utilizing 3-1/2 inches wide 2-inch deep notches into the concrete check structure wall shall be placed in all control structures 60 inches or greater in width.

Check notch location shall be determined by flow rate and size of structure. Check notches shall be located a minimum of 12 inches from the downstream check structure wall.

Bolts for necessary check rails shall be cast in place or shall not be installed via drilling and Redhead or expandable bolts or lags until the recommended cure period for the concrete mix design.

1207.03 Gates

Waterman C-10 canal gates or approved equal shall be used. Gates shall be installed in accordance with manufacturer's requirements. Canal gate wheel height shall be a minimum of 2-7/8 inches above structure and a maximum of 6 inches above structure.

Bolts to attached gates shall be cast in place or shall not be installed via drilling and Redhead or expandable bolts or lags until the recommended cure period for the concrete mix design.

Slide gates are not acceptable.

1208 Final Observation & Testing Prior to Warranty Period

1208.01 Polyvinyl Chloride (PVC) Pipe

PVC pipe shall be tested in accordance with ISPWC Division 500 Section 501 Part 3.4. Testing is required for PVC piping that is to be owned, operated, and maintained by **PID**. Governing agency requirements shall be met when crossing rights-of-way and easements. Final pressure testing shall be conducted after all utility installation is completed and before any asphalt is placed. Final acceptance and warranty period will not occur or commence prior to a passing pressure test.

1208.02 Reinforced Concrete Pipe and Poly-coated Corrugated Aluminized Steel Pipe

RCP and poly-coated CSP piping that is to be owned, operated, and maintained by **PID** shall be visually inspected by **PID** personnel and/or its engineer after all utility installation is complete and before any asphalt is placed. Any defects found during inspection shall be corrected and re-inspected. Gasketed RCP shall be pressure tested in the presence of the Engineer in accordance with ISPWC Division 500 Section 3.4. Final acceptance and warranty period will not occur or commence prior to a passing inspection and pressure test.

1209 Street Crossing Requirements

Street crossings shall be placed no closer than 200 feet from the nearest edge of any street crossing to nearest edge of another street crossing.

Concrete structures are to be placed outside of, and on both sides of, the right-of-way or ingress/egress easements. Structures shall conform to the *Concrete Structure Requirements For Gravity Systems*.

A minimum 12-foot wide, 20-foot long access road shall be constructed from the street crossing to the irrigation facility easements on **all** sides of street crossing for **PID** access. Said access roads shall be a minimum of 8-inch depth of ¾" minus road mix from back of walk or paved surface to existing grade at the irrigation facility. Access road approach slopes shall not exceed 5%. Concrete driveway approaches or rolled curbs shall be constructed where **PID** access roads and vertical curb street crossings intersect to facilitate access.

See **PID** Standard Drawings No. P-1213 (Driveway Approach) and P-1214 (Rolled Curb).

1210 Structure Lids

Structure lids in rights-of-way or ingress and egress easements shall be HS-25 wheel load rated. Structure lids outside of rights-of-way and ingress/egress easements shall be designed to withstand a 300 lb point load with a maximum allowable deflection of ½ inch at center span and in accordance with the International Building Code. Lids exceeding a 6-foot span shall be engineered. Lids shall be expanded metal and provide access to control structures inside the box via hinged access ports. Lids shall be bolted in place with a minimum of 4 (four) bolts with the access port to allow unobstructed access to the downstream side of the structure without bolt removal. Lids shall have a chain ring near canal gates to secure gates with a chain. Bolts and chain rings shall be cast in place. Alternative methods of installing bolts, such as drilling, placement of Redhead or expandable bolts, may be allowed on a case by case basis, to be determined by **PID**. Alternative methods shall not be performed on concrete structures prior to the completed cure period for the concrete mix design. Canal gates shall be accessible without opening lid. All lids shall have a locking mechanism

approved by **PID**.

See **PID** Standard Drawing No. P-1210.

1211 Method of Measurement and Basis of Payment (For PID Projects)

The following items shall constitute pay items for the work covered under this section of the specifications. Payment for these items shall be full compensation for providing all materials, tools, labor and equipment necessary to complete the item and all incidental work related thereto, whether specifically mentioned herein or not:

1211.01 Gravity Mains

Measurements of irrigation mains shall be made in lineal feet along the centerline of pipe through all boxes, control structures and appurtenances. Payment for gravity irrigation mains will be made at the contract unit price bid per lineal foot of the various sizes called for, which price shall include excavation and backfill and furnishing and installing pipe, fittings, boxes, control structures and headgates; cleaning and testing the pipe and all other work necessary or incidental for completion of the item as shown on the approved plans, unless otherwise specified in the "Special Provisions." Payment will be made under:

1309.01.01 ____ "Gravity Irrigation Main, Class_....Lineal Foot

1300 ADDITIONAL REQUIREMENTS

1301 Construction Deadlines

1301.01 Construction Dates

All construction/installation within **PID's** easements shall be completed between November 1st and March 1st of the following year. Once the deadline of March 1st arrives, all construction projects must be completed and no further projects may begin until the next November 1st.

A construction schedule shall be provided to **PID** at the pre-construction meeting. If **PID** has additional input to minimize impacts to existing facilities, the developer/landowner and contractor shall implement **PID's** input.

1301.02 Construction Postponement

PID reserves the right to postpone or halt construction on a project if the March 1st deadline is not achievable, or the integrity of the **PID** facility could be jeopardized by adverse construction techniques or conditions. Any exceptions shall be approved by the **PID** Board on a case by case basis.

1302 Financial Responsibility

1302.01 Developer/Landowner Proposed Projects

PID facilities shall remain fully operational and in place during realignment project construction with minor modifications. Minor modifications shall include, but are not limited to, ditch restoration, including minor backfill, removal of backfill, or shaping of the existing facility. Structure removal, headgate installation, and structure construction, among other construction activities, are not minor

modifications. Due to adverse site conditions, along with other matters, the **PID** Board may determine no modifications are acceptable within **PID** easements until all improvement construction outside of **PID** easements has been constructed and approved by **PID**.

Upon final **PID** approval of the realignment construction, the existing facility may be abandoned and removed. If the realignment project is not completed to **PID**'s satisfaction, the property developer/landowner shall remove obstructions to and restore the original facility. If the developer/landowner fails to remove obstructions, and restore the original facility, **PID** may, after providing prior written notice to the developer/landowner, either perform the removal and restoration work or cause it to be performed and the developer/landowner will be billed for **PID** costs.

If it is necessary to build within the existing facility, thus rendering the facility inoperable with approved minor modifications, the property developer/landowner shall submit a cost estimate for the project to **PID**'s engineer. **PID**'s engineer will confirm the validity of submitted costs. The developer/landowner shall provide five percent (5%) of the confirmed project costs, to be deposited with **PID** in the form of a cashier's check payable to **PID**, at the time of execution of the applicable license agreement by the developer/landowner. **PID** shall refund this deposit if the construction is completed by March 1st, and in accordance with the terms of the agreement.

In the event the developer/landowner fails to complete the **PID** improvements, or in the opinion of **PID**'s Board or superintendent and **PID**'s engineer, cannot complete the project as set forth herein by March 1st, **PID** may, after providing prior written notice to the developer/landowner, either complete the project or cause it to be completed. In taking such action, **PID** may charge against the five percent (5%) deposit reasonable costs, including inspections, tests, or retests (whereby test results of the materials to be used and/or installed are shown not to conform to approved project specifications), liquidated damages, costs of litigation and reasonable attorney fees, which shall include paralegal fees and appellate fees. Developer/landowner shall be liable for any expenses incurred over and above the amount of the deposit.

If construction is not completed by March 1st in a manner which allows for the adequate delivery of water, the developer/landowner will pay non-refundable liquidated damages of two hundred dollars (\$200) per day until construction is completed and approved by **PID**. **PID** may, after providing prior written notice to the developer/landowner, intervene and either complete the project or cause it to be completed to ensure adequate delivery of water to patrons if it deems necessary. Developer/landowner may be required to forfeit the five percent (5%) deposit outlined above to **PID** if **PID** intervenes. Remedial work will be performed at the sole convenience and discretion of **PID**. **PID** will use the deposit to offset costs incurred by **PID**. The developer/landowner shall pay all additional costs not covered by the deposit to complete corrective work. Any unused deposit will be refunded to the developer/landowner.

1302.02 Bonding for PID Contracted Projects

If the project improvements are to be completed on behalf of **PID**, the contractor completing construction for **PID** shall furnish **PID** with a cash deposit or a one-year irrevocable letter of credit, with a one-year automatic renewal clause (hereinafter identified as "Instrument"). The amount of the Instrument shall be 110% of the estimated cost of any improvements associated with the irrigation system, to be constructed. The Instrument shall have an effective minimum term of one-year and, further shall ensure performance of the contractor's obligation(s) as designated on the approved plans. The Instrument shall only be issued by a financial institution authorized to do business in the State of Idaho.

In the event the contractor fails to complete the **PID** improvements, or in the opinion of **PID**'s Board or superintendent and **PID**'s engineer, cannot complete the project as set forth herein by March 1st, **PID** may, after providing prior written notice to the contractor, either complete the project or cause it to be completed. In taking such action, **PID** may charge against the Instrument reasonable costs, including inspections, tests, or retests (whereby test results of the materials to be used and/or installed are shown not to conform to approved project specifications), liquidated damages of two hundred dollars (\$200) per day until construction is complete, costs of litigation and reasonable attorney fees, which shall include paralegal fees and appellate fees. Contractor shall be liable for any expenses incurred over and above the amount of the Instrument.

1303 Request Deadlines

To allow adequate time for project review, licensing and construction completion, requests for crossings that interfere with the function of a Pioneer Irrigation District facility, or for relocations or piping of any segment of Pioneer Irrigation District's irrigation system, shall be submitted on or before **November 15th**, unless otherwise provided herein, for construction activities to be considered which will be completed prior to March 1st of the following year. Pioneer Irrigation District reserves the ability to require projects to be postponed if adequate construction timing appears to be unachievable by March 1.

1304 Delivery Point

PID will designate a site within the proposed subdivision plat, short plat subdivision, lot, tract, parcel or site for water delivery into the new system.

Where **PID** delivery facilities exist on the property being divided, piping shall be designed for delivery from that point unless otherwise designated by **PID**.

Where **PID** facilities do not exist on the property being divided, **PID** will designate the delivery point based on proximity to **PID** facilities, and efficiency and accuracy of delivery over a Cipolletti weir.

Connection of a pressure irrigation system to **PID** facilities shall include a continuous gravity overflow to prevent water level fluctuation within the **PID** delivery ditch/pipe in the event of pump station shutdown or failure.

Projects connecting to a new or existing pressure or gravity irrigation system must obtain irrigation water from the original supply facility or obtain **PID** Board approval to deviate from the original delivery point. Verification that the subject property is within **PID** boundaries shall be made prior to design and construction of the irrigation system. Water supplied by **PID** shall not be used on property outside of **PID** boundaries. Projects removing an existing delivery point shall provide written agreement of the downstream water users to connect to a municipal or private facility that obtains irrigation water from a **PID** supply facility as stated above. If the downstream water users will not provide an agreement the existing delivery point shall remain in place and functioning.

1305 Contractor Licensing

All Contractors working on or installing irrigation facilities shall hold and be currently licensed as Public Works Contractors in the State of Idaho. Contractors shall be licensed to perform the type of construction involved to construct gravity irrigation systems.

1306

Plan Submittal and Review

Any and all proposed modifications, changes, removal or addition to any structure, equipment, piping, component, facility, canal, ditch, lateral, or any other conveyance facility owned, operated, or maintained by the **PID** shall be designed by an engineer licensed in the State of Idaho and plans and specifications shall be submitted to the District for review by the District's engineer. After the design engineer adequately addresses all District engineering comments, the District engineer will recommend approval of the improvement drawings. Final improvement drawing approval is subject to the approval of **PID's** superintendent.

Submittals must include the current Land Use Change/Encroachment Application on file with **PID** (an example of which is found on Page 30 of this publication). The developer/landowner must fill out the top portion of the form as indicated, and must include the following:

- A vicinity map of the project and detailed plans and specifications for the entire project, including the encroachment
- Legal Description that encompasses all property affected by project
- Warranty Deed for property involved in project
- A short written description of the proposed encroachment into **PID's** facilities
- Administrative, engineering, and legal fees

Incomplete submittals are **not acceptable for review** and will be rejected, and the applicant will be notified in the case of incomplete submittals. Electronic submittals are acceptable for review, however once plans are approved the applicant shall provide **PID** two (2) hard copies of the approved plans.

Review and approval by **PID** does not constitute an engineering review of project plans, specifications, or calculations. The sole purpose of the review is to ensure general conformance with **PID** policies, standards and requirements. The design engineer is solely responsible for the design including all project plans, specifications, or calculations. All submittals shall be stamped and signed by a Professional Engineer registered in the State of Idaho. All plan review submittals for subdivision projects shall include a final plat and all projects shall include a complete set of plans.

Upon approval of the final design, **PID** shall be provided electronic files of the approved design.

To compensate **PID** for its costs and expenses in reviewing proposed development plans, a Review Fee will be charged. Plan Review Fees are due in full when plans are submitted with the Land Use Change/Encroachment Application to **PID** for review and unused fees will be refunded. Continuing progress or delivery of license agreements may cease, if payments are not received.

Upon receiving engineering plan approval, the developer/landowner shall execute a **PID** licensing agreement for any proposed construction modifying or impacting **PID's** facilities or property interest. The license agreement shall be executed and recorded before any construction activities relating to **PID** facilities begin, unless **PID** authorizes otherwise on a case by case basis.

Prior to finalizing the licensing agreement **PID** will require verification that any project crossing, modifying, altering, encroaching, encumbering, utilizing, or boring within **PID's** easement has received a Section 404-Permit as required by the Clean Water Act from the United States Army Corps of Engineers. A non-jurisdictional waiver letter will be required if a 404-Permit is deemed unnecessary by the Army Corps of Engineers. Electronic correspondence of the 404-Permit or non-jurisdictional waiver letter from the United States Army Corps of Engineers is acceptable.

The project developer/landowner shall be responsible for reimbursing **PID** for the costs incurred negotiating, preparing, and executing the required licensing agreement. Continuing progress or delivery of license agreements may cease, if payments are not received.

1307 Construction Observation

The contractor's surveyor shall verify the existing flowline, top of bank, and toe of slope match the approved plans both horizontally and vertically prior to construction staking. If discrepancies are found construction may not commence until the improvement drawings have been revised and reviewed and approved by **PID** and its engineer, and an addendum to the licensing agreement has been recorded. Any deviation from this requirement shall require **PID** Board approval on a case by case basis.

The Contractor installing the facilities shall notify a designated **PID** observer two (2) working days prior to beginning any work.

All trenches shall be left open for observation. Compaction testing shall be in accordance with ISPWC Division 300 Section 306 Part 3.3. Testing is required for all gravity piping that is to be maintained by **PID**, including that to be located under private parking lots or private access roads. **PID's** engineer is required to observe all compaction testing, pressure testing, structures and trenches. A minimum of 48-hours advance notice to **PID's** engineer is required.

All costs and expenses incurred by **PID** for construction observation by their engineering consultant are the developer/landowner's responsibility and shall be promptly paid to **PID** upon invoicing.

PID's engineering consultant will perform construction observation services for **PID**. To compensate **PID** for costs and expenses to observe construction, a construction observation fee will be charged. The Construction Observation Review Fees are due in full prior to construction commencement and are non-refundable.

1307.01 Close Circuit Television (CCTV) Inspection

Prior to requesting a final walkthrough with **PID** representatives, the developer/landowner shall have all pipes smaller than 36 inches in diameter CCTV inspected. **PID's** engineer shall be notified prior to the CCTV inspection and may choose to observe said inspection. Two DVDs and reports of the CCTV inspection shall be provided to **PID's** engineer for review prior to final acceptance.

1308 Final Acceptance

1308.01 Punch list Requests

Upon completion of construction of any relocated, modified, or piped facilities by **PID**, the developer/landowner shall request a walkthrough with the **PID** Superintendent or his designee. Upon completion of said walkthrough, **PID** will forward a copy of a punch list documenting outstanding items. Upon developer/landowner completion of all punch list items, the developer/landowner shall request a final walkthrough with the **PID** superintendent in writing.

1308.02 Dedication Requests

Upon final walkthrough with **PID**, **PID** shall notify developer/landowner regarding status of the punch list. If all punch list items are completed to **PID's** satisfaction, developer/landowner shall request, in writing to **PID** that **PID** accept said system. Upon acceptance by **PID**, the **PID** Board

or Superintendent shall notify the developer/landowner in writing. The date of said written acceptance shall become the effective commencement date of all applicable warranty periods.

1309 Pavement Removal and Restoration

1309.01 Removal of Pavement

Neatly cut all bituminous and concrete pavement, regardless of the thickness, prior to excavation of the trenches, with an approved pavement saw or cutter. Pavement cuts shall be made a minimum of twelve (12) inches away from any disturbed sub base.

1309.02 Asphalt Concrete

Asphalt concrete used in conjunction with a project shall be furnished and placed in accordance with the current edition of the *ISPWC*.

1309.03 Pavement Construction

The pavement shall be cut to provide clean, solid, vertical joints. Whenever possible, cut lines shall be parallel to or at right angles to the street centerline.

Immediately before applying the tack coat, the surface to be treated shall be swept clean of all loose material, dirt, excess dust or other objectionable material. Tack coat application is prohibited when the surface is appreciably damp or when weather conditions are unsuitable.

Following preparation of the base course and abutting edges, the contractor shall apply CSS-1 emulsified asphalt (tack coat) to all joined surfaces. Asphaltic concrete shall be placed to a minimum compaction depth of two (2) inches, or be placed in accordance with governing agency requirements whichever is more stringent. Contractor shall provide a smooth, even surface conforming to adjacent surfaces.

1310 Easement Requirements

All **PID** easements shall be kept unobstructed at all times. Easements for all **PID** owned, operated, or maintained canals, laterals, drains, concrete structures and weir structures shall appear on the subdivision plat (if platted). Metes and bounds easement descriptions shall be provided when subdivision platting does not occur. The easement widths shall be determined on a case-by-case basis by **PID** in accordance with Idaho Code Section 42-1102, and cognizant of the legal duties owed by **PID** under Idaho Code Title 42, Chapter 12. Easement widths in high fill areas may require sixteen (16) feet from the toe of fill slope outward in addition to the typical easement widths. Easements for **PID** facilities shall be exclusive of adjacent rights-of-way and shall not be reduced in width.

In general, **PID** drain easements measure/extend: Fifty-five (55) feet from centerline and Twenty-five (25) feet minimum from inside top of bank in each direction.

In general, piped **PID** facility easements measure/extend:

- 10 feet from pipe centerline on both sides (20 feet overall) for pipes up to and including 24-inch diameter.
- 15 feet from pipe centerline on both sides (30 feet overall) for pipes greater than 24-inch diameter up to and including 48-inch diameter.

PIONEER IRRIGATION DISTRICT STANDARDS AND SPECIFICATIONS

- **PID** Board review is required to determine easement width on pipe larger than 48-inch diameter.

Concrete structures, including weir structures, within piped facilities shall include an easement measuring a minimum of 10 feet around the perimeter of the structure in all directions. Easements shall taper to the existing easement for the open channel upstream of the inlet structure and downstream of the outlet structure. Additional easement width may be necessary as determined by the **PID** on a case by case basis based upon **PID** operation and maintenance practices. This includes consideration of **PID** equipment turnarounds and **PID** vehicular movements to and through the development and around structures.

No fences, gates, structures, or other objects/materials are allowed within a **PID** easement without the proper licensing agreement in place.

The following language shall be included as necessary on final plats impacting **PID** owned, operated, or maintained irrigation facilities (including drains):

1. For those lots impacted by a 10' or 5' blanket easement, any Pioneer easement area must be called out separately from the blanket easement.
2. For the common lots impacted by a blanket easement, any Pioneer easement area within a common lot must be called out separately from the blanket easement.
3. The **PID** easement must be expressly identified, both graphically and via a plat note, which also contains the following language or equivalent:

“Lot _____ of Block _____ contains a _____’ wide easement, in favor of Pioneer Irrigation District, for purposes of access, operation, maintenance and replacement of the _____ [canal, lateral, or drain name]. Said easement shall remain free of all obstructions, including, without limitation, fences, pathways, landscaping, and other improvements, unless specifically approved by Pioneer Irrigation District, or its successors, in writing. Said easement is further subject to the terms, conditions, and restrictions set forth in the License Agreement for [subdivision or project name], Instrument #, records of Canyon County, Idaho.”

Abandonment of Easements.

Though Pioneer owns some facilities (or portions of facilities) in fee simple, the majority of Pioneer’s canals, laterals, ditches and drains are easement based by express agreement, statute (e.g., Idaho Code Sections 42-1102 and 42-1204), and/or prescription. When Pioneer facilities are piped and/or relocated in accordance with Idaho Code Section 42-1207, Pioneer’s recorded license agreement for the project, combined with its final written approval and acceptance of the facility upon post-construction inspection, serves as an affirmative act of abandonment of the former section of ditch and its corresponding irrigation easement/right-of-way.

Under no circumstances shall the former/existing section of ditch or its corresponding irrigation easement/right-of-way be obliterated, altered, or abandoned prior to the recording of the applicable license agreement for the project, or prior to Pioneer’s final inspection and written approval and acceptance of the relocated facility.

Where appropriate and to the extent reasonably possible, Pioneer will accommodate landowner/licensee requests to prepare and record additional express ditch and easement abandonment documents provided that the landowner/licensee agrees to bear the costs and expenses

thereof.

1311 Fencing Recommendations for New Developments

All **PID** easements corresponding to open channel irrigation facilities (including drains) are recommended to be fenced. The fence shall be chain link, a minimum 4- foot high, and be placed on the boundary line of the easement along all open irrigation canals, laterals, and drains. Said fencing shall be owned and maintained by the property owner(s) adjacent to the **PID** easement.

1312 Professional Engineer Requirement

Any short plat, plat or subdivision shall have an irrigation system designed and stamped by a professional engineer licensed in the State of Idaho.

1313 Record Drawings

Record drawings detailing the entire irrigation system, including but not limited to, air and vacuum valves, and gravity irrigation structure top elevations and invert elevations, shall be prepared and provided by the engineer of record to **PID's** engineer. The engineer of record shall submit one (1) hard copy set and electronic copies of the record drawings for review. **PID's** engineer will forward electronic drawings to the **PID** superintendent upon approval of the record drawings. Record drawings shall be clean, neat, and legible, and hard copies shall be provided on 4-mil mylar reproducible copy.

1314 Construction Warranty

The developer/landowner shall warranty all work for a minimum of 3 years as outlined in the license agreement from the date **PID** issues written acceptance.

Facility repairs or changes required during the warranty period, which in the opinion of **PID** is rendered necessary as the result of the use of material, equipment, or workmanship, which is inferior, defective, or not in accordance with the terms of the contract or licensing agreement, the developer/landowner shall promptly make the required facility repairs or changes, upon receipt of written notice from, and without expense to **PID**:

1. Correct, repair, and cure all facility defects including facility replacement if necessary; and
2. Correct, repair, and cure all damage to any building, structure, site, equipment or contents thereof, which in the opinion of **PID** is a result of the noted defective condition(s); and
3. Restore and mitigate for any site-related disturbance including any property damage, stemming from all warranty-based repair and replacement activities.
4. The 3-year warranty period shall begin again after **PID** acceptance of the corrective work.

Should the developer/landowner fail to correct defects within 10 calendar days of receipt of written notice from **PID**, **PID** may correct the defects and the developer/landowner shall be liable for the reasonable costs and expenses incurred; provided, however, that in case of emergency where, in the opinion of **PID**, delay would cause serious loss or damage, repairs may be made without notice being given to the developer/landowner and developer/landowner shall reimburse **PID** for the reasonable costs of the emergency repairs undertaken by **PID**.

1315 License Agreement

For any development or activity proposing any improvements impacting a **PID** owned, operated, or maintained facility, or otherwise encroaching upon a facility easement, preparation of a license agreement is necessary prior to commencement of construction to satisfy the prior written permission requirements of Idaho Code Section 42-1207 and 42-1209. The agreement shall be executed by **PID** and the developer/landowner, and any other party deemed necessary by **PID**.

For those projects which involve the utility crossing of a **PID** facility by a utility entity or municipality, a separate license agreement will be required for such purpose. The utility license agreements will be referenced in the agreement to be entered into by **PID** and developer/landowner. Because **PID** generally does not benefit from changes to its facilities requested by developers, landowners, or other entities, **PID** requires the payment/reimbursement of all attorneys' fees and costs, including paralegal fees, incurred for the negotiation, preparation, and execution of all agreements prepared for the project, including any related agreements with utilities or other entities.

Pursuant to Idaho Code Section 42-1207, and unless expressly provided otherwise in a license agreement, the developer/landowner remains responsible for the ultimate costs of any pipeline/culvert replacement when **PID**, in its sole discretion, deems such replacement necessary

1316 Landscaping and Improvement Restrictions

Landscaping, such as low shrubs and/or grasses which do not exceed two (2) feet in height at maturity and which in no way restrict **PID's** access to and use of its facilities, easements, service roads, and paths, may be allowed as determined by **PID**. Improvements such as fences, curb, gutter, and sidewalks within **PID's** easements may also be allowed as determined by **PID**, as long as such improvements in no way restrict **PID's** access to or unreasonably interfere with **PID's** use of its facilities, easements, service roads, and paths. Any pressure irrigation sprinklers requested to be within **PID's** easement shall be located on the approved plans and shall be placed outside of the pipe zone extended to the surface. Pressure irrigation for the purpose of watering landscaping, is not allowed unless otherwise permitted separately in the license agreement. For this specification the pipe zone shall mean 12 inches beyond the outside edge of the pipe or pipe bell each way. In addition, sprinklers shall not be operated in such a way as to over-saturate the above described area or the **PID** access road. **PID** may deny sprinkler locations based on facility operation and terrain. All such improvements shall be described and detailed by the developer/landowner and specifically described and authorized in the licensing agreement.

No other improvements, such as, but not limited to, fences, structures, statues, boulders, rocks, concrete, asphalt, pathways, monuments, or any other landscaping, such as trees, shrubs, pressure irrigation lines and sprinkler heads, shall be allowed within **PID's** easements absent its prior written approval.

Absolutely no landscaping, improvements, or other objects shall be allowed within **PID's** easements for any open channel conveyance facilities owned, operated, or maintained by **PID** absent its prior written approval.

Any damage to any landscaping or improvements constructed or installed by developer/landowner resulting from **PID's** facility operation, maintenance, repair, or replacement activities shall be the sole responsibility and liability of the developer/landowner.

1317

Stormwater Discharge into District Facilities

PID does not approve, authorize, permit, allow, or accept any stormwater discharge into any facility owned, operated and/or maintained by **PID**, whether it be through a pipe, conduit, culvert, canal, lateral, drain or other ditch absent **PID**'s prior written permission in the form of license agreement specifically authorizing such discharge. Proposed stormwater discharges shall be designed so as not to exceed the pre-urban development flow rate for the proposed drainage basin (discussed below). Further, proposed stormwater discharges shall be designed to preferentially drain to drainage ditches rather than to delivery ditches as a general matter. Therefore, proposed stormwater discharges shall be designed to discharge to drainage ditches rather than to irrigation delivery ditches when: (1) the subject property historically drained to a drainage ditch prior to subdivision, or (2) when the property to be drained is adjacent to a drainage ditch and drainage can be accomplished by gravity flow.

Requests to discharge stormwater to **PID** facilities will be evaluated on a case-by- case basis. Any such requests must be accompanied by identification and delineation of the proposed stormwater drainage basin, together with an engineering stormwater report applying the following pre-urban development flow rate formula:

The Rational Method Formula is given as

$$Q = CiA$$

Where:

Q = peak runoff rate/peak discharge rate

C = Runoff Coefficient (correlates the permeability of the ground to the runoff— for calculation of pre-urban development runoff rate/peak discharge rate the applicable runoff coefficient shall be **0.20**)

i = Rainfall intensity of the design storm considered (25 year, 2 hour duration)**

** The 25-year, 2-hour duration design storm intensity shall be used for this calculation *unless* the actual pre-development *time of concentration*, as calculated by appropriate engineering methods, is longer than 2 hours in which case *the intensity associated with the actual time of concentration and the 25-year event shall be used.*

Stormwater detention systems proposing to discharge into **PID** irrigation delivery facilities *shall be oversized by 20%* of the calculated required storage volume.

All stormwater discharges to **PID** facilities must be compliant with all laws and regulations governing the same, including but not limited to the provisions of the Federal Clean Water Act and Idaho's Water Quality Standards/Rules.

PIONEER IRRIGATION DISTRICT STANDARDS AND SPECIFICATIONS

PIONEER IRRIGATION DISTRICT
PROCEDURES FOR EVALUATION OF PROPOSED ENCROACHMENTS

I.
INTRODUCTION

In order to implement the decision of the Idaho Supreme Court in the case of *Pioneer Irrigation District v. City of Caldwell*, Docket No. 37242, issued on November 14, 2012, Pioneer Irrigation District (“Pioneer”) has adopted this procedure to document the process for compliance with the requirements of Idaho Code Section 42-1209, as determined by the Idaho Supreme Court.

II.
STANDARD PROCEDURE AND EXCEPTIONS

These procedures are standard and Pioneer will strive to apply them uniformly in all circumstances where any individual or entity requests Pioneer’s written permission to install or construct an Encroachment of any nature in a Pioneer easement or right-of- way. However, if the Encroachment solely involves a project to enclose an open Pioneer ditch or canal in a pipe, or change the location of that ditch or canal, these procedures with the exception of sections III and IV below, do not apply and the procedures and standards of Idaho Code Section 42-1207 shall govern. Additionally, if a project involves a utility Encroachment, the application may be approved by Pioneer’s Superintendent. If the application is denied by the Superintendent, Pioneer’s Board of Directors will conduct a hearing on the application as provided herein. These procedures do not apply to any Encroachment involving a governmental entity which is a party to a cooperative agreement with Pioneer for evaluation of such encroachments. In such cases, the provisions of the effective cooperative agreement shall govern.

III.
WRITTEN NOTICE TO APPLICANT

Any party applying (“Applicant”) to obtain Pioneer’s written permission to install or construct a proposed encroachment in a Pioneer easement or right-of-way shall be provided with Written Notice in the form of a copy of this procedure.

IV.
APPLICATION FOR ENCROACHMENT

General Applications:

Any Applicant shall submit a completed written Land Use Change/Encroachment Application (“Application”) to Pioneer in the form of Exhibit A, hereto, along with application fees for general applications as noted below, which is intended to cover up to the first \$1,000.00 in engineering review fees, up to the first \$1,000.00 in legal fees associated with preparing agreements, and a \$300.00 nonrefundable administrative fee:

\$2,300.00 for general applications

If there are engineering fees and legal fees that are unused at the conclusion of the project, those will be returned to the applicant. Conversely, if the project engineering review fees and/or agreement preparation fees exceed the initial \$1,000.00 set aside for each, the applicant must remit the additional fees prior to Pioneer executing any agreements. Pioneer will do its best to keep the

PIONEER IRRIGATION DISTRICT STANDARDS AND SPECIFICATIONS

project fee totals to \$2,300.00 or less, but fee totals can vary depending upon the project complexity and/or construction delays.

Utility Applications:

Any Applicant for a utility crossing shall submit a completed written Land Use Change/Encroachment Application (“Application”) to Pioneer in the form of Exhibit A, hereto, along with a non-refundable application fee of \$300.00 for each project applied for.

If there are engineering fees, administration fees and/or legal fees that are incurred during the project Pioneer will invoice the applicant when they incur the expense. The applicant will have 30 days from date of invoice to pay the balance in full, if payment is not received the applicant will be charged 1.5% interest each month until payment is received. The applicant must remit the additional fees prior to Pioneer distributing or executing any agreements. Pioneer will do its best to keep the project fees low, but fee totals can vary depending upon the project complexity and/or construction delays.

As noted in Section II, above, utility Encroachment applications may be approved by Pioneer’s Superintendent. Should the Superintendent deny a utility application, the applicant is entitled to a hearing before the Pioneer Board of Directors on the matter. Utility Encroachments potentially eligible for Superintendent review and approval include, but are not necessarily limited to, gas lines, telecommunication lines, fiber optic lines, potable water, sewer, cable television, and electrical lines. The utility license agreement process may also be used to review and approve minor appurtenances associated with utilities, such as power poles (replacement poles only), light poles, traffic signs, traffic signals, utility markers, bollards, guy wires, and guard rails. All utility proposals/applications are subject to review and approval on a case-by-case basis, and may be subject to denial where the Superintendent and/or the Board of Directors determine that denial is warranted under the circumstances. All minor utility appurtenances must be designed and constructed/installed in such a manner that they are either removable or securable in order to accommodate Pioneer operation and maintenance activities.

Temporary Irrigation Pipe Crossing Applications:

Any Applicant for a temporary irrigation pipe crossing shall submit a completed written Land Use Change/Encroachment Application (“Application”) to Pioneer in the form of Exhibit A, hereto, along with a non-refundable application fee of \$100.00 for each irrigation pipe crossing applied for.

If there are engineering fees and/or legal fees that are incurred during the project Pioneer will invoice the applicant when they incur the expense. The applicant must remit the additional fees prior to Pioneer distributing or executing any agreements.

Pioneer will do its best to keep the project fees low, but fee totals can vary depending upon the project complexity.

The Application must be physically received by Pioneer by the 15th day of any month to be considered by the Pioneer Board of Directors (“Board”) at its regular monthly meeting during the following month. If the Application is not complete, as determined by Pioneer, the Applicant will be notified and requested to provide the omitted information prior to Pioneer scheduling the Application for consideration by the Board at a monthly meeting.

V.

NOTICE OF HEARING AND HEARING PROCEDURE

A. Any Applicant who has submitted an Application to Pioneer in compliance with the procedures herein, shall be mailed a written notice of a hearing before the Board, at which the Application will be considered for approval. Pioneer may appoint a hearing officer to control the conduct of the hearing if needed. At the hearing, the Applicant may present information to support approval of the Application. The Applicant is not required, but is encouraged, to attend the hearing and support the Application. The hearing will be recorded with an electronic recording device to allow for preparation of a verbatim transcript. The Board may limit the length or number of statements provided in support of the Application as necessary to provide for the orderly conduct of the hearing.

B. The Board will consider any other relevant information available to it when it considers an Application. The Board may defer making a decision on an Application until a subsequent hearing in order to conduct further investigations or obtain professional input from Pioneer's consultants, but written notice of said deferral shall be provided to the Applicant if the Applicant does not attend the initial hearing where the deferral decision is made.

C. The Board shall decide if an Application is approved or disapproved at a hearing for that purpose, but in every case, the Board shall issue a written set of factual findings and a reasoned decision which shall be in the form of a motion recorded in the official minutes of Pioneer. An Applicant shall be provided with a copy of the minutes which document the Board's decision on the Application.

D. If the Board decides to approve an Application, such approval may contain conditions and requirements which must be satisfied by the Applicant, including the requirement that a written recordable agreement must be executed and recorded before any Encroachment is installed. Pioneer deems these conditions and requirements to constitute essential protections to ensure that the Encroachment will not unreasonably or materially interfere with Pioneer's use

and enjoyment of its easements or rights-of-way. Failure to satisfy any such conditions or requirements shall void the approval of the Application, and Pioneer may remove any Encroachment installed or constructed in violation of such conditions or requirements of approval.

E. The Board intends to fairly and objectively evaluate each Proposed Encroachment to determine if it complies with the requirements of Idaho Code Section 42-1209. In its evaluation, the Board will determine if the Proposed Encroachment complies with Pioneer's specifications and standards. This determination will be a primary consideration in Pioneer's decision of whether the Proposed Encroachment unreasonably or materially interferes with the use and enjoyment of the Pioneer easement or right-of-way. Because of the unique circumstances of each Pioneer facility and the easements or rights-of-way, some decisions may differ because of Pioneer's liability risks, statutory duties, the size of a ditch or canal, the geology of the site under consideration, the surrounding land uses or properties, the water delivery requirements of downstream property owners, access needs, maintenance procedures, or operational limitations of the Pioneer facilities or interconnected facilities which may be impacted by the Encroachment under consideration. Also, Pioneer may take into account the impact of the Encroachment or Encroachments upon the entire water delivery system operated by Pioneer. Any of these considerations may be applied in Pioneer's evaluation of the Proposed Encroachment, but they are not the exclusive considerations which Pioneer may evaluate in its decision process.

(Space Above For Recorder's Use)

NOTICE OF ABANDONMENT OF EXISTING POINT OF DELIVERY FROM THE [FACILITY NAME]

The undersigned, [landowner name], represents and warrants that it is the lawful owner of the real property described in Exhibit A, attached hereto (the "Property").

[landowner name], hereby acknowledges and agrees that it is a patron of the Pioneer Irrigation District, and is entitled to delivery of irrigation water off of the [facility name] to irrigate the Property. [landowner name], further acknowledges and agrees that the relocation and underground piping of the [facility name] by [developer or other landowner], in connection with the [project description and location], will terminate its ability to divert irrigation water off of the [facility name] in its historic location. Therefore, [landowner name], hereby abandons its existing delivery point off of the [facility name]. Further, [landowner name], hereby relinquishes any and all right, title, and interest it has or may have to divert or receive irrigation water from the [facility name]. Nothing in this Notice, however, perpetually precludes the future restoration of irrigation water deliveries to the Property through substitute means, if any, provided that the restoration of irrigation water deliveries is first approved in writing by the Pioneer Irrigation District.

This Notice shall run with and burden the Property and is binding upon [landowner name], and its successors and assigns.

[LANDOWNER NAME]

BY _____
_____ (written name)
Its _____

STATE OF IDAHO)

PIONEER IRRIGATION DISTRICT STANDARDS AND SPECIFICATIONS

County of _____) ss.

On this day of _____, 20__, before me, the undersigned Notary Public in and for the said state, personally appeared _____, known or identified to me to be the _____ of [LANDOWNER NAME], the person who executed the instrument on behalf of the [LANDOWNER NAME], and acknowledged to me that [LANDOWNER NAME], executed the same.

IN WITNESS WHEREOF, I have hereunto set my hand and affixed my official seal the day and year in this certificate first above written.

NOTARY PUBLIC FOR Idaho
Residing at _____
My Commission Expires _____

EXHIBIT A
ENCROACHMENT APPLICATION

Pioneer Project Number: _____
 Date Received: _____

For Office Use Only



Pioneer Irrigation District

P.O. BOX 426 • CALDWELL, IDAHO 83606
 (208) 459-3617 www.PioneerIrrigation.com

**Land Use Change / Encroachment Application ALL
 LAND USE CHANGE APPLICATIONS ARE DUE BY
 NOVEMBER 15th**

To be completed by Applicant – incomplete applications will not be considered

Project Name:			
Applicant/Developer:			
Mailing Address:			
Contact Person:			
Phone:		Fax:	
E-Mail:			
Send Invoices To:			
Mailing Address:			
Contact Phone:		Fax:	
Contact Email:			
Design Engineer:			
Mailing Address:			
Contact Person:			
Contact Phone:		Fax:	
Contact E-Mail:			
Pioneer Specs Reviewed?	Yes	No	How Obtained?
Date of Specs?			
Required Items			
Check box to indicate inclusion with submittal, answer questions completely			
Warranty deed showing ownership of property involved (please include a copy)			
Legal Description of all property involved (please include a copy)			
Vicinity map & detailed plans/specifications for the entire project (please include a copy)			

Pioneer Irrigation District Facility	Brief Description of Impacts

Description of the land uses, structures, streets, roads, highways within 2,500 feet of the proposed /existing (choose one) encroachments (attach additional sheets if necessary):

Description of necessary and/or obtained government permits, licenses, waivers and denials (include copies if available, and describe date issued or date of denial and duration of validity):

Submitted by (please print):

Applicant Signature:

Date:

FOR PIONEER IRRIGATION DISTRICT USE ONLY

Hearing Date:	Application Number:
Application Determination	<input type="checkbox"/> Approved <input type="checkbox"/> Denied
Date:	Pioneer Rep. Signature:

Findings explaining reasons for approval or denial of application are contained in the meeting minutes of Pioneer Irrigation District Board of Directors.

PIONEER IRRIGATION DISTRICT STANDARDS AND SPECIFICATIONS

STANDARD DRAWINGS

Standard Drawings approved by **PID** are included herein and referenced by Standard Drawing number:

- P-1208 **Irrigation Check Structure.** Pioneer Irrigation District Standard Dwg. P-1208 specifies the minimums acceptable for check structures for 12-inch - 16-inch pipe. Any structure for larger pipe or larger than as shown on P-1208 shall require review by and approval of **PID**.
- P-1209 **Irrigation or Drain Inlet Structure.** Pioneer Irrigation District Standard Dwg. P-1209 specifies the minimums acceptable for inlet structures for 6-inch - 16-inch pipe. Any structure for larger pipe or larger than as shown on P-1209 shall require review by and approval of **PID**.
- P-1210 **Typical Irrigation Box Lid Detail.** Pioneer Irrigation District Standard Dwg. P-1210 specifies the materials, dimensions, general layout and construction to be used for Typical Irrigation Box Lid.
- P- 1211 **Cipolletti Weir.** Pioneer Irrigation District Standard Dwg. P-1211 specifies the minimums acceptable for Cipolletti Weir structures.
- P- 1212 **Standard Weir Box.** Pioneer Irrigation District Standard Dwg. P-1212 specifies the dimension, general layout and construction to be used for flow measurement purposes for a typical irrigation delivery with flows up to 8 cubic feet per second.
- P-1213 **Driveway Approach.** Pioneer Irrigation District Standard Dwg. P-1213 specifies the dimension, general layout and construction to be used for apron driveway approaches for a typical road crossing.
- P-1214 **Rolled Curb.** Pioneer Irrigation District Standard Dwg. P-1214 specifies the dimension, general layout and construction to be used for rolled curb driveway approaches for a typical road crossing.

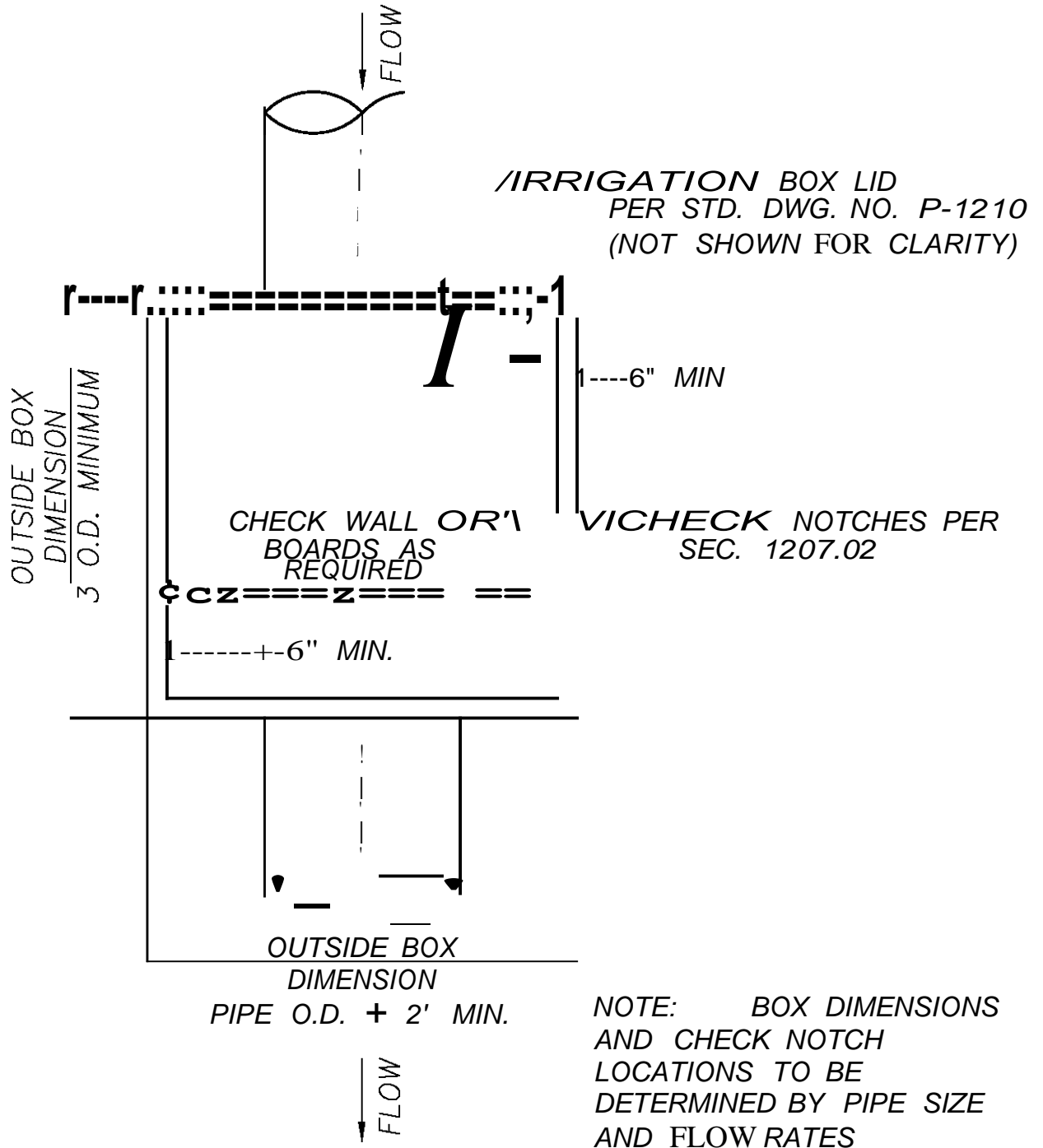

NV0511 P-1208

1-24-18

PIONEER IRRIGATION
DISTRICT

TYP. CHECK STRUCTURE
DETAIL

STANDARD DWG
NO. P-1208

TYPICAL IRRIGATION OR DRAIN INLET

NOTES:

- 1. Min. 7/16" dia. bolts embedded in concrete min. 12". Provide flange over axle and attached to embedded bolts.
- 2. Construct 1/2" min. chamfer on all EXPOSED Vertical Edges.
- 3. Min. 1/4" RadTus tool on all EXPOSED horizontal edges.
- 4. Point and Patch all EXPOSED Snap - tie holes or other holes or cavities to provide durable surface where it is expected to be exposed to view or weather.
- 5. 6" - 6" thick construction shall include #4 Rebar Steel reinforced on 12" centers each way.

PROVIDE SADDLE FLANGE OVER AXLE TO ATTACH TO EMBEDDED BOLT IN BOX

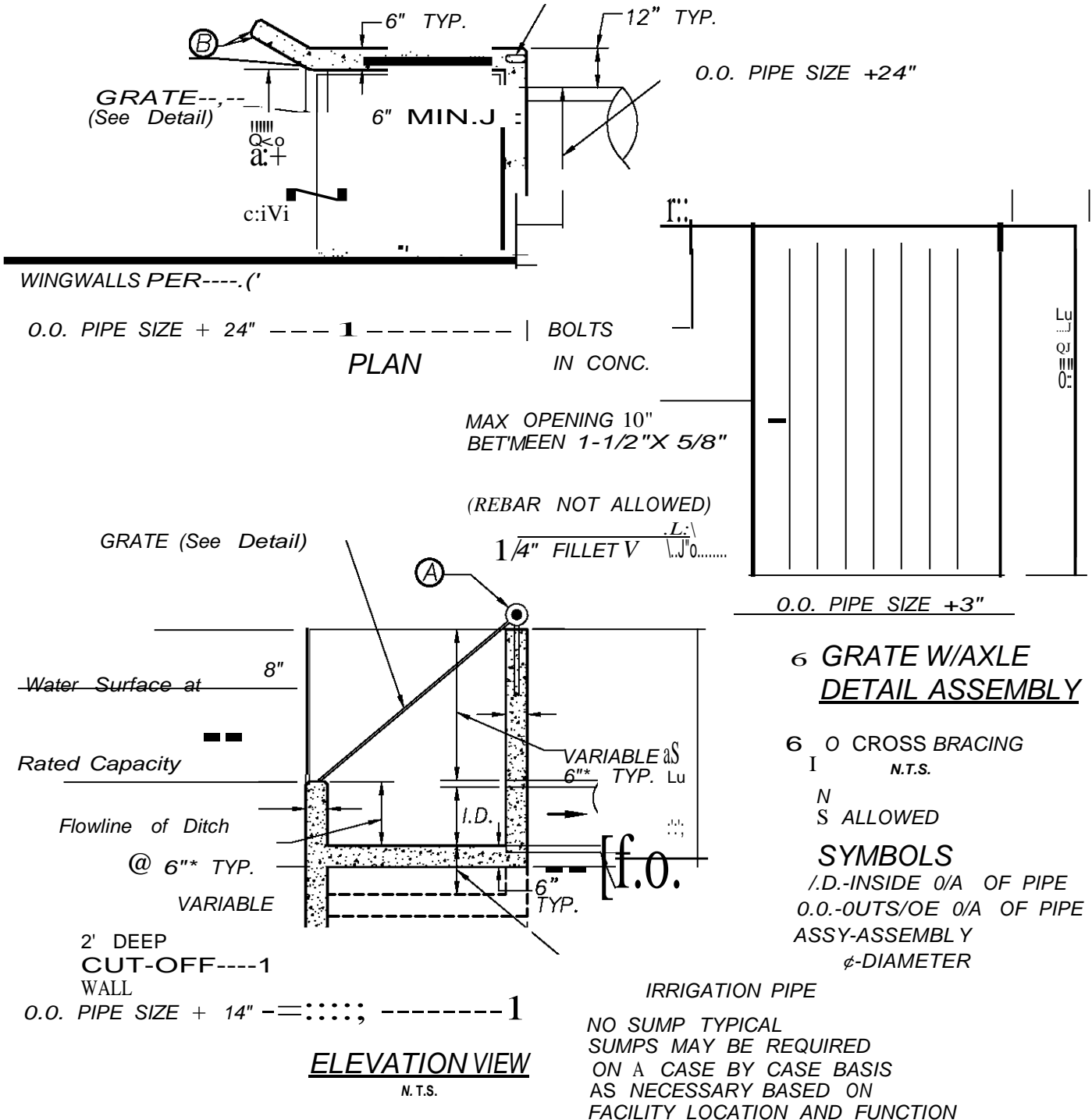

PIONEER IRRIGATION DISTRICT

TYP. IRRIGATION OR DRAIN INLET

STANDARD DWG NO. P-1209

S231
 V) O
 G
 O f
 0
 32
 1
 O
 O
 O
 6
 6
 fT
 0
 tJ
 32
 r
 32
 X
 O

PULL HANDLE
 LOCATION TO BE ON
 ACCESS ROAD SIDE OF
 BOX
 SEE *DETAIL*

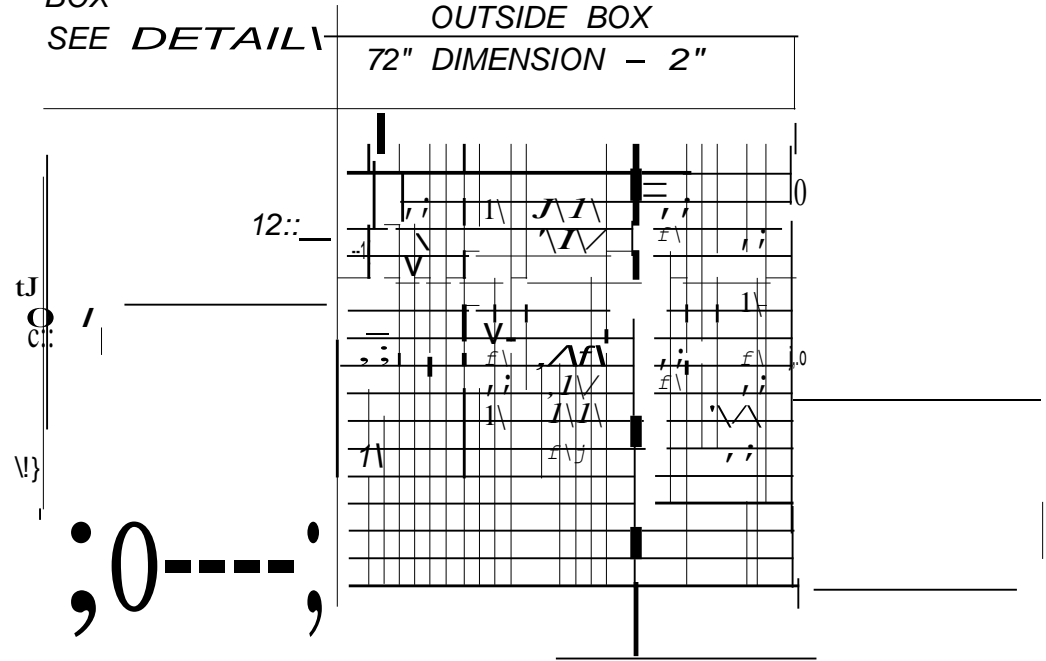

OUTSIDE BOX
 72" DIMENSION - 2"

5# EXPANDED METAL TOP.
 REINFORCE WITH CROSS
 BARS TO MEET PIONEER

IRRIGATION DISTRICT
 STANDARD SECTION 1210

Ujl
 O
 FLOW

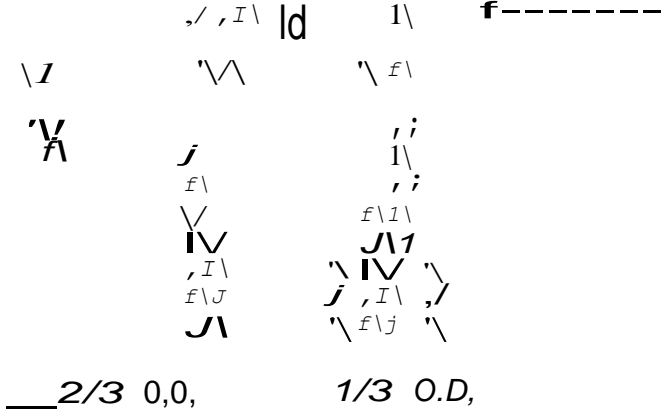
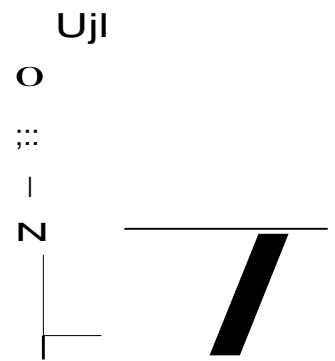

FLOW

EPOXY EYEBOLT
 EMBEDDED 3" MIN.

PULL HANDLE DETAIL

(4) 3/8" O EPOXY ANCHOR

FOR LOCKING PROVIDE
2" LONG x 1" WIDE

)I

BOLT 4" LONG WITH 3"
MINIMUM EMBEDMENT AT

|

! :o
t : J
ot : J

OPENING

o
x

51-02-15

|||||

Jj

EACH CORNER OF 1/3 O.O.
PORTION OF LID.

NYLON LOCK *NUT*;

3/8"X4"X5"
SQUARE U BOLT
W/ METAL STRAP

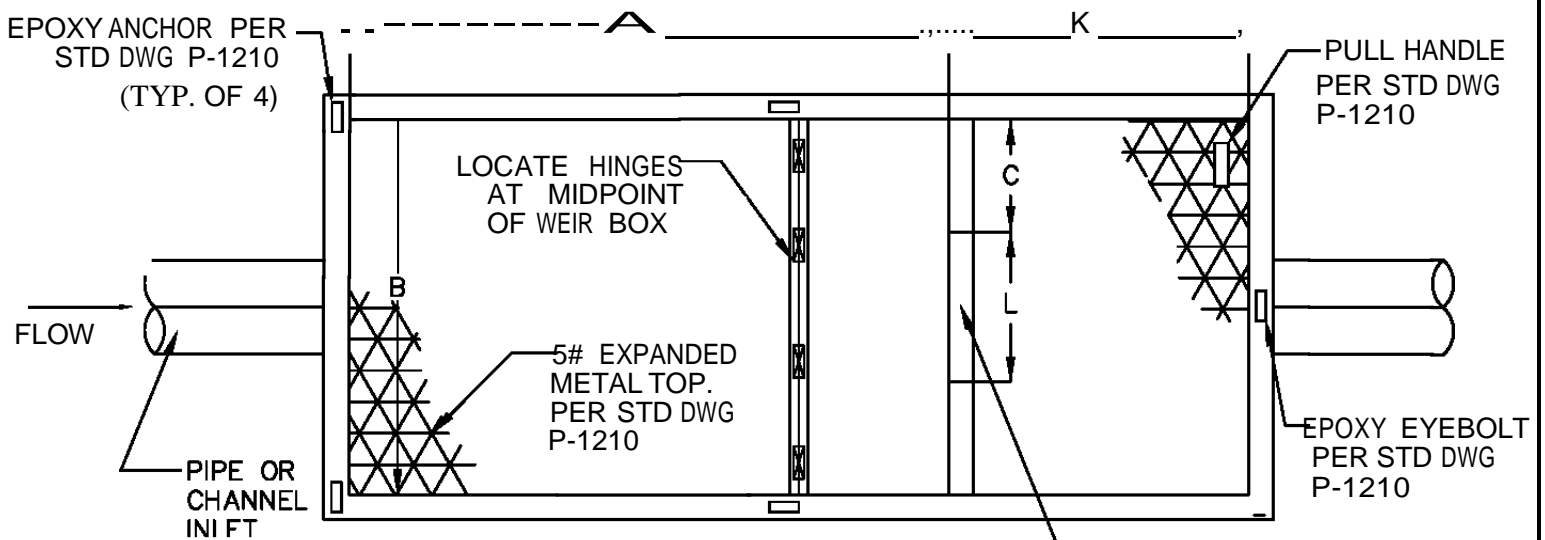

TOP VIEW

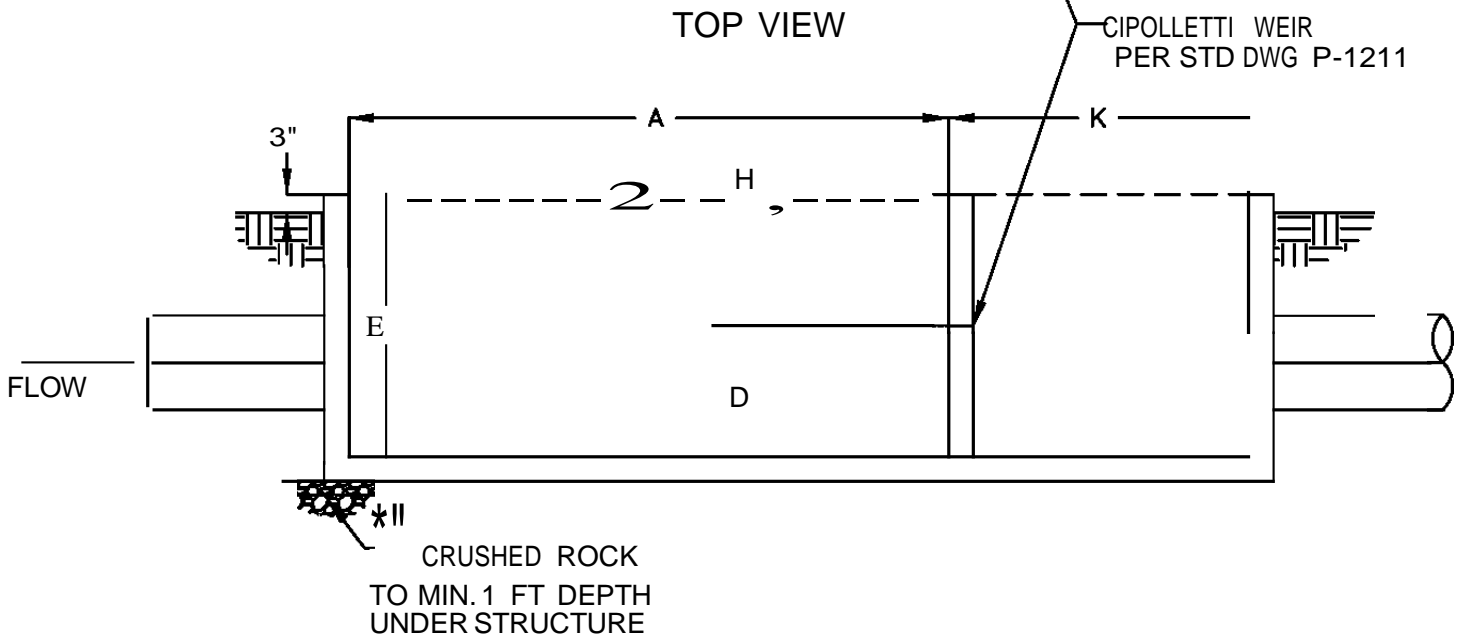

SECTION VIEW

DIS-CHARGE	H	L	A	K	B	E	C	D
	MAXIMUM HEAD	LENGTH OF WEIR CREST	LENGTH OF BOX ABOVE WEIR NOTCH	LENGTH OF BOX BELOW WEIR NOTCH	TOTAL WIDTH OF BOX	MIN. DEPTH OF BOX	DISTANCE FROM END OF CREST TO SIDE OF BOX	DISTANCE FROM CREST TO BOTIOM OF BOX
CFS	FT	FT	FT	FT	FT	FT	FT	FT
1/4 to 3	1	1	6	2	3	3	1	1-1/2
2 to 5	1.1	1-1/2	7	3	4	3	1-1/4	1-1/2
4 to 8	1.2	2	8	4	5	4	1-1/2	1-3/4

PIONEER IRRIGATION DISTRICT

STANDARD WEIR BOX

STANDARD DWG NO. P-1212

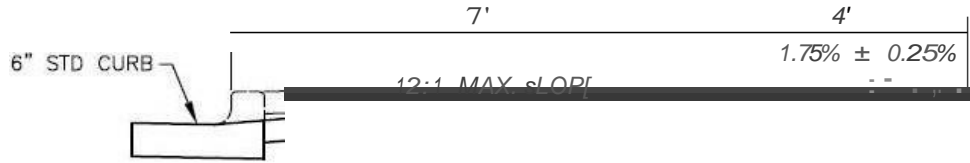

SECTION A-A
N. T.S.

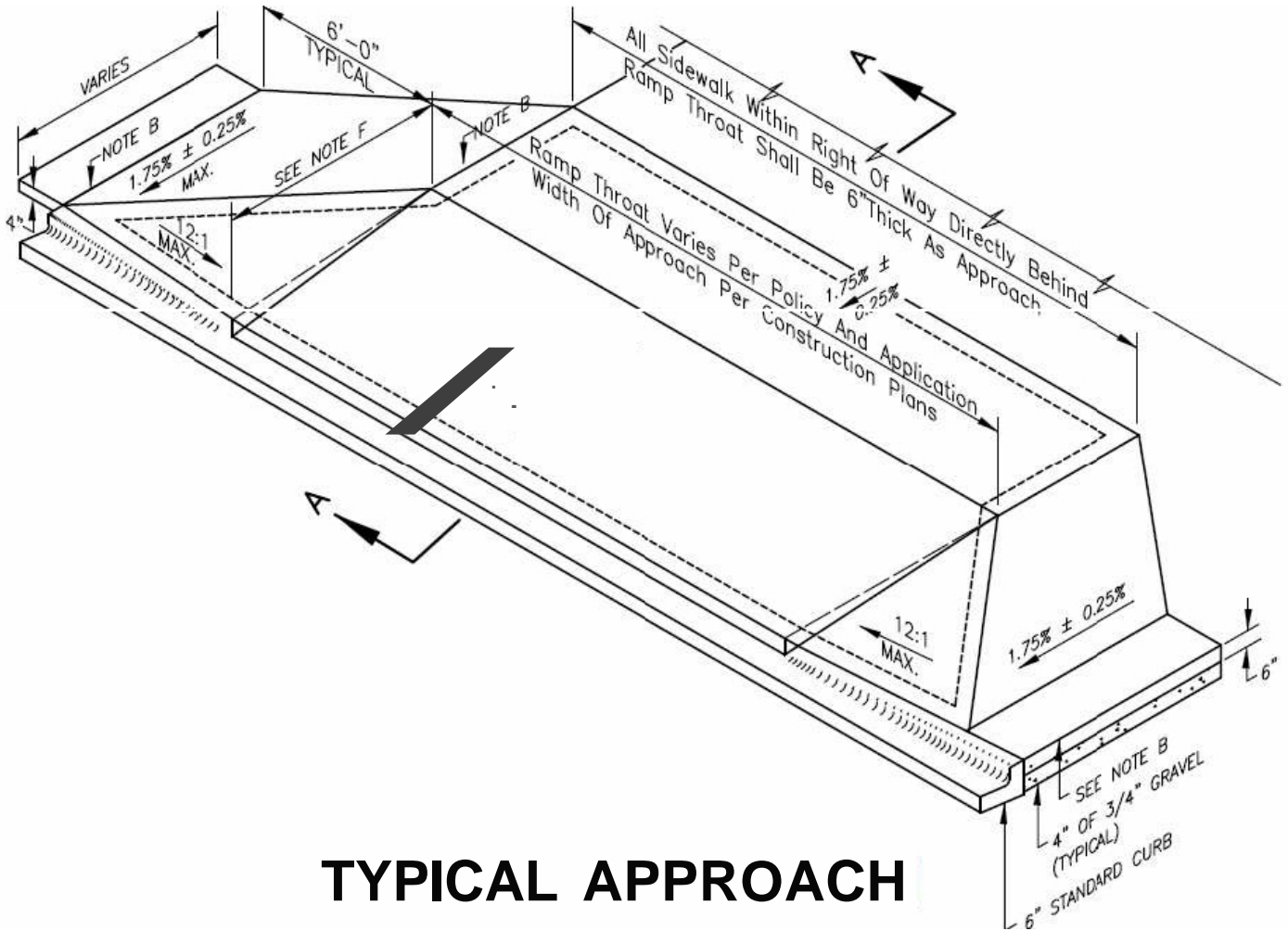

TYPICAL APPROACH

NOTES:

- Ⓐ APPROACH TO CONFORM TO THE LATEST A.D.A. STANDARDS.
- Ⓑ INSTALL EXPANSION JOINT AT TIP OF APPROACH WINGS AND WHERE SIDEWALK CHANGES THICKNESS.
- Ⓒ BASE TO BE 1, 4" THICKNESS OF 3/4" MINUS CRUSHED AGGREGATE PER ISPWV SECTION - 802.
- Ⓓ APPROACH THROAT WIDTHS SET BY POLICY AND APPLICATION. ALL CONCRETE TO BE 6" THICK FROM TIP OF WING TO TIP OF WING UP TO THE EXPANSION JOINT. WHEN SIDEWALK IS SEPARATE FROM CURB THE SIDEWALK IMMEDIATELY BEHIND THE APPROACH THROAT SHALL BE 6" THICK ALSO.
- Ⓔ ALL CONCRETE SHALL BE CLASS 3000 PER ISPWV SECTION - 703.
- Ⓕ SIDEWALK WIDTH MAY VARY.

PIONEER IRRIGATION
DISTRICT

CONCRETE DRIVEWAY WITH
SIDEWALK AROUND APPROACH

P-1213

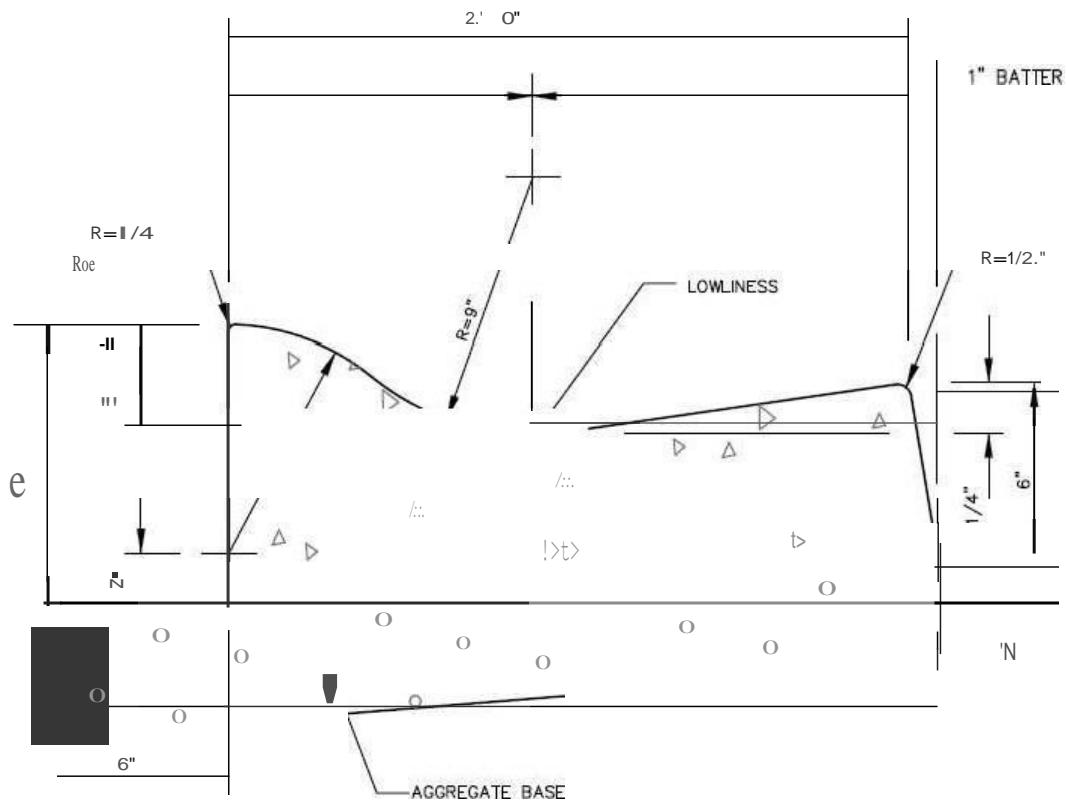

NOTES:

- GRADE AND ALIGNMENT TO BE ESTABLISHED OR APPROVED BY THE ENGINEER AND THE PUBLIC AGENCY HAVING JURISDICTION.
- @ BASE: 4-INCH COMPACTED DEPTH OF 3/4-INCH MINUS CRUSHED AGGREGATE BASE MATERIAL, PLACED AS SPECIFIED AND PAID UNDER SECTDN-802. ISPWC; COMPACTED TO EXCEED 96F STANDARD PROCTOR.
- @ 1/2-INCH PREFORMED EXPANSION JOINT MATERIAL (AASHTO M 213) AT TERMINAL POINTS OF RADII.
- Ⓡ CONTINUOUS PLACEMENT PREFERRED. SCORE INTERVALS AT 10- FEET MAXIMUM SPACING (OR CONSISTENT WITH 2x SIDEWALK WIDTH FOR SCORE SPACING.)
- Ⓡ MATERIALS AND CONSTRUCTION IN COMPLIANCE WITH ISPWC SPECIFICATIONS.
- Ⓡ BACKFILL AS PER ISPWC SECTION-706.
- @ SECURE RIGHT-OF-WAY PERMT BEFORE BEGINNING CONSTRUCTION IN PUBLIC RIGHT-OF-WAY.
- Ⓡ USE ROLLED CURB IN RESIDENTIAL AREAS. WHEN LOCAL JURISDICTION REQUIRES VERTICAL CURB AT INTERSECTIONS VERTICAL CURB LENGTH TO BE FULL RADIUS PLUS 5 FEET AT EACH END. TRANSITION LENGTH FROM ROLLED CURB TO VERTICAL CURB 2. FEET.