



**Bobcat**®

**PALLET FORK ATTACHMENT**



***One Tough Animal***™

**IR** Ingersoll Rand  
Compact Vehicle Technologies

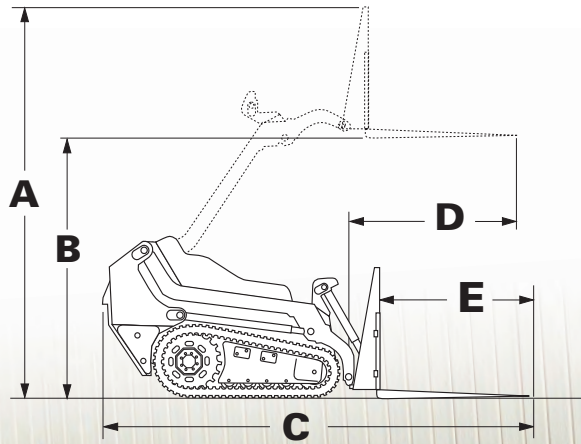
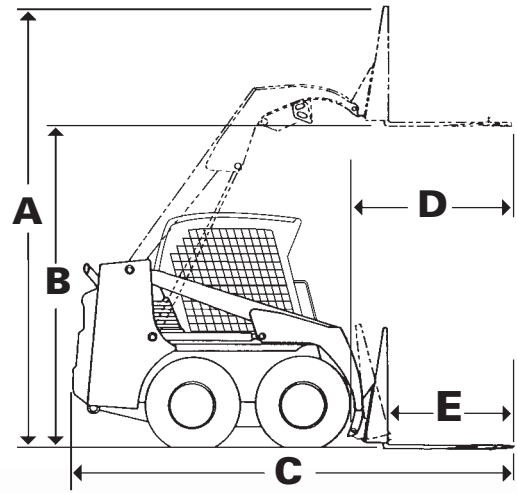
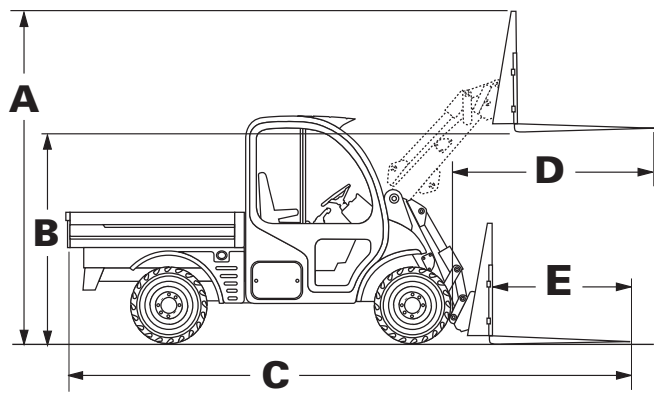

## Specifications

### PALLET FORK SPECIFICATIONS

Frame	Frame Width	Frame Height	Frame Weight	Tooth Length	Tooth Wt. (set of 2)	Total Weight
<b>Small</b>	37 in.	34.5 in.	105 lb.	30 in. 36 in.	130 lb. 147 lb.	235 lb. 252 lb.
<b>Standard</b>	46 in.	39 in.	200 lb.	30 in. 36 in. 42 in. 48 in.	130 lb. 147 lb. 164 lb. 181 lb.	330 lb. 347 lb. 364 lb. 381 lb.
<b>Heavy-Duty</b>	60 in.	49 in.	470 lb.	42 in. 48 in.	214 lb. 238 lb.	684 lb. 708 lb.

### SMALL PALLET FORK (with 36 in. teeth)

Loader Size	A	B	C	D	E
<b>MT52</b>	101 in.	66 in.	110 in.	45 in.	36 in.
<b>MT55</b>	101 in.	66 in.	113 in.	51 in.	36 in.
<b>463</b>	124 in.	90 in.	120 in.	40 in.	36 in.

### STANDARD PALLET FORK (with 48 in. teeth)

Loader Size	A	B	C	D	E
<b>553</b>	137 in.	98 in.	142 in.	55 in.	48 in.
<b>S100</b>	137 in.	98 in.	—	58 in.	48 in.
<b>S130</b>	142 in.	103 in.	150 in.	61 in.	48 in.
<b>S150/S160</b>	148 in.	109 in.	156 in.	57 in.	48 in.
<b>S175/S185</b>	151 in.	113 in.	156 in.	67 in.	48 in.
<b>S205</b>	151 in.	112 in.	156 in.	68 in.	48 in.
<b>S220</b>	156 in.	116 in.	169 in.	62 in.	48 in.
<b>S250*</b>	156 in.	123 in.	169 in.	70 in.	48 in.
<b>T140</b>	143 in.	104 in.	150 in.	61 in.	48 in.
<b>T180</b>	151 in.	109 in.	156 in.	57 in.	48 in.
<b>T190</b>	151 in.	112 in.	158 in.	68 in.	48 in.
<b>5600-C</b>	117 in.	77 in.	202 in.	79 in.	48 in.
<b>5600-D</b>	117 in.	79 in.	202 in.	78 in.	48 in.

### HEAVY-DUTY PALLET FORK (with 48 in. teeth)

Loader Size	A	B	C	D	E
<b>S220</b>	167 in.	117 in.	169 in.	70 in.	48 in.
<b>S250*</b>	173 in.	123 in.	169 in.	78 in.	48 in.
<b>S300*</b>	171 in.	123 in.	172 in.	78 in.	48 in.
<b>S330</b>	171 in.	123 in.	172 in.	77 in.	48 in.
<b>A300*</b>	171 in.	123 in.	172 in.	78 in.	48 in.
<b>T250</b>	166 in.	117 in.	169 in.	70 in.	48 in.
<b>T300/T320*</b>	173 in.	123 in.	169 in.	78 in.	48 in.

\*Dimensions A and B will be 2 inches less on machines older than K-series



## Specifications

### HYDRAULIC PALLET FORK RATINGS

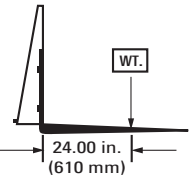

Loader Rated Operating Capacity		
900 lb.	360 lb.	(160 kg)
1300 lb.	550 lb.	(250 kg)
1500 lb.	655 lb.	(295 kg)
1700 lb.	845 lb.	(380 kg)
1900 lb.	990 lb.	(450 kg)
2100 lb.	1050 lb.	(475 kg)
2300 lb.	1150 lb.	(520 kg)
2500 lb.	1250 lb.	(565 kg)
2700 lb.	1350 lb.	(610 kg)
3000 lb.	1680 lb.	(760 kg)

- Adjust fork spacing with fingertip controls inside the cab
- Two hydraulic cylinders adjust outside spacing width from 40.25 in. to 12 in.
- Two sizes of forks to choose from: 42 in. and 48 in.

NOTE - Where applicable, dimensions are in accordance with Society of Automotive Engineers (SAE) and ISO standards. Specifications and design are subject to change without notice. Pictures of Bobcat units may show other than standard equipment. All dimensions are given for loader equipped with standard tires. All dimensions are shown in inches. Respective metric dimensions are enclosed by parentheses. Bobcat Company complies with the requirements of ISO 9001 as registered with BSI.

### HYDRAULIC PALLET FORK SPECIFICATIONS

Frame	Frame Width	Frame Height	Frame Weight	Tooth Lengths	Tooth Wt. (set of 2)	Total Weight
Hydraulic	48 in.	39 in.	383 lb.	42 in. 48 in.	164 lb. 181 lb.	547 lb. 564 lb.

*The Bobcat Attachments Advantage: Bobcat attachments are engineered and manufactured to fit Bobcat loaders for optimum job performance, dependability and durability.*



**Bobcat Pallet Fork Attachment fits these carrier models:**

**Mini Track Loaders:**  
MT52  
MT55

**Skid-Steer Loaders:**  
463  
553

S100  
S130  
S150  
S160  
S175  
S185  
S205  
S220  
S250  
S300  
S330

**Compact Track Loaders:**  
T140  
T180  
T190  
T250  
T300  
T320

**All-Wheel Steer Loaders:**  
A300

**Utility Work Machine:**  
5600

**Bobcat Hydraulic Pallet Fork Attachment fits these carrier models:**

**Skid-Steer Loaders:**  
S130  
S150  
S160  
S175  
S185  
S205  
S220  
S250  
S300  
S330

**Compact Track Loaders:**  
T140  
T180  
T190  
T250  
T300  
T320

**All-Wheel Steer Loaders:**  
A300



B-1378 (9/07)

**Bobcat Company**  
P.O. Box 6000 • West Fargo, ND 58078  
[www.bobcat.com](http://www.bobcat.com)

Printed in U.S.A.



Kn-5M-907-#9995-F