



GALVANIZED, STAINLESS AND COPPER LOUVER

MODEL: 4-SRF-ML
IMPACT RESISTANT LOUVER



APPLICATION

The 4-SRF-ML Stationary Louver with Flange Frame is a 4" deep metal louver for protection of high air intake velocities and exhaust in building exterior walls.

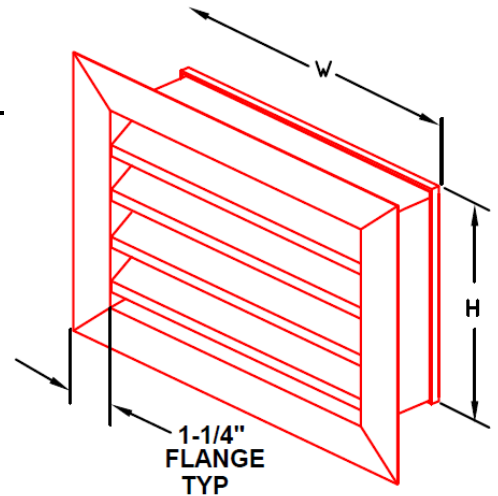

SPECIFICATIONS

- Frame:** 26 gauge Galvanized steel
- Blade:** 26 gauge Galvanized steel
- Blade Spacing:** Approximately 3-1/4" center to center (except at head and sills)
- Fasteners:** Spot weld
- Blade Angle:** 36°
- Screen:** Bird screen
1/2" x 1/2" galvanized steel
- Flange:** 1-1/4"

OPTIONS

- Frame & Blade:** 26 gauge 316 stainless steel
Copper
- Finish:** Powder Coat Paint
Baked Enamel Paint

- Insect Screen 1/16" x 1/16" galvanized steel
- Bird Screen 1/2" x 1/2" galvanized steel

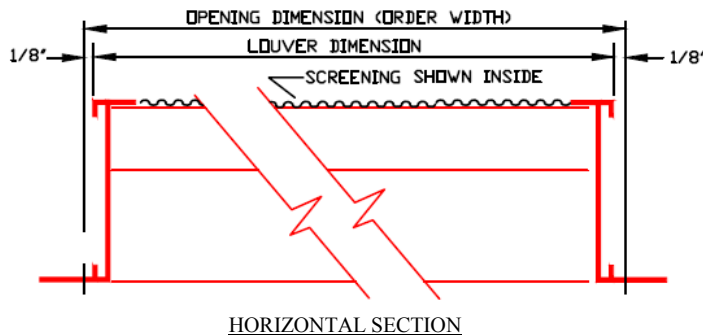
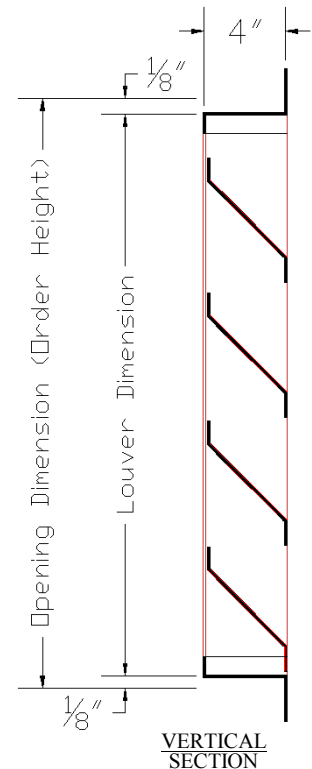

B1, 4/F., Luen Ming Hing Factory Building
36 Mok Cheong St.,
To Kwa Wan, Kowloon, H. K.
Tel: 852-2760-4188 Fax: 852-2760-4177
Email: tatanlexyim@lloydasia.com



231 Commerce Dr. Montgomeryville, PA 18936
Tel: 215-412-4445 Fax: 215-412-4409
Email: lloydind@firedamper.com

138 Industrial Loop West, Orange Park, FL 32073
Tel: 904-541-1655 Fax: 904-541-1657
Email: lloydind1@bellsouth.net

Website: www.firedamper.com

*ALL STATED SPECIFICATIONS ARE SUBJECT TO UPDATE WITHOUT NOTICE OR OBLIGATION.