

# SHARP®

## PN-V551 PN-V550

Ultra-Slim Bezel LED Displays

### Sharp's 55" Class (54.6" diagonal) Full-HD Displays Expand Choices for Video Wall Installations



# High-Quality Digital Signage Solution Offers Style and Precision

Sharp's 55" Class (54.6" diagonal) full high-definition PN-V551 and PN-V550 professional LED monitors allow you to build video walls with exceptionally thin 3.5 mm\* ultra-slim bezels that will complement virtually any commercial or public space. Whether installed in a shopping mall, hotel, control room, transport hub, or conference hall, a bank of these monitors will convey your message with overwhelming style and precision. Four PN-V551 or PN-V550 monitors set up in a 2 x 2 configuration, for example, will let you display every last pixel of native 4K Ultra HD (3,840 x 2,160-pixel) content on the equivalent of a 110" Class screen. Thanks to Sharp UCCT (Uniform Color Calibration Technology), color reproduction and brightness are beautifully consistent on each individual LCD monitor and thus across the entire video wall.

\* 3.5 mm is the minimum combined frame width for neighboring monitors, excluding the gap between the monitors.

## Dynamic Video Wall Setup Delivers High Visual Impact

Whether in a commercial or business setting, multiple full-HD PN-V551/V550 monitors can be joined together to create an eye-catching video wall that expands the reach of your message. Multi-monitor configurations are easy to assemble and easy to control via the RS-232C interface or via a network.



5 x 5 video wall (Simulated image)

## Excellent Image Quality

The PN-V551 and PN-V550 monitors combine full-HD (1,920 x 1,080-pixel) resolution with a display brightness of 700 cd/m<sup>2</sup> and 500 cd/m<sup>2</sup>, respectively, to deliver stunningly bright and detailed images. Full-HD resolution helps ensure that everything from fine text to intricate graphics is displayed crisply and clearly. Four PN-V551/V550 monitors set up in a 2 x 2 configuration, for example, can beautifully render every single pixel of 4K Ultra HD (3,840 x 2,160-pixel) content in a form equivalent to a 110" class LCD monitor. What's more, Sharp UCCT (Uniform Color Calibration Technology) helps realize brilliant uniformity of color and brightness.



2 x 2 video wall (Simulated image)

## Sharp UCCT (Uniform Color Calibration Technology) Significantly Increases Uniformity of Color\*

To varying degrees, unevenness of color and brightness may occur in LCDs. To compensate for this, Sharp UCCT helps ensure uniformity of color and brightness across the entire LCD monitor by properly adjusting color levels with high precision and high definition (at the pixel level).

### Hybrid Correction of RGB Color and Brightness

Close-up image of LCD



The display characteristics of each small area in the LCD are measured in terms of various RGB input signals. Uniformity of color and brightness is then calibrated and corrected for each RGB signal element in a given area, as shown in the graphs below.

#### Gamma correction for RGB elements (part of the correction processing method)

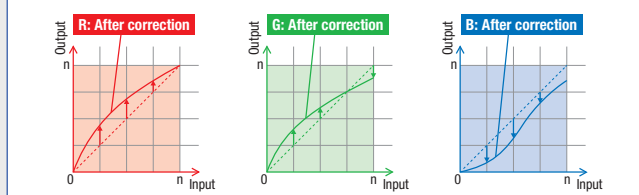

\* Brightness level may decrease when activating UCCT.

### Simulated image of color uniformity calibration by Sharp UCCT

Before Calibration



After Calibration



Simulated images.

## Ultra-Slim Bezel

The ultra-slim bezels on PN-V551/V550 monitors enable you to combine multiple units to create a virtually seamless digital canvas. The bezels of adjacent monitors in a video wall combine for a total bezel width of just 3.5 mm\*1 — 1.2 mm on the right and bottom sides, and 2.3 mm on the left and top sides\*2. This enables the display of large, crisp images with minimal distraction and maximal impact.



\*1: Minimum combined frame width for neighboring monitors, excluding the gap between them.

\*2: Non-display area for neighboring monitors is 3.9 mm.

## Four-Corner Carrying Handles for Safe Setup

To help ensure safe handling of a PN-V551/V550 monitor, all four of its corners are fitted with robust carrying handles. Together with the monitor's light weight of 60.2 lbs, these handles help enable safe transport and easy, time-saving installation — whether vertically or horizontally.

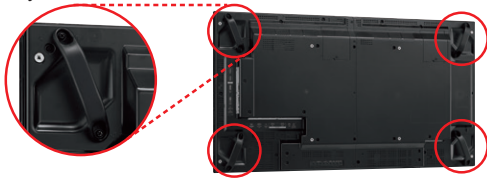

## Control Kit (PN-ZR01A)

When one of the monitors in a video wall is fitted with a remote control sensor box, all of the monitors can be conveniently operated through one remote control unit.



Remote controller

Remote control sensor box

## Mirror Frames (PN-ZR42/ZR43\*3)

In multi-monitor configurations, optional Mirror Frames help minimize\*4 the visible lines between slim-bezel PN-V551/V550 monitors by reflecting mirror images of the display content. This creates more dynamic video walls and an even smoother big-picture effect.

### A Multi-Monitor Configuration with Mirror Frames



(Simulated images)



Without Mirror Frames



With Mirror Frames

\*3 PN-ZR42: long mirror frame; PN-ZR43: short mirror frame

\*4 The visibility of the seams between monitors varies depending on such factors as the on-screen image and the viewing angle.

## 24/7 Operation

Built solid, the PN-V551/V550 monitors are ideal for use in 24-hour stores and in other demanding professional applications that require round-the-clock operation seven days a week.

## Choice of Installation Mode

The PN-V551/V550 displays offer a choice of landscape or portrait installation, allowing customers to select the mode that best suits their display content and application.



# Specifications

Model Name		PN-V551	PN-V550
Installation		Landscape / Portrait	
LCD Panel		55" Class widescreen (54.6" diagonal) TFT LCD	
	Max. Resolution	1,920 x 1,080 pixels	
	Max. Display Colors (approx.)	16.77 million colors	
	Pixel Pitch (H x V)	0.63 x 0.63 mm	
	Brightness*1	700 cd/m <sup>2</sup> (default: 550 cd/m <sup>2</sup> )	500 cd/m <sup>2</sup> (default: 400 cd/m <sup>2</sup> )
	Contrast Ratio*1	3,500 : 1	4,000 : 1
	Viewing Angle (H/V)	178°/178° (CR ≥ 10)	
	Active Screen Area (W x H)	47 5/8" x 26 13/16"	
	Response Time	8 ms (grey to grey, avg.)	
	Backlight	LED, full array	
Computer Input	Video	Analog RGB (0.7 Vp-p) [75 Ω], Digital (conforms to DVI 1.0 standards), DisplayPort 1.1	
	Synchronization	Horizontal/vertical separation (TTL: positive/negative), Sync-on-green*2, Composite sync*2 (TTL: positive/negative)	
	Plug & Play	VESA DDC2B	
	Power Management	VESA DPMS, DVI DMPM	
Video Color System		NTSC (3.58 MHz, 4.43 MHz), PAL, PAL60, SECAM	
Input Terminals*3		HDMI™*4 x 1, Mini D-sub 15-pin x 1*5, video x 1*5, Component video x 1*5, DisplayPort x 1, DVI-I-29 pin (HDCP compatible) x 1, 3.5 mm-diameter mini stereo jack x 1, RS-232C x 1, D-sub 9-pin x 1, Control kit terminal x 1	
Output Terminals*3		DisplayPort*6 x 1, DVI-D 24-pin (HDCP compatible) x 1, 3.5 mm-diameter mini stereo jack x 1, RS-232C x 1, D-sub 9-pin x 1	
Input/Output Terminals*3		LAN port	
Mounting		VESA (4 points), 400 mm (15 3/4") pitch	
Power Supply		100V—240V AC, 50/60 Hz	
Power Consumption		210 W	185 W
Environmental Conditions	Operating Temperature	0°C to 40°C	
	Operating Humidity	20% to 80% RH (no condensation)	
Dimensions*7 (W x D x H) (approx.)		47 3/4" x 4 1/2" x 26 15/16"	
Weight (approx.)		60.2 lbs	55.1 lbs
Main Accessories		Cable clamp x 4, cable clamp (insertion type) x 2, power cord x 1, CD-ROM x 1, set-up manual x 1, remote control sensor box mounting hole concealing sticker x 2	

\*1 Brightness and contrast ratio depend on input mode and other picture settings. Brightness level will decrease slightly over the lifetime of the product. Due to the physical limitations of the equipment, it is not possible to maintain a precisely constant level of brightness. \*2 D-sub input terminal only. \*3 Use a commercially available connection cable for PC and other video connections. \*4 For both PC and AV components. \*5 Analog PC, video, and component video are switchable (via the bottom interface); use the menu to select. Note that video and component video inputs require a conversion cable connected via the mini D-sub 15-pin jack. \*6 For video signals only. \*7 Display only, not including protrusions.

## Dimensions

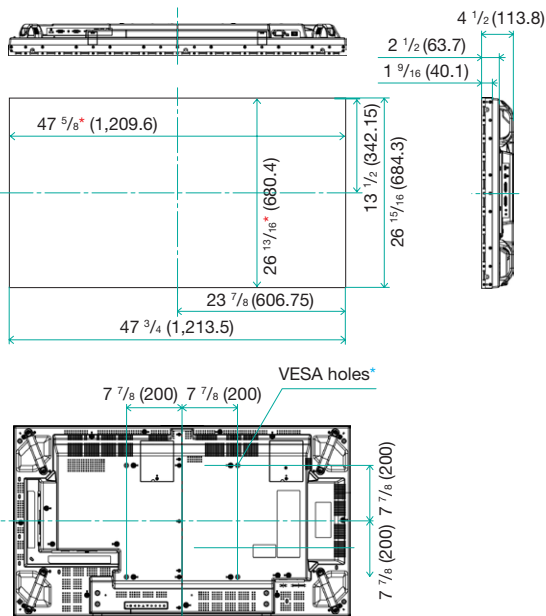

Units: inch (mm)  
 \* Screen dimensions  
 \* To use the VESA-standard mounting bracket, use M6 screws that are 8 to 10 mm plus the thickness of the bracket.

## Input/Output Terminals

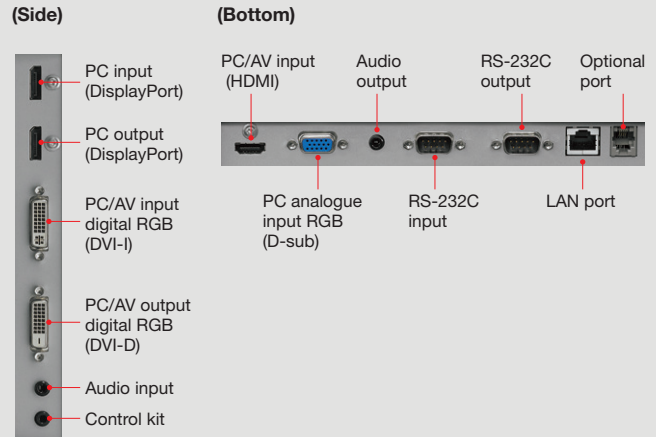

## Options

- PN-ZR01A: Control Kit (remote controller and remote control sensor box)
- PN-ZR42: Long Mirror Frame
- PN-ZR43: Short Mirror Frame



Printed with environmentally friendly vegetable oil-based ink.



SHARP ELECTRONICS CORPORATION  
 1 Sharp Plaza, Ste.1, Mahwah, NJ 07495-1123  
 1-800-BE-SHARP • www.sharpusa.com

Design and specifications are subject to change without notice. Sharp is a registered trademark of Sharp Corporation. DisplayPort and the DisplayPort Compliance Logo are trademarks owned by the Video Electronics Standards Association in the United States and other countries. HDMI, the HDMI logo, and High-Definition Multimedia Interface are trademarks or registered trademarks of HDMI Licensing, LLC in the United States and other countries. All other brand names and product names may be trademarks or registered trademarks of their respective owners. All screen images appearing in this brochure are simulated.