

RMP60 - radio machine probe

www.renishaw.com/rmp60

RMP60 probe system with radio signal transmission.

When switched on, the probe transmits omnidirectionally for ease of operation on vertical, horizontal CNC machining centres and vertical turning lathes.

The RMI is fully described in a separate data sheet - please see parts list on back page.

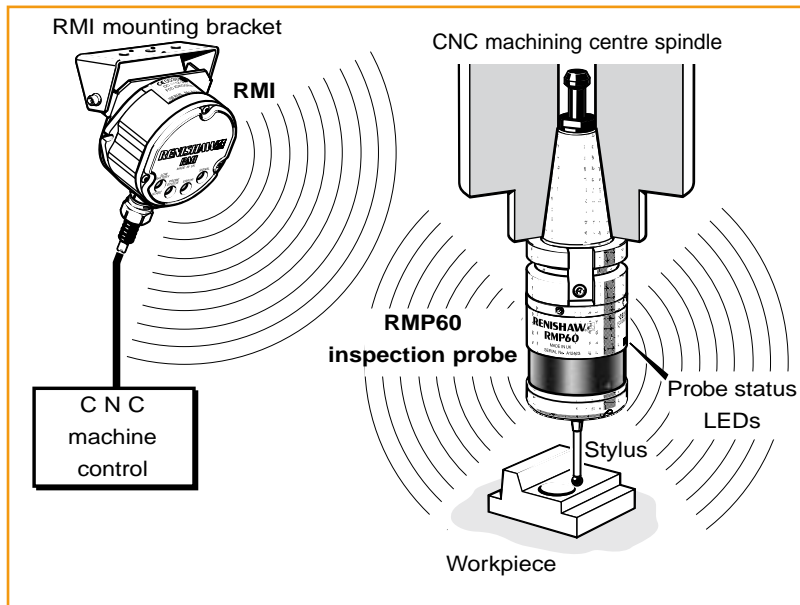

Features

- The RMP60 is a compact 3D touch-trigger probe ($\pm X$, $\pm Y$, $+Z$ sense directions) with radio transmission, used for workpiece set-up and inspection on small to large CNC machining centres and vertical turning lathes.
- The RMP60 transmits data omnidirectionally to a range of up to 15 m (49.2 ft).
- Ease of installation.
- A standard battery life of 140 hours continuous use, or the equivalent of approximately 100 days at 5 % usage is achievable. For applications requiring greater battery life, certain high capacity lithium thionyl chloride batteries can be used.
- Repeatability, 1.0 μm (40 μin) is certified at 480 mm/min (1.57 ft/min) with 50 mm stylus.
- Probe switch on is user configurable between M code, spin or shank.
- Probe switch off is user configurable between M code, time, spin or shank switch dependant on turn on method.
- Sealed to IPX8 for the machine tool environment, IPX5 with battery cassette removed.
- 2.4 GHz radio transmission, enables a single system for worldwide use.
- Interference-free channel hopping transmission.
- No channel selection required.
- RMP60 meets the radio regulations of:
 - Europe: CE 0536!
 - USA: FCC ID: KQGRMP60, FCC ID: KQGRMP60V2, FCC ID: KQGRMP60MV2
 - Japan: RMP60: 004NYCA0042, RMP60: 004NYCA0406, RMP60M: 004NYCA0407
 - Canada: IC: 3928A-RMP60, IC: 3928A-RMP60V2
 - Australia, China, Israel, New Zealand, Russia, Switzerland, India, South Africa, Thailand, Korea, Turkey, Indonesia, Malaysia, Mexico, Brazil, Taiwan
- Partner RMP60 and RMI systems allow interference-free multiple probe installations.
- The RMP60 is suitable for use with Renishaw single and double touch probing cycles.
- User adjustable trigger force for long/cranked styli.
- A weak link is included in each kit to protect the probe in the event of excessive stylus overtravel, when using steel styli.

Operating envelope - RMP60/RMI

The RMP60 transmission envelope and range is shown below.

The probe system should be positioned so that the optimum range can be achieved over the full travel of the machine's axes including the tool magazine. Always face the RMI in the direction of the machine's spindle and tool magazine.

If the probe is not in range when located in the tool magazine, use spin or shank turn on.

The RMP60 and RMI must be within a mutual operating envelope. The operating envelope shows line-of-sight performance. However, radio transmission does not require line-of-sight as long as any reflected radio path is less than the 15 m (49.2 ft) system operating range.

A minimum range 100 mm (0.33 ft) is recommended.

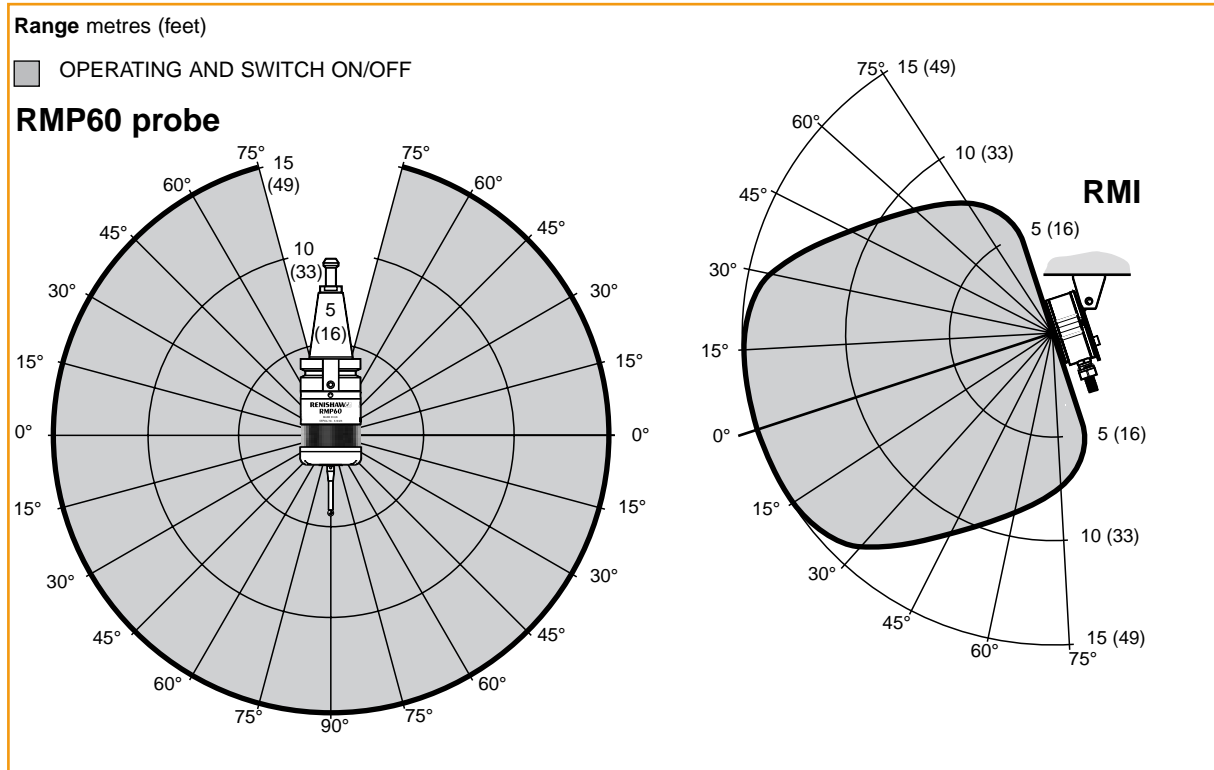

Dimensions

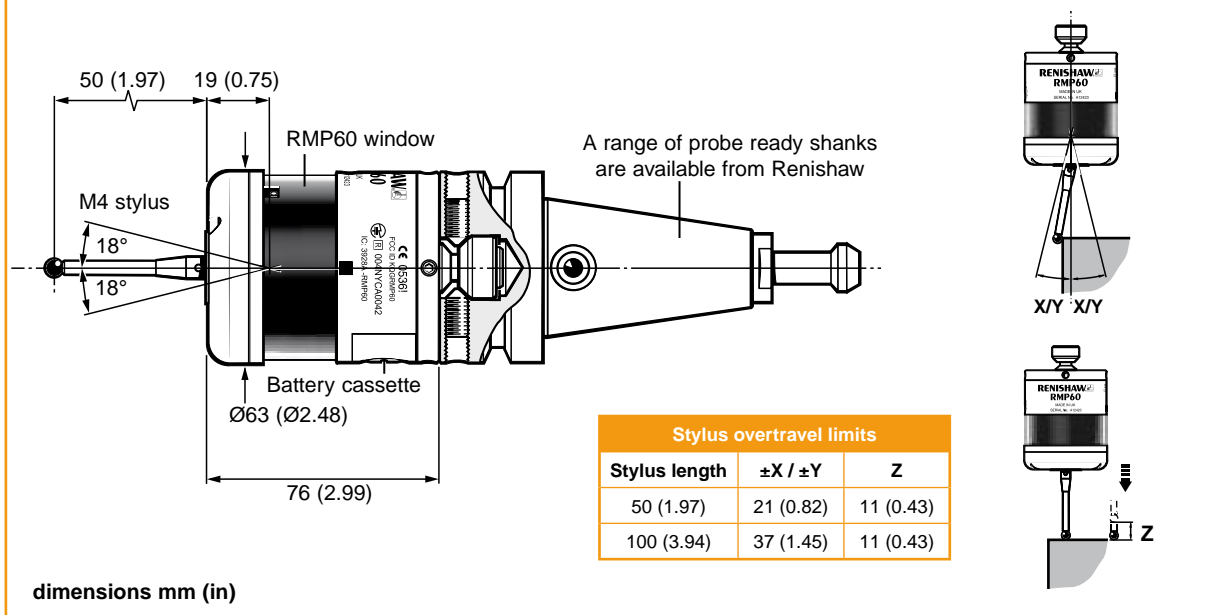

System operation

Prior to probe operation, it is imperative that the program selected to 'drive' the probe has been verified. Incorrect programming could result in damage to the machine, workpiece and probe system.

The RMP60 probe operates in one of three modes:







- Stand-by mode** - The RMP60 uses a small current, while waiting for a switch-on signal to be received.
- Operating mode** - Activated by one of the methods described below. Signals are only transmitted by the probe in this mode and the probe is now ready for use.
- Configuration mode** - Trigger Logic™ allows a number of probe set-up options to be programmed, by triggering the probe when the batteries are inserted. Programmable options are described on the next page.

Probe environment

RMP60/RMI	Temperature
Storage	-10 °C to 70 °C (14 °F to 158 °F)
Normal operating	5 °C to 50 °C (41 °F to 122 °F)

Probe status LEDs

When operating the probe, status LEDs give a visual indication of probe status (triggered or seated) and battery condition.

LED Colour	Probe status	Graphic hint
Unit	Stand-by mode or hibernate	
Flashing green	Probe seated in operating mode	
Flashing red	Probe triggered in operating mode	
Flashing green and blue	Probe seated in operating mode - low battery	
Flashing red and blue	Probe triggered in operating mode - low battery	
Constant red	Battery dead	
Rapid flashing red	Extremely dead alkaline batteries or unsuitable lithium thionyl chloride batteries	

Battery dead - at this stage probe status is forced open and the probe cycle will stop.

Probe specification

Primary application	Inspection probe for machining centres
Operating range	100 mm (0.33 ft) to 15 m (49.2 ft)
Sense directions	Omni-directional $\pm X \pm Y \pm Z$
Weight (without a shank) with batteries without batteries	901 g (31.79 oz) 855 g (30.16 oz)
Stylus trigger force using 50 mm (1.97 in) stylus low force direction	factory setting XY 0.75 N / 75 gf (2.65 ozf) Z 5.30 N / 530 gf (18.69 ozf)
Stylus trigger force using 50 mm (1.97 in) stylus high force direction	factory setting XY 1.4 N / 140 gf (4.94 ozf) Z 5.30 N / 530 gf (18.69 ozf)
Max. spin speed	1000 rev/min
Stylus Overtravel	XY 18° Z 11 mm (0.43 in)
Sealing	IPX8 (BS 5490, IEC 529) 1 atmosphere
Repeatability	1.0 μm (0.00004 in) is valid for maximum 2σ value in any direction test velocity of 480 mm/min (1.57 ft/min) at stylus tip, using stylus 50 mm (1.97 in) long.

Multiple probe mode

RMP60 can be user configured using Trigger Logic™ to allow multiple RMP60s to be used with a single RMI.

Notes:

Radio turn on cannot be used in multiple probe mode. RMP60s set to 'mode-on' can coexist alongside any number of RMP60's set to 'mode-off'.

To allow multiple probes/single RMI in close proximity, 16 choices of 'mode-on' colours are available – each representing a different machine tool installation.

Only one of the multiple probes per machine will need partnering as, by configuring multiple probes to a single 'mode-on' choice, all probes have the same identification. The probe to be partnered is partnered after selection of multiple probe on mode.

There is no limit to the number of probes that can be used with a single RMI as long as they all have the same 'mode-on' colour choice.

All RMP60s are factory-set to 'mode off'.

The addition of further probe(s) into a single probe installation requires all probes to be reconfigured to the same multiple probe 'mode-on' choice and the repartnering of one of the probes to the installed RMI.

The addition of further probes (or replacements) into a multi probe installation is achieved simply by reconfiguration to the same 'mode-on' colour choice.

Comprehensive details of how to set-up and change multiple probe settings are included in the RMP60 installation and user's guide, H-2000-5219.

Probe switch on and off

The probe is switched on by one of the following options.
All options are user configurable.

RMP60 switch on method Switch on options are configurable	RMP60 switch off method Switch off options are configurable	Switch on time
Radio on Radio switch on is commanded by machine input.	Radio off Radio switch off is commanded by machine input. A timer automatically switches the probe off 90 minutes after the last trigger if it is not turned off by machine input. Timer off (timeout) Timeout will occur 12, 33 or 134 seconds (user configurable) after the last probe trigger or reset.	1.0 second maximum Note: This assumes a good radio communication link. In a poor RF environment this may rise to a maximum of 3 seconds.
Spin on Spin at 500 rev/min for 1 second minimum (6 seconds maximum).	Spin off Spin at 500 rev/min for 1 second minimum (6 seconds maximum). A timer automatically switches the probe off 90 minutes after the last trigger if it is not spun. Timer off (timeout) Timeout will occur 12, 33 or 134 seconds (user configurable) after the last probe trigger or reset.	2 seconds maximum. Note: The 2 seconds starts from the moment the spindle reaches 500 rev/min.
Shank switch on	Shank switch off	1 second maximum.

Notes:

The RMP60 will be turned on after 1 sec in all modes.

After being turned on, the RMP60 must be on for a minimum of 1 sec (7 seconds for spin option) before being turned off.

In radio on configuration (either radio on/radio off or radio on/time off) the RMP60 has a built-in hibernate mode. This saves battery life when the RMP60 is in stand-by and the RMI is un-powered (or out of range).

The RMP60 goes into hibernate mode 30 sec after the RMI is un-powered (or out of range). When in this mode, the RMP60 checks for a powered RMI every 30 secs, if the RMI is found, the RMP60 goes from hibernate mode to stand-by, ready for radio turn on.

Battery life expectancy

Typical battery reserve life

Using standard alkaline batteries at 5% usage, typically the probe will continue to operate for approximately 1 week after a low battery warning is first indicated.

Replace the batteries as soon as is practicable.

Battery life (2 x AA 1.5 V alkaline)

Rechargeable batteries: either nickel metal hydride (NiMH) or nickel cadmium (NiCd) can be used, but expect a battery life of approximately 50% of the alkaline figures given in the table below.

To achieve stated radio stand-by life, the RMP60 must be in-range of a powered partner RMI.

Battery Two AA type	Shank/spin turn on		Radio turn on		Continuous use (hours - typical)
	Stand-by life (days - typical)	5% usage 72 minutes/day (days - typical)	Stand-by life (days - typical)	5% usage 72 minutes/day (days - typical)	
Alkaline	650	100	130	65	140
Lithium Thionyl Chloride	1300	200	260	130	280

For applications requiring greater battery life, certain high capacity lithium thionyl chloride batteries can be used (3.6 V x2).

RMP60M modular system

RMP60M is a special modular version of RMP60. It enables probe inspection of part features inaccessible to RMP60, by fitting selected adaptors and extensions as shown.

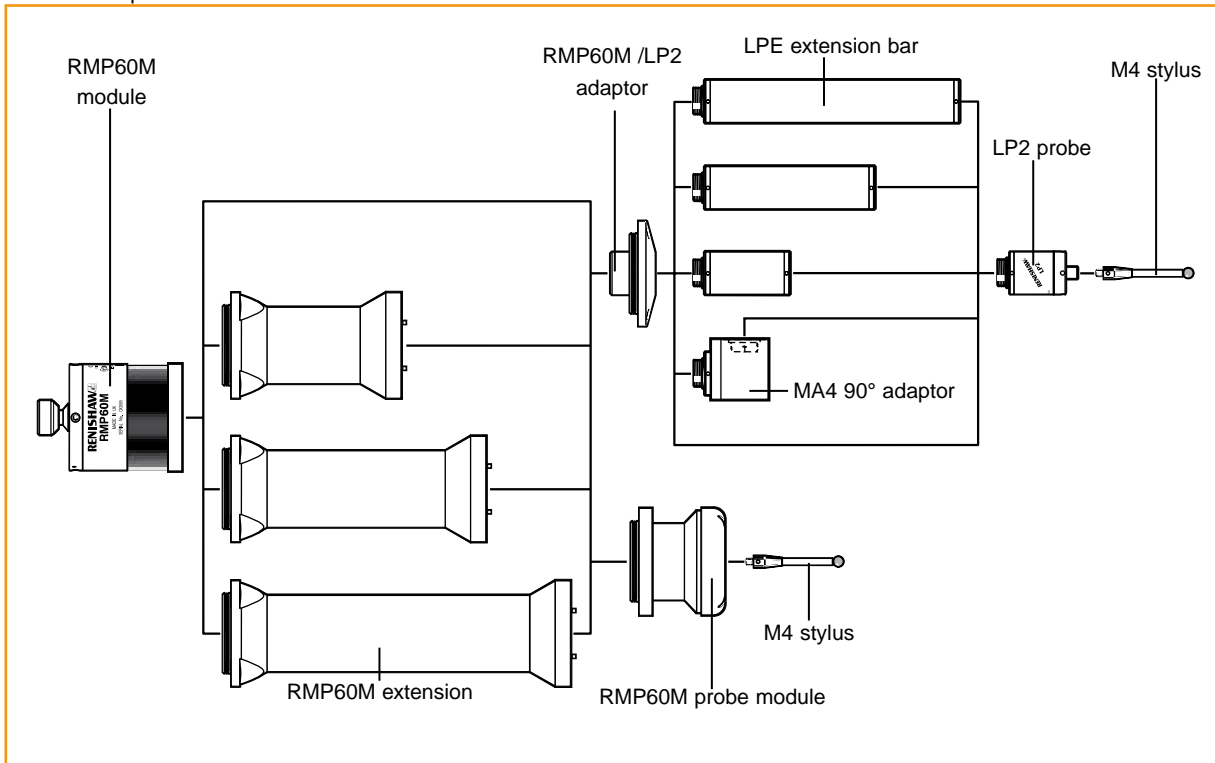

RMP60M dimensions

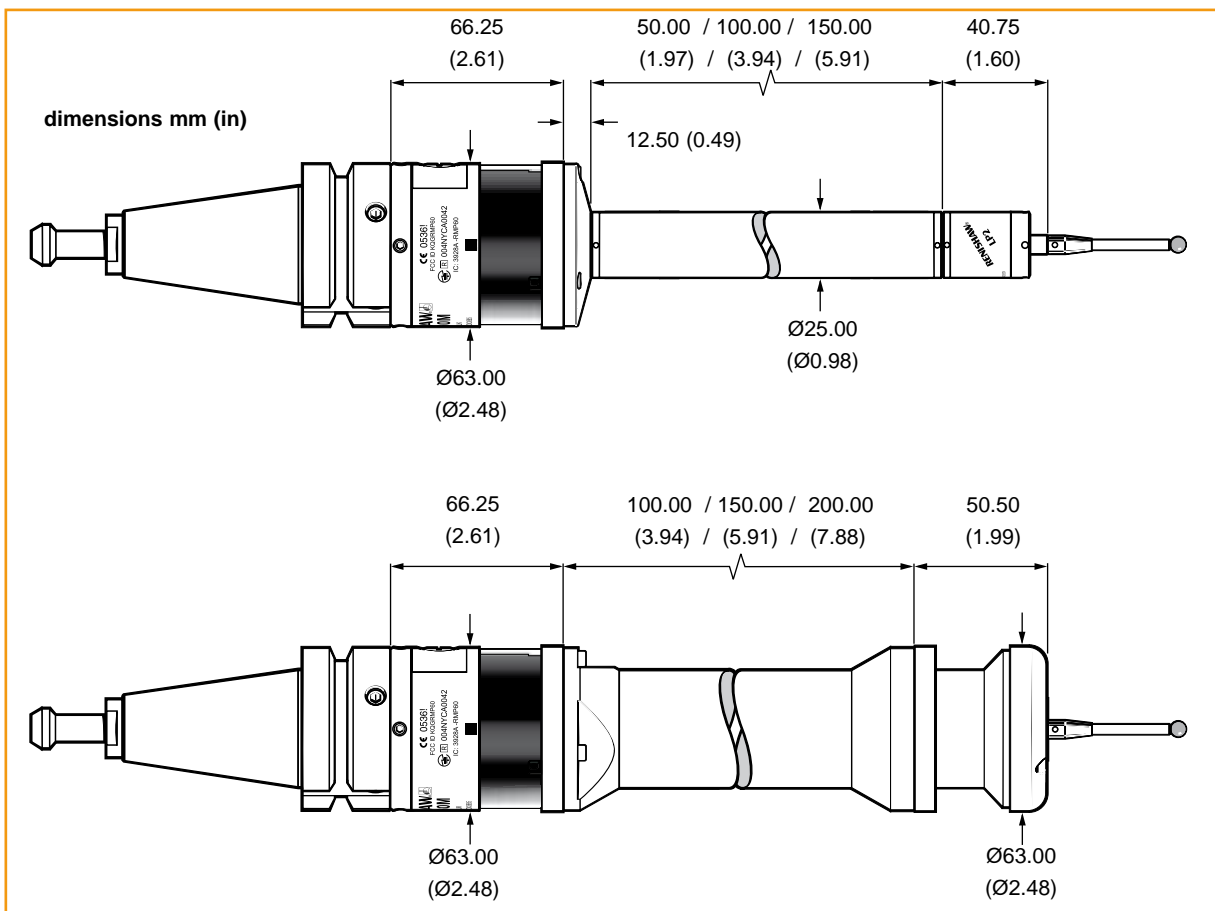

Parts list

Please quote the Part no. when ordering equipment.

Type	Part number	Description
RMP60	A-4113-0001	RMP60 probe with batteries, tool kit and quick-start guide (factory set to radio on/radio off).
RMP60 module	A-4113-1003	RMP60M probe with batteries, tool kit and quick-start guide (factory set to radio on/radio off).
Battery	P-BT03-0005	AA battery - Alkaline type supplied as standard with probe (two required).
Battery	P-BT03-0008	AA battery - Lithium thionyl chloride (two required).
Stylus	A-5000-3709	PS3-1C ceramic stylus 50 mm long with Ø6 mm ball.
Weak link kit	A-2085-0068	Weak link (Part no. M-2085-0069 x 2) and 5 mm AF spanner.
Tool kit	A-4038-0304	Probe tool kit comprising: Ø1.98 mm stylus tool, 2.0 mm AF hexagon key, 2.5 mm AF hexagon key (x 2), 4 mm AF hexagon key, and shank grub screws (x 2).
Diaphragm kit	A-4038-0302	RMP60 outer diaphragm.
Battery cassette	A-4038-0300	RMP60 battery cassette assembly.
Cassette seal	A-4038-0301	Battery cassette housing seal.
Bobbin kit	A-4038-0303	Bobbin for shank switch (supplied with shank).
RMI	A-4113-0050	RMI, side exit, with 15 m (49.2 ft) cable, tool kit and user's guide.
Mounting bracket	A-2033-0830	Mounting bracket with fixing screws, washers and nuts.
Styli tool	M-5000-3707	Tool for tightening/releasing styli.
Extension L100	A-4038-1010	RMP60M extension - 100 mm long.
Extension L150	A-4038-1027	RMP60M extension - 150 mm long.
Extension L200	A-4038-1028	RMP60M extension - 200 mm long.
Probe module	A-4038-1002	RMP60M probe module assembly.
RMP60/LP2 adaptor	A-4038-0212	RMP60M LP2 adaptor assembly.
LPE1	A-2063-7001	LPE1 extension bar - 50 mm long.
LPE2	A-2063-7002	LPE2 extension bar - 100 mm long.
LPE3	A-2063-7003	LPE3 extension bar - 50 mm long.
MA4	A-2063-7600	MA4 90° adaptor assembly.
Publications. These can be downloaded from our web site at www.renishaw.com		
RMP60 Quick start guide	A-4113-8501	Quick-start guide: for rapid set-up of RMP60, includes CD with installation guide.
Styli	H-1000-3200	Technical specification: styli and accessories.
Taper shanks	H-2000-2011	Data sheet: Taper shanks for machine tool probes.
RMI	H-2000-2123	Data sheet: RMI Radio machine interface.
MI 12	H-2000-2195	Data sheet: MI 12 interface unit.
Software	H-2000-2289	Data sheet: Probe software for machine tools.

For worldwide contact details, please visit our
 main web site at www.renishaw.com/contact

DISCLAIMER

RENISHAW HAS MADE CONSIDERABLE EFFORTS TO ENSURE THE CONTENT OF THIS DOCUMENT IS CORRECT AT THE DATE OF PUBLICATION BUT MAKES NO WARRANTIES OR REPRESENTATIONS REGARDING THE CONTENT. RENISHAW EXCLUDES LIABILITY, HOWSOEVER ARISING, FOR ANY INACCURACIES IN THIS DOCUMENT.



H - 2000 - 2122 - 04