

# ST Therma-Fuser™

## Square Thermally Powered VAV Diffuser

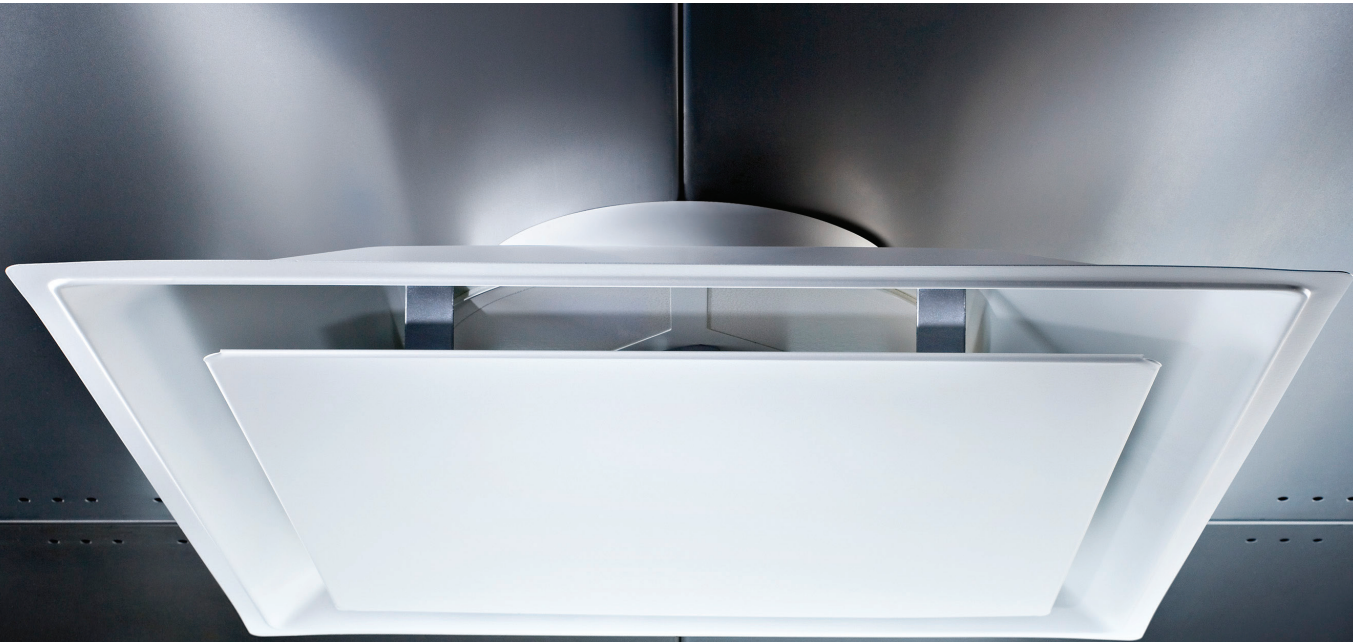

Models: **ST-HC** Separate set points for VAV heating and VAV cooling  
**ST-C** One set point for VAV cooling only



ST: Product Overview  
FORM 042.101 REV 1605

### BENEFITS AT A GLANCE.

#### INDIVIDUAL COMFORT SELECTION AND CONTROL

Every Therma-Fuser™ diffuser is a VAV zone of temperature control providing pleasing comfort in both heating and cooling. The built in thermostat senses average room air temperature from a sample of air induced into the unit. It controls air flow to precisely match the comfort requirements of the room or portion of the room served. Occupants breathe easier knowing that their personal temperature choice will not be changed by someone else.

#### EASY LOW COST INSTALLATION AND BALANCING

No special skills or equipment are required to install Therma-Fuser VAV—just connect the supply air duct. Expensive electrical or pneumatic connections and complicated controls are eliminated. Minimum flow stop changes are easily dialed in. Opens for balancing with one hand without opening the appearance panel. Maintenance and recalibration are eliminated, even over the long term, due to the dependability of the durable wax motor.

#### ONLY THERMA-FUSER™ VAV OFFERS THESE BENEFITS

- Separate temperature set points for VAV heating and VAV cooling.
- Superior air distribution, longer throws, no dumping, more entrainment, even temperature distribution, higher ADPI\* and better room air change effectiveness.
- Lowest cost per zone of control.
- Lowest energy VAV terminal — green VAV.
- Low to no maintenance —10 year warranty.
- Easily adapts to office changes.

\*ADPI (Air Diffusion Performance Index)

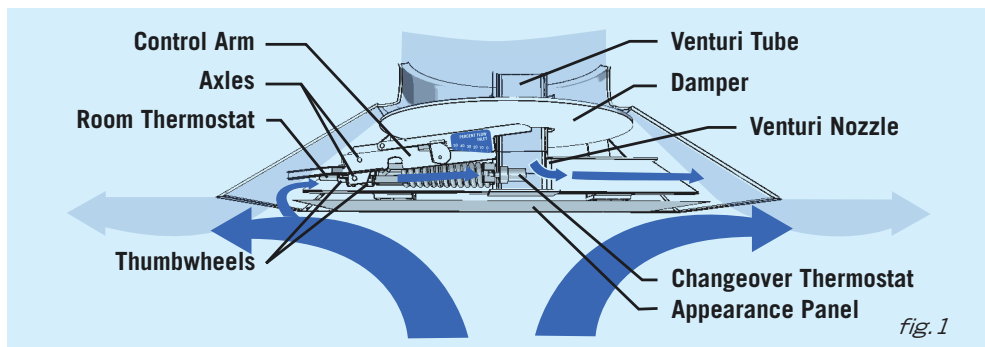

### HOW IT WORKS

Model ST Therma-Fuser diffusers are 24" (600mm) square ceiling diffusers with built-in temperature controls and VAV damper. The round damper moves up to close and down to open, metering air flow (warm or cool) into the room in response to room temperature. The damper is mechanically positioned by a thermostat/actuator which is both a room thermostat and damper motor.

The room thermostat/actuator is a large brass cylinder containing a petroleum based wax. The wax melts and expands when heated, pushing against a fixed piston which moves the thermostat outward. A heavy spring pulls the thermostat inward when the wax cools and contracts. Thumbwheels on the room thermostat push the two offset axles of the control arm to move the damper up or down.

### ROOM AIR SENSING

As with all diffusers, air circulates around the room in a circular motion. Secondary air rises under the diffuser, passes beneath the appearance panel and entrains with the primary air at the outside edge of the diffuser. (fig. 1) This secondary air best represents average room temperature.

To monitor average room temperature, a continuous sample of secondary air is drawn around the appearance panel past the room thermostat and through the channel. This is accomplished by feeding primary air through a nozzle in the side of the venturi tube. Primary air blowing through the nozzle creates just enough vacuum to draw some secondary air around the appearance panel, over the thermostat and out the other side. A properly applied ST will hold the

room average within 1.5°F/0.9°C of the temperature selected.

### COOLING MODE

In the cooling mode the damper opens on a rise in room temperature. As the room warms, the wax in the room thermostat melts and expands. This pushes the thermostat and cooling thumbwheel outward away from the lower axle of the control arm. The control arm then pivots down around the upper control axle, opening the damper allowing more supply air to enter the room. When the room cools, the wax contracts, the spring pulls the room thermostat inward and the cooling thumbwheel pushes the lower control axle inward. This pivots the control arm up closing the damper.

### CHANGEOVER (ST-HC ONLY)

Changeover between the cooling and heating modes is determined by supply air temperature. A second large thermostat/actuator located at the bottom of the venturi tube senses supply air temperature. Warming the changeover thermostat changes the ST-HC to the heating mode by indexing the room thermostat outward. As a result both thumbwheels are indexed outward. This moves the cooling thumbwheel away from the control axles while the heating thumbwheel is moved toward the control axles.

Changeover from cooling to heating begins at supply air temperature 76°F/24.5°C and completes at 80°F/26.5°C. Changeover back to cooling begins at 72°F/22°C and completes at 68°F/20°C. During changeover the damper is closed or at minimum flow. The changeover control rod moves under the control arm, first closing the damper and then opening it.

### HEATING MODE (ST-HC ONLY)

In the heating mode, the damper opens on a drop in room temperature. As the room cools, the wax in the room thermostat contracts and the spring pulls the room thermostat inward. This pushes the heating thumbwheel inward away from the upper control axle. The control arm then pivots down around the lower control axle, opening the damper allowing more supply air into the room.

### ADJUSTING SET POINTS

Heating and cooling set points are separately adjusted by turning the heating and cooling thumbwheels. (fig. 2) Align the outside of each thumbwheel with its respective temperature scale. Each set point can be adjusted between 70°F/21°C and 78°F/26°C. Both are factory set at 74°F/23°C. (The model ST-C has only one thumbwheel).

If the cooling thumbwheel is tight when the room is cool, continue to turn the thumbwheel and pull the changeover close rod outward to relieve the tightness.

### OPEN FOR BALANCING

To open, push the balancing lever to the right and up. (fig. 3) To close, push the balancing lever down until it latches.

### ADJUSTING MINIMUM FLOW

Turn dial until the desired minimum flow on the scale intersects with the lower metal piece. (fig. 4)

### SYSTEM DESIGN

The best control for heating/cooling units supplying air to VAV terminals is a discharge thermostat which maintains a constant supply air temperature. With DX equipment these are a high and low limit. Use a room thermostat for changeover between heating and cooling modes. For hybrid systems (part VAV and part constant volume) control the heating/cooling supply unit with a thermostat in one of the rooms with a constant volume diffuser, preferably the space with the greatest load. For both VAV and hybrid systems, the fan should run continuously.

The constant discharge velocity of Therma-Fuser diffusers at varying air flow provides good room circulation which reduces stratification. Keeping heating supply air temperatures as low

### DIMENSIONS

| Inlet Designation | OD            |        |
|-------------------|---------------|--------|
|                   | Inches ± 1/16 | mm ± 3 |
| 6                 | 5 15/16       | 150    |
| 8                 | 7 15/16       | 200    |
| 10                | 9 15/16       | 250    |
| 12                | 11 15/16      | 300    |

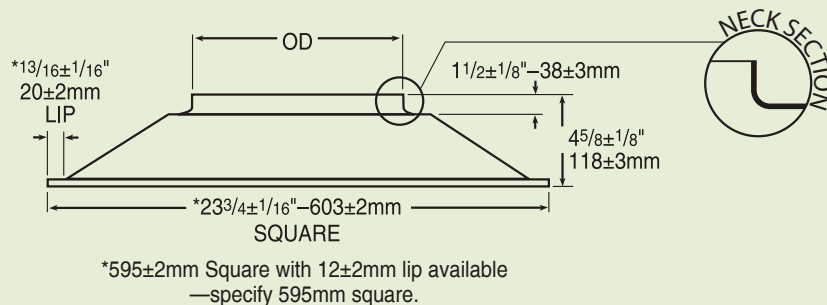

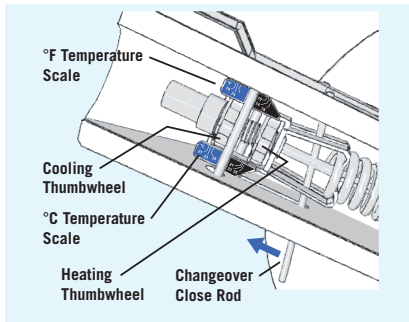

fig.2

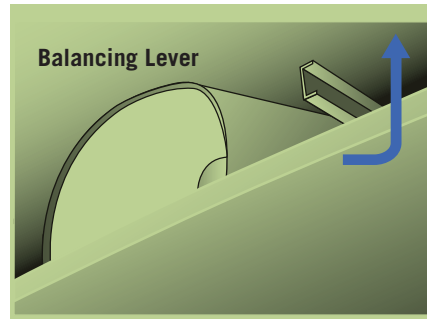

fig.3

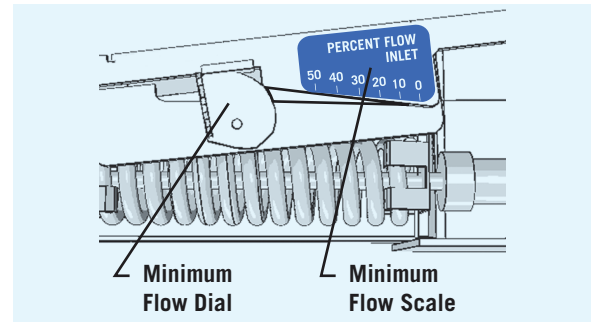

fig.4

as possible will further reduce room air stratification to a negligible level.

Static pressure at the inlet of the Therma-Fuser diffuser should be between .05"wg/12Pa and .25"wg/62Pa, at full and partial air flows. Static pressure below .05"wg/12Pa will result in low air flow and less induction. Above .25"wg/62Pa, Therma-Fuser diffusers operate well but excessive noise may result. Use minimum flow settings where tight shut off is not needed.

If the system turns down more than 30%, static pressure should be controlled. Included in the options for static pressure control are fan speed control and modulating bypass dampers. Modulating zone dampers are recommended where several zones share a higher pressure duct or riser.

When designing ducts, if Therma-Fuser diffusers are to deliver nominal volume at inlet SP of .15"wg/37Pa and if a maximum SP of .25"wg/62Pa is to be held for quiet operation, size the duct for a maximum pressure drop of .1"wg/25Pa between the first and last takeoff.

Manual balancing dampers should be used at the takeoff for each diffuser. Manual balancing dampers may not be required with ducts designed to Acutherm specifications.

Because Therma-Fuser diffusers control room temperature by sensing room air induced up the center of the

space, care should be taken not to disturb room air induction and entrainment. For example, location next to walls or dropped lights results in the reflection of primary air back at the Therma-Fuser diffuser. Relocate either the Therma-Fuser diffuser or the light.

Acutherm has "how to" system design brochures for almost every ducted air system. For specific recommendations refer to the brochure for your system.

### GUIDE SPECIFICATION

(Suitable for Section 23 36 16 Variable-Air-Volume Units of the CSI MasterFormat) *Material in italics applies only to model ST-HC. Delete the italics for model ST-C.*

#### 2.2 Thermally Powered VAV Diffusers

A. Thermally powered variable air volume diffusers shall be Therma-Fuser™ model ST manufactured by Acutherm, Hayward CA.

B. Thermally powered VAV diffusers shall be a complete VAV terminal and thermostat self-contained in a nominal 24"x24" / 600mm square diffuser. They shall be thermally powered with one room thermostat/actuator and one changeover thermostat/actuator. External wiring or pneumatics shall not be allowed.

C. The VAV diffusers shall have a thumbwheel and temperature scale to adjust the cooling set point *and a separate thumbwheel and temperature scale for the heating set point.* The adjustment shall be right above the hinged

appearance panel and shall not require tools. Each set point shall be separately adjustable between 70°F/21°C and 78°F/26°C. The initial set point shall be factory set at 74°F/23°C.

D. In the cooling mode the VAV diffusers shall open on a rise in room temperature *and in the heating mode they shall close on a rise in room temperature. The changeover thermostat shall be factory installed and adjusted to engage the heating mode when the supply air temperature rises above 80°F/27°C and return to the cooling mode when the supply air temperature falls below 68°F/20°C. During changeover the diffuser shall close or if a minimum flow is set, go to the minimum.* Nothing, including the changeover mechanism, shall extend above the inlet of the diffuser.

E. All VAV diffusers shall have a dial and scale to adjust minimum flow between 5 cfm/2.4 l/s and 50% of maximum flow without tools. Minimum flow shall be factory set at 10%. A fixed maximum flow stop shall be factory set for the full open air flow of the specified inlet size.

F. All VAV diffusers shall have a lever which will open the damper for balancing without tools. The balancing lever shall be accessible from the outside of the diffuser without folding down the appearance panel or removing any part of the diffuser.

G. All VAV diffusers shall warrant that the diffuser shall be free from defects in materials and workmanship for a period of ten years from date of shipment.

PERFORMANCE GUIDE in I-P UNITS

| Nominal Inlet | Inlet Diameter in | Inlet Static Pressure in wg | Maximum Flow cfm | Maximum Flow                                     |      | 25% Maximum Flow                                 |      |
|---------------|-------------------|-----------------------------|------------------|--|------|--|------|
|               |                   |                             |                  | Throw - Feet*<br>@ v <sub>i</sub> =50/100/150fpm | †NC  | Throw - Feet*<br>@ v <sub>i</sub> =50/100/150fpm | †NC  |
| 6"            | 5 15/16"          | 0.05                        | 105              | 3/1<1  | < 15 | 1/<1/<1  | < 15 |
|               |                   | •0.09                       | 141              | 4/2/1  | 17   | 2/<1/<1  | < 15 |
|               |                   | 0.10                        | 150              | 4/2/1  | 17   | 2/<1/<1  | < 15 |
|               |                   | 0.15                        | 180              | 5/3/1  | 25   | 3/1/<1   | < 15 |
|               |                   | 0.20                        | 210              | 6/4/2  | 29   | 4/1/1  | < 15 |
|               |                   | 0.25                        | 240              | 7/5/3  | 32   | 4/2/2  | 21   |
| 8"            | 7 15/16"          | 0.05                        | 165              | 5/2/1  | < 15 | 2/1/<1   | < 15 |
|               |                   | 0.10                        | 235              | 7/3/2  | 18   | 3/1/<1   | < 15 |
|               |                   | •0.12                       | 255              | 7/3/2  | 21   | 3/1/<1   | 16   |
|               |                   | 0.15                        | 285              | 8/4/3  | 25   | 4/1/1  | 17   |
|               |                   | 0.20                        | 330              | 9/5/3  | 30   | 4/2/1  | 20   |
|               |                   | 0.25                        | 380              | 9/6/4  | 34   | 5/3/2  | 25   |
| 10"           | 9 15/16"          | 0.05                        | 255              | 6/3/2  | < 15 | 3/1/<1   | < 15 |
|               |                   | 0.10                        | 360              | 8/5/2  | 23   | 3/1/<1   | < 15 |
|               |                   | •0.13                       | 408              | 9/6/3  | 26   | 4/1/1  | 16   |
|               |                   | 0.15                        | 440              | 9/6/4  | 28   | 4/2/1  | 17   |
|               |                   | 0.20                        | 510              | 10/7/5   | 32   | 5/3/2  | 22   |
|               |                   | 0.25                        | 570              | 11/8/6   | 36   | 6/4/3  | 26   |
| 12"           | 11 15/16"         | 0.05                        | 335              | 8/6/2  | < 15 | 4/1/<1   | < 15 |
|               |                   | 0.10                        | 470              | 10/7/4   | 25   | 5/2/1  | < 15 |
|               |                   | •0.15                       | 580              | 11/8/5   | 31   | 6/2/1  | 21   |
|               |                   | 0.17                        | 616              | 11/9/6   | 33   | 6/2/1  | 23   |
|               |                   | 0.20                        | 670              | 12/10/7  | 35   | 7/3/2  | 27   |
|               |                   | 0.25                        | 740              | 13/11/9  | 38   | 8/5/2  | 31   |

- Denotes 750 fpm / 3.81 m/s inlet velocity.
- \* Throw data is for air 20°F/11°C lower than room temperature. Throws for isothermal air are 40 to 50% greater.
- † NC based on L<sub>w</sub>(10<sup>-12</sup> watts reference) -10db
- Tested in accordance with ANSI/ASHRAE 70-1991, ANSI S12.31, ARI 890-2001, ISO 5219 and ISO 3741.
- Ratings independently verified by Inchcape Testing Services, ETL Testing Laboratories.
- When bypassing air into the plenum at the diffuser with Acutherm R-Rings, throws may be as low as 90% of, and the NC 2db higher than, those listed in the performance chart.
- When blocking for direction with the Acutherm directional baffles, the air volume for a given static pressure is reduced from maximum flow listed in the performance chart by:

| Inlet Designation | Reduction |                |              |
|-------------------|-----------|----------------|--------------|
|                   | 3-Way     | 2-Way Opposite | 2-Way Corner |
| 6                 | 0.99      | 1.00           | 0.99         |
| 8                 | 0.97      | 0.87           | 0.86         |
| 10                | 0.88      | 0.72           | 0.75         |
| 12                | 0.85      | 0.77           | 0.65         |



PERFORMANCE GUIDE in SI (METRIC) UNITS

| Inlet Designation | Nominal Inlet Dia. mm | Inlet Static Pressure Pa | Maximum Flow |                   | Maximum Flow Throw (m)*@v <sub>t</sub> = |         |         |      | 25% Maximum Flow Throw (m)*@v <sub>t</sub> = |         |         |      |
|-------------------|-----------------------|--------------------------|--------------|-------------------|--|---------|---------|------|--|---------|---------|------|
|                   |                       |                          | L/s          | m <sup>3</sup> /h | .25 m/s                                  | .50 m/s | .75 m/s | †NC  | .25 m/s                                      | .50 m/s | .75 m/s | †NC  |
| 6"                | 150                   | 10                       | 45           | 164               | 0.9                                      | 0.3     | 0.3     | < 15 | 0.2  | < 0.3   | < 0.3   | < 15 |
|                   |                       | 20                       | 62           | 225               | 1.1                                      | 0.5     | 0.3     | 16   | 0.5  | < 0.3   | < 0.3   | < 15 |
|                   |                       | •30                      | 77           | 276               | 1.4                                      | 0.8     | 0.3     | 20   | 0.7  | < 0.3   | < 0.3   | < 15 |
|                   |                       | 40                       | 88           | 317               | 1.6                                      | 1.0     | 0.4     | 26   | 1.0  | 0.3     | < 0.3   | < 15 |
|                   |                       | 50                       | 99           | 358               | 1.8                                      | 1.2     | 0.6     | 29   | 1.2  | 0.3     | 0.3     | < 15 |
|                   |                       | 60                       | 111          | 399               | 2.1                                      | 1.5     | 0.9     | 31   | 1.2  | 0.6     | 0.4     | 20   |
| 8"                | 200                   | 10                       | 71           | 257               | 1.4                                      | 0.6     | 0.3     | <15  | 0.6  | 0.3     | < 0.3   | < 15 |
|                   |                       | 20                       | 98           | 353               | 1.9                                      | 0.8     | 0.5     | 17   | 0.8  | 0.3     | < 0.3   | < 15 |
|                   |                       | •30                      | 121          | 434               | 2.3                                      | 1.1     | 0.7     | 21   | 1.1  | 0.3     | < 0.3   | 16   |
|                   |                       | 40                       | 139          | 501               | 2.5                                      | 1.3     | 0.9     | 26   | 1.2  | 0.4     | 0.3     | 18   |
|                   |                       | 50                       | 156          | 563               | 2.8                                      | 1.6     | 0.9     | 30   | 1.2  | 0.6     | 0.3     | 20   |
|                   |                       | 60                       | 175          | 631               | 2.8                                      | 1.8     | 1.2     | 33   | 1.5  | 0.9     | 0.6     | 24   |
| 10"               | 250                   | 10                       | 111          | 399               | 1.6                                      | 0.8     | 0.4     | < 15 | 0.9  | 0.3     | < 0.3   | < 15 |
|                   |                       | 20                       | 150          | 542               | 2.2                                      | 1.3     | 0.6     | 20   | 0.9  | 0.3     | < 0.3   | < 15 |
|                   |                       | •30                      | 185          | 668               | 2.6                                      | 1.7     | 0.9     | 25   | 1.1  | 0.4     | 0.3     | 16   |
|                   |                       | 40                       | 215          | 774               | 2.8                                      | 1.9     | 1.3     | 29   | 1.3  | 0.5     | 0.4     | 18   |
|                   |                       | 50                       | 241          | 869               | 3.1                                      | 2.2     | 1.6     | 32   | 1.5  | 0.8     | 0.6     | 22   |
|                   |                       | 60                       | 264          | 951               | 3.3                                      | 2.4     | 1.8     | 35   | 1.8  | 1.2     | 0.9     | 25   |
| 12"               | 300                   | 10                       | 146          | 525               | 2.3                                      | 1.8     | 0.6     | < 15 | 1.2  | 0.3     | < 0.3   | < 15 |
|                   |                       | 20                       | 197          | 709               | 2.8                                      | 2.0     | 1.0     | 21   | 1.4  | 0.5     | 0.3     | < 15 |
|                   |                       | 30                       | 243          | 876               | 3.2                                      | 2.3     | 1.4     | 27   | 1.7  | 0.6     | 0.3     | 17   |
|                   |                       | •40                      | 283          | 1019              | 3.4                                      | 2.6     | 1.7     | 32   | 1.9  | 0.7     | 0.4     | 22   |
|                   |                       | 50                       | 317          | 1141              | 3.7                                      | 3.1     | 2.2     | 35   | 2.2  | 1.0     | 0.5     | 27   |
|                   |                       | 60                       | 343          | 1237              | 3.9                                      | 3.3     | 2.7     | 37   | 2.4  | 1.3     | 0.5     | 30   |

- All SI (Metric) ratings are soft conversion from I-P ratings
- Denotes 750 fpm / 3.81 m/s inlet velocity.
- \* Throw data is for air 20°F/11°C lower than room temperature. Throws for isothermal air are 40 to 50% greater.
- † NC based on L<sub>w</sub>(10<sup>-12</sup> watts reference) -10db
- Tested in accordance with ANSI/ASHRAE 70-1991, ANSI S12.31, ARI 890-2001, ISO 5219 and ISO 3741.
- Ratings independently verified by Inchcape Testing Services, ETL Testing Laboratories.
- When bypassing air into the plenum at the diffuser with Acutherm R-Rings, throws may be as low as 90% of, and the NC 2db higher than, those listed in the performance chart.
- When blocking for direction with the Acutherm directional baffles, the air volume for a given static pressure is reduced from maximum flow listed in the performance chart by:

| Inlet Designation | Reduction |                |              |
|-------------------|-----------|----------------|--------------|
|                   | 3-Way     | 2-Way Opposite | 2-Way Corner |
| 6                 | 0.99      | 1.00           | 0.99         |
| 8                 | 0.97      | 0.87           | 0.86         |
| 10                | 0.88      | 0.72           | 0.75         |
| 12                | 0.85      | 0.77           | 0.65         |



# ST Therma-Fuser™ Square Thermally Powered VAV Diffuser

## TEN YEAR WARRANTY

Acutherm warrants that its ST diffuser, exclusive of any options and accessories (whether factory or field installed) shall be free from defective material or workmanship for a period of ten (10) years from the date of shipment and agrees to repair or replace, at its option, any parts that fail during said ten (10) year period due to any such defects which would not have occurred had reasonable care and proper usage and all parts and controls remain unaltered. Acutherm makes NO WARRANTY OF MERCHANTABILITY OF PRODUCTS OR OF THEIR FITNESS FOR ANY PURPOSE OR ANY OTHER EXPRESS OR IMPLIED WARRANTY WHICH EXTENDS BEYOND THE LIMITED WARRANTY ABOVE. ACUTHERM'S LIABILITY FOR ANY AND ALL LOSSES AND DAMAGES RESULTING FROM DEFECTS SHALL IN NO EVENT EXCEED THE COST OF REPAIR OR REPLACEMENT OF PARTS FOUND DEFECTIVE UPON EXAMINATION BY ACUTHERM. IN NO EVENT SHALL ACUTHERM BE LIABLE FOR INCIDENTAL, INDIRECT OR CONSEQUENTIAL DAMAGES OR DAMAGES FOR INJURY TO PERSONS OR PROPERTY. Acutherm shall not be responsible for freight to or from its plant in connection with the inspection, repair or replacement of parts under the terms of this limited warranty nor for cost of removal or installation.

Protected by U.S. Patents 6,736,326 & 6,857,577. Patents pending in other countries.

## ACUTHERM PRODUCT GUIDE

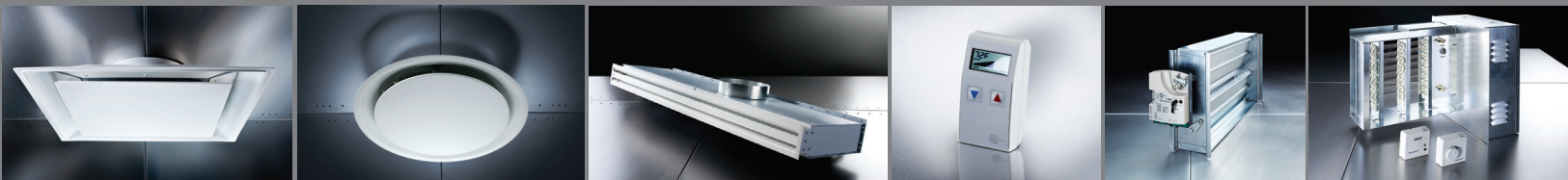

Square VAV Diffusers

Round VAV Diffusers

Linear VAV Diffusers

Accessories

Pressure Control

Temperature Control

## PRODUCT INFORMATION DESCRIPTION Use the following model number nomenclature to order Therma-Fuser™ diffusers, options and accessories.

### Product

| (1)<br>Model | (2)<br>Type | (3)<br>Size |
|--------------|-------------|-------------|
| ▶ <b>ST</b>  |             |             |

### Product

1. Model: **ST** – Square Therma-Fuser diffuser
2. Type: **C** VAV cooling only or **HC** VAV heating and cooling
3. Size: **6, 8, 10,** or **12** inch inlet

### Options

| (1)<br>Remote Adjust   | (2)<br>R-Ring        | (3)<br>Insulation  | (4)<br>Security Hanger |
|------------------------|----------------------|--------------------|------------------------|
| ▶                      |                      |                    |                        |
| (5)<br>Sheared Housing | (6)<br>Blow Patterns | (7)<br>Silk Screen | (8)<br>Sensor          |
| ▶                      |                      |                    |                        |

### Options

1. Remote Adjust: **DA1** and **DA1M** for Digital Wall Adjuster or **WA1M** for Wireless Wall Adjuster
2. R-Ring: **Rx** for bypass relief ring where 'x' is **6, 8** or **10** inch inlet
3. Insulation: **I** for attic side insulation
4. Security Hanger: **H**
5. Sheared Housing: **595** for 600mm metric grid ceilings, **T1** for 23<sup>3/16</sup>" and **T2** for 22<sup>3/4</sup>"
6. Blow Patterns: **STD3** for three way blow, **STD2** for two way opposite, and **STD2C** for two way corner
7. Sensor: **AS** for DSMC or for 3rd party

### Accessories

| (1)<br>Ceiling Frame |
|----------------------|
| ▶                    |

### Accessories

1. Ceiling Frame: **TFHD** for hard ceiling, **TF4DB** for 4" drop box, **TF1DB** for 1<sup>7/16</sup>" drop box, **TFSP** for spline, **TFT1** for regular 9/16" T-bar, **TFT2** for regular 1" T-bar, and **TFAL** for air lifter (no ceiling)

## AVAILABLE ONLINE

Access digital brochures, CAD files, performance data and more!

[www.acutherm.com](http://www.acutherm.com)

## CALL US

Talk to our customization and specification experts

+1 800 544 1840



## EMAIL SUPPORT

Send us your questions and we'll get you the answers you need.

[info@acutherm.com](mailto:info@acutherm.com)