

Appendix 5 - Making Waste Work: A Toolkit

# How-to guides 1-12

How to turn waste material into useful products

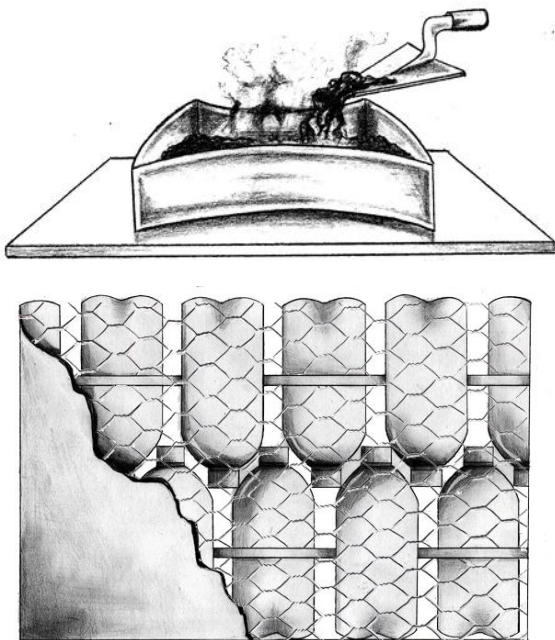

## How-to guides 1-12

Part of

**Making Waste Work: A Toolkit**  
for community waste  
management in low and middle  
income countries

Zoë Lenkiewicz and Mike Webster  
Illustrated by Susan Hatfield  
October 2017

[wasteaid.org.uk/toolkit](http://wasteaid.org.uk/toolkit)

This toolkit has been produced by WasteAid UK  
with funding from the Chartered Institution of Wastes Management





WasteAid UK is a charity working to make an impact on the global waste emergency by:

- Partnering with local organisations to improve the health, environment and livelihoods of people without waste services.
- Building the skills of local people to deliver practical solutions to the waste management crisis in their own communities.
- Raising awareness of the benefits of proper waste management and campaigning for greater change.

[www.wasteaid.org.uk](http://www.wasteaid.org.uk)



CIWM (Chartered Institution of Wastes Management) is the leading professional body for the resource and waste management sector, representing around 6,000 individuals in the UK, Ireland and overseas. It awards the title of Chartered Waste Manager to qualifying members.

The objectives of the CIWM are to advance the scientific, technical and practical aspects of wastes and resource management worldwide for the safeguarding of the natural environment, to promote education, training, and research in wastes and resource management, and the dissemination of knowledge of the topic; and to strive to achieve and maintain the highest standards of best practice, technical competence and conduct by all its members.

[www.ciwm.co.uk](http://www.ciwm.co.uk)

#### **Creative Commons**

Under this licence, our work may be shared freely. This provides the freedom to copy, distribute and transmit this work on to others, provided WasteAid UK and CIWM are credited as the authors, text and images are unaltered. This work must not be resold or used for commercial purposes. These conditions can be waived under certain circumstances with the written permission of WasteAid UK. For more information about this licence go to <http://creativecommons.org/licenses/by-nc-nd/3.0/>

#### **Disclaimer**

The information in this Toolkit and associated How-to guides is provided in good faith and is intended as an indicative guide to the processes and activities referred to only, based on information provided by currently active operators and practitioners. It should not be taken as a definitive guide to the activities referred to, and should not be used as a substitute for undertaking a full site-specific health and safety risk assessment. WasteAid and CIWM recommend always undertaking a full feasibility and environmental and health and safety risk assessment, based on the specific conditions applying to the community, waste, and site in question. WasteAid and CIWM do not accept any legal responsibility for any errors, omissions or misleading statements, or for any injury or loss resulting from the use of or reliance upon the processes outlined in this Toolkit and associated How-to guides. WasteAid and CIWM are not responsible for, and cannot guarantee the accuracy of, information on sites they do not manage, nor should the inclusion of a hyperlink be taken in itself to mean the endorsement of the site, the site owner or any specific content to which it points.

**C**

**Be inspired:**

**How to transform waste  
into a resource**

## Contents

### VOLUME II

Introduction .....	1
1. How to measure your waste .....	2
2. How to transform woody waste to fuel briquettes .....	13
3. How to convert organic waste into biogas .....	25
4. How to transform fish waste into animal feed .....	46
5. How to turn organic waste into compost .....	52
6. How to turn organic waste into compost using worms.....	57
7. How to prepare plastics to sell to market.....	63
8. How to transform plastic waste into paving tiles .....	74
9. How to turn mixed plastic waste and bottles into ecobricks.....	81
10. How to crochet film plastic into bags and mats.....	85
11. How to collect waste safely and efficiently .....	90
12. How to design and operate a basic waste disposal site .....	95

#### Acknowledgements

Professor David C Wilson, Pat Jennings and Tina Benfield at CIWM; David Leeke for technical support, online development and fieldwork; Ed Cooke and Resource Futures for background research and fieldwork; The Arkleton Trust and participants at the WasteAid seminar in The Gambia April 2017 for helpful advice, comments and additions; Isatou Ceesay and the Women's Initiative The Gambia for the charcoal briquette and crocheting technologies; Pierre Kamsouloum of Cameroon for the plastic tiles technology; Petra Röhr-Rouendaal for additional illustrations from the book *Where There Is No Artist*; Joyce Lockard for the briquetting without a press technique; USAid for waste collection and disposal advice; Brian McCarthy, Adam Read, Sophie van den Berg, Mansoor Ali, Jane Gilbert, Adam Flores, Danladi Yunana, Alexander Kumi-Larbi, Fiona Ross, David Fulford and other reviewers; and all CIWM members and WasteAid supporters.

## Introduction

Part A of this toolkit discussed the challenges and dangers posed by unmanaged waste, and the benefits of dealing with waste as a *resource*. Part B discussed the common waste materials, the products that can be made from them, and how to set up a small waste processing business.

Part C: Be inspired contains How-to guides to inspire you to transform waste into useful products. The waste materials, technologies and processes described in this toolkit vary from country to country. The How-to guides presented here are intended to inspire and enable you to develop and operate safely your own processes, suited to your geographic area and waste materials.

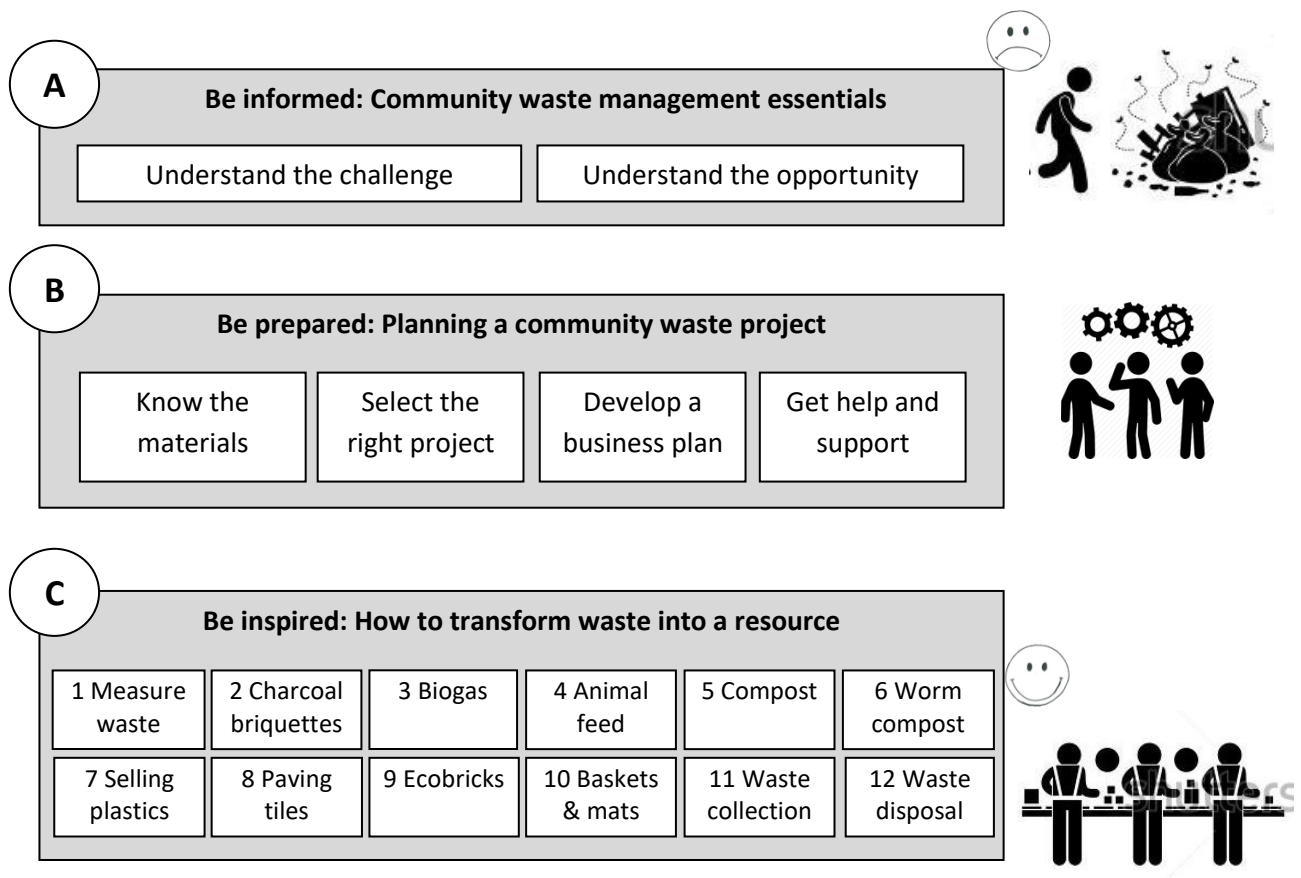

## 1. How to measure your waste

You can find out what materials are available in the waste by carrying out a detailed waste audit.

**Summary:** A waste audit (sometimes called a *waste composition analysis*) will tell you what materials are available in the waste, and how much of each material is available (see *Making Waste Work*, chapter 7).

**Benefits:** A waste audit is a simple process that involves sorting and weighing the waste materials. Once you know what materials are in the waste, and in what quantities, you can best decide how to manage it (see *Making Waste Work*, chapter 8).

You will need to plan and prepare for your waste audit, making sure you have considered everything in the checklist below. Proper planning will help your waste audit go smoothly, and means you can replicate it at a later date or a different site and compare the results.

<b>Where will you get your waste from?</b>	It will probably be impossible to measure all the waste in your community so you will need to take samples. Think about where you will collect your samples and whether this is representative of the waste produced in your community. If you collect waste from the dumpsite, many recyclable materials that can be sold may have already been removed by householders and people scavenging for materials to sell. So if you want to know about <b>everything</b> that is in the waste, before anything is removed, you may have to collect direct from houses and businesses.
<b>Safety</b>	Think about what you might find in the waste and how it could harm you (see <i>Making Waste Work</i> , chapter 4.6). Find a safe place to do the audit.
<b>Seasonality</b>	The waste might change throughout the year, as events and seasonal changes affect the amount and types of waste produced. Rain will make some materials heavier and not others.
<b>Recording the information</b>	Design a form and spreadsheet for recording in advance.
<b>Setting up your site</b>	Think about the collecting, sorting and weighing equipment you will need. Is there shade to work in and water to wash hands with? Do you need a secure area for locking up your equipment?
<b>Managing and analysing your data</b>	Once you have the data, you can transfer it onto a spreadsheet. What you can do with your data depends on how much analysis you have done.
<b>Sharing your results</b>	Think about who you want to share your results with – there is no point producing a report that just sits on the shelf.

Figure 1-1: Checklist to use when preparing for a waste audit.

## Comparing waste at different times and places

If you are likely to want to compare waste at different times and places, use a standard approach. The method described here is from a UNEP/IETC publication<sup>1</sup> and should be used as a guide. You might choose to use more or fewer categories, but be consistent if you are planning to do any more audits in the future. The most important thing is to be consistent with your method and keep a record so you can compare results.

It is impractical to audit all the waste from a community, town or city; but sampling the waste over a period of time will give you a good idea of the amounts of different materials available. For example, you might take 25 samples, each of 100 kg, over a five-day period<sup>2</sup>.

<b>Paper &amp; cardboard</b>	1. Newspaper 2. Cardboard/boxboard 3. Magazines/catalogues 4. Office paper 5. Other/miscellaneous paper
<b>Glass</b>	6. Clear containers 7. Green containers 8. Amber containers 9. Remainder/composite glass
<b>Metal</b>	10. Tin/steel containers 11. Aluminium containers 12. Other ferrous metal 13. Other non-ferrous metal 14. Major appliances
<b>Plastics</b>	15. Clear PET bottles/containers 16. Green PET bottles/containers 17. Amber PET bottles/containers 18. HDPE containers 19. Film plastics 20. Other plastics
<b>Textiles</b>	21. Textiles
<b>Organics</b>	22. Food waste 23. Garden waste 24. Agricultural waste 25. Abattoir waste 26. Remainder/composite organics
<b>Construction &amp; demolition material</b>	27. Concrete 28. Lumber 29. Remainder/composite C&D
<b>Hazardous wastes</b>	30. Paint 31. Hazardous materials 32. Biomedical 33. Batteries 34. Oil filters 35. Remainder/composite waste
<b>Other waste</b>	36. Electrical and electronic equipment 37. Tyres 38. Furniture 39. Ceramics 40. Other

Figure 1-2: Suggested categories for a waste audit, as used by the UNEP/IETC.

<sup>1</sup> UNEP/IETC (2009). *Developing Integrated Solid Waste Management Plan, Volume 1, Waste Characterisation and Quantification with Projections for Future*.

<sup>2</sup> If the waste is very dry and/or contains a lot of plastic, you may want to reduce the sample size to 50kg but it is important to be consistent.

### Finding a suitable place for a waste audit

Think about how you will transport people to the site, and how you will collect and transport equipment each day. If you are sampling the waste from a dumpsite, choose an area close to the entrance so that waste can be taken as it arrives at the site. It is better to work with fresh waste because it will be less smelly and easier to separate into different categories.

Choose a place that is flat and shaded to ensure as pleasant and safe working conditions as possible. If it is likely to rain, use some sort of shelter (like a gazebo or sheet) to keep the people and the waste dry.

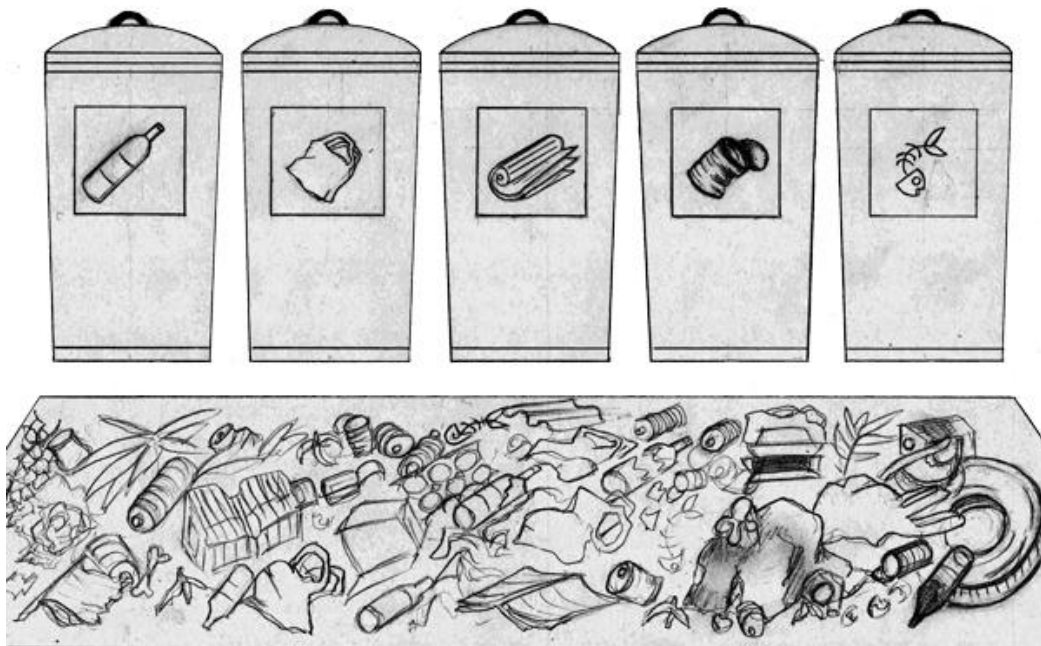

Figure 1-3: Find a flat, shaded location close to the dumpsite entrance, with enough space to spread waste out on a sheet and sort it into a number of containers.

### Health and safety

Sorting waste can be hazardous and it is very important to protect the members of the sorting team.

- Choose a safe area, near to the site where you will finally be disposing of the waste but away from any vehicles. It should be in the shade, with access to water for cleaning, access to drinking water, and away from animals.
- Train the team properly on sorting, lifting, carrying and cleaning (as outlined in the training plan in Figure 1-6), the correct use of tools, and to ensure everyone understands the source of the waste being sampled (for example, to avoid waste from a hospital).
- Provide personal protective equipment (PPE) to all staff. This is shown in Figure 1-4 and listed in Figure 1-5.
- Supply a First Aid kit and make sure the team includes a trained First Aider.
- Avoid walking through waste when you cannot see the floor.





*Remember you could find almost anything at a dumpsite. Watch out for hospital waste, particularly needles and blood-stained waste. Even household waste can contain hazardous items like needles or solvents.*



**Equipment and staffing**

Sorting waste is hard and dirty work and it is very important for the people involved to be trained properly (see Figure 1-6). As an example, 10 people can typically sort 5 x 100 kg samples a day; or 25 samples over a 5-day period. As sorters become more familiar with the different materials, they will take less time.

Below is the ideal equipment checklist for a team of 10 people auditing 5 samples per day.

Figure 1-4: Suitable PPE for a waste sorter.

Equipment	✓
Tables or worktops to sort on.	
A scale for weighing samples – generally up to 150 kg. Medical or bathroom scales can work well if you have a flat hard surface to use. If you only have sand or uneven ground to work on, either use a table or hang a set of scales from a tree.	
A heavy sheet to store the samples on.	
A sieve to separate the small pieces with a gauge of around 1 cm.	
5 shovels, 5 rakes, 2 hand brooms.	
Litter pickers (plastic or metal grabbers) to pick and sort the waste if needed.	
As many waste containers as you have categories of waste.	
2 wheelbarrows to collect waste from tractors and trailers.	
1 large First Aid kit including eye bath.	
Personal protective equipment for the people sorting the waste including: <ul style="list-style-type: none"> <li>• Overalls – if these are too hot, make sure the important areas are covered: forearms (with long gloves), lower legs (getting brushed), and stomach area (when sorting on tables).</li> <li>• Leather and/or latex gloves.</li> <li>• Rubber boots.</li> <li>• Disposable face masks – there are different types, we recommend standard FFP3.</li> <li>• Portable wash-water facilities with soap and disinfectant.</li> </ul>	
Washing water and soap.	
Drinking water and lunch for staff each day plus regular rest breaks in the shade between each sample analysis.	

Figure 1-5: Ideal equipment list for a team of 10 people sorting 5 samples of waste a day.

Training session

Session title	Details	Resources
<b>What is the aim of the waste audit?</b>	<i>Introduce the aim of the waste audit.</i> Explain to the group that we want to understand what materials are in the waste, so that we can recycle more (and send less to the dumpsite).	None
<b>Sorting procedure</b>	<p><i>Show the team how to collect and sort the waste.</i> Steps are as follows:</p> <ul style="list-style-type: none"> <li>• Number each container and stick examples or pictures of each type of material on the front.</li> <li>• Deposit a 100 kg sample of waste on a plastic sheet using wheelbarrows and shovels. Spread the waste using shovels and remove any hazardous elements.</li> <li>• Separate the waste into the different materials, and sort it into the labelled containers. Where possible use pickers and shovels rather than hands.</li> <li>• When a container is full, either use a second container, or weigh and record, then tip the contents out and use the container again.</li> <li>• When complete, weigh each container on the scales with the waste inside it and record the weight.</li> <li>• Tip the waste out and record the weight of the empty container.</li> </ul>	<p>Equipment required to demonstrate the sorting process:</p> <ul style="list-style-type: none"> <li>• Shovels to mix and level waste</li> <li>• Waste picking equipment</li> <li>• Labelled containers (including sticky tape for attaching the label or sample to the container)</li> <li>• Tarps / plastic sheet spread out on the ground</li> <li>• Scales</li> <li>• Recording sheet</li> <li>• Pens</li> </ul>
<b>Health and safety and the use of personal protective equipment (PPE)</b>	<p><i>Ensure any risks to the welfare of the team are minimised.</i> Sessions include:</p> <ul style="list-style-type: none"> <li>• Dangers posed by waste, including from infection, needle sticks, glass, metal splinters, nails, razor blades, hypodermic needles and so on.</li> <li>• Supervisory staff to ensure that sorting staff adhere to health and safety measures.</li> <li>• Importance of avoiding dehydration and of taking adequate breaks.</li> <li>• Infection risks and importance of use of soap and water before eating, drinking and smoking.</li> <li>• Importance of good lifting techniques.</li> <li>• Importance of correct use of PPE and reasons for all.</li> <li>• Use of First Aid kit and eyebath in case of injury.</li> </ul>	<ul style="list-style-type: none"> <li>• Full PPE</li> </ul>

Figure 1-6: Template training session to prepare the waste sorting team before starting on a waste audit.

**A step-by-step guide to auditing waste**

1. Select a suitable area as described above. Spread heavy sheets on the ground to stop the waste samples mixing with the underlying soil.
2. Set up tables for sorting the waste; label the waste storage containers with the categories selected for sampling and arrange them around the edge of the tables. Keep some containers available for weighing unsorted waste, and have some additional 'overflow' containers for sorted waste in case they are needed.
3. Place the scale near the storage containers (a sturdy tree can be useful for this if it is a hanging scale). Record the empty weight of each container (ideally, they will weigh the same), and re-check them periodically.

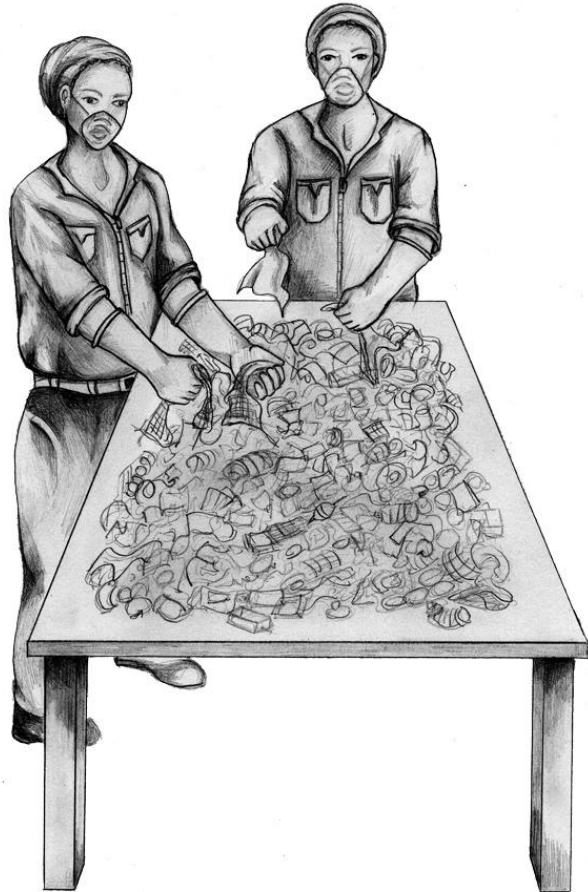

Figure 1-7: Using a table makes the sorting process quicker and more comfortable.

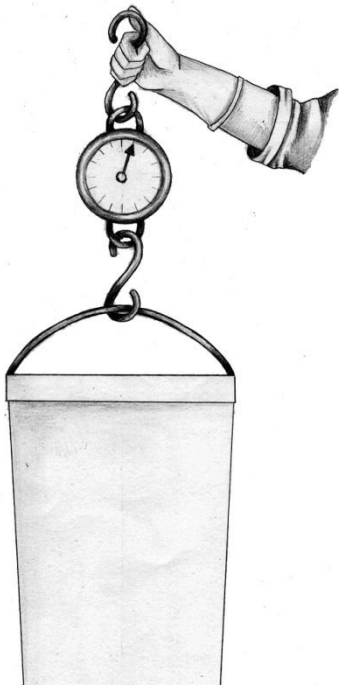

Figure 1-8: Use hanging scales to weigh samples.

4. Consider how you will take samples of waste, to make sure they are representative. If your study is about office waste then try to sample from several offices; if you are interested in household waste, try to collect samples from both wealthy and poor areas. Take care that the waste is not dangerous, for example from a hospital, unless you are prepared for this. Beware of building waste as it may contain asbestos which can be fatal if inhaled.

5. Collect the following information on each sample:

- Date
- Time
- Vehicle details, such as handcart or truck
- Origin of waste, such as offices in commercial district
- Weather conditions.

6. Sample the agreed amount of waste (either 50 or 100 kg) and place it on the tarpaulin or plastic sheet. To weigh the sample, place waste into empty containers and weigh the required amount. If this is difficult, one method is to stand on the scales, set it to zero, then hold a sack or container and record how much the weight increases. Remember you will need to subtract the weight of the empty containers.



Figure 1-9: Hang the scales from a tree to weigh the full containers.

7. Begin sorting the waste sample without delay.

Empty all bags, packets, and other containers of their contents and separate the different materials (such as metal lids from glass jars). Where something is made using more than one material and is difficult to separate (such as paper and plastic stuck together), place with whichever is the dominant material.

8. Place each separate item in the correct storage container. If there is any confusion, supervisors can advise sorters of the correct container.

9. Sort all the waste until the largest item you have left is around 1 cm. The pieces that are smaller than 1 cm are called *fines*. These will take a long time to sort, so it helps to work with a smaller, representative amount, and then multiply the results back up to give an estimate of the total. To produce a small representative sample size, follow the steps below and in Figure 1-10.

- a. Record the weight of the total 'fines' category (for example, 5 kg).
- b. Pour all the fines into a cone shape on the floor.
- c. Flatten it out using a shovel.
- d. Divide into four and discard two opposing quarters.
- e. Combine the remaining two quarters.
- f. Repeat until the sample size is small enough to sort in a short space of time. Record the weight of this final sample (for example, 500 g).
- g. Sort the final sample into categories and record the weight of each material.
- h. Multiply the weight of each category of fines back up to account for the original sample size (in this example, multiply each category of fines by 10 to account for the 5 kg of fines in the total sample).

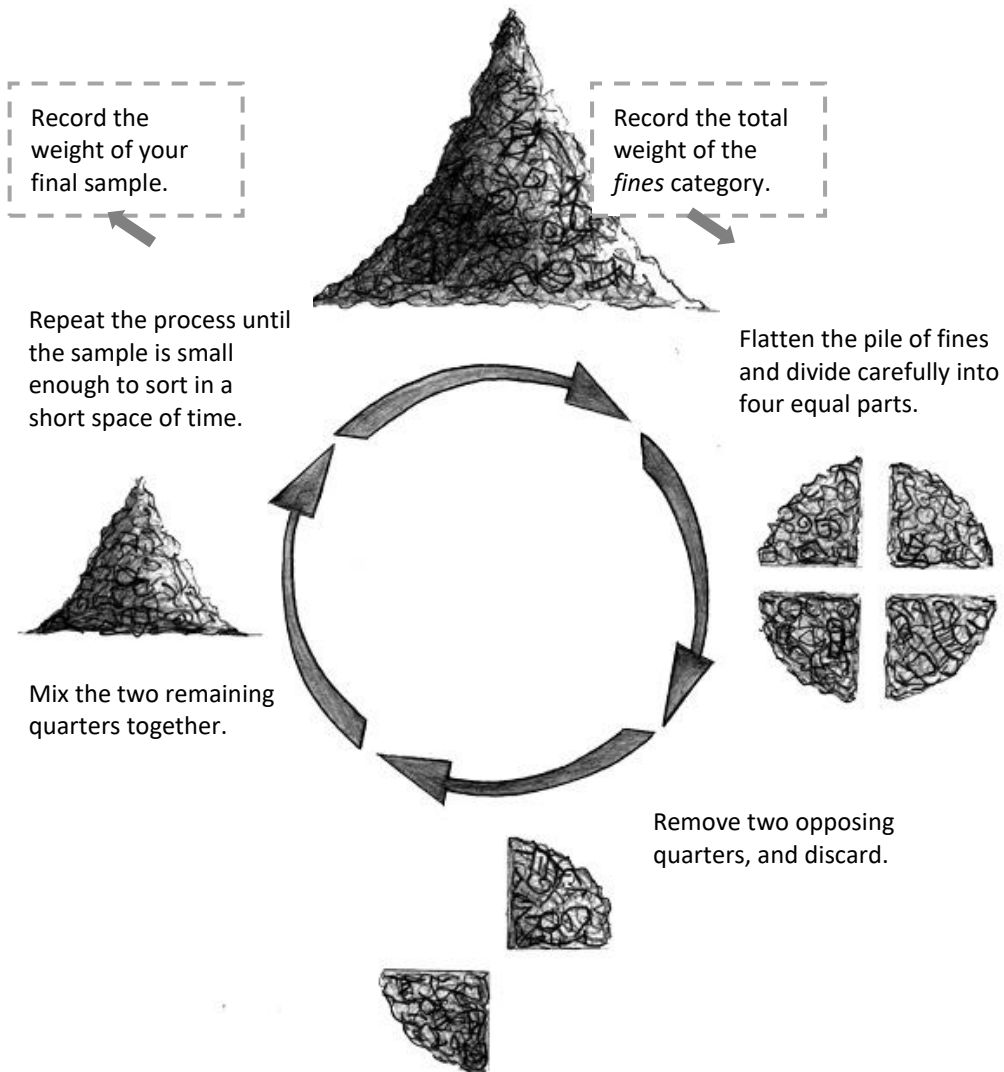

Figure 1-10: How to produce a small and representative sample of fines.

10. Weigh and record the total weights of each storage container, including any larger waste items sorted but not stored in the containers. Remember to subtract the weight of the empty container from your results.
11. Remove the sorted waste by wheelbarrow and if suitable offer it to informal recyclers for recovery. Make sure you dispose of everything else in a way that is least harmful to the environment as possible.

### Analysing and presenting your results

Record the final weight of each category in a table (include the weight of the fines, but not of the containers). When you have completed all your samples (in this example, 25 samples of 100 kg each) add the weights and calculate the percentage of each material group in the waste. Do not worry about decimal places, just round up or down to the nearest whole number. Calculate the percentage of each material in the total sample (for organics in this example, the sum would be 911/2500, and the multiplied by 100).

<i>Main material groups</i>	<i>kg</i>	<i>%</i>
<i>Organics</i>	<i>911</i>	<i>37</i>
<i>Other</i>	<i>482</i>	<i>19</i>
<i>Plastics</i>	<i>381</i>	<i>15</i>
<i>Textiles</i>	<i>195</i>	<i>8</i>
<i>Paper and paperboard</i>	<i>145</i>	<i>6</i>
<i>Construction and demolition</i>	<i>139</i>	<i>6</i>
<i>Hazardous waste</i>	<i>131</i>	<i>5</i>
<i>Glass</i>	<i>34</i>	<i>1</i>
<i>Metals</i>	<i>83</i>	<i>3</i>
<b>TOTAL</b>	<b>2500</b>	<b>100</b>

Figure 1-11: Example weights and percentages of a 2.5 tonne waste analysis (25 samples of 100 kg).

Here is the same data converted into a pie chart:

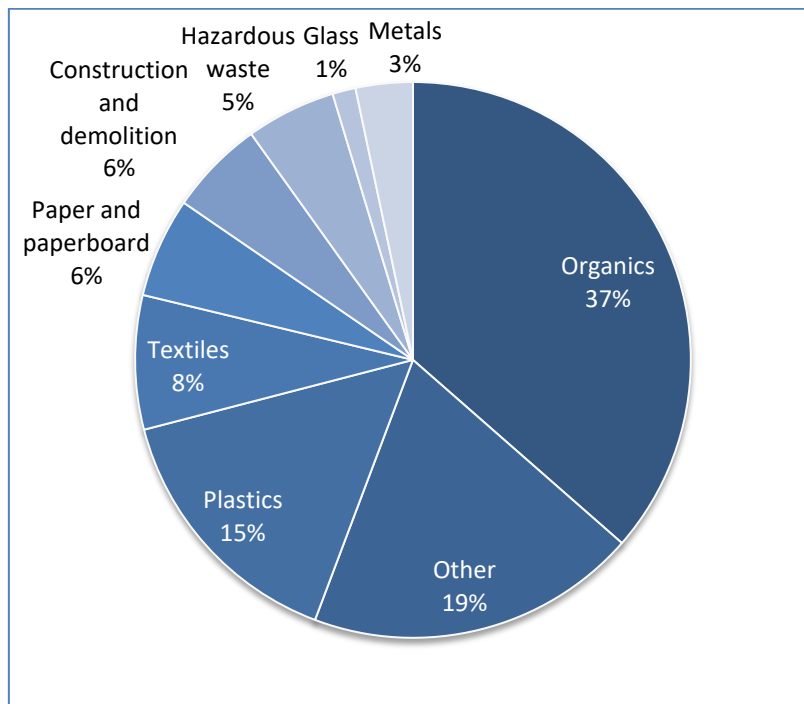

Figure 1-12: A pie chart showing example waste audit results.

### Breakdown of results

Think about what you need to know – sometimes it is useful to break the information down into further sub-groups.

In the example above, plastics only made up 15% of the *weight*. However, plastic is not very heavy so even though it does not weigh very much, there might still be a large *volume* or quantity.

To find out which types of plastic make up the overall category ‘plastics’, see How-to guide 7.1 *Identifying common types of plastic*. Within this example, LDPE film (a group including plastic bags, water pouches and other similar plastics) made up 57% of the total weight of plastics. The other significant group was woven PP, generally rice sacks and other similar containers, at 14%.

<i>Plastics</i>	<i>kg</i>	<i>%</i>
<i>LDPE film</i>	<i>217</i>	<i>57</i>
<i>Other plastics</i>	<i>80</i>	<i>21</i>
<i>Woven PP</i>	<i>53</i>	<i>14</i>
<i>Fines - plastics</i>	<i>15</i>	<i>4</i>
<i>Green PET</i>	<i>11</i>	<i>3</i>
<i>HDPE</i>	<i>4</i>	<i>1</i>
<i>Clear PET</i>	<i>0</i>	<i>0</i>
<i>Total</i>	<i>381</i>	<i>100</i>

Figure 1-13: Different types of plastic separated into more specific categories.

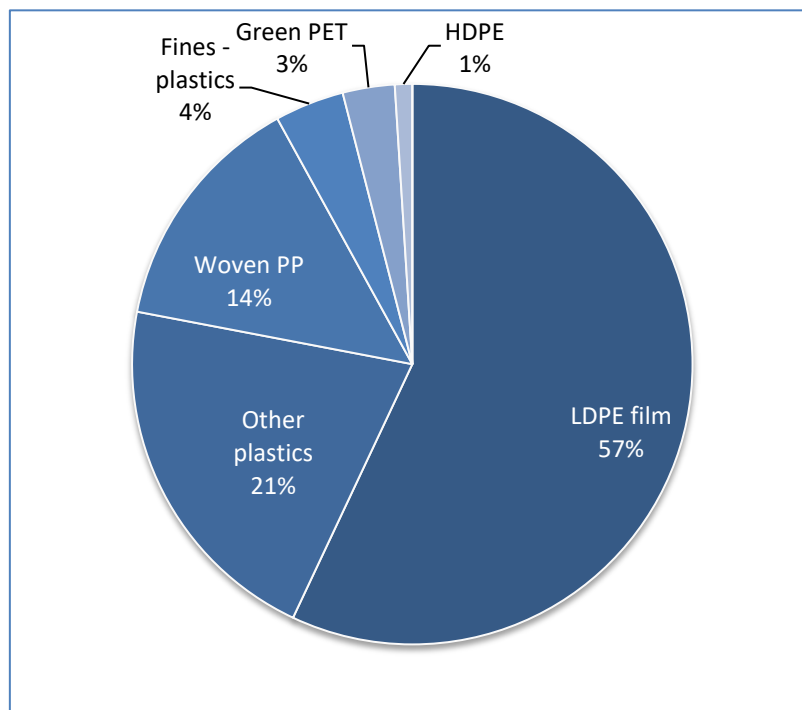

Figure 1-14: A pie chart showing the different types of plastic in the waste sample.

You can do the same with all of the waste groups you want to consider, for instance organics, textiles, hazardous waste, construction waste, glass, metals and ‘other’.

### What do the results mean?

The results tell you what is in your waste, so you can decide which materials will be available and suitable to work with.

Consider waste reduction and recycling projects that:

- **Reduce the quantity** of materials ending up the waste dump, to reduce the significant environmental impact of waste disposal.
- **Maximise the value** of reprocessed material, so you can develop a sustainable business model for your recycling enterprise. The technique should be fairly simple and low cost. This will ensure it is accessible to the local community, maintained into the future, and possibly replicated in other communities.



*When you decide on a material to work with, try to find out where it is from and ask if it can be kept separate for you to collect.*



## 2. How to transform woody waste to fuel briquettes

*Instead of chopping down trees for firewood, you can make a fuel for cooking by using woody waste materials.*

**Summary:** Carbonise the material in a barrel with limited air (like making charcoal), then grind it into a powder and mix with binder. Compress the mixture in a briquette mould and then dry the briquettes in the sun to make a cheap and effective alternative to wood or charcoal fuel for cooking.

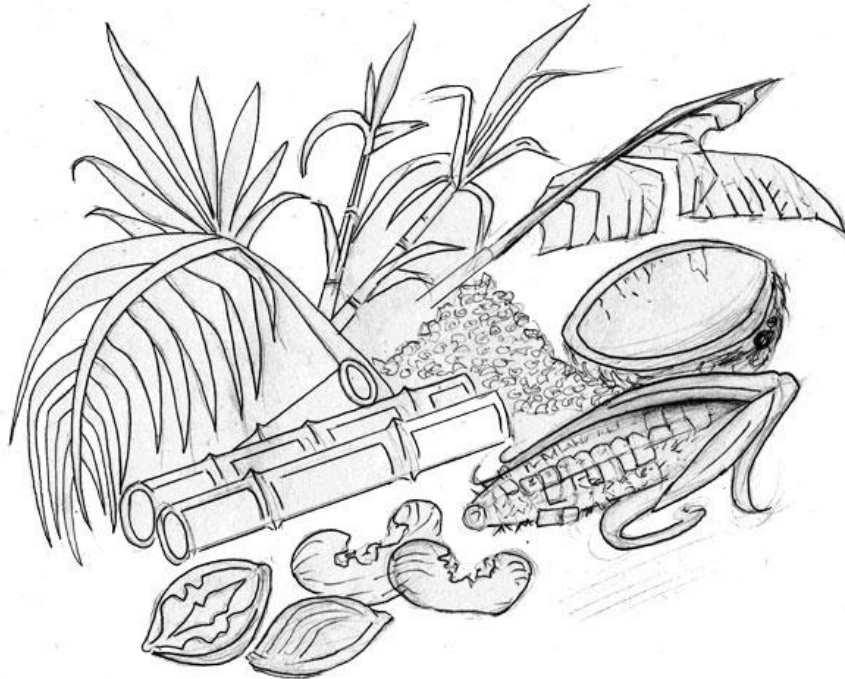

**Waste materials:** Dried leaves, twigs, straw, coconut shells, baobab shells, maize cobs, groundnut shells and sawdust. Do not use anything that is too wet or anything other than dry leaves or woody waste (make sure there are absolutely no plastics in the waste).

**Product:** Charcoal briquettes.

**Benefits:** Briquettes are cheaper than traditional charcoal. When used as a fuel for cooking they are less smoky than wood, reducing the problem of indoor pollution. They burn hotter and for longer than traditional charcoal. They do not require the cutting of trees. The equipment is cheap and the process is easy.

### Hints:

- To make charcoal briquettes you need to **carbonise** the material. This needs some air but not too much or you will make ash, not charcoal.
- Try out different mixtures of materials that you can find locally – **experiment** with what you can find easily. One example of a mixture that works is 50kg of groundnut or coconut shells plus 25kg mango leaves. You will then need 1kg cassava flour (or another similar starch) and

2 litres of water to create a binder for the briquettes. If you are using leaves, you may want to try adding some woodier material (like coconut shells) to help bind them. It is better to have a consistent mix of materials so the briquettes burn at a steady rate.

- If you are only using sawdust you do not need to carbonise it – just mix the sawdust with the binder and compress into briquettes. The sawdust briquettes cook fast like firewood; the charcoal briquettes cook more slowly.
- 20 charcoal briquettes is enough fuel to cook a meal for 5 people on 2 pots. The briquettes can be sold for a lower price than the equivalent fuel in firewood, and they are also less smoky.



*You will be working with fire and combustion, so make sure you have water nearby to put out any flames.*

*You will be using heat and fire. Make sure you have fireproof gloves (fabric, NOT rubber), heatproof boots (NOT rubber), and cover your arms and legs with overalls or heavy trousers.*

*Be aware that the process produces a lot of smoke. Never stand over the smoking barrel, and think about anyone nearby that the smoke may affect.*

*Stand back when opening the barrel after carbonising, as flames may leap out. Have somebody ready with water to pour on the flames and sprinkle on the material so it does not burn in the open air.*

#### **You will need:**

- Overalls, gloves, masks, covered shoes or boots
- Dry woody material (it is best to try a range of different materials and combinations of materials, including twigs, leaves and shells)
- 1 metal barrel – an oil drum with several air holes in the underside, handles on two sides and a large hole in the top with a lid or chimney
- Stick or rod to turn the material
- Metal wheelbarrow or heatproof container to hold carbonised material after burning
- Water to sprinkle on the carbonised material
- Mortar and pestle or another way to crush the charcoal
- Gum or starch from cassava or similar as a binder (you can even use clay)
- Cooking stove, fuel and a container to warm and mix your binder with water
- A place to mix your material with the binder (a table or a plastic sheet on the floor)
- Briquette press (see below)
- A place to dry the briquettes – in the sun if it is dry, out of the rain if it is wet.

**How to prepare the carbonising barrel**

Starting with a standard oil barrel, chisel a large hole in the top (a). The hole needs to be large enough to comfortably fill the barrel with woody waste material.

Then cut some holes in the underside of the barrel, around 6cm across (b). These holes will be used to poke material through and start the fire. You will also need a stick or rod long enough to reach to the bottom of the barrel comfortably.

It is also good practice to attach some handles to the sides of the barrel, and make a chimney that fits over the top (c).

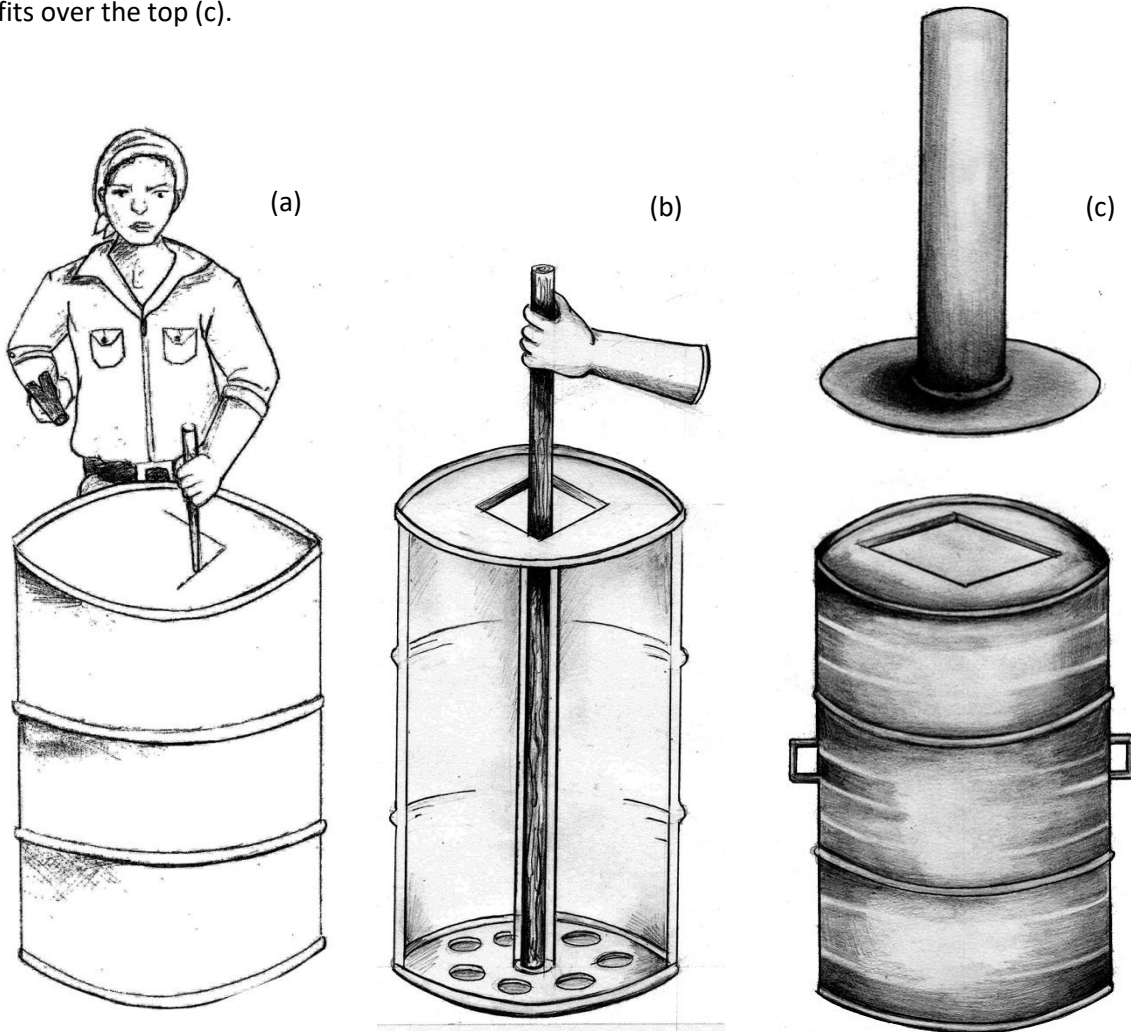

Figure 2-1: Prepare the barrel by cutting a large hole in the top, a series of small holes in the bottom, and adding handles and chimney. You will need a stick long enough to reach the bottom of the barrel to stir the contents.

**How to make a briquette press**

There are lots of ways you can make a briquette press and each will make different shape briquettes. This example produces square briquettes.

Drill a hole in the centre of the wooden block, large enough for rebar to fit in it (a).

Make the briquette mould by welding four plates together to make a square tube, and then welding two narrow plates onto an open end, with a channel down the centre wide enough for the rebar to fit through (b).

Weld one piece of rebar onto a plate to make the base (c).

Weld one piece of rebar onto a plate to make a plunger (d).

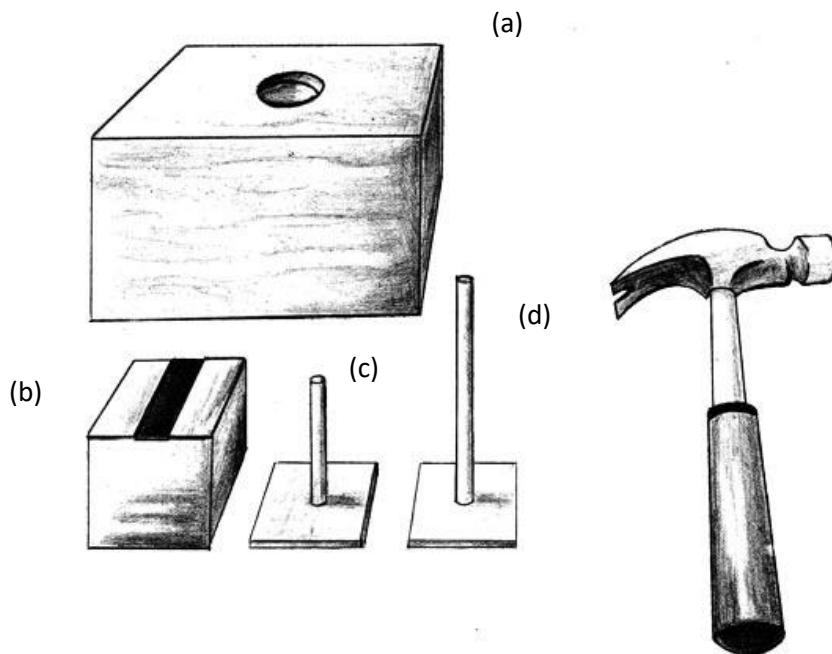

Figure 2-2: Components of a briquette press, *design concept by Amy Smith, MIT.*



If you don't have a briquette press and cannot make one, you can make briquettes from sawdust and binder by hand, simply squeezing them into balls and leaving them to dry in the sun.

Figure 2-3: Sawdust briquettes can be made by hand, *concept by Joyce Lockard.*

### 1. Sort

Choose material that is brown and dry – try different things that you find nearby. **Remove all materials that you do not want in your briquettes.**



*Make sure there are no plastics in your mix.*

*Never burn plastic.*



Figure 2-4: Collect suitable dry, woody waste materials.

### 2. Light

*If you are using sawdust you can skip straight to Step 6: Mix.*

Put the material in the barrel and poke dry leaves through the holes in the base. Sit the barrel on three stones (old block is fine). Use the stick to make sure the material is distributed evenly throughout the barrel. Light a fire underneath.

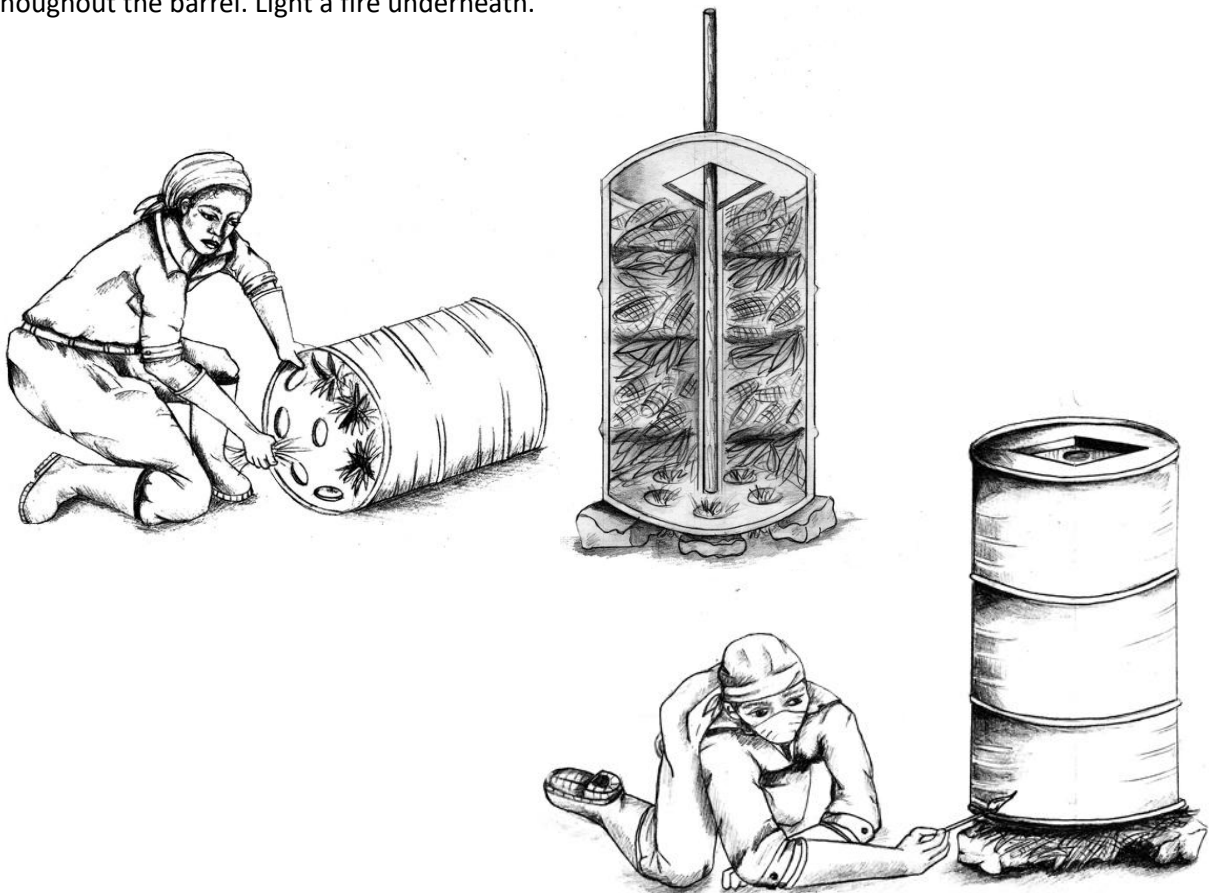

Figure 2-5: Fill the barrel with woody waste material, place on top of stones and light from underneath.

### 3. Carbonise

It will produce plenty of smoke. Using the stick, turn the material to make sure it is all carbonised. When the smoke reduces and flames come, wait a few minutes then put the lid on the barrel. Remove the stones underneath and seal any air gaps around the bottom of the drum and the lid with sand or dirt.

Leave for 5 to 10 minutes then check. The material inside should be like small pieces of charcoal (char). If it is not yet carbonised, then leave for longer. Do not leave it for too long or it will turn to ash. Different materials take different amounts of time depending on their water content. For example, coconut shells take 5 to 10 minutes to carbonise. You will need to practise a few times to get it right!

Always be careful when you open the lid. Occasionally there will be flames leaping out, so you should keep your head and arms clear.

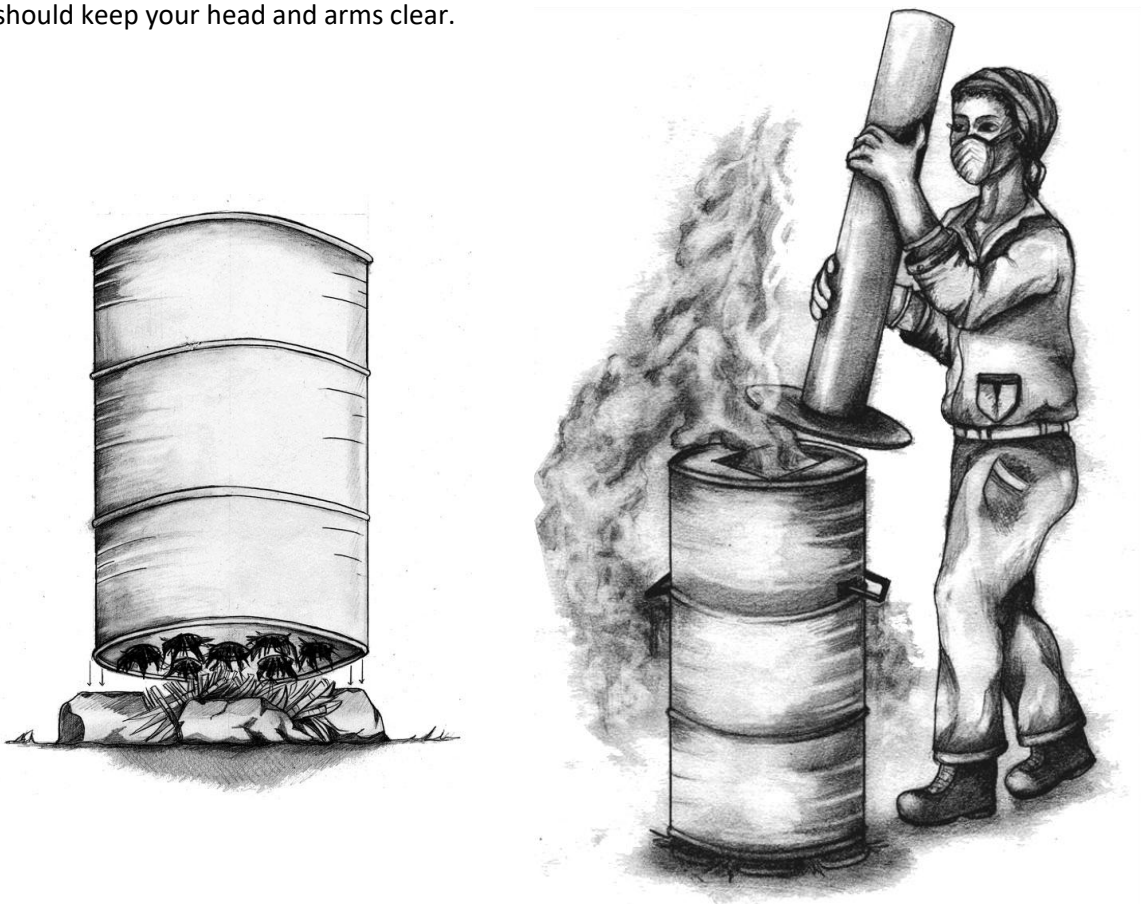

Figure 2-6: Allow the material to carbonise but do not let it burn completely. A chimney is useful to direct the smoke away.



**Always be careful when you open the lid, even if there is no flame.** When the oxygen in the air comes into contact with the hot gases it can cause a small explosion. Keep your head an arm's length away from the barrel. Always have water ready in case you need it.

#### 4. Tip

With a person on each side, pick up the barrel and tip the charred contents into a metal wheelbarrow or heatproof container. Sprinkle it with water to stop it burning in the open air.



Figure 2-7: Tip the contents of the barrel into a wheelbarrow and sprinkle with water to stop it burning.

#### 5. Cool and crush

When the carbonised material has cooled, crush it to powder. You can use a mortar and pestle, or crush it in your hands, or put inside a sack and hit with a stick.

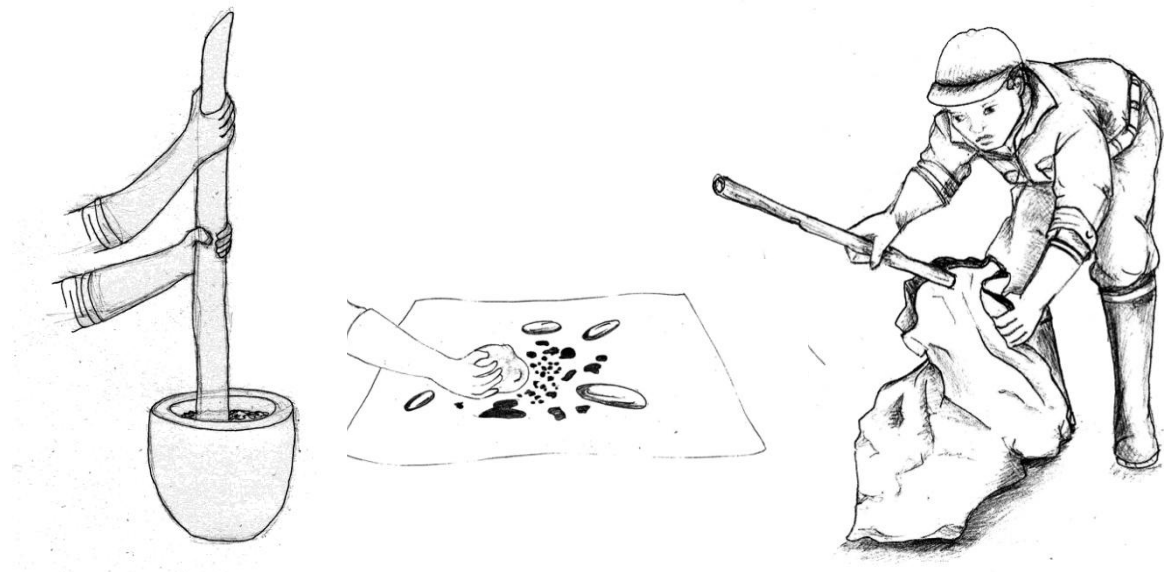

Figure 2-8: Crush the carbonised material into a coarse powder.

## 6. Making and mixing your binder

To bind the carbonised powder into a briquette, you will need to mix it with a binding agent. The best binder is starch and the approach is similar for all types of plant starch – just boil a plant or material containing starch in a small amount of water until a thick sticky paste forms, like porridge. Different types of starch include:

- Cassava starch: this is cheap and effective and can be found widely in West Africa
- Corn or maize starch or maize flour: this is more widely used in East and Southern Africa
- Wheat starch or wheat flour, potato starch or rice flour
- Other alternatives include gum Arabic or acacia gum which is harvested from acacia trees. This is very common in semi-arid areas especially in Africa Sahel and in particular Senegal, Sudan and Somalia. You can even use newspaper or mud from termite mounds mixed with water to create a binder paste.



Figure 2-9: Prepare your binder by mixing it with water and heating it until it turns into a sticky paste.

Use enough binder to hold the mixture together, but not too much that your briquettes fall apart.



Figure 2-10: Make a mound of powdered char, scoop out a hollow and mix in the binder (like making bread).



## 7. Mould



See “How to use a briquette press” on next page. Sit the metal base inside the mould and rest the stick of the base inside the hole in the wooden block. Push the material inside the briquette press with your fingers. Put the plunger on top with the stick pointing up and hit with a hammer 5 times, taking care of your fingers.

Twist and remove the plunger. You will be able to see the briquette material, compressed in the bottom of the mould.

Lift the mould out of the wooden block and rest on top. Push the mould down and the briquette will remain on top of the base. Twist to remove and put in a dry place, in the sun if it is not likely to rain.

Figure 2-11: Using a briquette press.

Depending on the climate, charcoal briquettes take 1.5 - 7 days to dry, sawdust 2-8 days. Turn them for even drying.

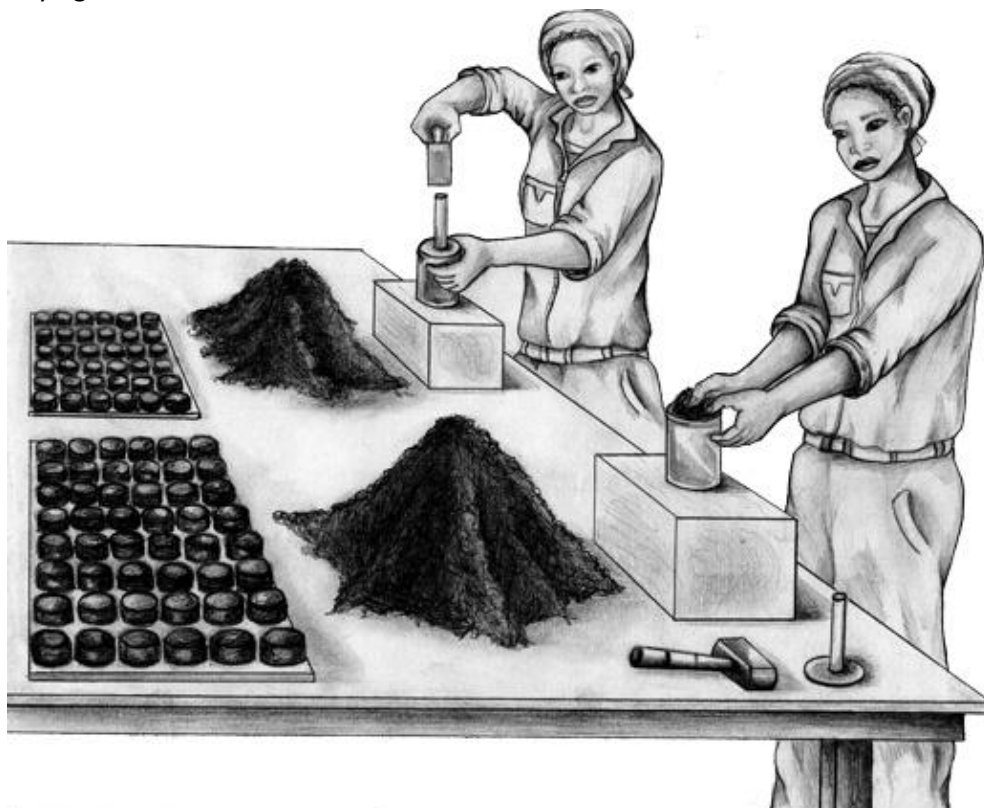
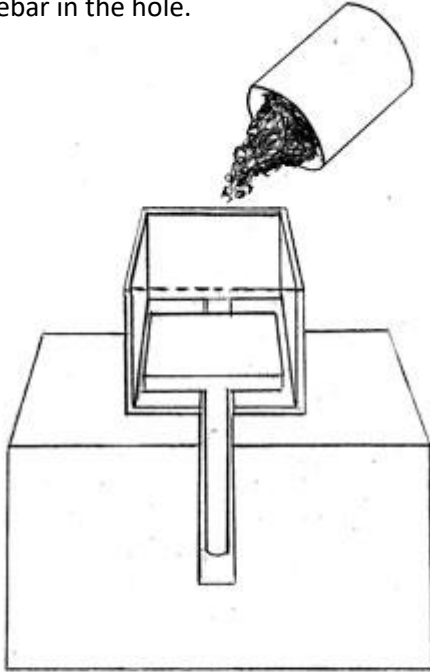

Figure 2-12: Working as a team, you can produce hundreds of briquettes in a day.

### 8. How to use a briquette press

1. Put the base into the mould and sit on the wooden block with the rebar in the hole.



2. Fill the mould with the char and put the plunger over the top.

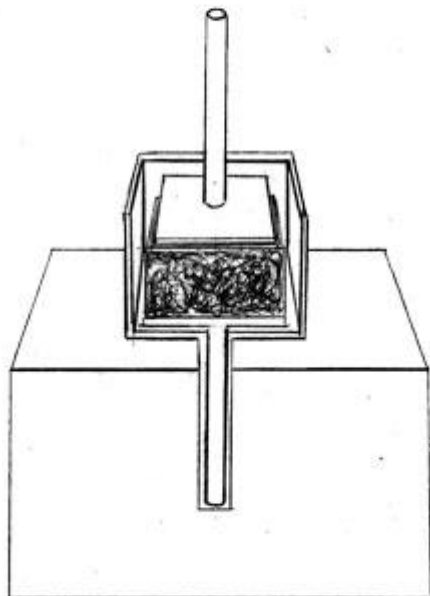
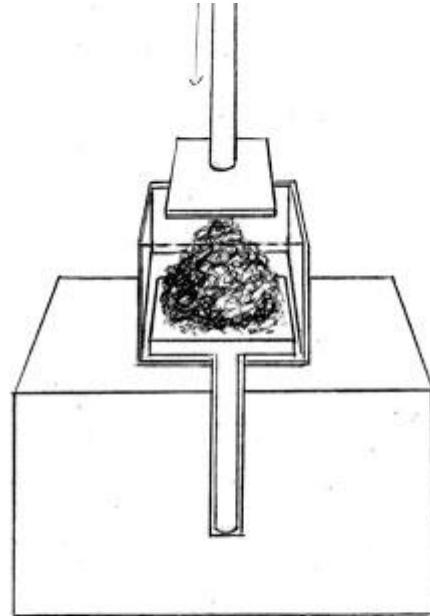

3. Hammer the top of the plunger to squeeze out the water and compress the char into a briquette shape.

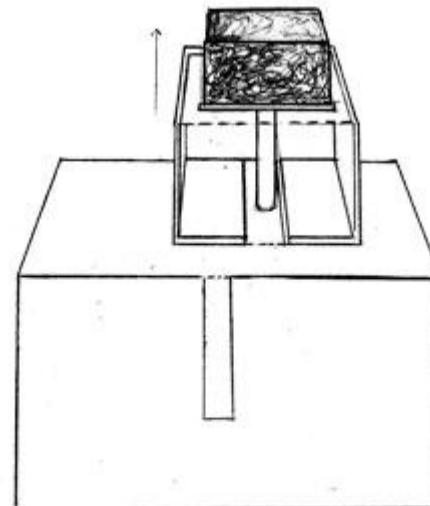

4. Lift the briquette mould out and sit the rebar on the wooden block. Push the mould down and the briquette will pop out. Twist and remove.

Figure 2-13: How to use a briquette press.

## 9. Market

You can sell the charcoal briquettes in small daily portions, or in bigger sacks.

Make some and give them to people for free so they understand that they burn hotter and for longer than normal charcoal!

EXAMPLE: In The Gambia, 20 briquettes are used to cook a meal for 5 people (using 2 pots). This costs 20 dalasi (around US\$0.45) and replaces the equivalent in firewood of 35 Dalasi (US\$0.75).

Chapter 9 of *Making Waste Work: A Toolkit*, provides a detailed business case for making charcoal briquettes.

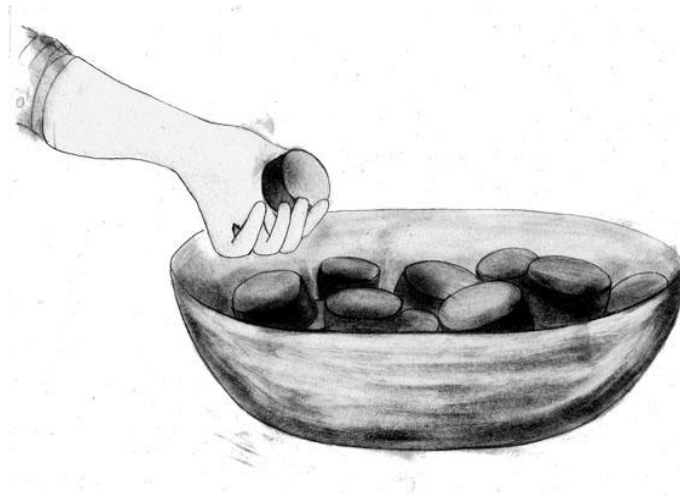

Figure 2-14: Explain the benefits of the charcoal briquettes to potential customers.

**Hint:** If you sell the briquettes in paper bags, you can tell people to use the paper to start their fire.  
**Never burn plastic!**

Selling points of charcoal briquettes:

- Low smoke, healthier to use
- Cheaper than firewood and normal charcoal
- Do not require the cutting of trees
- Helps protect the forest
- Helps keep the community cleaner.

**Acknowledgement:** *Process courtesy of Women's Initiative The Gambia.*

Choosing a fuel

You can use many different materials to make charcoal briquettes. This chart shows how much energy (heat) is released by different materials, with traditional fossil fuels on the left and fuels from waste on the right.

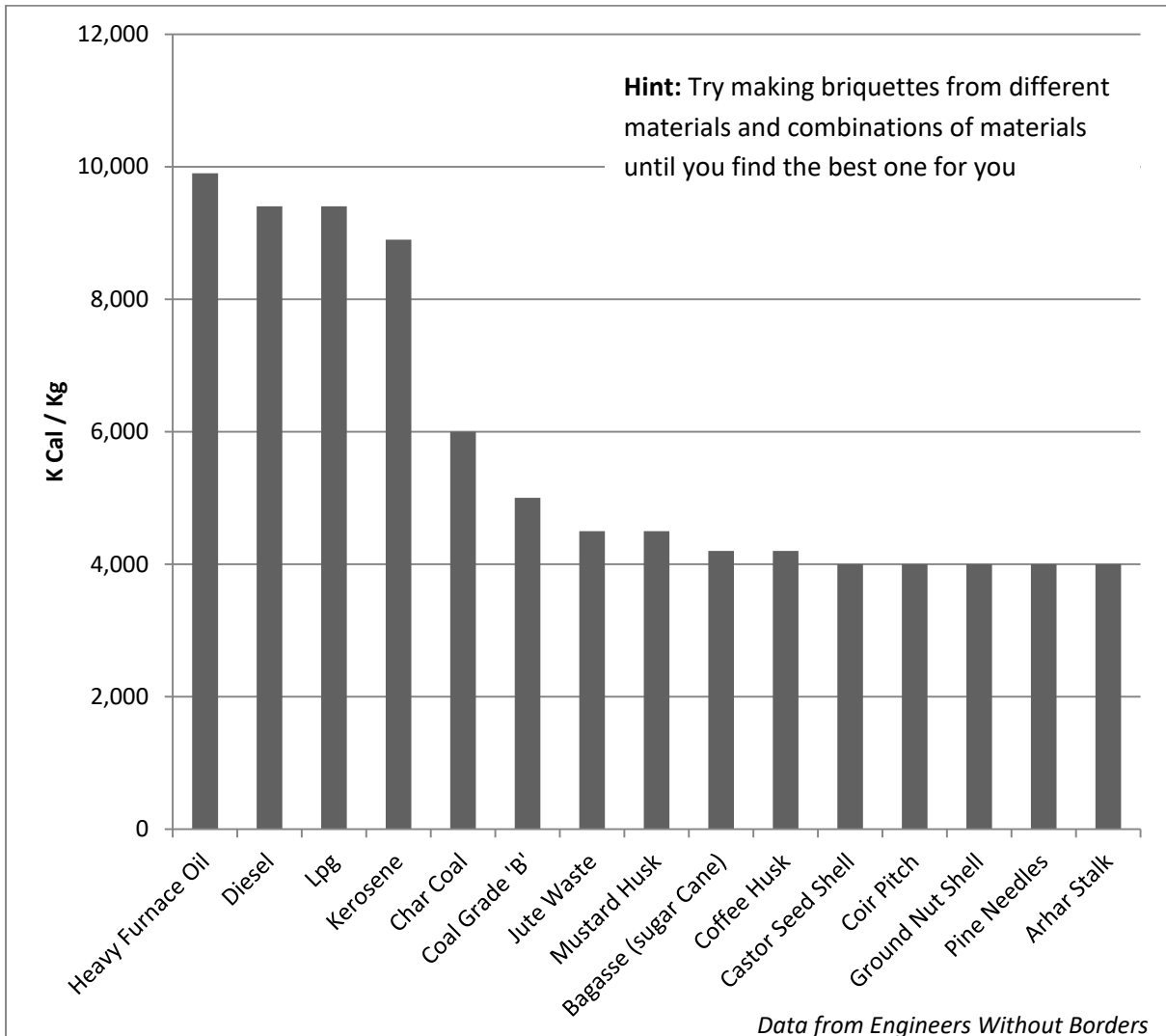

Figure 2-15: Different woody wastes produce different amounts of energy (heat).

### 3. How to convert organic waste into biogas

*You can make a free cooking gas by digesting wet organic waste in a sealed chamber.*

**Summary:** Place wet organic waste, such as food waste, in a sealed chamber with no air inside. As it digests, the waste will release a gas which can be captured and used for cooking. The system needs to be airtight and the temperature close to 35°C.

**Waste materials:** Plant waste that is starchy, sugary or fibrous; fatty substances including animal fat or oil cake from oil seeds; flour swept from the floor of a flour mill; leftover and stale food; damaged or over-ripe fruits; insect damaged grain; non-edible rhizomes of banana or cane; tea leaves; animal dung, abattoir waste, and human excreta. If necessary the feedstock must be pulped or ground and mixed with water so it is like a soup.



***There are lots of different designs of biodigesters. If you are planning to build one, it is best to read this entire chapter before starting, so you can better understand the technology and the important points to consider.***

**Product:** After 14-21 days, the process will produce biogas and a nutrient-rich soil conditioner called digestate. About 1-1.5kg starchy material typically yields enough gas to cook the meals of 4-5 people. If the digester is working properly, the digestate will have little smell.

**Benefits:** Making biogas from organic material is a good way to manage potentially harmful organic wastes. Cooking with biogas does not produce smoke so it is ideal for the home, and it reduces the need to cut down trees for firewood. The digested slurry can be used wet or dry as a valuable soil conditioner, reducing the need for chemical fertilisers<sup>3</sup>. The benefits of using compost and soil conditioner are discussed in *How to convert organic waste into compost*, How-to guide 5.



*Biogas is highly flammable. Make sure you have no naked flames or sparks near your biodigester.*

*Biogas can suffocate you in an enclosed space. Always make sure you work in a well-ventilated area and with at least one other person.*

*Animal dung contains bacteria, viruses and, possibly, parasites. When handling such material, use gloves and overalls and wash your hands afterwards.*

A biogas plant needs some methane-producing bacteria to get it started. This is found in animal dung, so a small amount is used to start the process even if it is not the main feedstock. Once the system is producing biogas the bacteria reproduce and keep the process going.

<sup>3</sup> Do not use the slurry directly on plants. Add it to a compost heap first so that the heat can kill any disease-carrying bacteria.

## Biogas essentials

The process is the same as what happens in a cow's stomach, where bacteria in the stomach convert food into a semi-solid material (dung) and biogas (a mix of methane and carbon dioxide).

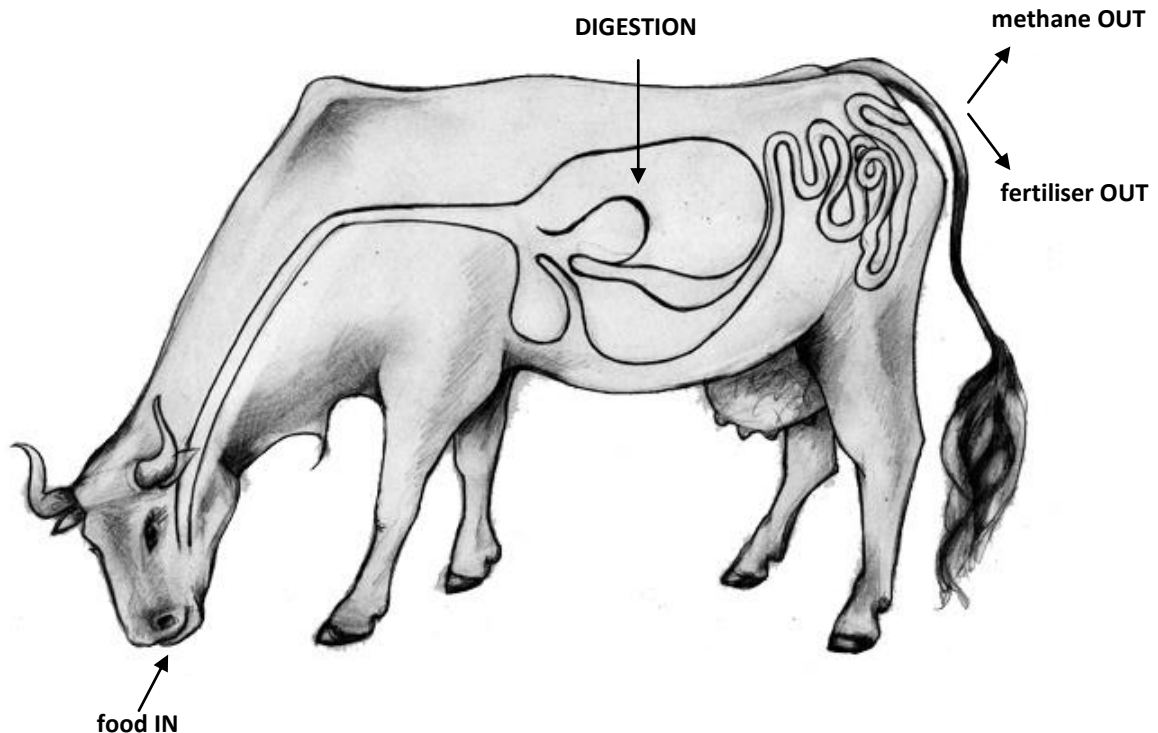

Figure 3-1: A biodigester works in a similar way to a cow's digestive process, producing methane gas and a semi-solid fertiliser.

It is possible to build family-size, community-size, and even very large industrial-scale biodigesters which serve entire cities.

Whatever the size and design, all biogas plants need:

- A large container to hold the mixture of decomposing organic matter and water (digester)
- A container to collect the biogas (gas holder)
- A way to add more organic matter (inlet)
- A way to move the gas to where it will be used (gas outlet)
- A way to remove the residue (slurry outlet)
- A way to insulate the container and keep it warm, unless the container is already in a tropical country with a temperature around 35°C.



***Larger underground masonry biogas plants can be more reliable than the cheaper, smaller-scale versions described in this toolkit, although specialist training is required. There are now about 45 million masonry biogas plants in China, 5 million in India, almost 400,000 in Nepal and another 400,000 in the rest of Asia (Bangladesh, Cambodia and Vietnam).***

**Typical biodigester designs**

The most common type of masonry biogas plant is a **Fixed Dome Biodigester**.

The design combines the slurry container and biogas container in single chamber. As the slurry breaks down, it releases the gas, which rises to the top of the dome and can be piped away to a kitchen stove.

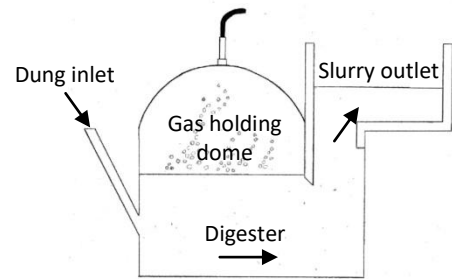

Figure 3-2: A fixed dome biodigester.

The other common type is a **Floating Dome Biodigester**, in which the gas container floats in the slurry. The gas container rises as the biogas is produced, and sinks again as the biogas is used.

The two designs described in this toolkit are based on the Floating Dome Biodigester. They have been selected because they are relatively low capital and are simple, popular designs if used on a small scale.

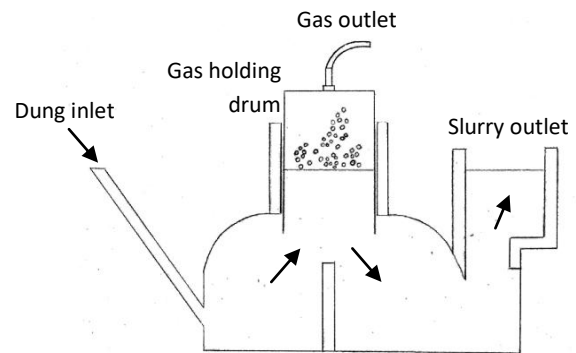

Figure 3-3: A floating dome biodigester.

The **Tubular Bag Biodigester** sits in a trench in the ground. Biogas collects in the top of the flexible plastic tube and is piped away. See *How to build a tubular plastic biodigester*, How-to guide 3.1, for detailed instructions.

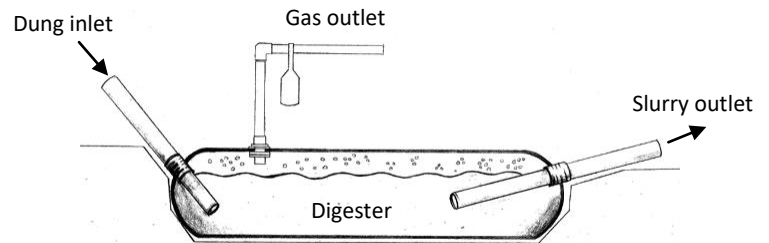

Figure 3-4: A tubular bag biodigester.

The **ARTI Floating Dome Biodigester** is made with a smaller container sitting upside down inside a larger container. The smaller container rises as it fills with biogas. See *How to build a floating dome biodigester*, How-to guide 3.2, for detailed instructions.

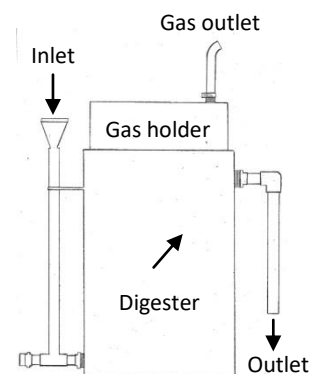

Figure 3-5: An ARTI floating dome biodigester.

## Working with Biogas: Safety First!



### ***Risk of fire and explosion***

*Methane, which makes up to 80% of biogas, can be explosive! This makes it a good cooking fuel but it also means you need to take extra care.*

*Do not use naked flames or anything that might spark (including power tools, normal electrical switches and static electricity) near the digester.*



### ***Asphyxiation***

*Biogas consists mainly of methane (CH<sub>4</sub>) and carbon dioxide (CO<sub>2</sub>), with low levels of hydrogen sulphide (H<sub>2</sub>S) and other gases. Each of these has its own problems, as well as displacing oxygen.*

- *CH<sub>4</sub> – lighter than air (will collect in roof spaces), explosive (see above).*
- *CO<sub>2</sub> – heavier than air (will collect in sumps), slightly elevated levels affect breathing, higher levels displace oxygen as well.*
- *H<sub>2</sub>S – smells like rotten eggs, can be harmful to the nose and lungs, becomes odourless as the level increases to dangerous and fatal.*

***High levels of hydrogen sulphide can kill.***



### ***Disease***

*Always wash thoroughly after working around the biodigester (and particularly before eating or drinking). Avoid contact with the contents of the digester.*

*Pathogens (disease carrying bacteria) are destroyed by heat, but there might still be pathogens in the digested slurry. Therefore it is advisable to re-use the effluent by mixing it with fresh feedstock and then pouring back into the digester. Alternatively add the slurry to a compost heap, where the heat will destroy any remaining pathogens.*



## Biodigester maintenance and troubleshooting

1. The biodigester needs maintenance and must be fed every day with organic waste and water. If you do not have enough feedstock to keep the biodigester working, consider collecting food waste or slurry from elsewhere.
2. Make sure you add enough water to the biodigester – the contents should be liquid, like a soup. However, if the soup is too thin, the solids and liquid will separate in the container and the digester will not work properly.
3. Do not use soapy water, pesticides or antibiotics in the mix. These will kill bacteria that generate methane gas.
4. Methane gas is produced when the pH level is 6 to 8.5 (alkaline). If the biodigester is over-fed it can become acidic, producing gas but no flame. If this happens, test the outlet slurry with litmus paper which is sold at most pharmacies. If your system is too acidic (with a pH level lower than 6), stop adding more feedstock, and then build up the feed rate slowly. Add more fresh animal dung to reseed the mix with the right kind of bacteria. This problem is more common with smaller systems (0.5 or 0.75 m<sup>3</sup>) than with larger systems.
5. Biogas is produced best at a temperature between 25 and 37°C. When the temperature is below 15°C almost no gas is made. You can keep your biogas unit at the right temperature by insulating it.
6. Biodigesters do not kill all disease-carrying pathogens, so do not use the effluent (output slurry) from the process directly on plants. Instead, recycle the liquid by using it to mix the feedstock for the biodigester, or put it on your compost heap. The heat generated by the compost heap will destroy the pathogens.
7. If you can smell gas, check for loose connections, damaged taps or holes. Repair with sticking plaster or tape.
8. If not enough gas is produced:
  - Check for a loose connection, a broken section of pipe or a fold in the pipe stopping the gas flow. Replace any damaged sections of the hose pipe. Gas leaks are the most common problems in a biodigester. Great care must be taken to stop gas leaks, with good quality sealing materials.
  - Clear the water from the gas pipe. Do this by opening the joins and pouring out the water, or making a hole in the pipe, draining out the water and then covering the hole with tape.
9. Some biodigester designs need a water trap as a safety valve to prevent unsafe build-up of large amounts of gas. It is simple and cheap to make (see *How to build a tubular plastic biodigester*, How-to guide 3.1). Keep the water level topped up in the water trap: it will evaporate so will need topping up periodically.

Once the basic principles of generating and using biogas are understood, it is possible to create your own designs according to the materials and budget you have available.

The example illustrated in Figure 3-6 uses an oil barrel as the digester and a rubber ring to collect the gas.

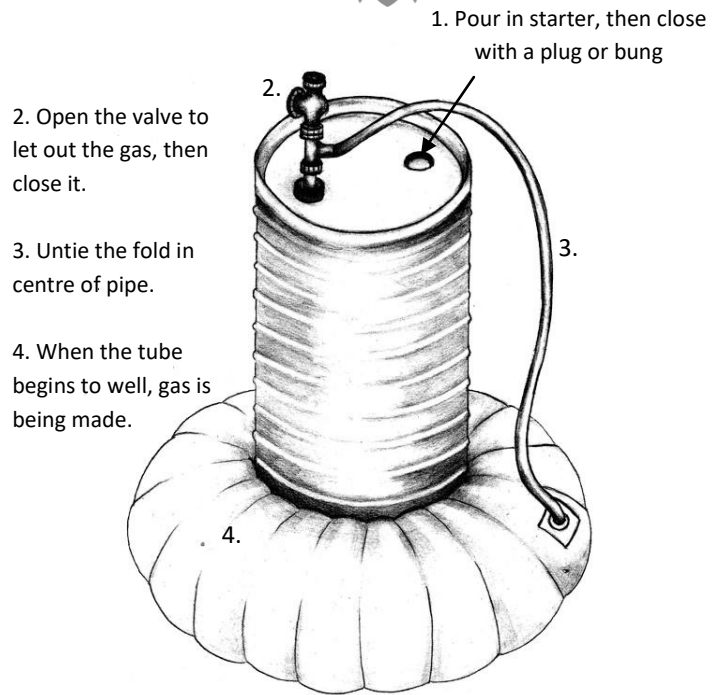

Figure 3-6: A simple design with rubber ring gas holder.

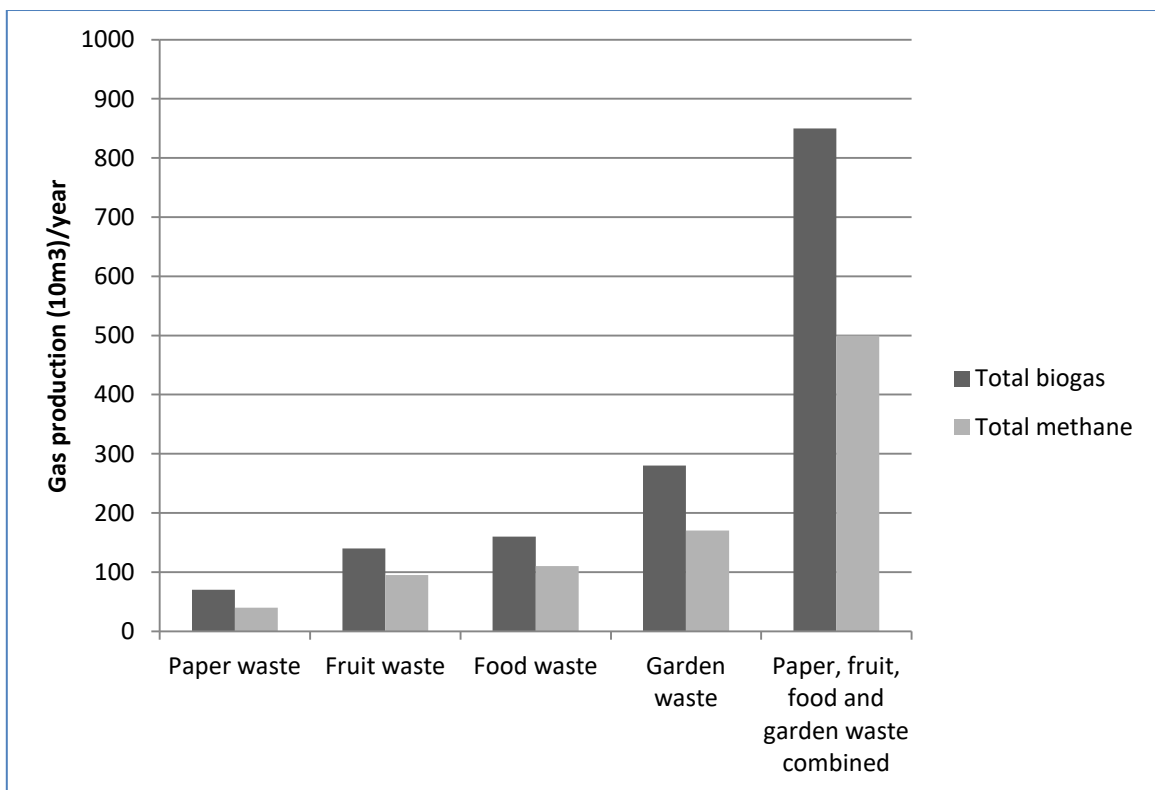

Figure 3-7: A bar graph showing the volume of biogas and methane that can typically be recovered from different types of organic waste in a tropical climate<sup>4</sup>. Biogas is a mixture of methane, carbon dioxide and other trace gases. Methane is the useful cooking gas.

<sup>4</sup> Getahun, Tadesse & Gebrehiwot, Mulat & Ambelu, Argaw & Van Gerven, Tom & Van der Bruggen, Bart. (2014). The potential of biogas production from municipal solid waste in a tropical climate. *Environmental monitoring and assessment*, 186.

### 3A How to build a tubular plastic biodigester

You can make a free cooking gas by digesting wet organic waste in a sealed chamber.



**Before you start, make sure you have read the introduction to How to convert organic waste to biogas, How-to guide 3.**



*Biogas is highly flammable. Make sure you have no naked flames or sparks near your biodigester.*

*Biogas can suffocate you in an enclosed space. Always make sure you work in a well-ventilated area and with at least one other person.*

*Animal dung contains bacteria, viruses and, possibly, parasites. When handling such material, use gloves and overalls and wash your hands afterwards.*

The tubular plastic biodigester was developed by CONDRIT in the 1980s. It is simple and cheap to build, and there are more than 7,000 in use in Colombia, Ethiopia, Tanzania, Vietnam and Cambodia. The design described here was developed by Rodriguez and Preston, University of Tropical Agriculture Foundation, Vietnam, published by FAO<sup>5</sup>.

#### **You will need:**

1. **Digester:** Transparent polyethylene (PE) tubular film, with a diameter between 80cm and 200cm (equivalent to a circumference of 2.5 to 6.3m). The thickness should be in the range of 800 to 1,000 (200 to 250 microns), although multiple layers of a thinner material can be used. The length of the tube is determined by the size of the biodigester (see calculations in Step 1). The most appropriate material is that which is used for greenhouses as this usually contains an ultraviolet (UV) filter which helps to prolong the life of the plastic when fully exposed to the sun. If this is not available you can shade the biodigester from the sun using a simple canopy.
2. **Inlet and effluent pipes:** 2 PVC tubes of 75 to 100cm length and 15cm internal diameter; 4 used inner tubes (from bicycle, motor cycle or motor car) cut into bands 5cm wide.
3. **Gas outlet:** 2m of PVC pipe of 12.5mm internal diameter; 2 PVC adapters (male and female) of 12.5mm internal diameter; 2 rubber washers (from car inner tube) of 7cm diameter and 1mm thickness with a 12.5mm diameter central hole; 2 rigid plastic (perspex) washers of 10cm diameter and a central hole of 12.5mm. Although perspex is best, these washers can be cut from different sources such as old plastic buckets and other materials made from strong plastic.

<sup>5</sup> Photographic instructions can be found by searching online for: "Biodigester installation manual" "FAO"

4. **Water trap:** 1 transparent plastic bottle; 1 PVC elbow of 12.5mm internal diameter; 3 PVC "T" pieces of 12.5mm internal diameter; 1 tube of PVC cement.
5. **Gas reservoir (optional):** 4m length of polyethylene tubular film; rigid PVC "T".
6. **Gas pipe to stove:** Plastic (PVC) hosepipe of 12.5mm internal diameter (the length depends on the distance to the kitchen).
7. **Fencing and shade:** It is very important to keep animals (and children!) from damaging the plastic film. A shade will prevent the plastic from degrading in the sun.

**Step 1: Prepare the trench**

1. Choose a location close to where the waste is produced, for example near to a livestock pen or kitchen. It is easier to use gravity to transport the liquid waste to the biodigester than to move it by hand.
2. Calculate the size of the biodigester (this example has a 4m<sup>3</sup> liquid capacity). The standard diameters of polyethylene (PE) tubular film are 80, 125 and 200cm. Here we will use a diameter of 80cm which gives a cross-section area of

$$0.4 \times 0.4 \times \pi = 0.50\text{m}^2$$

On average 80% of the total volume in the tube corresponds to the liquid fraction, so to accommodate a liquid volume of 4m<sup>3</sup> will require a biodigester with a length of

$$4 / 0.80 / 0.5 = 10\text{m}$$

The recommended dimensions of the trench which will hold a biodigester of the above dimensions are:

Width at top 90cm; depth 90cm ; width at bottom 70cm; length 10m

3. Using string attached to four posts, mark out on the land the upper extremities of the trench (in this example, 90cm\*10m). Dig the trench, making sure the sides and floor are smooth with no stones or roots that could damage the plastic film.

Dig the floor of the trench so that it has a slope of about 2.5% from the inlet to the outlet (for a 10m long biodigester, this would be 25cm). Move all the unwanted soil away from the trench so that it does not fall in and damage the plastic during construction or use of the biodigester.

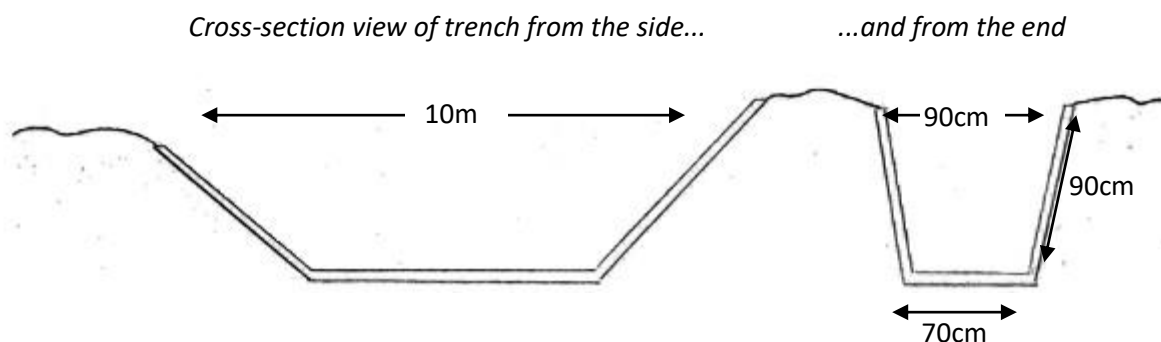

Figure 3-8: Cross-section views of the trench to dig for the tubular bag biodigester.

### Step 2: Prepare the tube

The polyethylene comes from the factory in long rolls, so you may have a lot leftover which you could sell to other communities. A roll is also quite heavy (a 100m roll of 80cm tube weighs about 50kg) so be prepared if you need to transport it. Keeping a metal or bamboo rod in the centre of the roll makes it easier to unroll the desired length. Be very careful that the plastic sheet is not punctured when it is moved. If necessary, cut off and discard any sections that have holes in them. Even tiny holes can leak gas.

Measure out the desired length (10m in this example) and add 75cm onto each end for wrapping around the inlet and outlet pipes. The length in this example is therefore

$$10\text{m} + 75\text{cm} + 75\text{cm} = 11.5\text{m}$$

Cut two lengths and put one inside the other to give strength. Make sure they fit snugly together and that there are no folds or creases.

### Step 3: Prepare the gas outlet

Mark the place where the gas outlet will be, about 1.5m from the end of the plastic tube and in the centre of what will be the top of the biodigester. Cut a hole the size of the external diameter of the PVC male adaptor.

Cut rubber washers from an old motorcycle or car inner tube. (Instructions for making washers can be found in How-to guide 3.2.)

Assemble the components, ensuring the male and female adaptors fit together smoothly.

Insert the male adaptor, complete with the plastic circle and rubber washer, from within the plastic tube. Then take the female adaptor, with the rubber washer and plastic circle attached, and screw it tightly onto the protruding male adaptor.

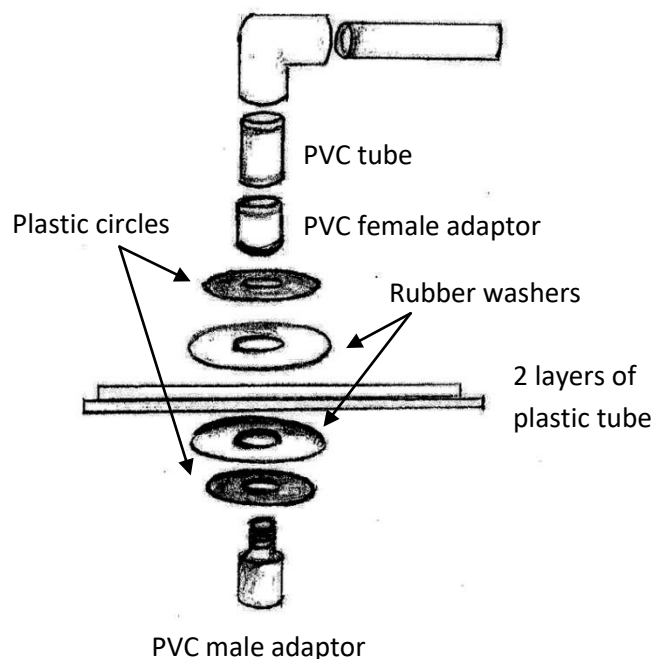

Figure 3-9: Prepare the gas outlet.

#### **Step 4: Fixing the inlet pipe**

Cut rubber bands 5cm wide from used inner tubes. Use protective sheeting on the ground below the work area to avoid damaging the plastic tube.

Insert the PVC pipe to one half of its length inside the plastic tube, and fold the plastic around it. Secure the join by wrapping the rubber bands around the pipe starting at 25cm from the edge of the plastic and working toward the exposed part of the PVC pipe, each band overlapping the previous one, and finishing on the PVC pipe so that the edges of the plastic tube are completely covered.

#### **Step 5: Filling the plastic tube with air**

Close the inlet tube with a plastic bag and a rubber band. Do the same to the gas outlet.

Fill the polyethylene tube with air before putting it in the trench. From the open end, force air into the tube by waving it up and down with your arms. Then tie the tube with a rubber band about 3m from the end so that the air cannot escape. This will make it easier to fit the outlet pipe, using the same process as for the inlet pipe.

#### **Step 6: Fix the outlet pipe**

Fit the second PVC pipe to the outlet of the plastic tube using the same procedure as for the inlet.

Make sure the edges of the plastic are completely covered by the rubber bands, overlapping each one, and ending on the PVC tube. Now close the end of the outlet pipe using a plastic bag and rubber band, and release the rubber band that was attached around the plastic tube. The bag will appear to deflate a little as air enters the end section that was previously closed.

#### **Step 7: Final preparations**

To completely fill the bag with air, attach a length (4m) of plastic tube (same material as used for the biodigester) to the PVC outlet pipe, filling this with air by the flapping procedure, and then remove the plastic bag sealing the end of the outlet pipe to allow this air to enter the main bag. Repeat this process until the biodigester bag is completely full of air. Reseal the outlet pipe with a plastic bag and rubber band. If the bag will not hold pressure, there is probably a hole in it and it may need to be sealed (see Hints).

Carry the inflated biodigester bag to the trench, making sure it does not get punctured by anything on the way. Lower the bag into the trench, with the gas outlet at the top of the tube. Prepare a support to hold the gas outlet line.

Secure the gas line (13mm internal diameter PVC tube) using PVC cement.

Fill the bag with water until the inlet and outlet pipes are covered with water from the inside. This traps the air inside the upper part of the bag. Remove the plastic bags over the inlet and outlet pipes.

**Step 8: The water trap (gas escape valve)**

Fit a gas escape valve along the gas line. This is important as it prevents gas pressure building up to dangerous levels.

***This simple but important device will prevent pressure building up in your system. Gas under pressure can be explosive.***

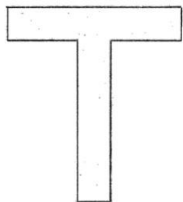

Prepare a "T" from three pieces of PVC pipe, two short pieces and a longer one which will fit into a used plastic bottle.

Figure 3-10: A "T" shape made from connecting two pieces of pipe.

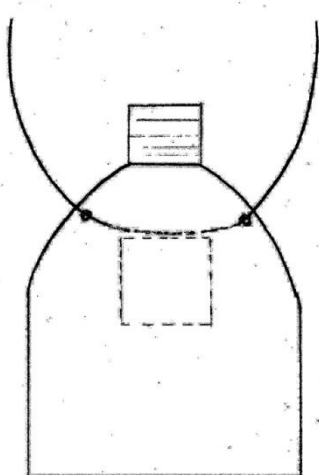

Cut a 3\*3cm hole in the upper part of the bottle, just below the neck, through which water will be added to form the gas seal.

Make small holes either side of the neck to take a length of thin wire to attach the bottle to a support structure.

Insert the PVC "T" inside the bottle and add water to 4-5cm above the lower part of the "T". Punch small holes into the sides of the bottle 2cm above the lower end of the "T". This ensures that if the gas pressure inside the system exceeds 2cm water column the gas can escape to relieve the pressure.

Figure 3-11: An air hole in the top of the bottle with a wire to hag it to a support structure.

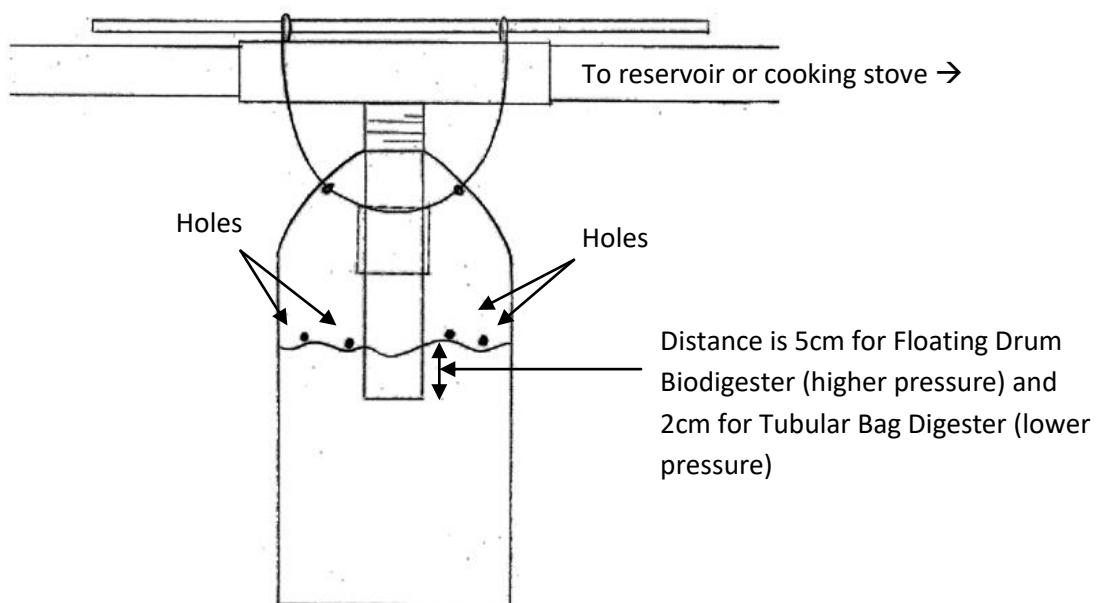

Figure 3-12: A completed water trap to allow the escape of high pressure gas.

Suspend the “water trap” in a convenient place so that the water level can be easily observed and replenished when necessary. Attach a flexible plastic pipe to the gas outlet and join to one arm of the other “T”. The other arm links with another plastic pipe which goes to the kitchen.

### Step 9: The gas reservoir

Use a 4m length of the same polyethylene tube used for the biodigester. Close one end using rubber bands from used inner tubes. Fit a “T” made from rigid PVC to the other end. Locate the reservoir in a convenient place (for example, suspended in the roof space), close to the kitchen. Connect the arms of the “T” to the gas line; the inlet to the digester and the outlet to the stove in the kitchen.

(If you need to cook faster, you can increase the pressure in the reservoir by tightening the string around it. Remember to loosen the string after cooking so the reservoir can fill up with more gas.)

### Step 10: Taking the gas to the kitchen

With the reservoir in place, attach the gas line from the outlet arm of the “T” to the stove.

Place a strap around the middle section of the reservoir. When you pull on the strap and tie it to a fixed object or a hanging stone or brick, you increase the pressure of the gas delivered to the burners. This is often necessary when cooking for a long time.

Depending on your feedstock, the biodigester should start to produce biogas within 5 to 28 days.

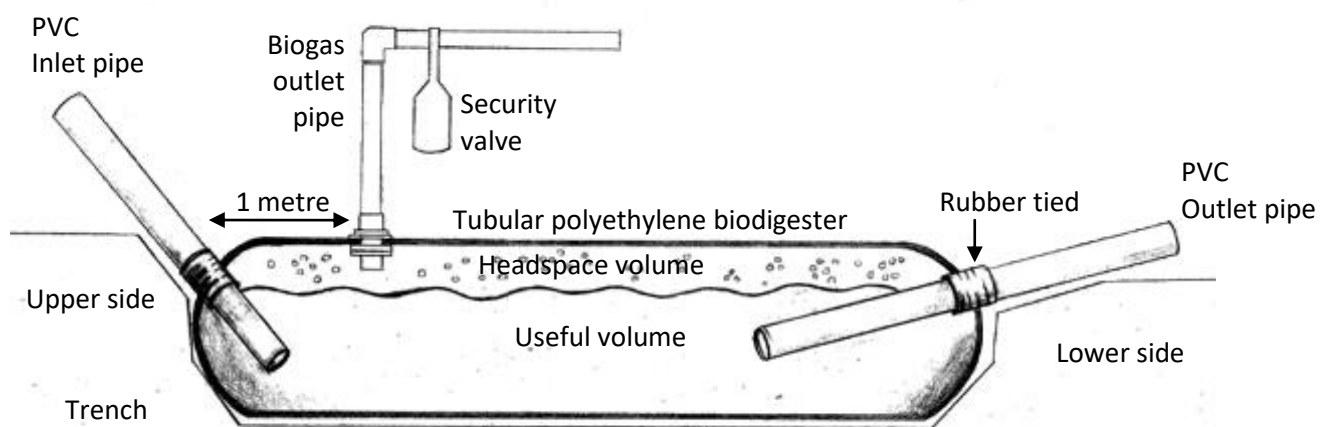

Figure 3-13: The tubular bag biodigester.

**Hint:** If the biodigester bags get damaged, patch the hole using male and female adaptors with washers big enough to cover the hole, and sealing the outlet of the adaptor. If the hole is too large to be mended, replace the plastic tubes and reinstall the system. Protect the digester with a fence to stop animals falling down. **Rats and other rodents like to bite plastic, so further protection may be required.**

**Hint:** If the slurry inside the biodigester becomes dry, replace the plastic tube of the biodigester. This is more likely to happen if you are feeding the biodigester with cattle manure. The bags will usually need to be changed every 2 to 4 years. Cut open the bags to remove the manure and mix with compost. Save a small amount to seed the new biodigester.



### 3B How to build a floating dome biodigester

You can make a free cooking gas by digesting wet organic waste in a sealed chamber.



**Before you start, make sure you have read the introduction to How to convert organic waste to biogas, How-to guide 3.**



*Biogas is highly flammable. Make sure you have no naked flames or sparks near your biodigester.*

*Biogas can suffocate you in an enclosed space. Always make sure you work in a well-ventilated area and with at least one other person.*

*Animal dung contains bacteria, viruses and, possibly, parasites. When handling such material, use gloves and overalls and wash your hands afterwards.*

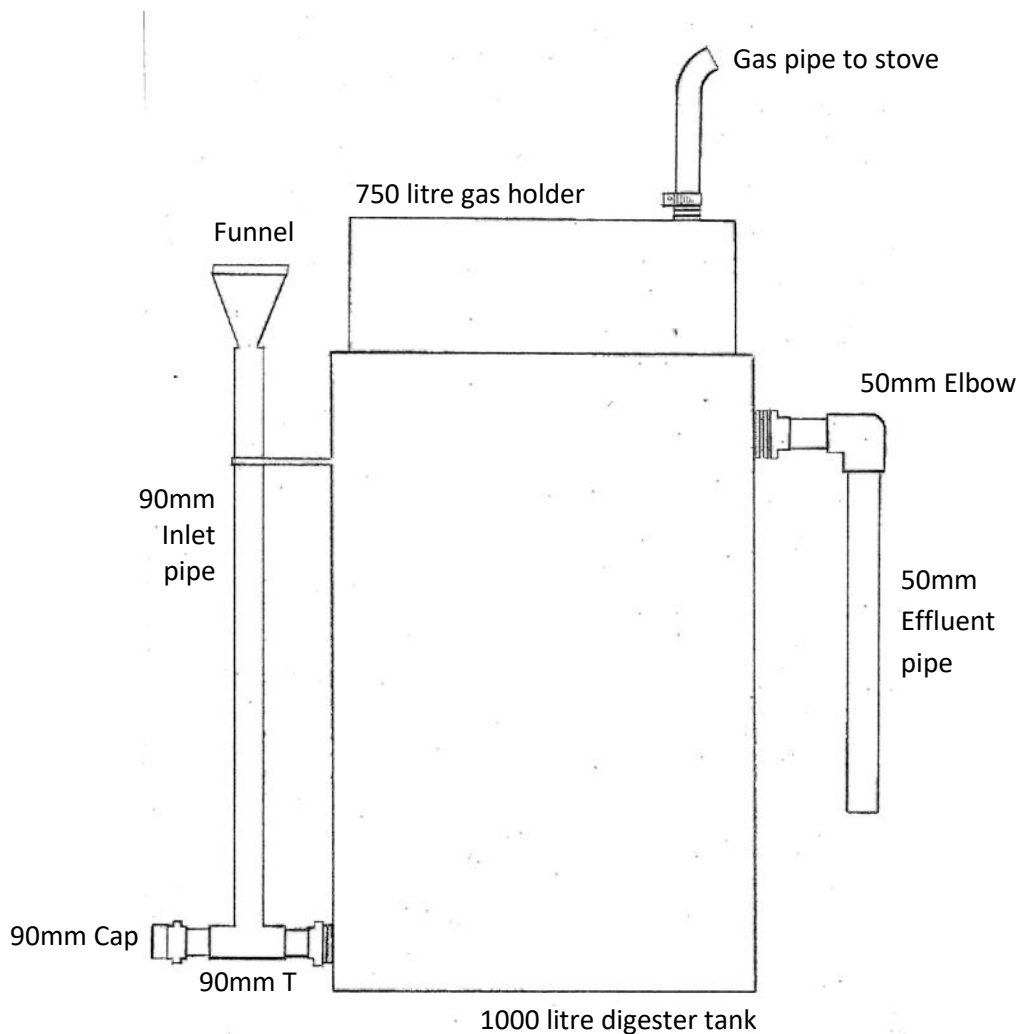

Figure 3-14: Floating dome biodigester.

This design was developed by Dr A.D. Karve of The Appropriate Rural Technology Institute (ARTI) in India. It is presented here with additional tips from EAWAG and AIDG<sup>6</sup>.

**Floating dome digesters: key facts** (*from Ashden*):

- About 50 million household-size plants are in use, in China, India, Nepal, Vietnam and elsewhere. Over 10,000 larger plants are used for electricity generation.
- Household plants are typically 1 to 12 cubic metres in volume, with the largest commercial plants reaching up to several thousand cubic metres.
- The cost of household plant varies greatly from country to country, but is typically around US\$550. If this cost is too high, a cheap alternative is suggested in *How to convert organic waste into biogas*, How-to guide 3. The techniques in this section, such as making your own washers, might be useful for incorporating into a simpler design.

---

<sup>6</sup> The Appropriate Rural Technology Institute (ARTI) [www.arti-india.org](http://www.arti-india.org); EAWAG [www.eawag.ch](http://www.eawag.ch); AIDG [www.build-a-biogas-plant.com](http://www.build-a-biogas-plant.com); Ashden [www.ashden.org](http://www.ashden.org).

**You will need:**

1. 1000 litre plastic tank (digester).
2. 750 litre plastic tank (gas holder).
3. Sheet of rubber for making washers (this can be an old bicycle inner tube).
4. Chisel, jigsaw, scissors, pipe wrench.
5. Inlet pipe: a 90mm diameter pipe, a little longer than the height of the digester tank, fitted into a 90mm "T" at the bottom and fixed loosely to the top of the tank, in upright position. This pipe will also serve as a purge if necessary. Small block (of wood, brick or concrete).
6. Funnel: fix to the top of the inlet pipe to pour in feedstock material.
7. Effluent outlet: fitted at the top of the digester tank. (Collect effluent liquid and use it to mix with fresh feedstock, or put on your compost heap.)
8. Gas outlet: brass valve fitted to the top of the smaller inner tank and directed toward a gas stove. Flex hose and PVC pipe.
9. Frame structure: built above the tanks to stop the gas tank falling out when too full. It is possible to put a weight on the upper tank to increase gas pressure in the tank.

**Step 1: Prepare**

*Cut the top of the big tank (the digester) so that the small tank (the gas holder) will fit inside it upside down. The big tank is cut so that its opening is the size of the small tank.*

1. Cut off the top of the small tank and place it, centred, on top of the big tank to mark its perimeter.
2. Draw another cutting line 4cm larger all around, so that the hole is 8cm wider in total.  
(Alternatively, measure the distance from the centre of the top of the small tank to the outside with a piece of string and add 4cm to the length of the string. Place the end of the string on the centre of the top of the large tank and use it as a guide to mark a circle.)
3. Cut the tank using a very sharp and strong knife at first, and then with a handsaw or jigsaw blade. Test to see if the smaller tank fits well. It should have 4cm space around the sides. File the edges so they are smooth.

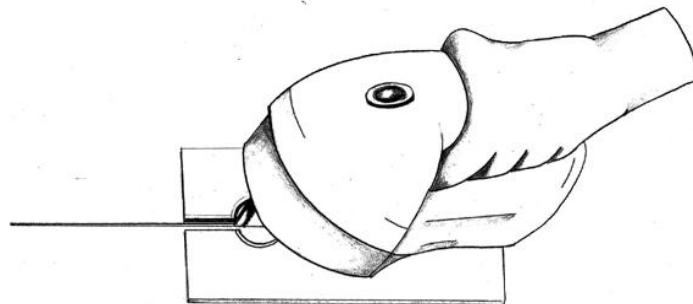

Figure 3-15: Cutting the plastic tank with a jigsaw.

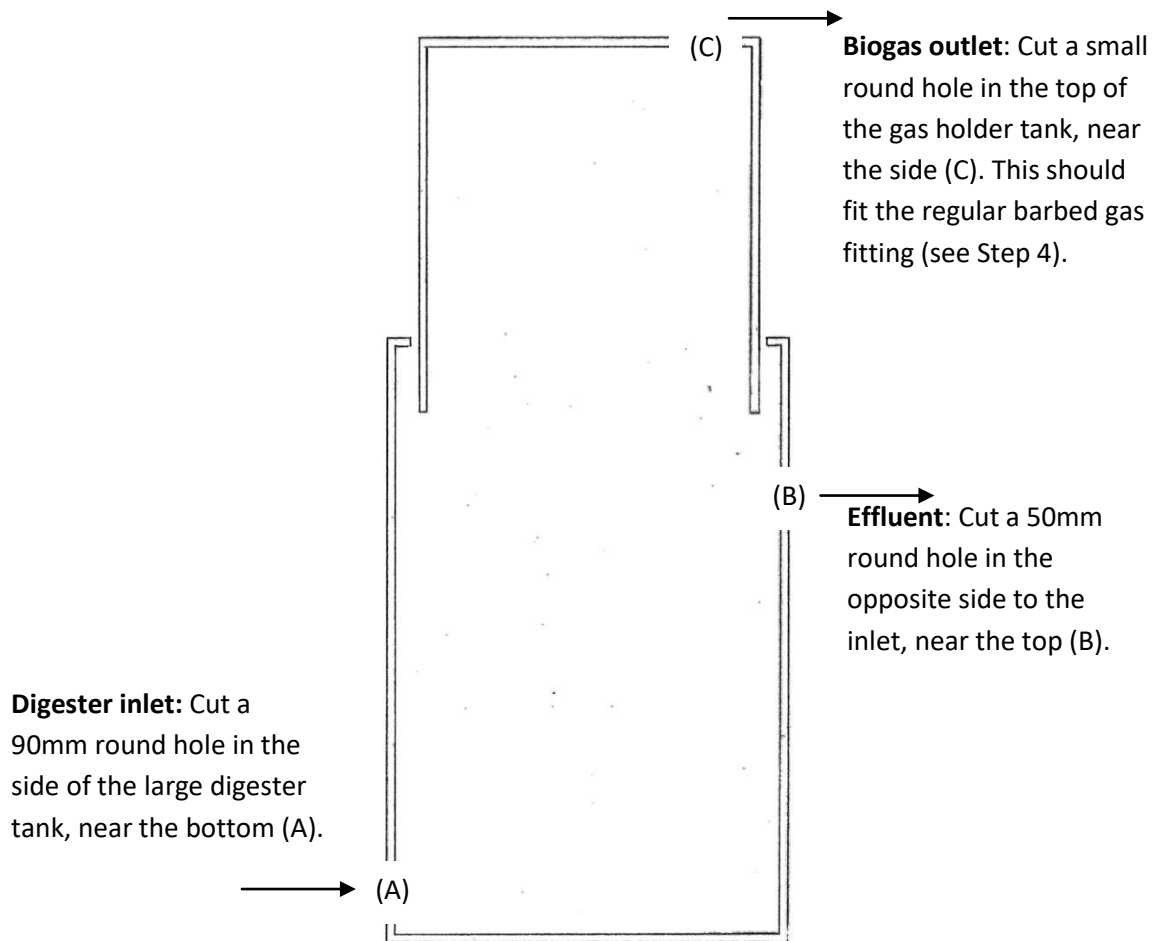

Figure 3-16: Prepare the tanks by cutting holes for pipe work.

**Rubber washers:** Make rubber washers to fit the pipe holes. Sit the pipe round end down on top of a sheet of rubber (this can be an old bicycle inner tube). Draw around the inside and outside of the pipe wall. Use scissors to cut the washer.

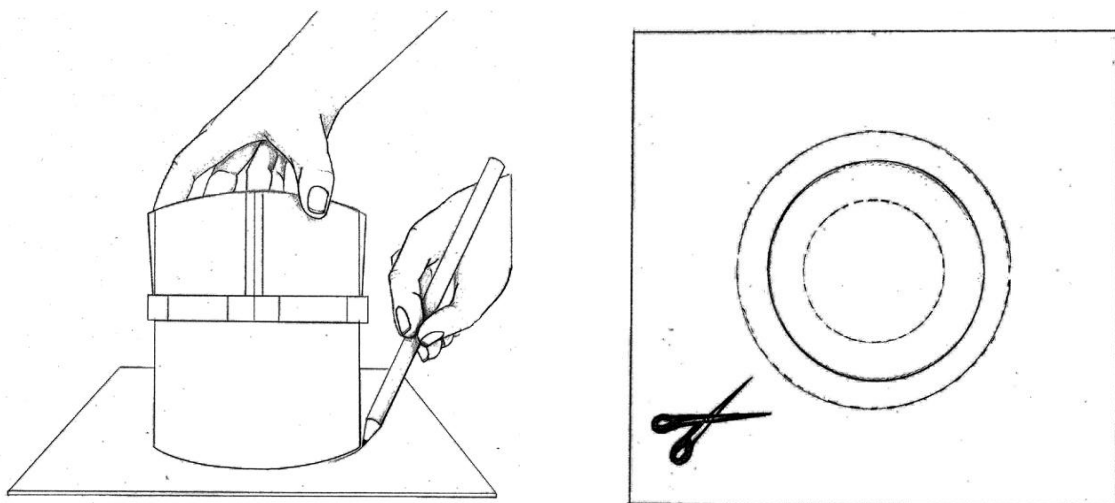

Figure 3-17: Make washers by cutting rings from rubber.

**Step 2: Assemble and fit the inlet pipe**

Fit 600x90mm pipe (A) into bottom of large digester tank (B) using an adaptor (C) to prevent leaks. It is helpful to push the end of the pipe through a block to keep it off the floor of the tank.

Fit 90mm plastic T pipe (D) in line, onto the outside of the fitted pipe. The cap (E) fits on the other end.

Fit the 1m pipe (F) onto the top of the T pipe so it stands vertically next to the tank. Attach (G) loosely to the side of the tank to stop it falling.

Fit the funnel (H) in the top of the vertical pipe.

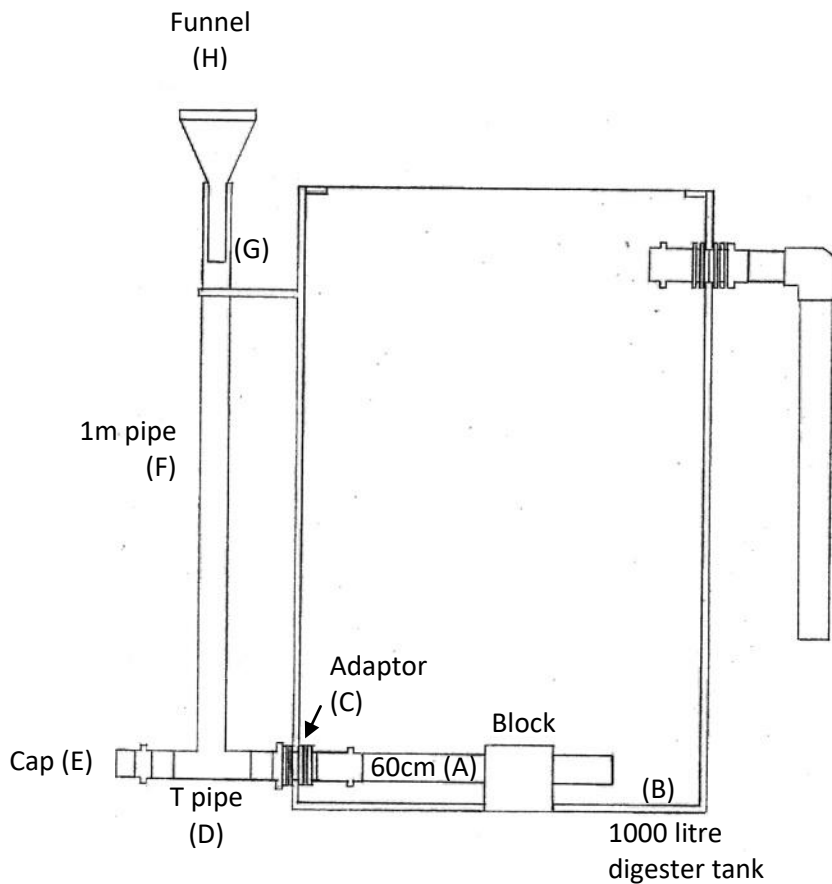
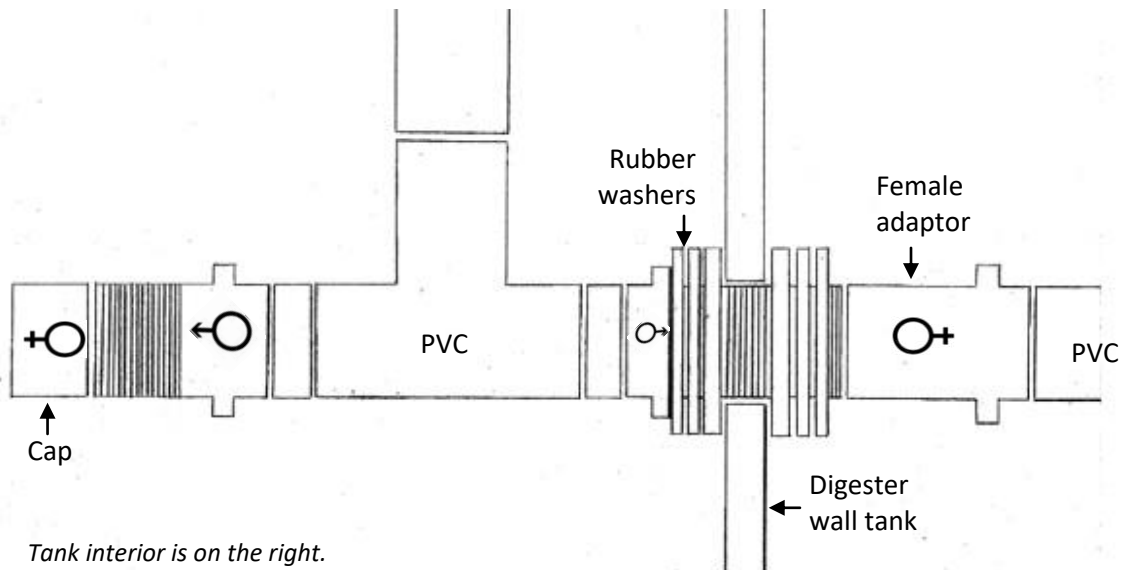

Figure 3-18: Assemble and fit the inlet pipe.



Tank interior is on the right.

There are two rubber washers and a thicker washer on each side of the tank wall.

Figure 3-19: Assemble and fit the inlet pipe (detail).

**Hint:** The inlet needs to be watertight. Use a male fitting for this section and screw it through the tank wall using a pipe wrench. Then use 2 rubber washers and 1 thicker, spongier washer on each side of the inlet. Use silicon to seal all the joints.

### Step 3: Assemble and fit the effluent pipe

Fit the 200x50mm pipe (I) into the side of the tank using an adaptor (J) to prevent leaks.

Seal the effluent outlet with washers on the inside and outside of the tank. Fit the 50mm elbow pipe (K) and the vertical effluent pipe (L) onto the end.

**Hint:** The length of pipe on the inside of the tank should be short, to allow enough space for the gas holder to fit inside the digester tank.

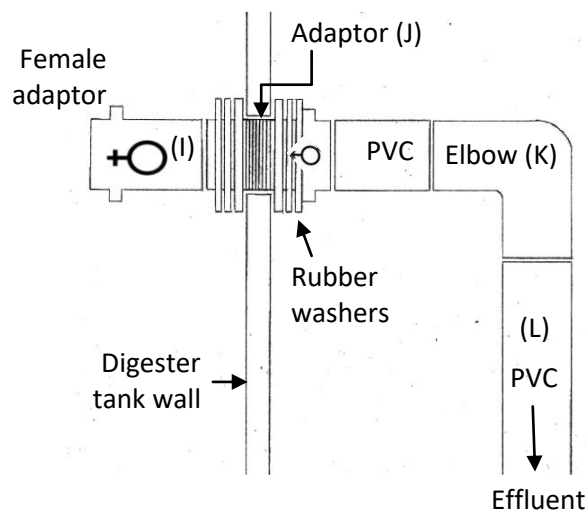

Figure 3-20: Assemble and fit the effluent pipe (detail).

**Step 4: Assemble and fit the biogas pipe**

Attach the gas line (A) to a regular barbed fitting (B) and secure with a hose clamp (C).

Sandwich the tank wall (D) between two washers (E) and (E) and nuts (F) on the threaded end of the fitting.

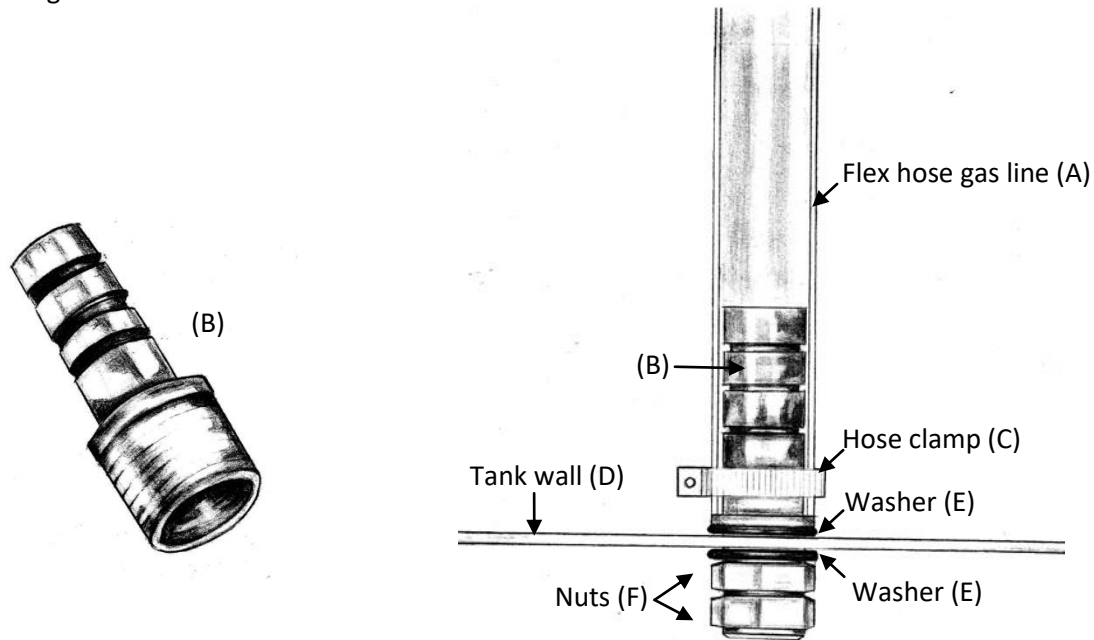
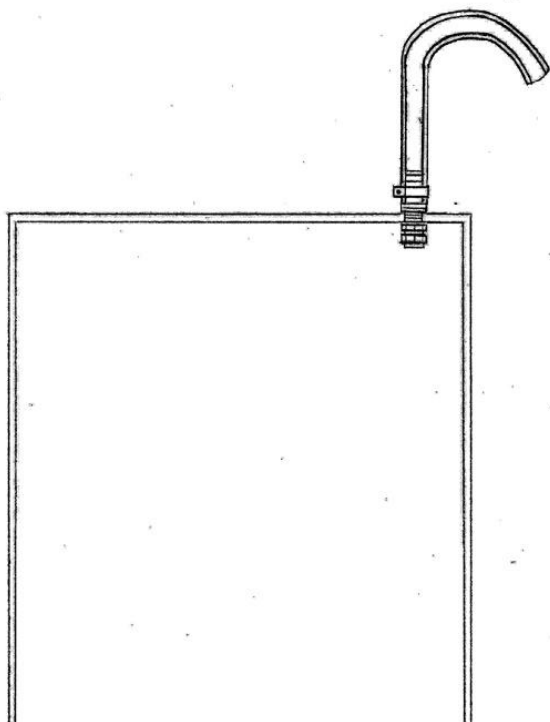

Figure 3-21: Assemble and fit the biogas pipe.



**Hint:** The gas line is a standard flex hose, which can be transitioned to a standard PVC gas pipe and buried underground. Burying the PVC line protects it from degrading in the sun and developing cracks that could cause gas leaks.

Figure 3-22: The gas line is a standard flex hose.

### **Step 6: Assemble the structure**

Fit the gas holder (smaller) tank inside the digester (larger) tank.

To increase the gas pressure to a usable value, place a weight (for example a couple of bricks) on top of the floating drum. The height the tank rises will depend on the amount of gas in the holder. The pressure will vary very little as the tank rises. To make sure the gas tank stays in place, even when full of gas, use three lengths of 2cm PVC pipe connected together with 90° elbows to form inverted 'U' shapes (140cm, 129cm, 140cm.) Build two of these. Connect the two structures over the biodigester in an 'X' formation.

### **Step 7: Start the system**

Start the system by loading it with about 20kg fresh cattle dung (not more than 6 days old), waste flour or starch and water. The bacteria from the cow's intestine, and consequently in the dung, are the bacteria that break down organic material into biogas (methane and carbon dioxide).

After 2 weeks, the system should start to produce gas and the upper tank will rise.

Test the gas by burning it: if it is combustible you can start to add high calorie material (see *How to convert organic waste into biogas*, How-to guide 3).

### **Step 8: Maintain the system**

Each day, feed the system with 1-1.5kg feedstock mixed with 10 to 15 litres of water in the morning and again in the evening. Mash up any feedstock that has large lumps (of more than 2cm) so that it resembles a smooth soup.

The digester should provide a steady supply of gas, typically 250-500 g of gas per day from 1 kg (dry matter) of feed. Biogas is 1.15 kg / cubic metre, so to store this amount of gas would require a gas holder or reservoir with a 0.28-0.56 cubic metre capacity.

See *How to convert organic waste into biogas*, How-to guide 3, for maintenance and troubleshooting.



**Step 9: Using your biogas**

You may need to make adjustments to your gas burner to make the flame burn consistently. The methane / air mix is fairly critical, and this will vary depending on your feedstock. If the flame is yellow or producing black soot, increase the air so that the flame has more heat. More detailed designs for biogas cooking stove modifications can be found on the internet<sup>7</sup>.

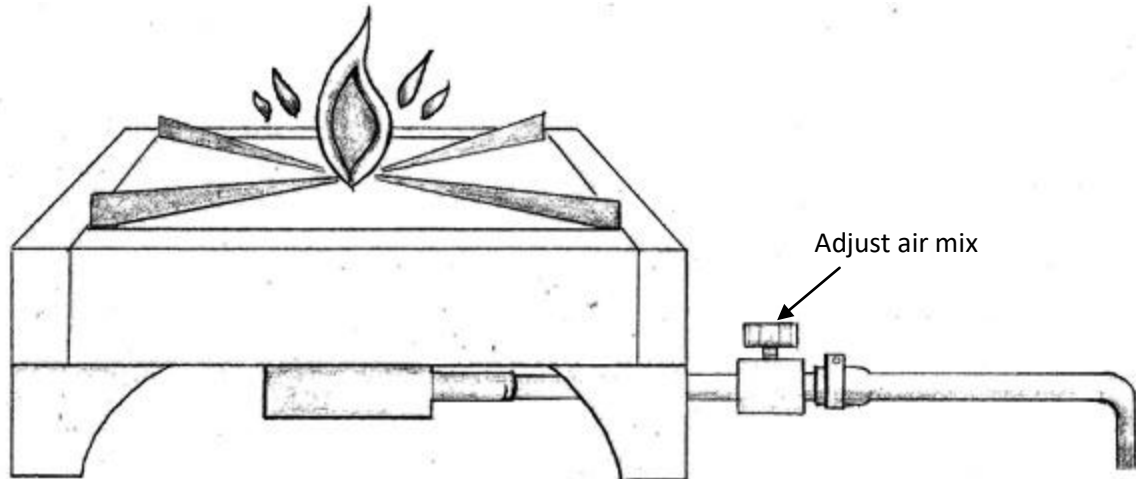

Figure 3-23: The biogas can be fed directly to a kitchen burner.

When your biodigester is working well, you should have enough gas every day to cook an evening meal.

Digester capacity	500 litres	1000 litres	2500 litres
Gas holder capacity	400 litres	750 litres	2000 litres
Available gas	250 litres	700 litres	1750 litres
Duration of burning	1 hour	2 hours	5 hours

Figure 3-24: The amount of gas generated from different size biodigesters (Source: ARTI).

<sup>7</sup> Fulford, D. (1996) Biogas Stove Design. Available at <http://kingdombio.com/BiogasBurner1.pdf>

#### 4. How to transform fish waste into animal feed

*Fish waste is very rich in protein – you can make it into supplements for animal feed.*

**Summary:** Collect **fresh** fish waste – what is left over after filleting. You can smoke and dry these, adding extra smoked fish meat for a higher quality product (Class 1), and then put through a milling machine.

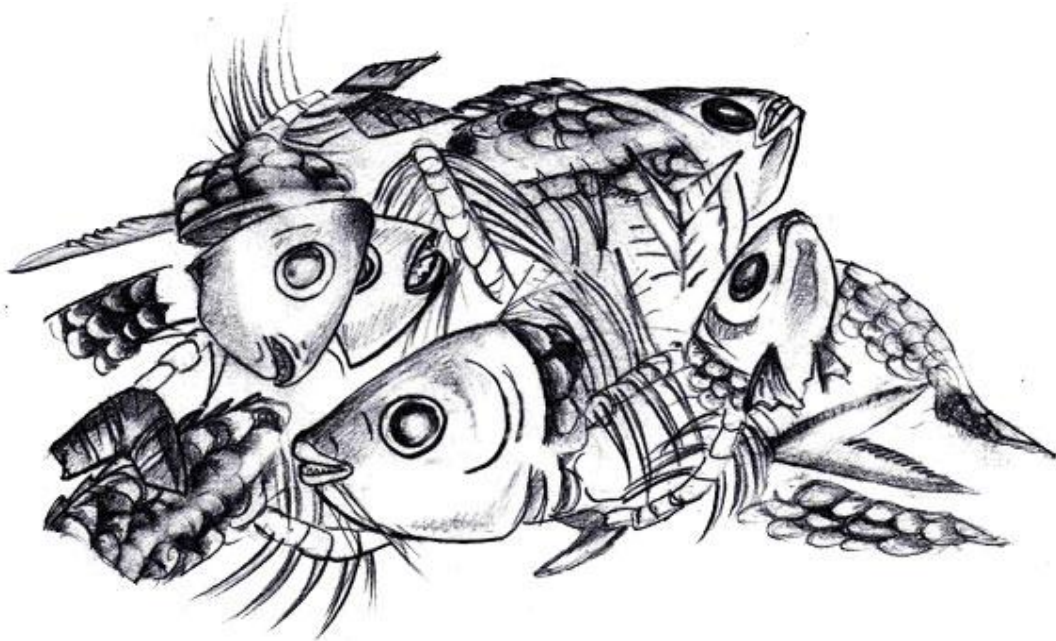

**Waste materials:** Fish heads, bones and tails.

**Product:** Protein supplement for animal feed.

**Benefits:** If you have access to farmers who keep animals, you can produce a nutritious animal feed. This increases productivity, is very good for young animals and is suitable for chickens, pigs, goats, cows and farmed fish. It is also useful as an alternative when there is no grass or fodder, particularly during the dry season.

**Hint:** If you don't have a market for your animal feed an alternative is to turn fish waste into very high-quality manure that is good for the soil and for plants (see *How to turn organic waste into compost*, How-to guide 5). You can use this soil conditioner on your own land or you can sell it to others.



*This activity produces smoke and odour so choose a suitable place well away from houses.*

*The fish waste can harbour disease and attract flies. Always process the material quickly and wash your hands afterwards.*

*Even after you have smoked the fish waste, it may still carry disease so always wash your hands after handling it.*

**You will need:**

- Overalls, gloves, masks, covered shoes or boots
- Smoking oven
- Firewood
- Access to a milling machine.

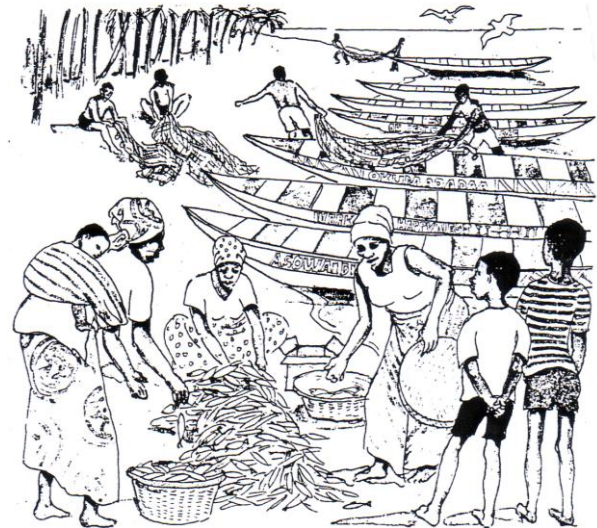

**Class 1 animal feed – the best quality**

For the best quality feed only use heads, bones and tails, mixed with whole fresh fish. **Do not use fish guts** – these can be used to make excellent quality compost instead (see How-to guide 5).

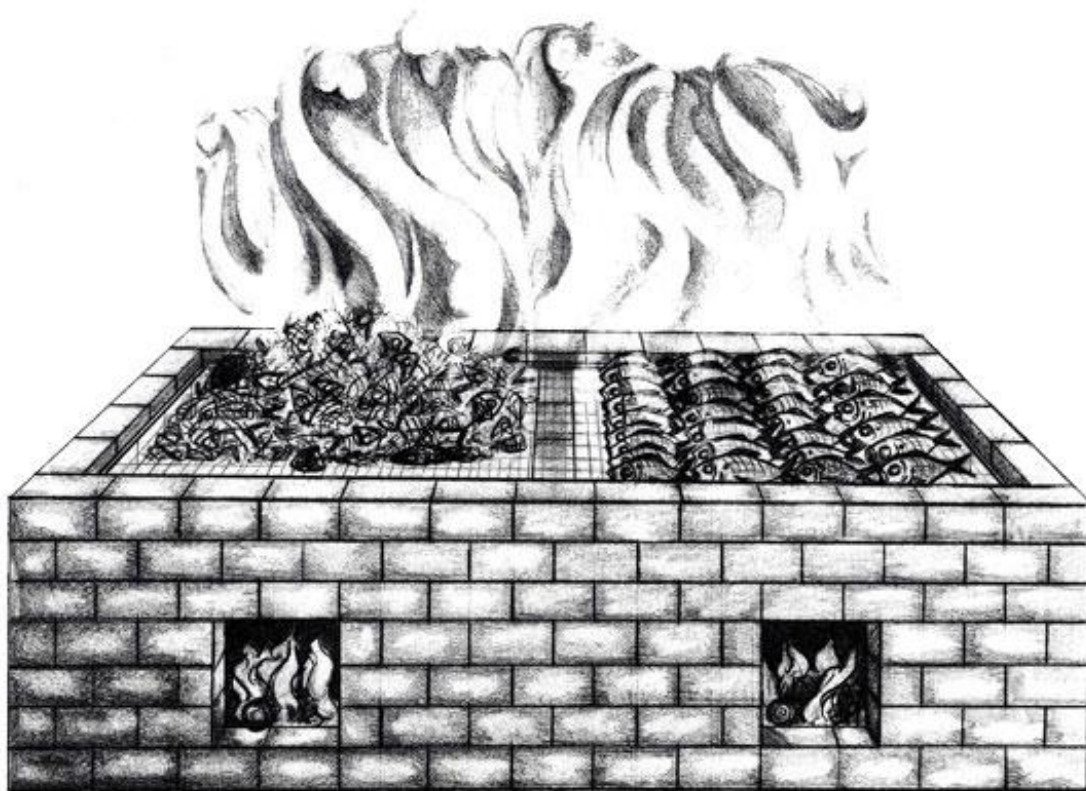

Figure 4-1: Class 1 animal feed is a mix of fish bones and whole fresh fish, smoked.

1. Collect fish waste (skin, heads, bones and tails), and an equal amount of whole fresh fish, and smoke for one day.
2. Dry for two days over a drying kiln.
3. Pass through a milling machine.
4. Add to grain to supplement other animal feeds.

### Class 2 animal feed

1. Collect fresh fish remains (skin, head, and tail) and smoke for one day.
2. Dry for two days.
3. Pass through a milling machine.
4. Add to grain to supplement other animal feeds.



Figure 4-2: Class 2 animal feed is made by smoking and milling fresh fish remains.

## Building a smoking oven

You can build a smoking oven using different materials, depending on what is available in your area:

1. Clay mud, packed and shaped by hand (85-95 “headloads” or basins for one oven).
2. Packed clay mud faced with cement (1/2 bag).
3. Clay mud blocks (sun-dried or baked) and mortar.
4. Cement blocks with mortar (requires 3 to 4 bags of cement and sand that is well-washed).



## Oven design

The ovens are rectangular, about twice as long as wide; with two stoke holes in the front. Preferably there is a foundation sunk in the ground and a dividing wall in the middle, both being recent improvements on earlier models.

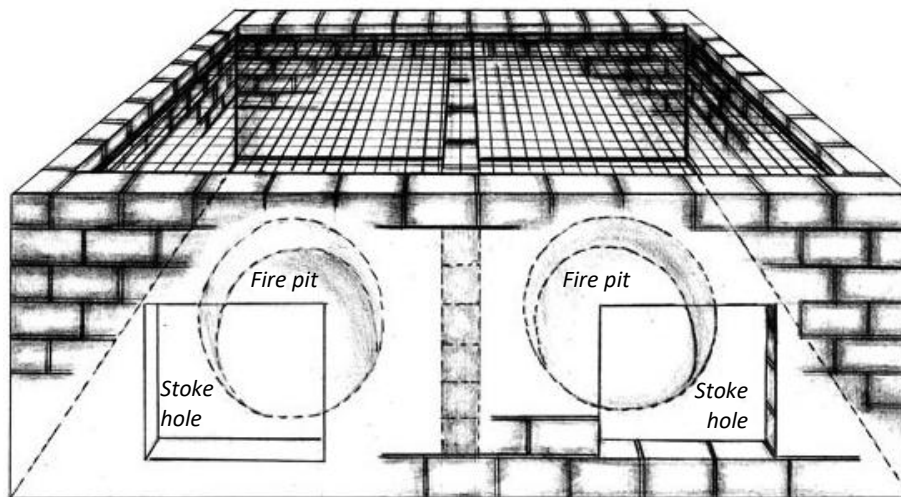

Figure 4-3: Example of smoking oven showing stoke holes and inner fire pits.

Advantages of middle wall:

- Gives added strength to the oven
- Protects the median cross piece of the bottom tray from burning
- Gives greater support to the loaded trays
- Allows for smoking of small quantity of fish over just one chamber, using less wood.

## Process

1. Clear and level the ground. Draw the outline of the oven walls. Dig a trench 15-20cm deep for the foundation.
2. Prepare the materials (delivery of clay soil or blocks); if loose clay, mix with water and pound until it becomes malleable and sticky.
3. Construct the walls in layers (if clay mud, do it in three stages – first pack the lower layer and allow to dry, then the next 40%, and finally pack and square the upper surface). This takes three days for packed clay ovens, or two days for block construction.
4. For the clay oven, cut stoke holes in the front wall once it is dry (with any sharpened strip of iron); wet the area to be cut first.
5. For the cement oven, make an arch with a piece of scrap plywood, and pack with cement well-bonded to the blocks surrounding it.
6. Finally, after the oven and stoke holes have dried, plaster with clay or cement.

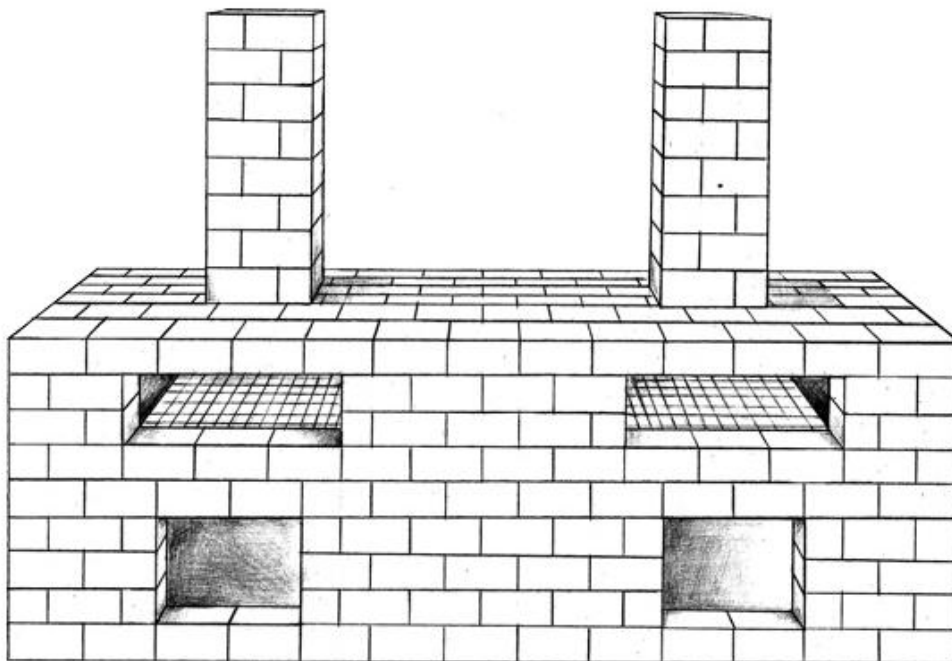

Figure 4-4: A different smoking oven design with chimneys, to help direct the smoke away.

## Drying fish

There are several ways to dry fish and there might be a traditional method where you live. If it is hot and dry you can simply dry the fish in the sun.

For the drying kiln table:

- Firebricks and cement or clay or mud if these are easily available
- Rebar
- 1cm metal mesh.

## Grinding and milling

If you do not have access to a milling machine, you can grind the animal feed into a fine powder using traditional tools.



## Marketing ideas

You can probably sell Class 1 feed for more, but it costs more to make as you have to buy fresh fish. You should see whether you can make more profit from Class 1 or Class 2.

Chickens fed with fish supplement make much richer eggs – talk to egg producers to see if they will buy your product.

This product can also be used as fish feed in fish farms. It can be added to smoked cow bones, oyster shells, palm nut, groundnut, maize and semolina to make high-protein animal feed.



## 5. How to turn organic waste into compost

*Waste from plants and animals can be used to make compost. Composting is a natural process that recycles organic material into a soil conditioner that improves soil quality and increases food yields.*

**Summary:** Composting is the natural breakdown of organic materials through mixing with oxygen from the air to form a stable, soil-like material.



**Waste materials:** Food waste, agricultural waste, animal dung, used animal bedding, wood chips.

**Product:** Chemical-free soil conditioner / compost.



***To produce a quality product, always use clean materials which have been kept separate from other wastes at the source.***

### Benefits:

- **Compost increases organic matter in the soil.**
- **Higher yields** – increasing the amount of organic matter and plant nutrients in the soil can improve crop yield potential.
- **It can be used, at least in part, instead of expensive inorganic fertilisers** – compost contains slow release, crop-available nutrients, including nitrogen, phosphorus and potassium. It also contains plant micronutrients such as magnesium and sulphur.
- **Better soil structure and water management** – compost improves soil structure, which improves water infiltration and retention and is good for crops.
- **Inhibiting pests and diseases** – the organic action of compost can help to inhibit pests and diseases within the soil.
- **Fuel savings and traffic tolerance** – compost improves soil structure, making it easier to work with. If you are using a rotavator or tractor it will use less fuel. Improving soil structure will make it more resistant to compaction from tractors and will extend the conditions in which it can be worked.



## Key Ingredients: Carbon and Nitrogen

The fastest way to produce compost is to use about two parts of green material to one part of brown material. This will ensure that there is the correct balance of nitrogen and carbon for the composting microbes to work.

If there is too much carbon, the composting process will be slow. If there is too much nitrogen you may end up with a smelly pile. It is important that air gets into the pile to help it decompose quickly, therefore aim to ensure that the pile has enough structure.

The compost should be slightly moist. If it is too dry, add a small amount of water and mix in.

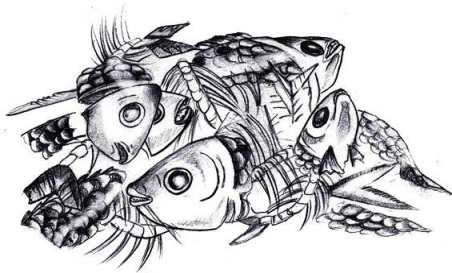

**NITROGEN-rich material (green):** Smelly organic waste such as animal dung, fish heads, bones and guts, green grass and leaves.



**CARBON-rich material (brown):** Woody organic waste such as small branches, dry leaves, coconut husk and groundnut shell.

Figure 5-1: The correct balance for composting is about two parts of nitrogen-rich material (green) to one part of carbon-rich material (brown).



*Composting is generally a safe activity, but:*

*There can be a risk from disease from the compost heap. You should always wear gloves when handling compost and wash your hands afterwards.*

*There can be spores from fungus in the compost heap. People with breathing problems should avoid turning compost heaps. Do not open a bag of compost with your head right over it. Damp down compost before use. It is advisable to use a mask when handling dry compost.*

There are many ways to build a good compost heap. It needs to be protected from the wind and preferably not able to dry out too much.

Two different types of compost heap are described here: the Triple Pit, and the Layered Cell.

**Triple Pit Compost**

Dig three pits in the ground. Place the mixture (two parts green material and one part brown material) in the first pit.

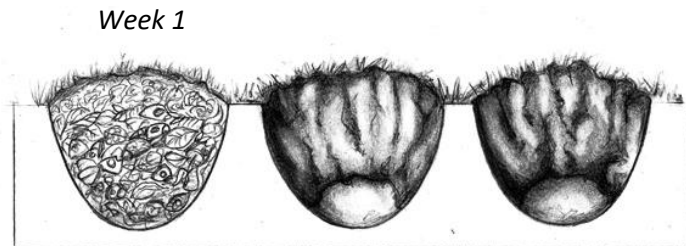

After a week, remove the material and put it in the next hole, mixing it up. This helps air reach every part of the compost and speeds up the process.

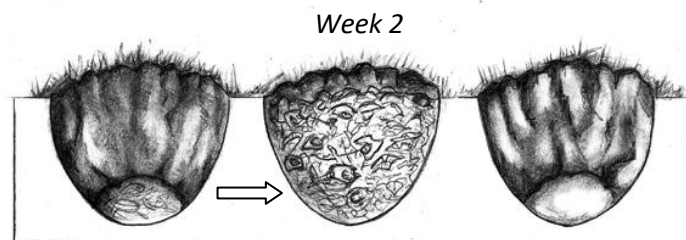

After another week, move the material to the third pit.

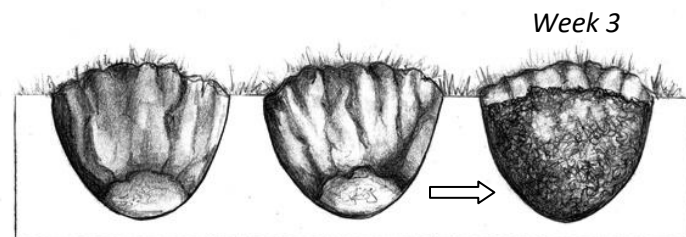

Finally, move the compost into a small heap at the side to allow it to 'mature' for a few more weeks. It will be ready when it smells earthy and looks brown, usually within another 6 or 7 weeks.

Figure 5-2: Triple pit composting.

You can be composting material in all three pits at the same time, each pit one week older than the next.

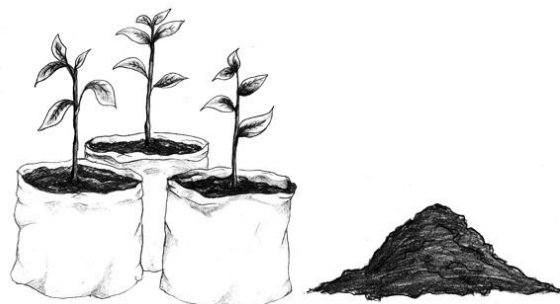

### Layered Cell Compost Heap

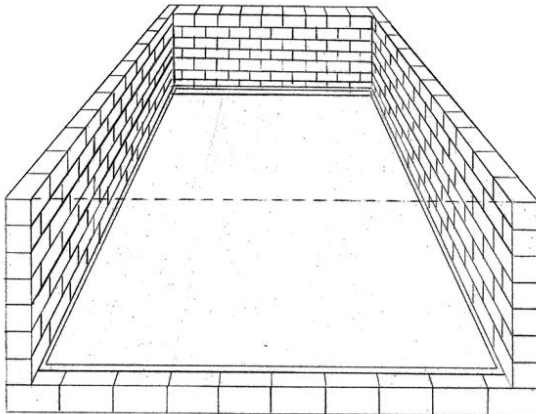

Build a cell (as shown in the picture). You can build it on the ground, or raised up on legs to keep vermin out.

Figure 5-3: The size of your composting cell will determine how much organic waste you can compost.

On the bottom layer, put branches and twigs or groundnut shells to improve air circulation and drainage.

Then put a middle layer of mixed 2 parts nitrogen-rich material (green) and one part carbon-rich (brown) material.

If it is particularly smelly or likely to attract pests, add a layer of finished compost over the top. Leave for 6 to 8 weeks, making sure it does not dry out.

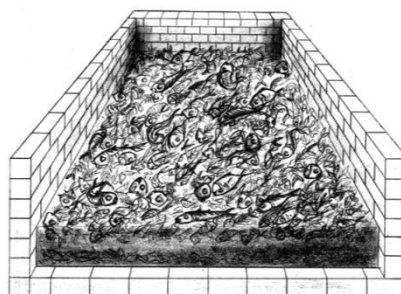
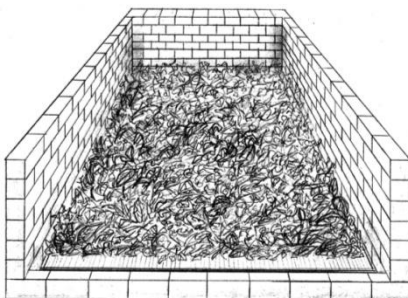
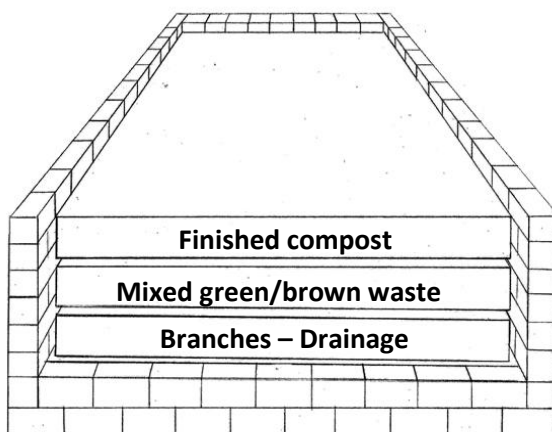

Figure 5-4: The layered cell composting process.



After 6-8 weeks, sieve the compost to remove any large un-composted parts, which go back in the hole/cell to compost for next time.

Allow the composted parts to mature for around 3 more weeks before using.

It will be ready when it smells earthy and looks brown.

Figure 5-5: The completed layered cell composting heap.

## Marketing and selling compost

If you want to sell your compost to farmers or gardeners, you should sieve it. You may have to give away free samples to convince people that something made from 'waste' will be good for their crops. One way of convincing them is to grow a market garden on your site using your compost to demonstrate how well it works.

Talk to farmers and agricultural stores to see how much people pay for imported compost. Can you supply yours at a lower price?

Remember to explain the benefits of using compost, from the beginning of this How-to guide.



## More help and advice

There is plenty of information on the internet to help you produce high quality compost. These resources are free to access:

- [Master Composter Manual](#) (1998). Cornell Waste Management Institute.
- Ali, M. et al. (2004) [Sustainable Composting: Case studies and guidelines for developing countries](#). WEDC, Loughborough University.
- Rouss, J. et al. (2008) [Marketing Compost: A Guide for Compost Producers in Low and Middle-Income Countries](#). SANDEC/EAWAG.
- Rynk, R. (1992) [On-Farm Composting Handbook](#). Northeast Regional Agricultural Engineering Service, Cooperative Extension (607) 255-7654.

## 6. How to turn organic waste into compost using worms

*You can make very high-quality compost quickly in a small space using special worms.*

**Summary:** Composting using worms, also known as vermicomposting is the process in which worms turn organic wastes into very high-quality compost very quickly.

**Waste materials:** Organic materials, especially food waste.

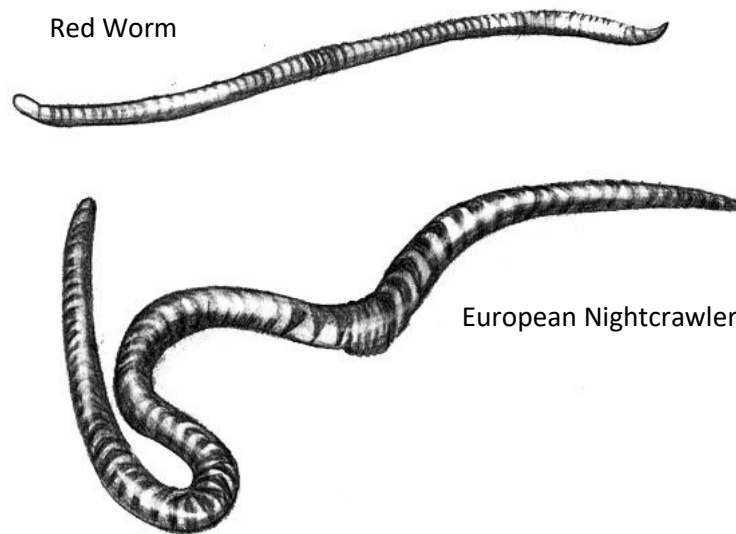

**Product:** Worm cast compost – also known as vermicompost. This is very high quality compost, suitable for kitchen gardens and agricultural uses.

**Benefits:** Worms can consume large amounts of organic waste, equivalent to their own body weight per day (1 kg of worms can consume 1 kg of “food” every day). The excreta or “castings” of the worms are rich in nitrate and available forms of phosphorus, potassium, calcium and magnesium. (See *How to turn organic waste into compost*, How-to guide 5 for the benefits of compost.) This type of composting is quicker and the box method uses very little space indeed, so it may be useful in a small compound or campus, or in urban areas where space is limited.



***To produce a quality product, always use clean materials which have been kept separate from other wastes at the source.***



*Composting with worms is generally a very safe activity, but:*

*There can be a risk from disease from the compost heap or the organic waste you are adding to it. You should always wear gloves when handling compost and wash your hands afterwards.*

*There can be spores from fungus in the compost heap. People with breathing problems should avoid turning compost heaps. Do not open bags of compost with your head right over it, and damp down compost before use. If the heap is dry wear a facemask to protect your lungs from the dust.*

### **Choosing the right worms**

Not all worms are suitable for worm composting (sometimes called vermicomposting). Good vermicomposting worm varieties:

- Can live in dense colonies
- Prefer making their home in airy bedding material instead of soil
- Reproduce quickly
- Have a big appetite for decaying organic matter.

Examples of good vermicomposting worms are: Red / Tiger Worm (*Eisenia Fetida*), European Night Crawler (*Eisenia Hortensis*), African Night Crawler (*Eudrilus Eugeniae*), West African Earthworm (*Hyperiodrilus africanus*), Blue Worm (*Perionyx Excavatus*), Alabama Jumper (*Amyntas Gracilis*) and Dendrode (*Dendrodrilus Rubidus*).

It is better to identify your local species because importing them can be costly, and many worms can die in transport. Introducing foreign species can also be harmful to the local ecology. Ask farmers if they know about any locally available worms, and experiment with different varieties.

Make sure you feed your worms the correct “food” and keep them at the right temperature and moisture.

### **Choosing the right vermiculture system**

There are several simple systems – we will look at two:

- The box method, suitable for a single or small number of households, and
- The pit method, suitable for community-scale vermicomposting.

## The box method

*This is suitable for smaller or household scale projects. You could also use this to breed more worms.*

1. Find a suitable bin or box – an old drawer from furniture, any wooden box or plastic container – approximately 40cm x 60cm x 20cm or 10 gallons. Make sure the box is clean by rinsing it with clean water to remove any residues which may be harmful to the worms. For wooden boxes, line the bottom and sides with plastic.
2. Prepare the bedding. Instead of soil, use moist newspaper bedding. Like soil, newspaper strips provide air, water, and food for the worms. Using about 50 pages, tear newspaper into 1cm to 2cm strips. Place the newspaper strips into a large plastic waste bag or container. Add water until the bedding feels like a damp sponge, moist but not dripping. Add dry strips if it gets too wet.
3. Add the strips to the box, making sure the bedding is fluffy (not packed down) to provide air for the worms. The box should be 3/4 full of wet newspaper strips.



Figure 6-1: The box method of worm composting.

4. Sprinkle 2-4 cups of soil into the box. The soil introduces beneficial microorganisms, and gritty particles to aid the worms' digestive process. Potting soil or soil from outdoors is fine.
5. Weigh your worms and then add them to the box. If you can't weight them, put them in a measuring jug and record the volume (e.g. 300 ml worms or one cup of worms). This is important for record-keeping and will help you know how much to feed them.



Figure 6-2: Add worms to the compost box.

6. Bury food scraps under the bedding. Feed the worms fruit and vegetable scraps that would normally be thrown away, such as peels, rinds and cores. Limit the amount of citrus fruits that you place in the box. **Do not add meats, bones, oils or dairy products.** Cut or break food scraps into small pieces: the smaller, the better.
7. Measure the amount of food. Feed worms approximately 3 times their weight (or volume) per week. Monitor the box every week to see if the worms are eating all the food. Adjust feeding levels accordingly. (If you start with 300 ml of worms, add 900 ml of food per week.) Bury food scraps in the box. Lift the bedding, add food scraps; then cover food with the bedding.
8. Place a full sheet of dry newspaper on top of the bedding. This will help maintain the moisture balance, keep any possible odours in the box, and help prevent fruit flies from making a home in the box. Replace this sheet frequently if fruit flies are present, or if box gets too wet.
9. Cover and choose a spot for the box. Cover the box with a lid made of plastic, plywood or cloth, but leave the lid ajar so the worms receive some air. If desired, you may drill holes into the box. Place the box away from windows and cook stoves (this will help the temperature stay stable).
10. **Feed, water and fluff!** To keep worms happy, feed them about once a week. If the bedding dries up, spray with water. (If bedding gets too wet, add dry newspaper strips.) Fluff up bedding once a week so the worms get enough air.
11. To harvest the worms – empty 2/3 of each box for adding to the compost pit. Add bedding material to the remaining 1/3 in the box – these will multiply again.





### The pit method

*This is suitable for medium to larger scale projects.*

1. Dig a series of pits around 3m x 4m x 1m deep with sloping sides. (Vary the number and size according to the amount of food waste you have to process.)
2. Lay bamboo poles (or similar) in a parallel row on the pit floor and cover with a lattice of wood strips to provide drainage (worms cannot survive in a waterlogged environment).
3. Line the pit with a suitable material to keep worms from escaping into the surrounding soil whilst allowing drainage of excess water (old animal food sacks, for example – not plastic).

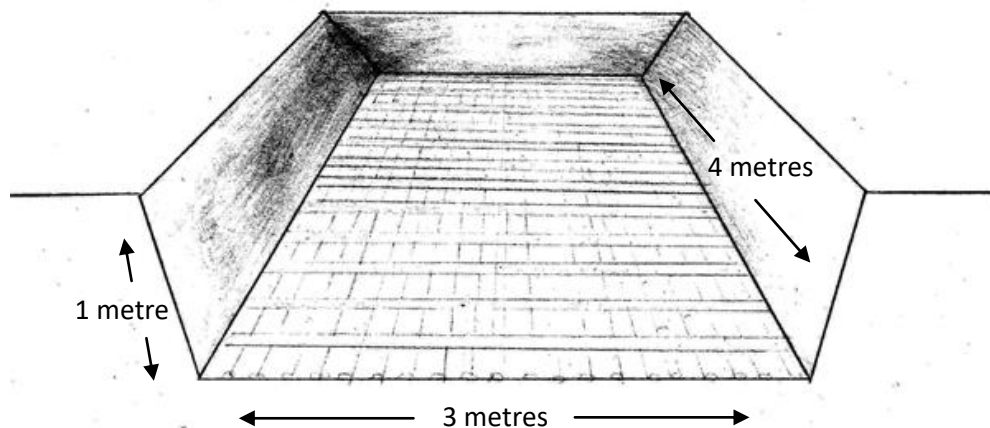

Figure 6-3: The pit method of worm composting.

Add the compost and worms to the pit:

4. Fill the pit with organic waste (food waste). Cover loosely with soil and keep moist for a week or so.
5. Apply a good amount of water to one or two spots on the heap and place the vermicomposting worms on top. They will burrow rapidly into the damp soil.
6. Leave the pit for 2 months, preferably shaded from hot sun and kept moist.



Figure 6-4: Apply worms to the compost pit (picture not to scale).

Digging out / re-filling the pit and harvesting the worms:

7. After 2 months, dig out 2/3 - 3/4 the contents of the pit and remove the bulk of the worms (by hand or sieving).
8. Refill the pit with fresh organic residues and the remaining worms will continue the composting process.
9. Sun-drying and sieving the compost improves the quality of the final product.
10. The excess worms that have been harvested as above can be used in other pits, sold to other farmers or used/sold for use as animal feed supplement or fish food.

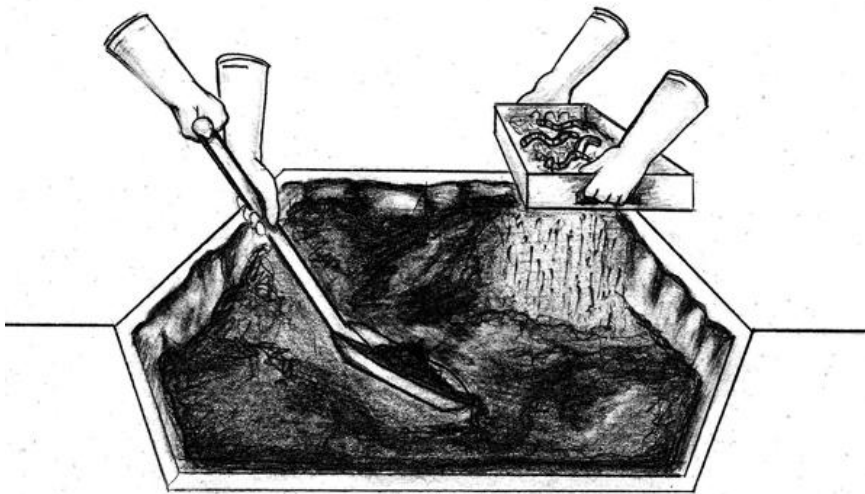

Figure 6-5: Digging out, re-filling and harvesting worms (picture not to scale).

## 7. How to prepare plastics to sell to market

*Sometimes it is more practical and profitable to collect and sell sorted plastics than to recycle them yourself.*

**Summary:** Collect, sort, clean and bulk different plastic materials in the right way. Learn how to identify common types of plastic.



***It is always better to work with clean, separated materials than with mixed waste.***

***Clean, sorted and bulked plastics are much more valuable.***

**Note:** The processes of sorting, cleaning and bulking materials to sell to merchants can also be applied to paper and card, metals and glass – provided there is a local market for these materials. The value of clean materials is calculated by weight. Since plastic does not weigh much it helps to do some additional processing to maximise the value of the material, for example gathering a large quantity, shredding, compacting, and baling.

**Quality:** Good quality materials are likely to fetch higher prices. Good quality materials are:

- Clean and dry, not covered in food waste or dirt or left out in the rain
- Very well sorted, with only the type of material that your buyer wants
- Compacted and baled to reduce transport costs

**Quantity:** Your buyers will want to know that you can provide a regular supply of quality material. If you have enough, they might send a vehicle.

**Storage:** It is important to have a place large enough to store collected material, keeping it dry, away from animals and safe from possible theft.



*When you are dealing with plastics:*

- *Only use the flame test as a last resort.*
- *Be very careful that you are clear on which type of plastic you are handling and that there are no other types mixed in. This is very important when doing the flame test.*
- ***NEVER BURN PVC – IT IS EXTREMELY TOXIC.***
- *Plastic waste may be dirty and could carry disease, especially if it was used for packaging food before and is stored where rats can touch it. Always wash your hands after dealing with waste plastic.*

## How to increase the value of your plastic

### 1. Cleaning

If plastic is clean it is more valuable. You can wash it before, during or after sorting (floating in water is also a good way to sort the plastics).

- Empty any contents of containers into prepared collection barrels
- Remove other materials and the wrong plastics – remove lids and paper, plastic or metal labels
- **Manual washing:** This can be done in large drums or containers. If the plastic is covered in oil, then use hot water with soap or caustic soda (use gloves if using caustic soda)
- **Mechanical washing:** Use a water filled container with a motor with paddles at low speed. The plastic is left to soak whilst the paddles stir continuously. The dirt settles out and the plastic is removed with a drainer.

### 2. Drying

Either leave in the sun or dry with a fan and gas burner.

### 3. Sorting

You need to do this to the requirements of your customers, but this is often the way that is needed:

- Remove all materials that are not plastic (such as paper labels or metallic stickers)
- Separate films (soft plastics) from hard plastics
- Separate the plastic types (PVC should always be separated, as a minimum)
- Separate films into transparent and mixed colour
- Separate rigid PE materials into light (transparent and white) and mixed colour.

### 4. Agglomeration

You might want to do this with film plastic so it takes up less space and makes it easier to handle and sell. An agglomerator consists of a vertical drum with a set of fast moving blades at the bottom, which chops the sheets into thin film flakes. Due to the cutting and friction energy of the process the flakes become warm, and start to melt and form crumbs or agglomerate (join together). This will increase the bulk density of the material so it can be fed directly into reprocessing machines.

## 5. Reducing the size of plastic

Making plastics denser helps reduce transport costs and can be more easily fed into reprocessing machines. There are different ways to do this:

- A. Cutting: You can cut materials, like gallon containers, into smaller pieces to make it easier to transport or feed into shredders (3 labourers, each with scissors, can cut up 1 tonne of sorted plastic per day).
- B. Shredding: This will cut plastics into small enough pieces to transport or reprocess. You can use a mechanical shredder (a small one with a 5kw motor could be used to start and grow as you save more money). If you have not already washed the plastics, you can now easily rinse with water or remove any dirt or dust.

*To build your own plastic processing machines see free blueprints online<sup>8</sup>.*

- C. Flaking: If you have a hammer mill you can produce plastic flakes, which are easier to handle in industrial processes.
- D. Baling: You can use handmade or bought machines, you can get up to 15 times more plastic in the same space if you bale.

Type of material	Loose weight of material	Baled weight of material
PET (soda bottles, food packaging etc.)	18-24 kg/m <sup>3</sup>	240-350 kg/m <sup>3</sup>
HDPE (milk jugs, detergent containers)	13-14 kg/m <sup>3</sup>	240-300 kg/m <sup>3</sup>

Figure 7-1: It is much more efficient to transport material that has been baled<sup>9</sup>.

<sup>8</sup> Blueprints are available from Precious Plastic: <https://preciousplastic.com>

<sup>9</sup> WASTE (2011) *Solid Waste Entrepreneurship Guide*.

## How to identify common types of plastic



*When you are dealing with plastics:*

- *Only use the flame test as a last resort*
- *Be very careful that you are clear on which type of plastic you are handling and that there are no other types mixed in. This is very important when doing the flame test.*
- **NEVER BURN PVC – IT IS EXTREMELY TOXIC.**
- *Plastic waste may be dirty and could carry disease, especially if it was used for food before and is stored where rats can touch it. Always wash your hands after dealing with waste plastic.*

If you work with plastics regularly you will soon find it easy to identify the most common types of plastic simply by their look and feel.

There are three other simple ways to identify different plastics.

### 1. See if you can find an identification number







Recycling Number	Abbreviation	Full name
	PETE or PET	Polyethylene terephthalate
	HDPE or PE-HD	High-density polyethylene
	PVC or V	Polyvinyl chloride
	LDPE or PE-LD	Low-density polyethylene
	PP	Polypropylene
	PS	Polystyrene
	OTHER or O	Other plastics, such as acrylic, nylon, polycarbonate, and polylactic acid (a bioplastic), and multilayer combinations of different plastics

Figure 7-2: Plastics can be identified by their recycling number.

## 2. Float test

Cut out a flat piece of the plastic, about the size of a coin and put it in fresh (not salt) water (it doesn't have to be clean water):

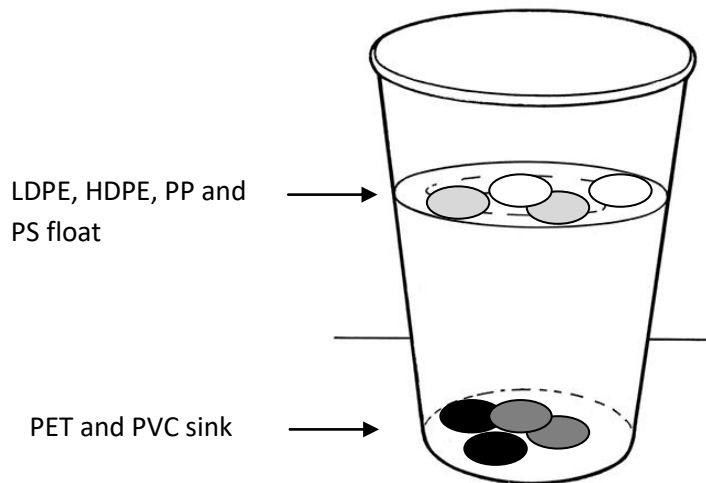

Figure 7-3: The float test can help you identify different types of plastic.

## 3. Flame test

Only do the flame test if you have tried everything else and are still unsure which plastic it is.

Take a small piece of your plastic, the size of a coin. Go outside to a well-ventilated area away from other plastics. Hold the plastic away from your body and light it using a long stick or match:

- Observe the colour of the flame. LDPE, HDPE and PP have a blue flame with a yellow tip; PET and PS have a yellow flame with dark smoke; PVC has a yellow flame with a green tip (avoid burning PVC if possible).
- See how easily it burns. HDPE and LDPE burn easily – be very careful if you are testing this type of plastic because it can melt and drip; PVC will light but not so easily and does not drip; PET also lights but not so easily and bubbles as it burns.
- Note the smell from the smoke. If you must, and this is strongly advised against, waft the smoke towards you and take a quick smell of the smoke to give you further clues as to the type of plastic

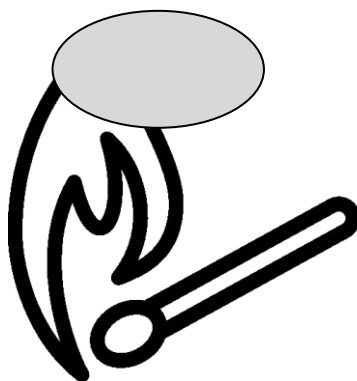

you are handling. **WARNING:** if you have already identified the plastic from other methods and particularly where you suspect the plastic is PVC, do not burn it.

- PET smells similar to burnt sugar
- LDPE and HDPE smell like candle wax
- PP has a sweet smell
- PS smells like gasoline
- PVC has an acrid smell like chlorine – if you accidentally burn PVC stay away from the smoke and gas it releases, and put out the fire immediately.

## 1 PET (Polyethylene Terephthalate)

Common uses for PET are:

- Water or soft drinks bottles
- Food trays and containers
- Hair product bottles.

PET is clear and tough and stops gases or liquids entering. It becomes softer at around 80°C. Lids and labels are made from other plastics.



### What can PET be recycled into?

PET plastic is crushed and then shredded into small flakes which are then reprocessed to make new PET bottles, or spun into polyester fibre. This recycled fibre is used to make textiles such as fleece garments, carpets, stuffing for pillows and life jackets, and similar products.

NOTE: PET is intended for single use applications; repeated use increases the risk of chemicals seeping into the liquid and bacterial growth. PET plastic is difficult to decontaminate, and proper cleaning requires harmful chemicals.

### How can I tell something is made of PET?

1. Look: PET containers are clear, sometimes have a “1” printed on them and are often used for water or drink bottles. They have a bump on the bottom of the bottle.



2. Float test: PET will sink in water.

3. Flame test:

- Yellow flame
- Plastic drips
- Burns slowly
- Smells like burnt sugar
- Light smoke with soot (floating particles).

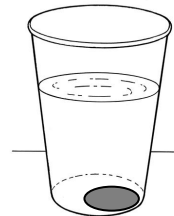



## 2 HDPE (High-Density Polyethylene)

Common uses for HDPE include:

- Detergent and oil bottles
- Toys
- Heavy-duty plastic bags
- 'Gallon' containers for holding fuel, oil etc.



### What can HDPE be recycled into?

HDPE is the most commonly recycled plastic and is considered one of the safest forms of plastic. It is a relatively simple and cost-effective process to recycle. It is very hard-wearing and does not break down under exposure to sunlight or extremes of heating or freezing. For this reason, HDPE is used to make picnic tables, plastic lumber, waste containers, water pipes, fence posts or other products which require durability and weather-resistance.

### How can I tell if something is made of HDPE?

1. Look: It often has a 2 printed on it. HDPE is hard, semi-flexible, and resistant to chemicals and moisture. It has a waxy surface, is opaque (you cannot see through it) and softens at 75°C. It has a ridge at the bottom of the container. 
2. Listen and feel: Many plastic shopping bags are manufactured from HDPE and the easiest way to distinguish them from LDPE bags is from the sound they make when you crinkle them in your hands. If the sound is soft and swishing (think of green leaves blowing in the trees), then you have identified LDPE; if the sound is crisper and crinkly (think of dry leaves being crushed together), then you have HDPE. The two sounds are quite distinct.
3. Float test: HDPE will float in water.
4. Flame test:
  - Blue, yellow tipped flame
  - Burns slowly
  - Plastic drips
  - Smells like candle wax (paraffin).

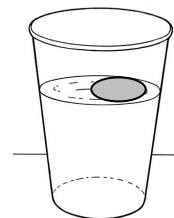

### 3 Polyvinyl Chloride (PVC)

PVC comes in two forms:

**Rigid:** (sometimes abbreviated as RPVC) and flexible. The rigid form of PVC is used in construction for pipe and in profile applications such as doors and windows. It is also used for bottles, other non-food packaging, and cards (such as bank or membership cards).



**Flexible:** Plumbing, electrical cable insulation, imitation leather, signage, music records, inflatable products, and many applications where it replaces rubber.

#### What can PVC be recycled into?

It is used for flooring, shoe soles, wellington (“rubber”) boots and shoes.

#### How can I tell if something is made of PVC?

1. Look: It often has a 3 printed on it.

- Rigid PVC is strong, tough, can be clear or opaque, and softens at 80°C.
- Flexible PVC is plasticised, clear, elastic and can be welded by solvents.



2. Float test: PVC will sink in water.

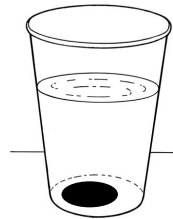

3. DO NOT perform the flame test.



*Stay safe: do not burn PVC.*

*It produces extremely toxic fumes.*

#### 4 Low Density Polyethylene (LDPE)

LDPE is used for plastic bags and film, waste bags, and bottles you can squeeze.

##### What can LDPE be recycled into?

LDPE can be recycled into building materials, as well as bags.

##### How can I tell if something is made of LDPE?

1. Look: LDPE is soft and flexible (it is usually used as a film). It is translucent (lets light through but is not clear), and softens at 70°C. It often has a 4 embossed on it.
2. Feel: LDPE feels soft, smooth and flexible. It can be scratched easily with a fingernail.
3. Listen: If you rub it together, it will make a soft swishing sound, as opposed to a crinkling, harsher sound.
4. Float test: LDPE floats in water.
5. Flame test:
  - Blue, yellow tipped flame
  - Burns slowly
  - Plastic drips
  - Smells like candle wax (paraffin).

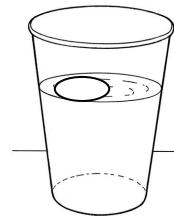

## 5 Polypropylene (PP)

PP comes in many forms and has many uses:

- Bottle caps
- Food containers
- Buckets
- Appliances
- Plastic chairs
- Crystal clear plastic bags used for retail and presentation (BOPP)
- Woven rice sacks and animal feed sacks
- Plastic shopping bags with a woven appearance
- Sports clothing
- Disposable sanitary napkin linings
- Rope.



### What can PP be recycled into?

PP is commonly recycled into tubes, rigid packaging, containers, crates, disposable cutlery, pallets, hangers, and tubs.

### How can I tell if something is made of PP?

1. Look: Rigid PP is usually hard, opaque and coloured using pigments. Woven PP looks like cloth and is used for sacks and bags. Specially treated, PP becomes crystal clear and is used in packaging and retail for presentation. It has a high melting point (160°C). PP often has a 5 stamped on it.



2. Feel: Woven PP feels soft, like cloth. Rigid PP feels rugged. It cannot be scratched with a fingernail.

3. Float test: PP floats in water.

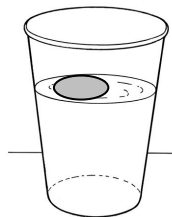

4. Flame test:

- Blue, yellow tipped flame
- PP shrinks quickly but burns slowly
- Plastic drips
- Has sweet odour.



## 6 Polystyrene (PS)

Common uses for PS are:

- Disposable plastic cutlery and dinnerware
- Food containers
- CD cases and cosmetic packs
- Disposable razors.

Expanded polystyrene (EPS) is used for:

- Insulation panels
- Packing “peanuts” and packaging
- Foam cups and food containers.



### What can PS be recycled into?

PS cannot be recycled easily. EPS is especially lightweight and so transport is often uneconomical. When it is recycled, it is melted and turned into pellets to be used in the production of toys, outdoor furniture and insulation.

### How can I tell if something is made of PS?

1. Look: PS is rigid and shiny. EPS is usually white and made of pre-expanded polystyrene beads. It often has the number 6 on the base.



2. Feel: EPS is rigid and tough, but crumbles into separate grains. (This is different to the kind of foam used in furniture and car seats, called Polyurethane foam.)

3. Float test: PS and EPS float in water.

4. Flame test (PS and EPS):

- Yellow flame
- Burns quickly
- Plastic drips
- Smells like gasoline
- Dense black smoke with soot (floating particles).

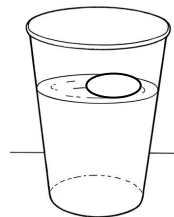

## 8. How to transform plastic waste into paving tiles

*You can convert waste plastic into useful and valuable building materials.*

**Summary:** Melt LDPE plastic film in a barrel over a wood fire. When the plastic has melted, mix in sand. Transfer the mixture to an oiled mould. Remove the mould and leave to cool.

**Waste materials:** Plastic bags, water bags, plastic film, containers – the correct type is Low Density Polyethylene (LDPE). See *How to identify common types of plastic*, How-to guide 7.1 to identify the correct plastic type.

**Product:** Paving slabs, sanitation slabs, floor gutters and bricks.

**Benefits:** You can make a variety of building materials that are cheaper than the concrete version. They set quickly and are very strong. Depending on the mould, you can make floor or paving tiles or even bricks for walls. They also make good rainwater harvesters: being non-water absorbent, the risk of dew, algae and fungus is almost eliminated, and this ensures clean water. You can add colourants such as iron to make red tiles. Bricks made with this technique make good insulation, keeping you warm in winter and cool in summer.

The sand in the tiles acts as a fire retardant. If there is a fire, the outer layer of plastic melts, leaving a face of sand. Sand is not flammable, so it slows the spread of the fire through the brick. Never light a fire directly on top of plastic floor tiles. Plastic tiles are not advisable for roofing in case of fire.



***Always make sure you have clean, separated material and you know what it is. If in doubt, leave it out!***

**Hint:** Use fine, dry sand. The best type is ‘sharp sand’ or ‘construction sand’ used for making concrete. Sieve the sand to remove small and large particles that can lead to pockets of air, or pores, in the finished tile.



*It is VERY IMPORTANT to only use the correct types of plastic and that you know what is in your mix. You should ensure there is **no PVC**. Fumes from other types of plastic can be very dangerous.*

*Always use a well-ventilated area.*

*You will be using heat and fire. Make sure you have fireproof gloves (fabric, NOT rubber), heatproof boots (NOT rubber), and cover your arms and legs with overalls or heavy trousers.*

**You will need:**

- Overalls, gloves, masks, covered shoes or boots
- 1 melting barrel (an oil drum cut in half, 80cm wide and 50cm high). If possible use a shield to keep the fire concentrated under the barrel
- Stirring equipment (a spade with a metal shaft, or metal reinforcing rods with a metal paddle welded to the end)
- Firewood or other solid fuel
- Clean, dry, sieved sharp sand
- Tile mould (no more than 4cm deep)
- Used engine oil
- Metal table
- Trowel.

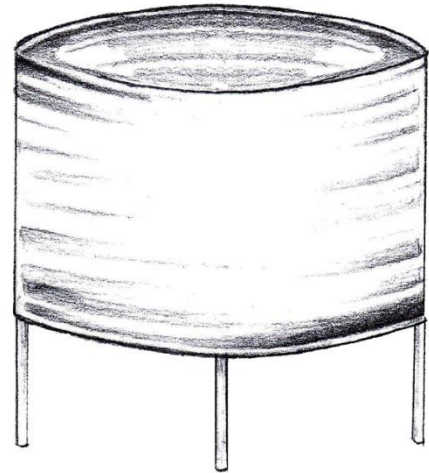

Figure 8-1: Prepare a melting barrel 50cm tall and with three rebar legs.

**How to make the melting barrel**

To make the melting barrel, cut a simple oil drum in half and attach three legs made of rebar. With the legs attached, the ideal height of the barrel is 50cm, and 80cm wide. Try to make the burner big enough that you can hold a good amount of liquid plastic but not so tall that it is tricky to mix. If you can sink the legs into the ground it will make the barrel more stable for mixing.

**How to make the mould**

The moulds can be whatever shape you wish – they are constructed in the same way as moulds for concrete floor tiles. If the walls of the mould are more than 4cm deep however, the material will stick to the sides and not come out properly.

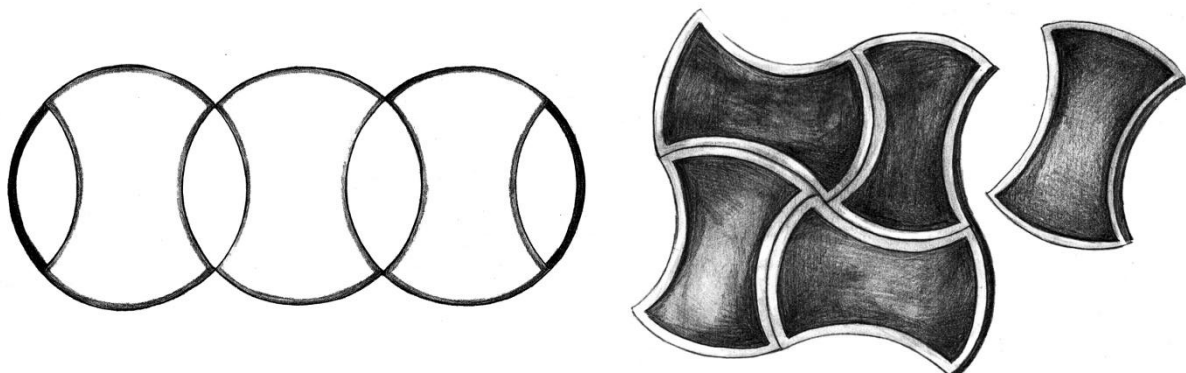

Figure 8-2: Example tile moulds. Tile moulds can be many different shapes, provided the tiles fit together with no gaps. This mould (left, above) produces 3 tiles with the shape illustrated on the right. It is made by cutting and welding three rings.

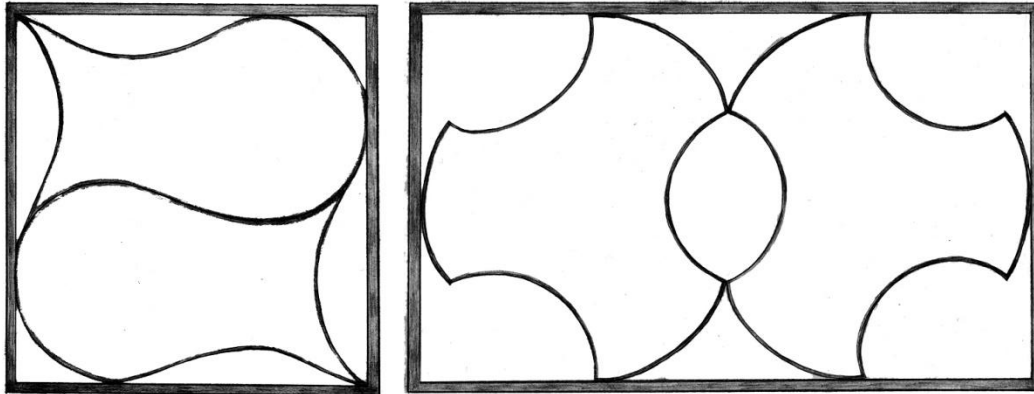

Figure 8-3: Alternative tile mould suggestions.

### How to know how much sand you will need

The strength of the floor tile depends on the mix with sand. Laboratory tests indicate that the optimum mixture is 3 parts sand to 1 part LDPE (3:1 sand:plastic), however it is strongly recommended that you try different mixes for yourself. Try starting with 50:50 sand:plastic and then increasing the proportion of sand to 60:40 and 70:30 to see what works best for you. A mix of 75:25 works well for floor paving tiles to be used in a home compound. Usually, the tiles contain more sand than plastic, because the plastic serves as a bonding agent to hold the sand together.

As a rough guide, one standard rice sack of plastic with around 200 plastic bags (weighing around 2.5 kg) makes one paving slab.

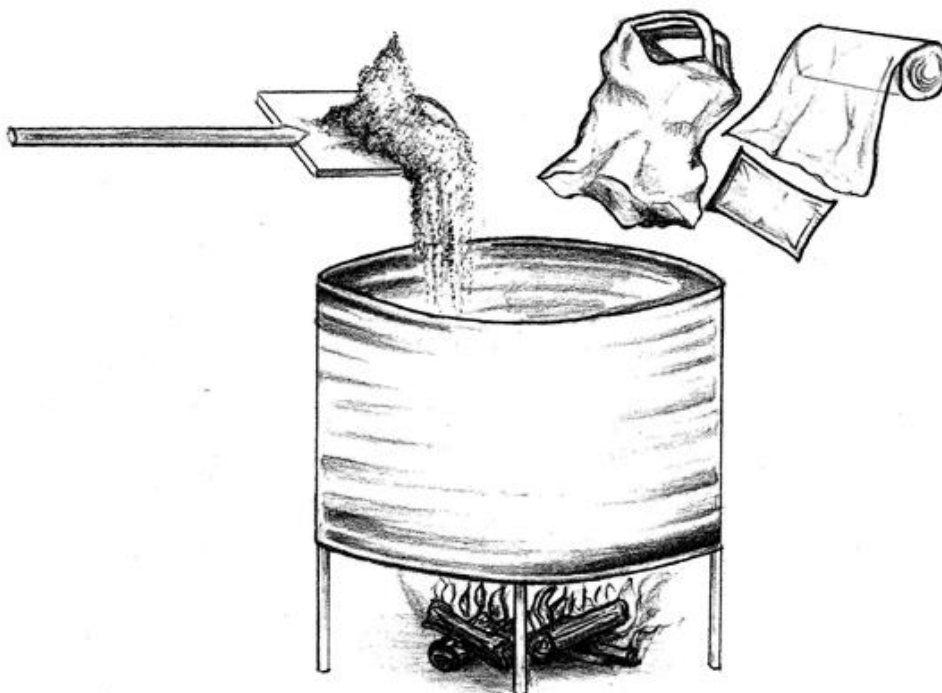

Figure 8-4: Experiment with different quantities of LDPE, HDPE and sand.



### 1. Select the right plastic

It is important to only select the correct type of plastic. This is because different types of plastic melt and burn at different temperatures and have different physical qualities. The process described here works well with LDPE<sup>10</sup>.

Water bags, non-woven plastic shopping bags and plastic film are usually made of LDPE. It is important that you do not use other types of plastic – it could be harmful to your health. How-to guide 7.1 discusses how to identify the different types of plastic.

Make sure your plastic waste is mainly clean. Remove all materials that are not LDPE (including other plastics). If you're not sure if something is LDPE, leave it out.

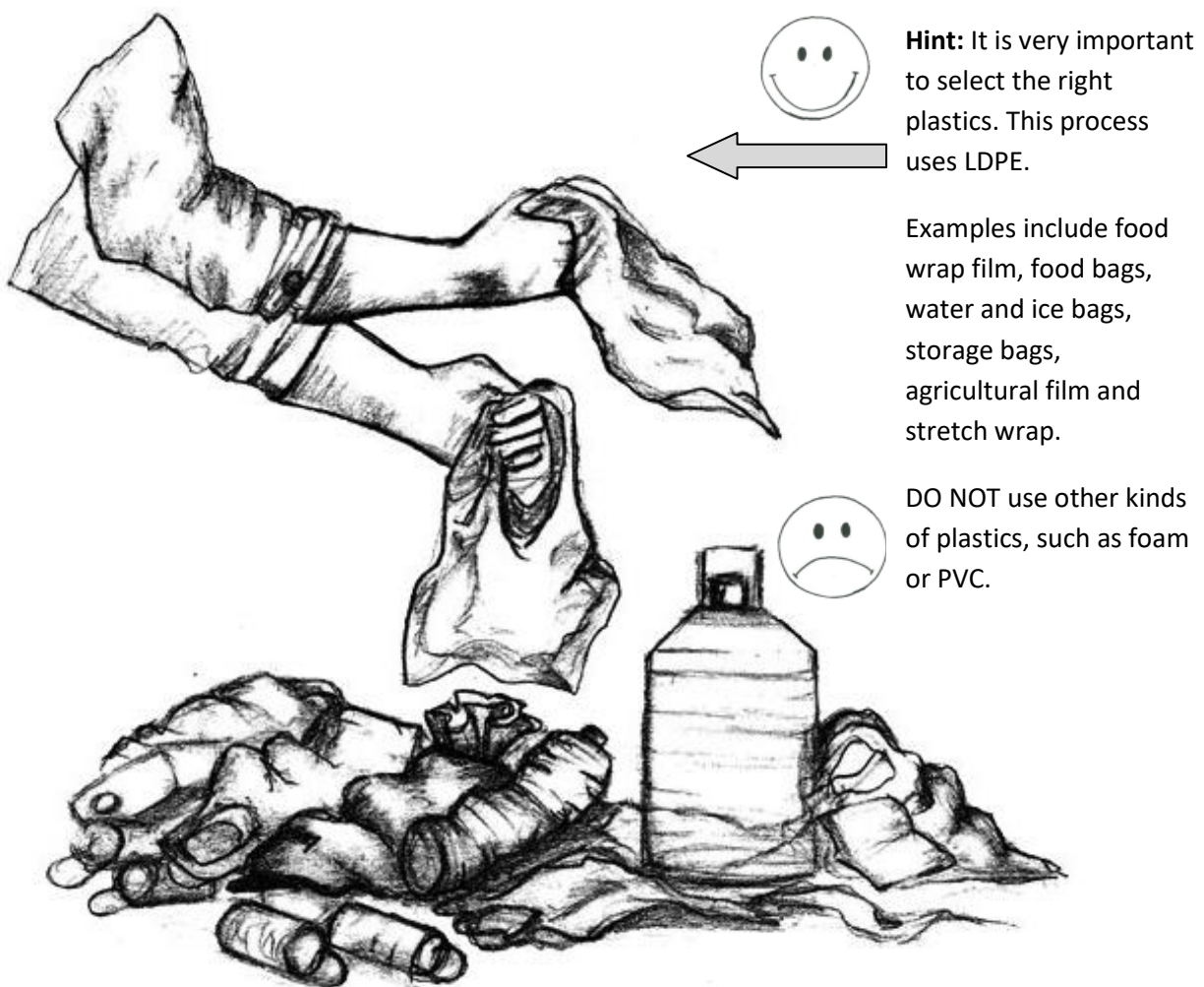

Figure 8-5: Sort your plastics carefully.

<sup>10</sup> Process design from the Living Earth Waste to Wealth programme; and Pierre Kamsouloum, entrepreneur, teacher and WasteAid Associate, Cameroon.



Figure 8-6: Keep mixing the melting plastic until it is a black liquid with no lumps.

## 2. Melt

Light a small fire under the metal drum and **gently** heat it. Add the plastic waste. As it warms up it will reduce in size. Light the plastic at the top using a small flame to help it melt down.

Make sure the fire does not get too hot. Keep adding plastic gently at the side of the melted plastic until it melts down to a black liquid. Keep adding plastic until you have around a 20cm depth of melted plastic.

Do not stand directly over the melting barrel; try to avoid breathing any gases from the fire; and take care as tools can get hot!

## 3. Mix

Keep mixing thoroughly until all the plastic has melted and there is a consistent black liquid. Sometimes LDPE lumps can remain even at very high temperatures. Stirring and heating must continue until all lumps are removed and a homogenous paste is obtained, since they affect the strength of the material. This can take up to 20 minutes. Do not let the liquid get so hot that it burns strongly – it will not work as a building material if this happens. A few flames from the

liquid is acceptable. Add sand until you have the required mixture and keep mixing so that the plastic, which acts as a binder, is very well mixed in and looks like grey cement.

## 4. Mould

Prepare the mould by making sure it is very clean, with no pieces of plastic on it from previous mouldings, and well oiled.

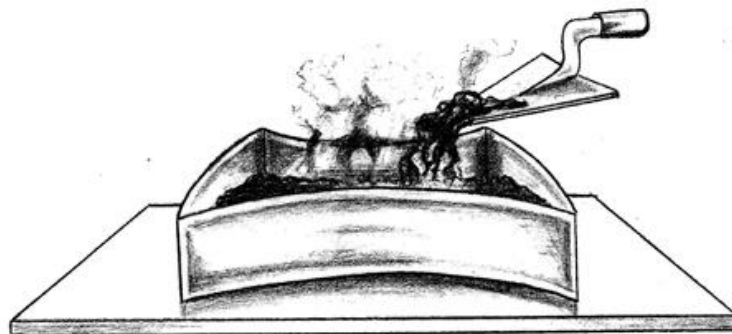

Figure 8-7: Make sure your tile moulds are clean and oiled before you start work.

Quickly remove the mixture using the spade with the metal shaft and put it into the mould with the trowel. The mixture is very hot so be careful and wear gloves.

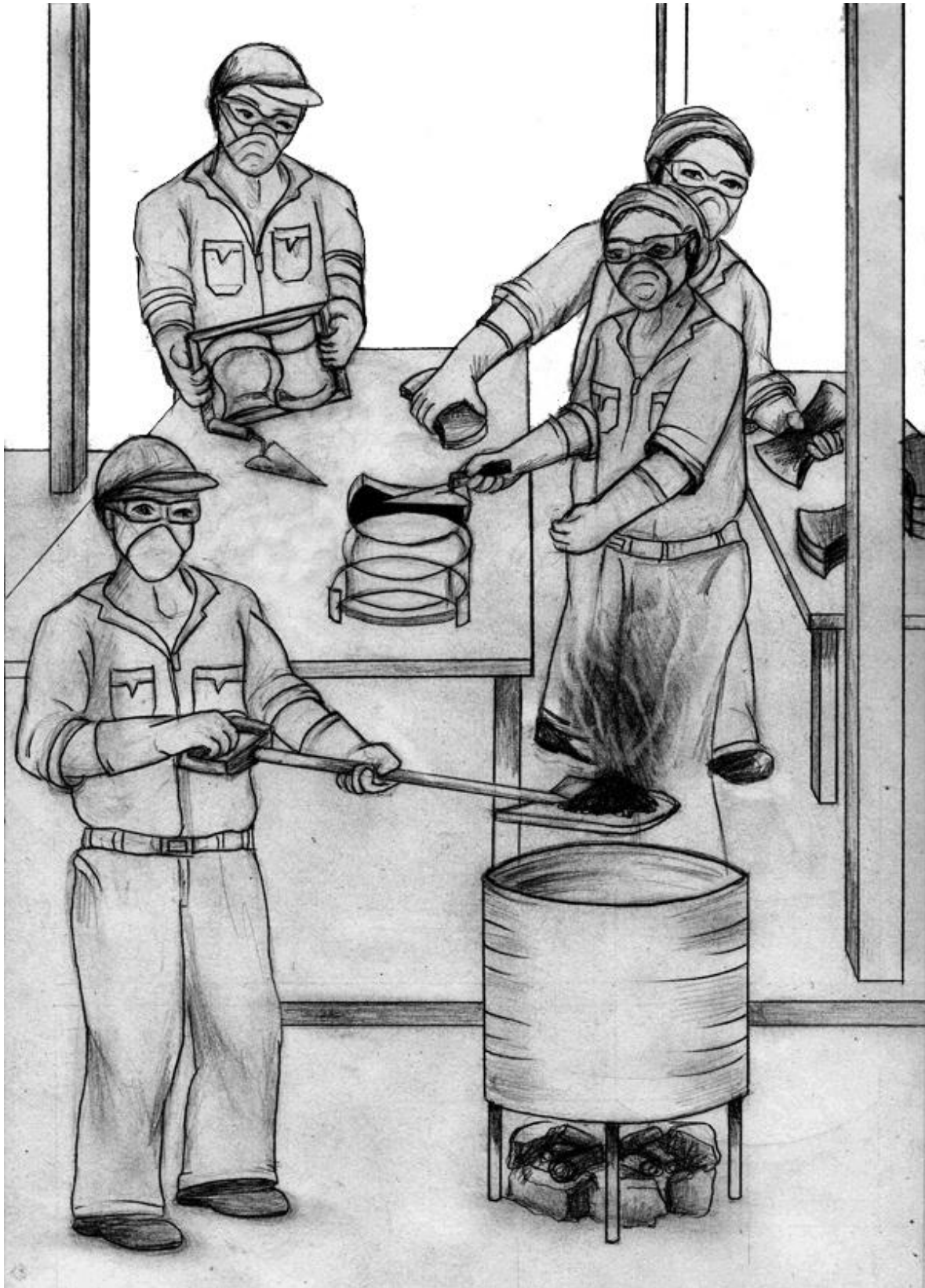

Figure 8-8: Take care when you transfer the mix from the barrel to the table.

Press and work the mixture into the mould so there are no air gaps.

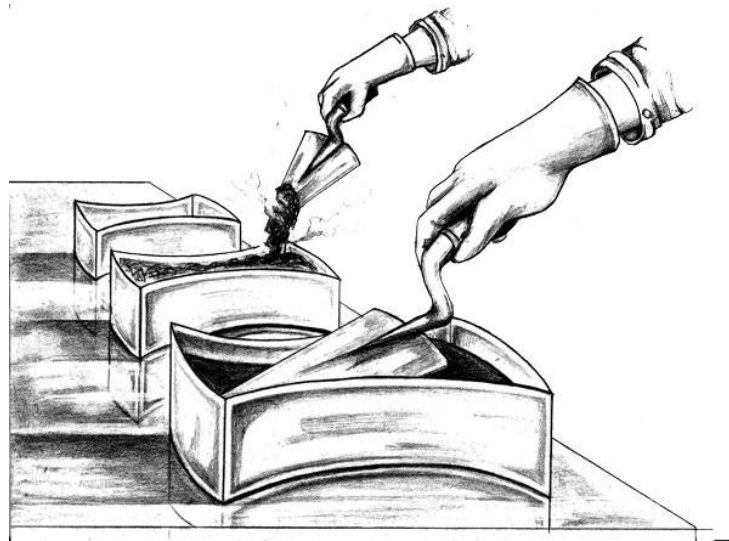

Figure 8-9: Press the mix tightly into the moulds. Air gaps will reduce the quality of your finished tile.

## 5. Set

Allow the hot mixture in the mould to set for a few minutes, repeatedly shaking the mould to loosen the edges (a rocking motion works well). Keep trying to lift the mould. When the mixture has hardened enough that the slab will not collapse, remove the mould and leave. It should harden in around 2 hours. Experiment with different amounts of sand and LDPE – the different amounts can be used for different purposes – slabs, tiles or bricks.



Figure 8-10: With practice you will be able to make a consistently high quality product.

## 6. Market

Tiles made in this way are as strong as concrete paving tiles. If you can have your product tested and certified as an approved construction product, you will be able to market it to local building companies as well as directly to customers.

## 9. How to turn mixed plastic waste and bottles into ecobricks

*Instead of cutting down trees or using concrete blocks, re-use plastic bottles to form the structure of your home. To make an ecobrick, stuff washed flexible plastics and polystyrene into a plastic bottle and replace the lid.*



**Summary:** Wash and dry flexible plastic waste and polystyrene, and stuff it tightly into a plastic bottle to make an ecobrick.

**Waste materials:** Any type of flexible plastic waste such as snack wrappers and plastic bags (washed and dried in the sun), Styrofoam (polystyrene), plastic bottles.

**Product:** Ecobricks.

**Benefits:** Some plastic wastes cannot be recycled easily, but they cause a lot of problems if they are dumped or burned. Ecobricks contain the plastic waste so they do not cause harm in the environment, and provide a free construction material that is highly insulating, lightweight and robust.

Everyone in the community can join in, including children. Thousands of homes and schools all around the world have been built using ecobricks.

**Hint:** Ecobricks can also be made from filling plastic bottles with earth.

Figure 9-1: Make an ecobrick by stuffing plastic waste inside a bottle.



*Any food residue on the plastics will produce methane which can be explosive. For this reason it is important to clean and dry the flexible plastics before stuffing them into the bottles.*

*Always wash your hands after handling any kind of waste.*

*Use gloves to protect your hands from any sharp edges.*

*If you are using ecobricks to construct a building, always work with a construction engineer.*

## Making an ecobrick

To make an ecobrick, wash and dry flexible plastic waste and stuff it tightly into a plastic bottle using a stick. Replace the lid. The ecobrick should be as solid as a brick. On average, 100 plastic food wrappers fit into a 600ml bottle.

Make hundreds or thousands of ecobricks. Use them vertically as the in-fill for timber-frame buildings, or horizontally, mortared together with clay or cement. To collect enough ecobricks to build with, you might like to involve many people in the community. This can take time, so be patient.

### Timber-framed ecobrick building *(adapted from BottleSchools.org)*

Firstly, check that you have suitable land, funding, community buy-in, masons and materials. Building with ecobricks is not very different from building with regular materials, using post and beam construction.

The key differences are:

1. A lot of plastic bottles and plastic filler waste need to be collected to make enough ecobricks, which will be used in place of standard building blocks or bricks.
2. You need to insert pins (short pieces of rebar) into the columns and beams before the concrete sets. You can then attach the chicken wire to the pins.
3. Tie ecobricks to the chicken wire, row by row, and then stretch another layer of chicken wire over the other side of the ecobricks.
4. Adding a cement finish means you can't even see the bottles. You might want to leave an "honesty window" to show people it really is made of plastic bottles!

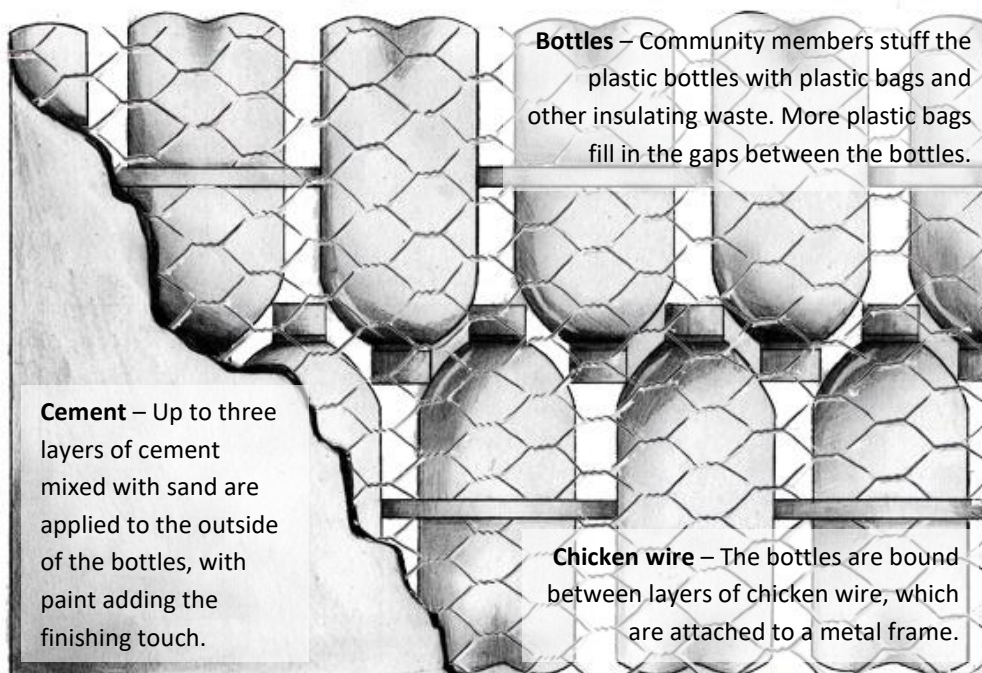

Figure 9-2: Timber-framed ecobrick building.

To make the bottle walls, stretch a length of chicken wire tightly between two columns, and attach it securely to the pins on the frame of the building.

Then, tie upright ecobricks to the chicken wire in rows, making sure to keep the bottles tightly secured to the chicken wire. Stand the bottles facing up for the first row, then facing down for the second row, fitting the lids in between the gaps as in Figure 9-2. Once all the bottles are in the wall, stretch another layer of chicken wire over the other side of the bottles, sandwiching the bottles in between the chicken wire. Fill any gaps between the bottles with more plastic waste.

Finally, apply three layers of cement (about 2.5cm in total) on both sides of the bottle walls. Make the final layer a smoother layer to present an attractive finish, and paint it.



*Make sure that you have strong concrete and rebar foundations – check with a structural engineer that they are suitable for your soil type and other conditions.*



***Glass bottles can also be used in construction, using the mortared (cob) method. Glass bottles are stronger than plastic bottles so do not need to be filled. Different colour glass bottles create an attractive light inside a building.***

#### **Mortared (cob) ecobrick building** *(adapted from Ecobricks.org)*

1. **Soil test:** Test the earth that you will use for your construction. Choose an earth with high clay content that sticks together when you squeeze it. Every clay/earth is different so you will need to experiment to find the best combination of sand and clay to use for the rest of your construction.
2. **Setting a safe work space:** Clear the space where you will be working of all hazards. Make sure there is plenty of free space to work and move.
3. **Laying the draft foundation:** Lay out your ecobricks on the ground to sculpt the footprint of your construction. This will help you determine the curves and shape as well as how many ecobricks you will need.
4. **Digging out the foundation:** Remove your draft ecobricks from the footprint you have marked out. In their place dig a trench 10 cm deep. Fill this with medium sized stones.
5. **Cementing the foundation:** Mix a rough cement mixture at 1 part cement: 10 parts sand/gravel. If you do not have sand or gravel you can use broken and crushed glass in place of the gravel. Pour the mix over top of the stones. Allow for 5 centimetres of cement above the rock tops.
6. **Laying the bottles:** Lay the ecobricks (those you used for your draft foundation) into the concrete. Ensure that only a maximum of 75% of the bottle is covered. Let the cement dry.

7. **Making the cob mix:** Mix your cob to the ratio that you discovered was best in Step 1. Use buckets to measure each part. Dump the buckets of sand and clay onto a large tarp. Add your organic binder (straw, hay, coconut fibre, etc...). Use your feet to mash and mix the cob. Add small quantities of water as you go to help the mixing (but not too much or your mix will be too soupy).
8. **Making the balls:** You will know that the mixture is complete when you can no longer see any sand and the entire batch is of the same consistency. Have your team make balls out of the mix– this is the last step in the mixing and compaction of the batch.
9. **Laying the bottles:** Bring the balls over to the construction. Bang them down onto the concrete layer. Cover with a layer of compacted cob approximately 5cm high. Then, lay your next row of bottles. Lay each bottle in between the two below it.

10. **Applying more cob:** Once the bottles are snug in the lower cob layer, fill in any large gaps between bottles (for example, on curves) with stones. This will help your cob mixture go further. Fill in with cob between the bottles. Add another layer of 5cm on top of the bottles.

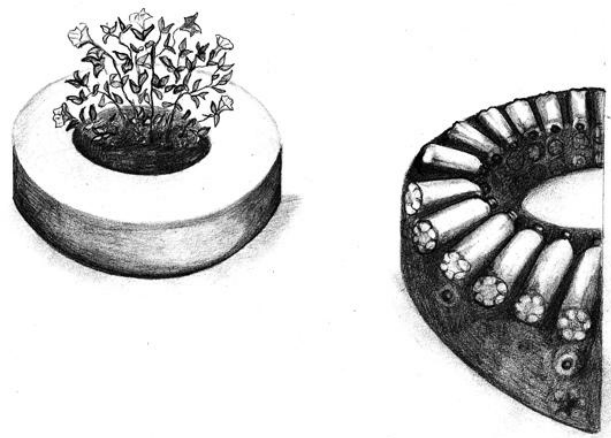

Figure 9-3: Curved walls can withstand strong winds.

11. **Building up:** Keep adding layers of bottles and cob! To make a bench you will need two or three layers of ecobricks. For walls, it is advisable to add a row of iron bar at every 5th layer of bottles.
12. **The outer skin:** There are many ways to render or cover your cob mixture to make it strong and water resilient.
  - Add cement to your cob ratio so that it is 20% of the mix. Mix in the same way as before. Apply to the outer layer.
  - Paint on a clear acrylic water proofing paint.
  - Paint on a layer of fresh cow dung combined with 10% fine clay.
  - Paint on a layer of lime render.
13. **Finishing the top:** For benches you will want to add a layer of cement for sitting upon. Mix cement at 1 part: 6 part sand. Apply at a minimum thickness of 10 cm.
14. **Finishing with broken tiles:** Use broken tiles to make a pattern on your bench top. Lay tiles out on a long board first in the desired pattern. Have the pattern ready when laying the cement for the bench top. While the cement is still wet, press the broken tiles half way into cement. Once semi-dry, use a trowel to cover with a layer of fine cement (1:4 mix). Use a wet sponge to continually wipe clean.



## 10. How to crochet film plastic into bags and mats

*You can make long-lasting reusable plastic bags, baskets and mats from strips of water sachets, single-use plastic bags and other film plastic.*

**Summary:** Wash and dry the plastic, cut into long thin strips and crochet into a variety of products.

**Waste materials:** Water sachets, plastic bags, plastic film wrap. Try and find materials that are clean and dry.

**Product:** Bags, baskets and mats.

**Benefits:** The products are easy and cheap to make. The plastic material is often freely available and you can make quite high value products with it. This also finds a use for the plastic rather than dumping and burning.

### DO:

- Try and find a reliable and clean source of plastic. See if you can get the producers to bring the plastic to you so you don't have to pay transport costs.
- Try out lots of different products to find out what sells well. Visit different markets and see what people want and what you can sell.

### DON'T:

- Make too much of a product without being confident it will sell.
- Use dirty plastic.



*Make sure you clean the plastic before you work with it and wash your hands after handling dirty plastic.*

*Be careful if you are picking the plastic from a waste dump – there could be sharp objects hidden among the waste.*

### You will need:

- Water and soap to wash the plastic
- Large sharp scissors to cut the plastic
- Crochet needle.

You might also like to make a pattern using:

- Textile or weaving straw
- Different colour plastic.

You can use different types of plastic film, such as shopping bags, wrapping film and water sachets. If they are not already clean, wash and dry them.

The best bags for this are thin plastic; thicker plastic is more difficult to work with.

You need to transform the plastic bag into a long, thin strip that you can crochet. To avoid needing lots of joins between short strips, follow these steps to cut the bag into one long ribbon.

1. Wash and dry the plastic bag.

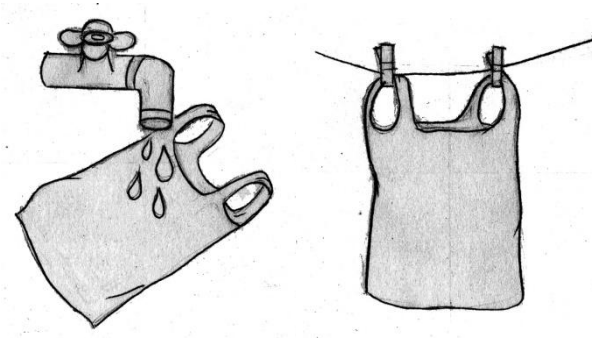

Figure 10-1: It is important to only work with clean plastic.

2. Lay the plastic bag out flat on a table and roll it neatly so the top and bottom of the bag are at the top and bottom of the roll. Then cut off the top (where the handle usually is) and the bottom seam to make a wide tube.

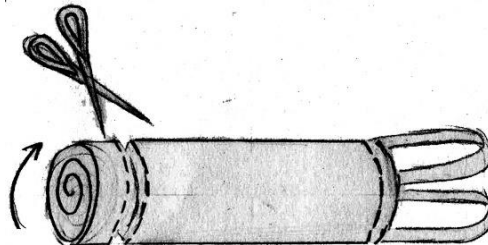

Figure 10-2: Cut the top and bottom from the bag. Save the off-cuts for other projects, such as stuffing small toys or ecobricks (How-to guide 9).

3. Open it out and check all the seams have been cut correctly. Then roll the bag again, but this time leaving an extra lip along one edge.

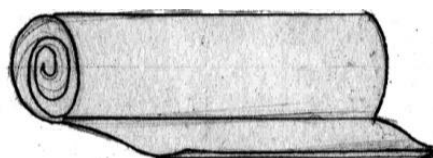

Figure 10-3: Roll the bag, leaving a lip on one edge.

- Place your thumb at the side of the roll and using sharp scissors, cut the folded part of the bag into a strip as wide as from the tip of your thumb to the first knuckle. Stop cutting when the scissors reach the edge of the roll and the start of the lip. Repeat all the way along the bag, making sure each cut is as wide as from the tip of your thumb to the knuckle.

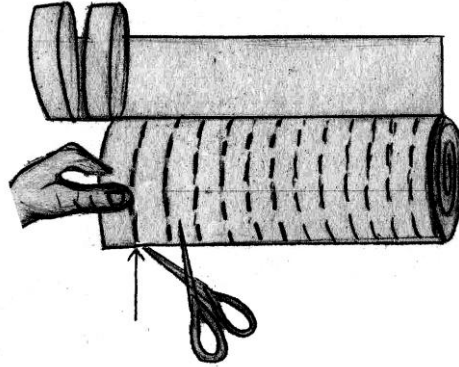

Figure 10-4: Leaving the lip intact, cut thumb-width strips all the way along.

- Then unfold the bag. Lie the bag on the table so the lip section is unfolded, and at the top.



Figure 10-5: Unfold the bag and lie it on the table with the lip section at the top.

- Starting at one end of the lip, cut diagonally from the first strip off to the side, to create an end to the plastic ribbon.

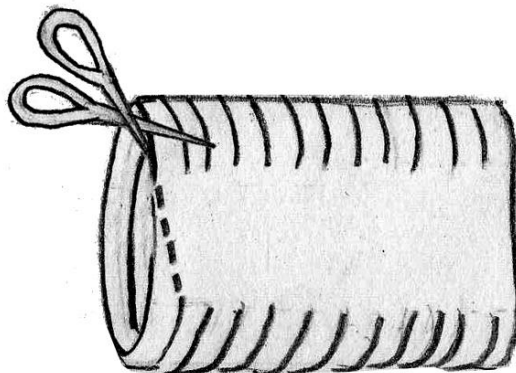

Figure 10-6: Make a snip from the top of one loop to the side of the lip. This will create an end to the ribbon.

- Then holding the plastic bag in your left hand, cut diagonally across to the next loop. You should start to see a long ribbon appear. Keep going until you reach the end, then cut diagonally to the edge of the plastic to finish the ribbon.

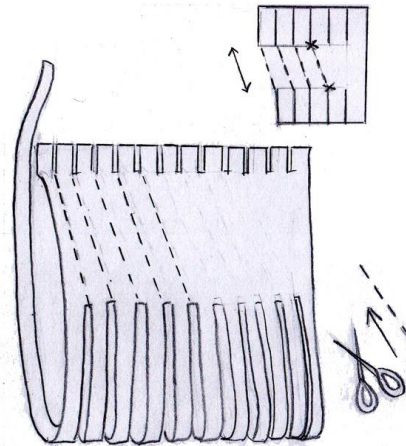

Figure 10-7: After the final loop has been cut, snip to the edge of the lip to finish the ribbon.

- Roll the long ribbon around your hand and tuck in one end, so you have a ball with a loose end to work with.

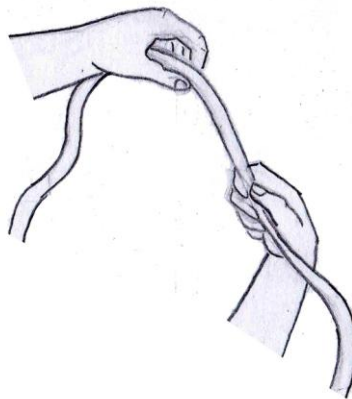

Figure 10-8: Roll the long ribbon like a ball of wool, with one end tucked in and the other loose.

- Now you are ready to crochet. The plastic yarn is best crocheted with a size K crochet hook (or larger). You can crochet shopping bags, purses, baskets and mats. Your creations are limited only by your imagination!

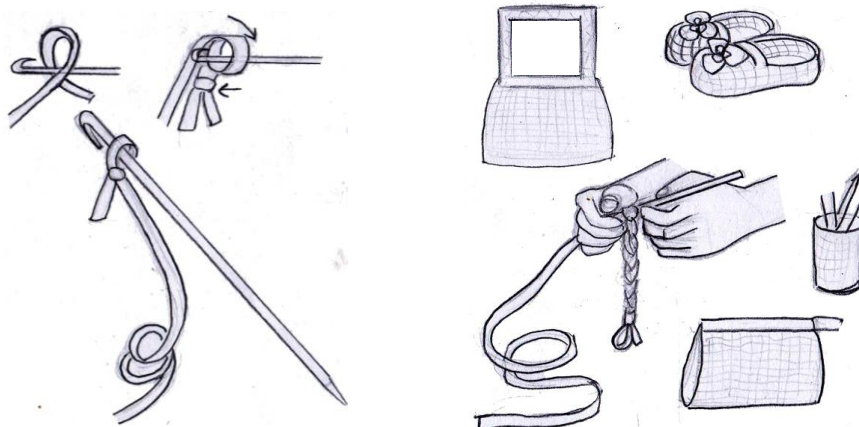

Figure 10-9: Crochet (or weave) a range of products using the plastic yarn. Create stripes and other patterns using different coloured plastic.

## Market

Work out what sells best – make samples and see whether larger bags, smaller phone covers or purses or wallets sell better.

EXAMPLE: In The Gambia, 1 laptop bag can sell for D800 (around USD\$12) and takes one week to make.

There are detailed instructions for this technique on YouTube: *“How to Recycle Plastic Bags into Purses: Isatou Ceesay - Njau, Gambia.”*



Figure 10-10: Working as a cooperative, you can make and sell many different products from waste.

## 11. How to collect waste safely and efficiently

*Collecting waste keeps neighbourhoods clean and reduces health risks, particularly for children.*

**Summary:** Collecting waste means gathering it from where it is produced (such as a home, business or market) and transporting it, either to an intermediate collection site or to a final place of recycling or disposal.

**Waste materials:** All – but think about how different waste types will require different types of collection. For instance, food waste may leak and attract flies, so will need containing and covering, where some bulky wastes, like cartons, may need to be transported in a larger container.

**Benefits:** Containing waste properly and transporting it safely and frequently enough means that it is less likely to attract animals and insects, smell bad, and spread disease. It is important to collect waste properly and efficiently, and to leave the area clean afterwards.



***Think about any materials you want to keep separate so they are easier to recycle.***

***Always try to improve the collection so it takes less time and effort.***

***Clean up after you have collected the waste.***



*Collect the waste in suitable containers and often enough so it does not become a nuisance or a danger to people.*

*Use containers with lids and handles, and make sure they do not leak.*

*Take care: sharp objects can puncture waste sacks. Lift heavy objects carefully.*

*Waste collectors must wear protective clothing – gloves, covered feet, arms and legs, and highly visible colours to avoid traffic injuries.*

*Always wash thoroughly after working with waste, especially before preparing or eating food or smoking.*

## Types of waste collection

There are three types of waste collection<sup>11</sup>.

### 1. Household

Household members collect their own solid waste in containers and carry it to a composting, recycling or disposal site or secondary storage.

This is suitable for collection of small amounts of waste and local (neighbourhood) processing or waste disposal.

The most suitable method is either to hand-carry or to use a small cart or wheelbarrow.

### 2. Neighbourhood

A representative of several households collects their waste and takes it to a composting, recycling or disposal site.

This is suitable for the collection of larger amounts of waste, and will require an animal and cart, a larger hand cart or a motor vehicle.

It requires strong community co-operation.

### 3. Community

Householders and businesses put waste out for collection, and paid workers collect the containers and take them to a community composting, recycling or disposal site.

There might be door-to-door collections, or communal containers placed near the road, marketplace or other public area.

This method requires co-operation from householders and businesses, requires collection of charges and payment of salaries to workers, and requires either an animal and cart or a motor-collection vehicle.

Figure 11-1: The three types of waste collection.

<sup>11</sup> The advice and diagrams in this How-to guide are based on USAID (1982) *Water for the World*, pp 385 – 464. We recommend consulting this document for more detail. It is available freely online at [http://pdf.usaid.gov/pdf\\_docs/PNAAL484.pdf](http://pdf.usaid.gov/pdf_docs/PNAAL484.pdf)

**Containers**

Waste containers are useful for temporarily holding solid waste before it is collected for disposal.

The type of container and its size may vary depending on availability and local preference. Containers used for community and paid-worker collection systems should hold 50-200 litres and must be sturdy enough to stand up to rough handling. Modern plastic containers with lids are often the most appropriate and easiest to obtain.

The number of containers needed depends on the amount of waste and the frequency of collection. There should be more than enough containers to hold all the waste generated between collection days.

Be aware that metal waste containers can be seen as valuable objects and might get stolen. If there is a risk of theft, either use containers made from very low value materials (such as recycled plastic or bicycle tyres), or alternatively keep them in a compound or locked to something secure.

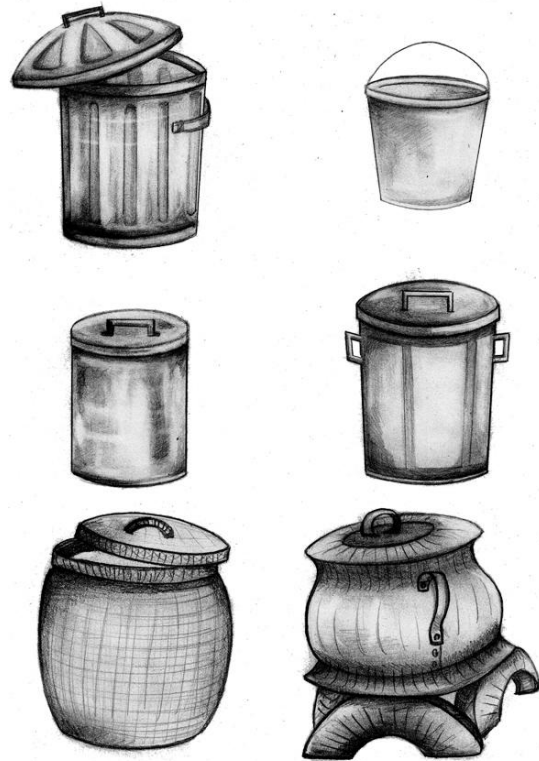

Figure 11-2: Different types of waste

**Cleaning equipment**

After collecting waste from a home or a public collection site, it is good practice to clean the area of any residue.

The type of equipment depends on the area to be cleaned, the nature of the waste, and personal preference. For household and community systems, individuals must provide their own equipment. For paid worker systems, the equipment should be provided by the community.

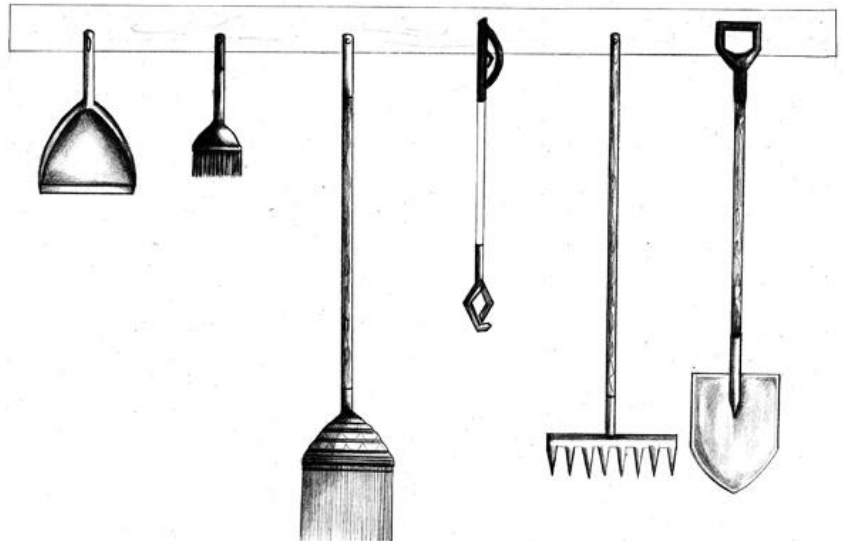

Figure 11-3: A range of useful cleaning equipment.

As shown in Figure 11-3, brooms and dustpans can be used to clean out houses, porches, pavements, or streets. Litter pickers are useful for picking up small pieces of waste. Shovels can be used to remove animal manure from the yard. Rakes, pitchforks, and shovels can be used to pick up harvest wastes or scraps from fields or factories. Short handled rakes are also useful to clean corners of footpaths.



## Transporting waste

There are many ways to transport waste, depending on the amount and type of materials, and the distance to the processing or disposal site.

Figure 11-4 shows a range of options. You can collect waste simply by hand in sacks (a) or tied with string, or use a wheelbarrow or handcart (b) or bicycle trailer<sup>12</sup> (c). To transport large amounts of materials you will need an animal-drawn cart (d) or motorised vehicle (e), and these will add to your costs considerably.

The loading height of a vehicle should be no more than 1m for ease of handling. Vehicle repair and replacement parts must be readily available, especially for paid-worker collection systems.

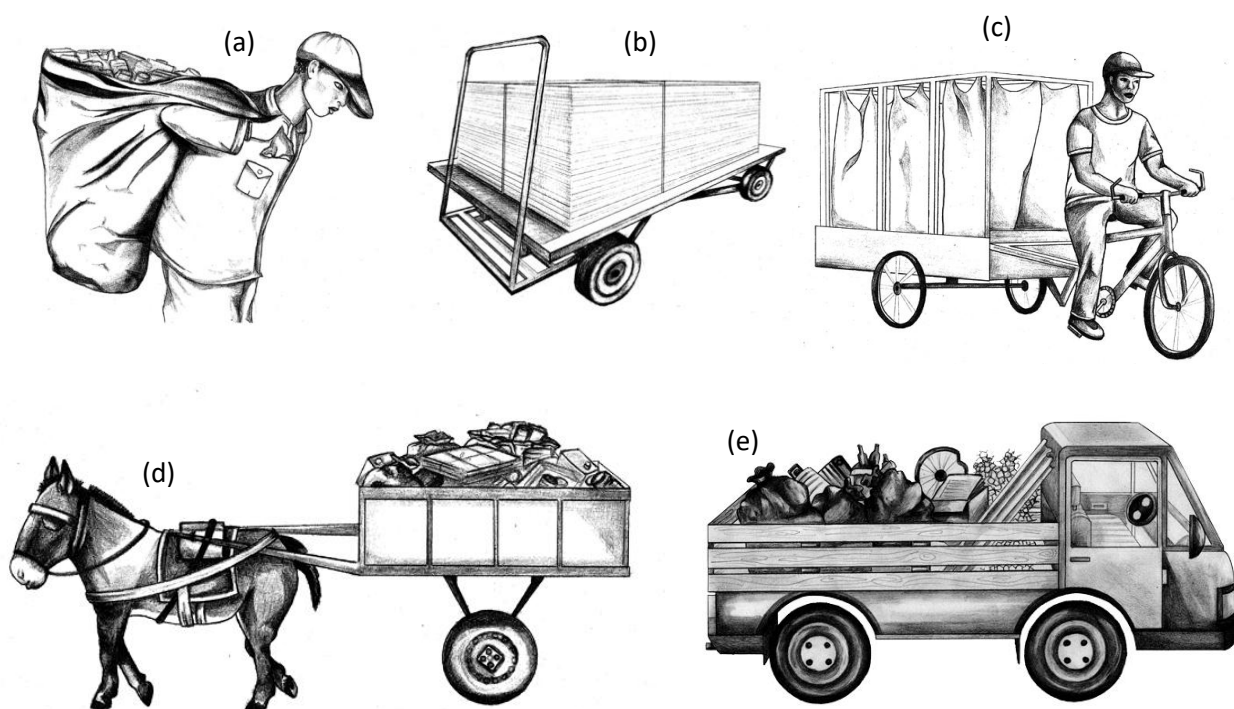

Figure 11-4: There are many different ways to collect waste.

## Frequency of collection

Solid waste should be collected often enough to easily handle the amounts being produced. This could mean collecting daily or two or three times a week. Collections of organic waste need to be at least once per week, because it takes just over a week for fly eggs to mature.

A daily market needs a daily waste collection. For other areas, two collections per week is usually enough. It is helpful to consider the following factors:

- Climate: In warmer, wetter climates organic waste will decompose (rot) more quickly, creating odour and attracting insects and other pests.

<sup>12</sup> This tricycle was designed by Wecyclers, which offers a recycling collection service to densely populated low-income neighbourhoods in Lagos, Nigeria.

- Separate collections: It is a good idea to collect food and woody waste frequently to avoid attracting flies and vermin. Dry materials such as paper and plastics can be stored and collected less frequently.

**Placement of waste containers**

Containers for collecting waste directly from homes, businesses and markets should be easily accessible to the collection team. If waste containers are transported to the disposal site, it is important to provide replacements or return the containers afterwards.

It may be that a container is filled in one location and collected from another. For example, a container may be placed near a market stall and filled with waste during the morning, then carried to the side of the road for collection by a paid worker in the afternoon.

**Collection routes**

Establishing a collection route is important to save time and effort and to make sure the system runs efficiently. An established collection route encourages a routine of cleanliness in the community. Plan the route so that it is as short and simple as possible and ends as near as practical to the disposal site<sup>13</sup>.

When the schedule has been agreed, draw up a map and mark your route.

To help establish a waste collection routine in the neighbourhood, it can be helpful to keep a record of participants, give timeslots to stallholders or householders, ring a bell when the collector is present, agree places to collect, and provide the collectors with a reward incentive.

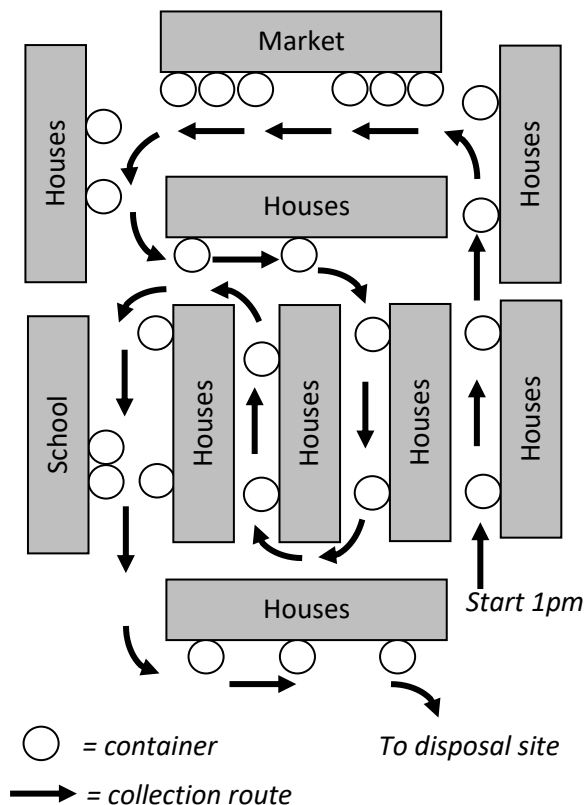

Figure 11-5: Example of a waste collection schedule.

<sup>13</sup> For further reading, see the UN-Habitat Guide, *Collection of Municipal Solid Waste in Developing Countries*, available online.

## 12. How to design and operate a basic waste disposal site

*After reducing waste, recycling materials and recovering value, there will nearly always be some waste left. This remaining waste might include sanitary napkins, oily rags, some textiles and various other items. These need to be collected regularly and buried safely, preferably in a planned and managed landfill.*

**Summary:** A waste disposal (landfill) site provides a safe place for unavoidable waste to be buried.

**Waste materials:** Only dispose of waste materials that cannot be reused or recycled.

**Benefits:** Safe waste disposal helps keep the air, water and land free of pollution, and helps prevent the spread of disease. Everyone should have their waste disposed of in a safe and well-managed waste disposal site, regardless of the size of their community.



### ***Always follow the 3C's of safe waste disposal: Control – Contain – Cover***

- **Control** – the community needs to agree on a single, suitable place to dispose of waste, and to stop burning and open dumping in communal areas and on common land. This means you need to organise as a community and agree rules.
- **Contain** – the disposal site should be used in an organised way, only using one area at a time. Agree which part of the site this is and ensure that there is good access to this area. Once one area is filled, cover it and move onto the next.
- **Cover** – waste in the site should always be covered with earth at the end of each day to control odour, prevent it blowing away with the wind, and ensure it is not eaten by livestock or vermin, nor used by flies and mosquitoes to breed in.



*Be prepared! You never know what is in the waste.*

*Always wear strong covered footwear, good gloves and covered arms when working at or near a waste disposal site.*

*Make sure there is good access to the site for people delivering waste.*

*Make sure there are no fires at the site.*

## What is a landfill?

The type of burial site used for unavoidable and non-recyclable waste is called a landfill, and is often a natural depression, or manmade trench or pit<sup>14</sup>. Waste is transported to the landfill site, where it is placed in a maximum of 1 to 2 metre high piles, compacted and covered daily in soil. The soil keeps away rats, flies and mosquitoes, prevents children from playing in the waste, prevents livestock from eating it, and eliminates odours and unsightliness.

If possible, it is better to place the waste on a level surface. If the site is on a slope then it is better to deposit the waste and push it up-slope (not down-slope). Deposit the waste each day in as small an area as possible so it is easier to contain and cover.

## Locating a landfill

The site for a landfill should meet the following requirements:

1. **Size:** The required size of a landfill site is determined by how much waste will require disposal over at least the next 5 years. To calculate this, multiply the daily waste generation (in litres) by 365 days, multiply that by five (or more) years, and then divide by two (because the waste will be compacted and will shrink as it dries out). Finally, divide that answer by 1000 to convert from litres into cubic metres.

*Example:* A community marketplace disposes of approximately 400 litres of waste each day. Therefore the amount disposed of in 5 years = (400 litres x 365 days per year x 5 years x 0.5 (compaction rate)) / 1000 litres per metre<sup>3</sup> = 365 metre<sup>3</sup>, so a landfill must be designed with at least this much capacity.

2. **Distance:** A landfill must be far enough from wells and streams to protect water supplies from contamination, far enough from dwellings to prevent causing a nuisance, and close enough to the source of the waste to avoid excessive transport. If you are making a landfill site for one house or compound, it should be at least 30 metres, preferably downhill, from wells and streams. A community landfill should be at least 200 metres, preferably downhill, from wells and streams and at least 200 metres from the nearest dwelling (see Figure 12-1).
3. **Geography:** A landfill should not be located on valuable land such as crop land. It should not be located on creviced rock because of the danger of groundwater contamination, or on marshy or wet ground because of the probable production of foul odours. Try to locate the landfill downwind from dwellings. It should be near a road for easy access.
4. **Groundwater:** The bottom of the landfill must be at least 1 metre above the highest groundwater levels. Information on groundwater levels may be available from residents, water well owners, or water well drillers. If not, a test hole 1 metre deeper than the bottom of the proposed landfill must be dug during the wettest season. If no groundwater is observed in the hole, the site is suitable.

---

<sup>14</sup> The advice and diagrams in this How-to guide are based on *Water for the World* (USAID, 1982), pp 385 – 464. Although it was published many years ago, the information is still valid. We recommend consulting this document for more detail. It is available freely online at [http://pdf.usaid.gov/pdf\\_docs/PNAA484.pdf](http://pdf.usaid.gov/pdf_docs/PNAA484.pdf)

- Cover soil:** The landfill must be located on or near ground which is easily excavated in order to provide adequate cover material. Loamy soils, sandy loams, and permeable clay mixtures are good. Heavy, non-permeable clays are hard to work and crack when dry surfaces are exposed.

When a suitable site has been located, draw a map showing the site in relation to dwellings, water wells, streams, roads, and so on, and indicating ground slope and prevailing wind direction.

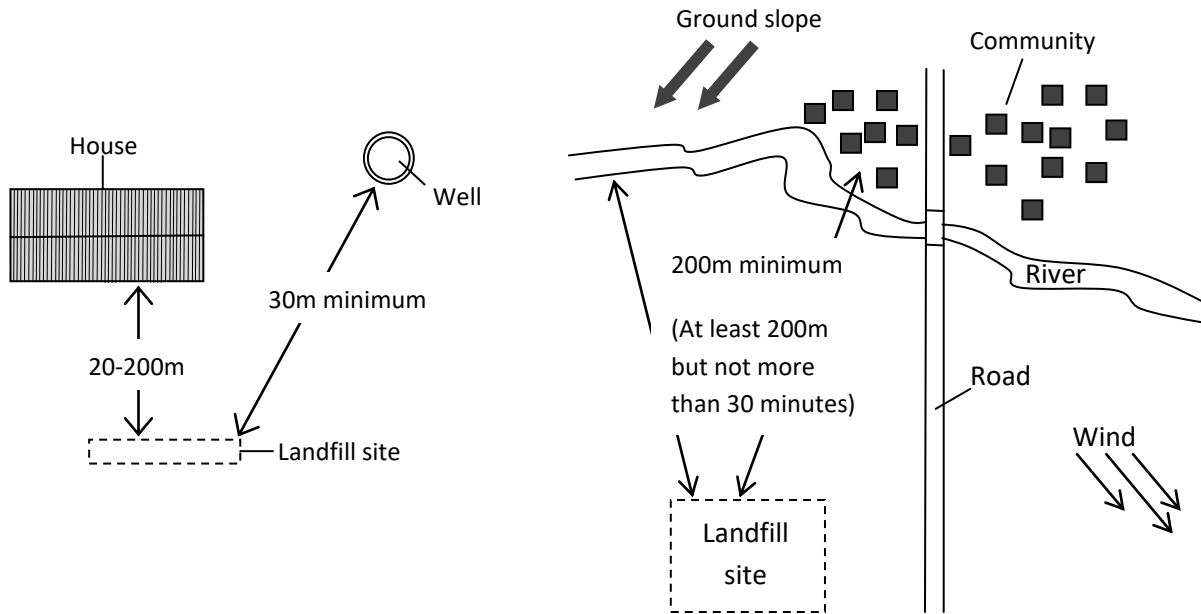

Figure 12-1: Landfill locations for household/compound (left) / community (right).

### Selecting the method of landfilling

The three basic methods of landfilling are: (1) trench method, (2) area method, and (3) mound method.

- Trench method:** Dig a trench, place solid waste in the trench, compact the waste, and cover with the excavated soil. Generally, only a portion of the trench is dug and filled with waste each day or week. The size of the trench will vary depending on the amount of waste to be disposed of and the equipment used for excavation.

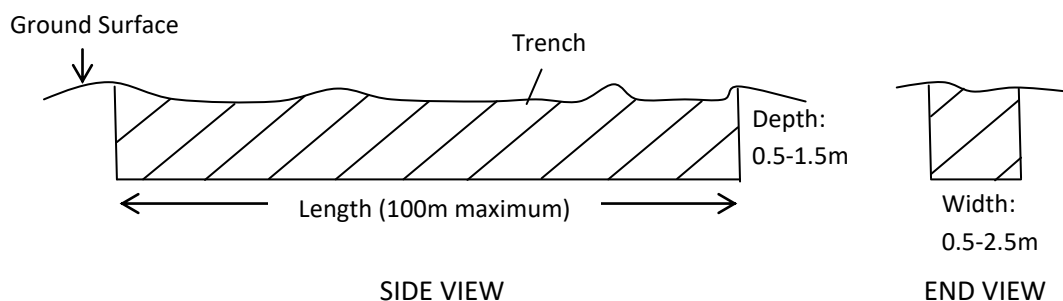

Figure 12-2: The trench method of landfill. Trenches are generally 0.5-2.5m wide 0.5-1.5m deep, and up to 100m long. The trench method is used where the ground is fairly flat or gently sloped and the soil on the site is easily excavated.

2. **Area method:** Raise a natural depression or low area by placing solid waste in the depression, compacting it, and covering it with soil. Cover soil can be hauled from off-site or scraped from the bottom of the depression before waste material is placed in it.

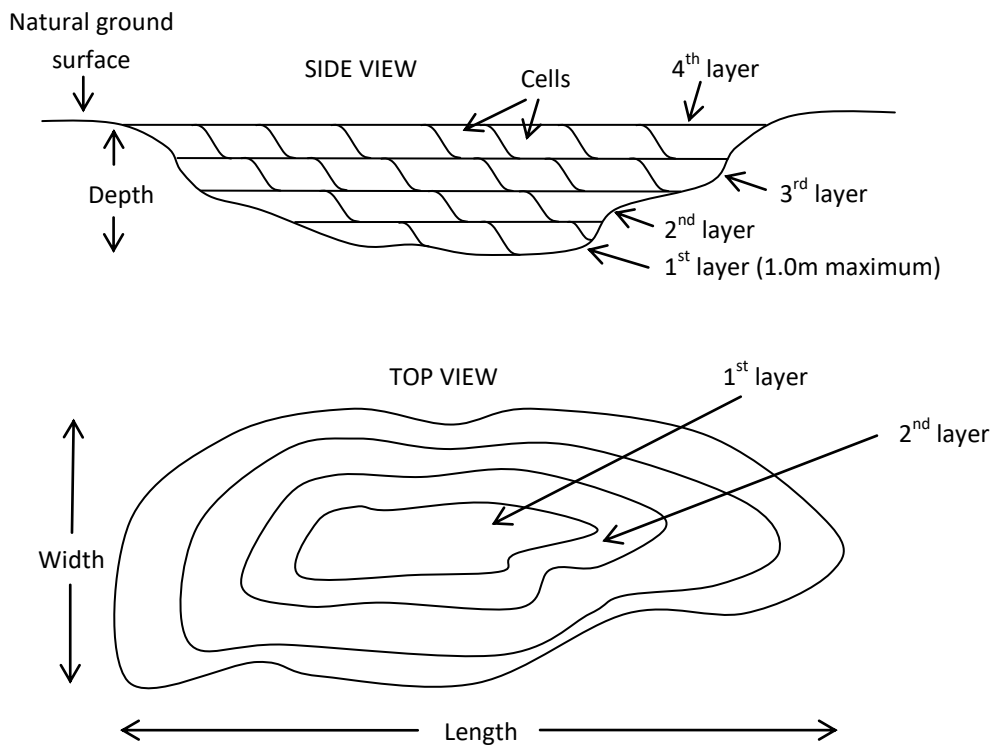

Figure 12-3: The area method of landfill. Although there are no design limitations to this type of landfill, waste is placed in strips of layers no higher than 1 metre. Each strip or layer may be composed of smaller sections called cells.

3. **Mound method:** Place solid waste in strips or layers no higher than 1 metre on top of relatively flat, hard ground and cover it with soil hauled from off-site. This method is generally used in areas difficult to excavate.

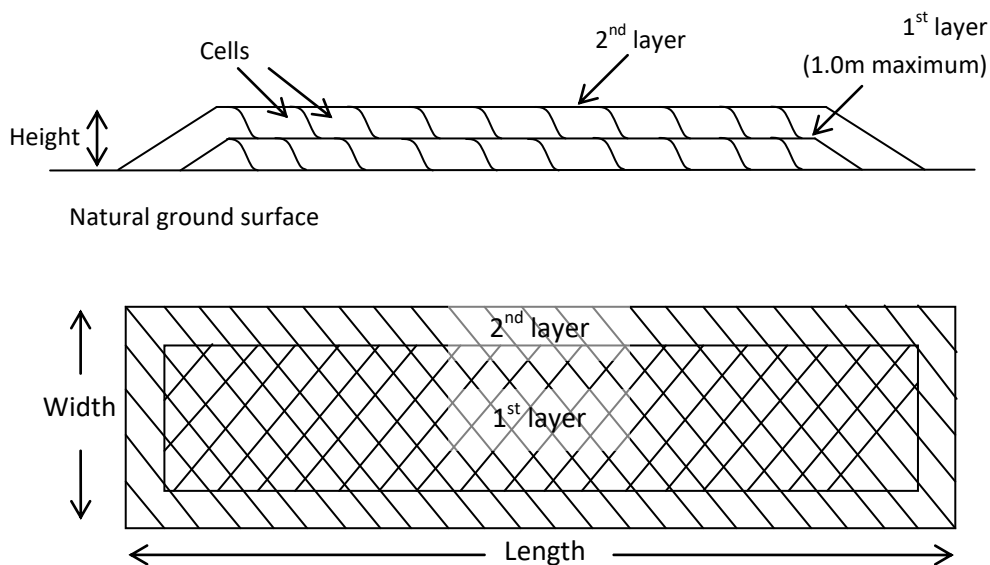

Figure 12-4: The mound method of landfill. There is no design limitation on landfill size.

## How to restore and improve an uncontrolled dumpsite

There are several steps you can take to rehabilitate an existing poorly-managed or uncontrolled dumpsite<sup>15</sup>:

1. Find someone to be responsible for managing the site, so one person has charge for the place.
2. Inform the community of improvements to the site, including any waste pickers who scavenge for materials at the site.
3. Make sure you have the equipment to improve the site, and the control over vehicle access to it through a single-entry point.
4. Ensure there is a single working face in an area of the site that is not burning and establish a road suitable for traffic leading to it.
5. Control waste disposal: allocate and control where loads are disposed of and stop end-tipping – the pushing of waste over an extended slope, where the waste is un-compacted and can burn.
6. Spread the waste in layers of a maximum 1 metre and compact as best possible with the machinery available.
7. Extinguish fires in other parts of the site by exposing smouldering areas and smothering them with soil (not water).
8. Develop a draining system that prevents runoff water from entering the waste body.
9. Create an operating plan (as simple as possible) that progressively levels areas of the landfill (always using a single working phase and some degree of compaction).
10. Cover deposited waste as well as possible with incoming soil, rubble or quenched ash. Vegetate if possible.
11. Most important is to negotiate with the waste pickers throughout the process, if they work on the site. They will be most affected by the proposed rehabilitation and are able to cause major problems on site if they feel that their livelihood is threatened. Consequently, they must be made part of the solution. This is achieved by:
  - recognising the fact that they are on site and are there to stay;
  - formalising the right for the regular or career waste pickers to operate on-site in a controlled manner;
  - developing a working relationship that is agreed by the recognised leader of the waste pickers and the site manager.



***Implementing a waste collection system (see How-to guide 11: How to collect waste safely and efficiently) and a safe waste disposal site are two of the most impactful activities that communities can undertake to protect their health and keep the neighbourhood clean.***

---

<sup>15</sup> UN-Habitat (2010) *Solid Waste in the World's Cities*, Keysheet 8, Phasing out open dumps.