



# MIAMI FILTER

MANUFACTURER OF WATER TREATMENT SYSTEMS

## INSTRUCTION MANUAL

MANUAL CONTROL

# VCOM SERIES



NATIONAL  
SANITATION  
FOUNDATION



UNDER WRITER  
LABORATORIES

7384 Commercial Circle Fort Pierce, FL 34951  
Ph 772-466-1440 Toll Free 888-642-6482 Fax 772-466-0364  
[www.miamifilter.com](http://www.miamifilter.com)

## INDEX

	Page
RECEIVING INSPECTION.....	3
WARNING – LIFTING LUG.....	4
FILTER ROOM LAYOUT DIAGRAM.....	5
TANK INSTALLATION.....	6
SIGHT GLASS.....	11
ADDING MEDIA.....	12
OPERATING INSTRUCTIONS – VCOM SERIES	13
DRAIN AND WINTERIZING PORTS.....	18
SACRIFICIAL ANODE.....	19
EMERGENCY RELIEF VALVES.....	20
FINAL PAINTING.....	21
TROUBLESHOOTING GUIDE.....	22
LIMITED WARRANTY.....	25
DAILY LOG.....	26
PACKING LIST.....	27

## RECEIVING INSPECTION

The material in this shipment was factory inspected prior to shipment and was fabricated in accordance with approved drawings and/or information furnished to us.

Our responsibility for the shipment terminated when we turned it over to the freight carrier. So to protect your interest, we suggest that you check the shipment promptly upon arrival.

- **DAMAGE CLEARLY VISIBLE:** If the shipment is obviously damaged upon arrival, please have the freight agent indicate such damage immediately on both the receipt and on the freight bill.
- **DAMAGE NOT INITIALLY APPARENT:** If the shipment is received in apparent good condition, but after opening the crates or boxes the contents are found to be damaged, call the freight agent or adjuster promptly to view the same. If possible, take pictures of the damaged contents. Have the freight agent make a notation of such previously unnoticed damage on the freight bill.
- **FIELD REPAIR OF DAMAGE:** Do not attempt field repairs to damaged equipment. Contact us for corrective action. Failure to inform MIAMI FILTER, INC. may deem all warranties null and void.
- **CLAIMS FOR DAMAGE (TO FREIGHT CARRIER):** Make your claims promptly as many carriers will not accept claims after a reasonable length of time. MIAMI FILTER, LLC is willing to assist you in any way to collect claims for damage or loss. However, we do not assume any responsibility for the collection. As we cannot guarantee delivery, any claim account for loss or damage is not deductible from MIAMI FILTER, INC. invoices. Therefore, all invoices are payable even during the claim adjustment period.
- **SHORTAGE OR DISCREPANCY:** All boxes and bags should be promptly opened and inspected upon arrival. If the contents received do not correspond with quantities indicated on the Freight Bill and/or Bill of Lading, or any other discrepancies are found, contact MIAMI FILTER, INC. promptly.
- **CLAIMS FOR SHORTAGE OR DISCREPANCY (TO MIAMI FILTER):** All claims must be made within 30 days after receipt of shipment. Charge backs are not authorized without prior approval from MIAMI FILTER, INC.. Should our records indicate that a claim is valid, we will advise you of corrective actions or arrange to make the necessary repairs. If our personnel perform a Field Inspection and it is found that it was not a factory error, the cost of the Field Inspection will be charged to you.

Your cooperation in the above procedures is needed and appreciated.

Thank you for choosing MIAMI FILTER, INC.!

**WARNING – LIFTING LUG**

On the top head of each VCOM-series filter vessel are two (2) Lifting Lugs. These lugs were

designed and installed to lift the filter vessel ONLY when it is in new condition and when it is completely empty. These Lifting Lugs were not designed to support a filter vessel when it is loaded with sand or water.

Failure to follow the above instructions could result in Lifting Lug failure and may result in serious personal injury, property damage, or fatalities.

When moving a loaded filter vessel, a professional crane operator should be consulted.

NEVER use the Lifting Lugs when attempting to move a loaded filter vessel.

**ALWAYS REMEMBER – SAFETY FIRST!**

TYPICAL FILTER ROOM LAYOUT FOR  
HI-RATE PRESSURE MEDIA FILTER

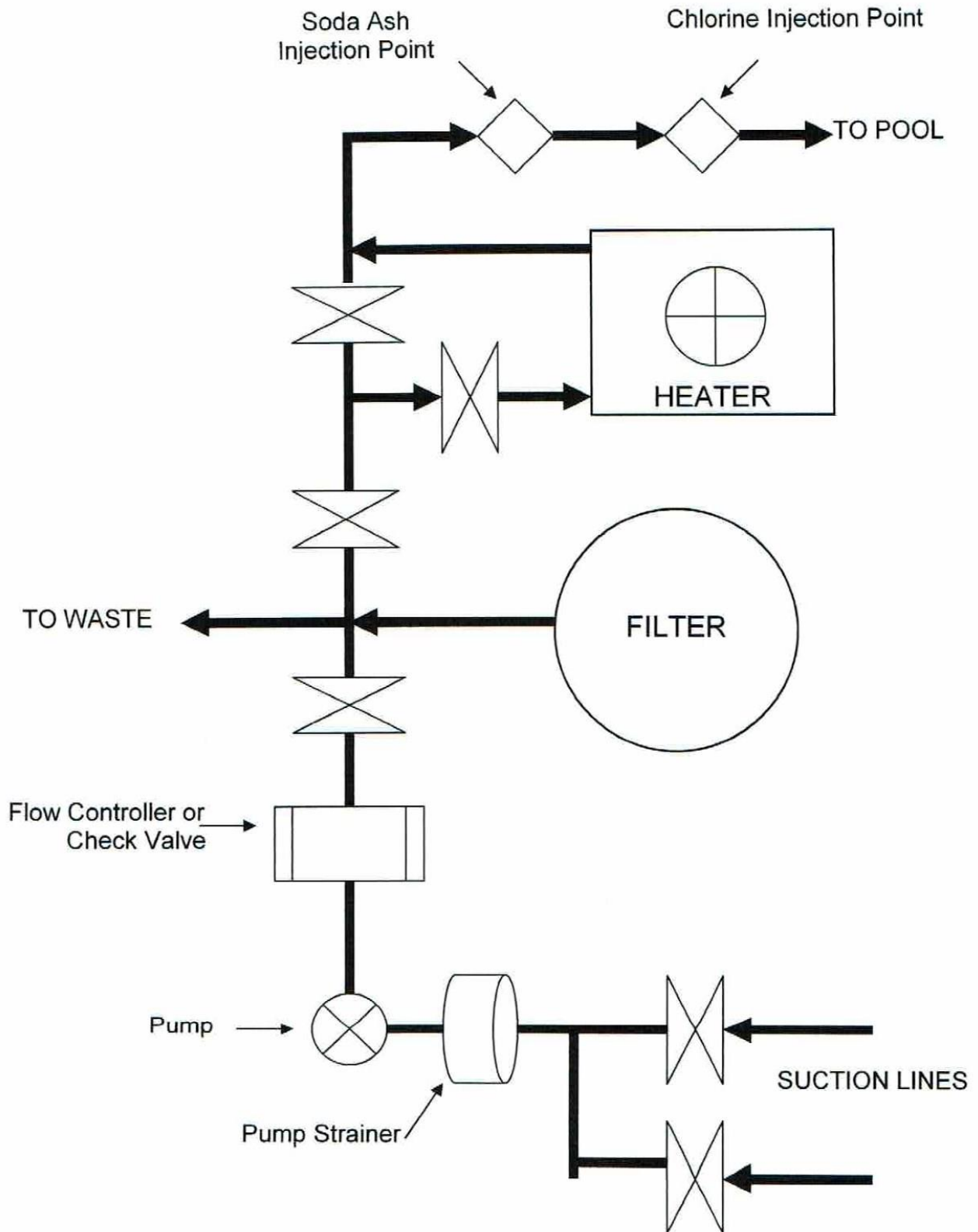

TANK INSTALLATION

All filtration systems including single, dual and triple systems are normally shipped without the face piping installed. It is recommended that the filter tank(s) be installed in the permanent operation position *before* installing the face piping. Standard filter tanks are equipped with non-adjustable strap or structural legs. Adjustable jacklegs are available as a factory option.

Before installing the filtration system, be certain the slab is designed and engineered to support the entire weight (with sand media and water) on the leg support areas. The face piping should be installed only after the filter(s) is in its permanent position(s). The correct amount of bolts and gaskets to mount the face piping are supplied in the accessory box. All system face piping should be installed with the backwash sight glass (pre-taped) located as close as possible to the top tee fitting. See installation on page 11.

On single lever units, the linkage is designed to be installed on the right hand side of the manifold (left side installation available upon request). On dual units, be certain the tanks are level and aligned before installing the face piping. Failure to do so could result in face piping stress cracking due to misalignment and excessive torque. On standard face piping the plumbing connections are as follows:

1. Top Flange = Waste Line (backwash)
2. Center Flange = Influent (from pump)
3. Bottom Flange = Effluent (return to pool or process)

When installing face piping to the filter tank, use the torque sequence shown below to avoid cracking the flanges.

Flange Size	Recommended Torque (Ft-lbs)	Flange Size	Bolt Holes	Bolt Diameter	Bolt Length (min.)	The following tightening sequence is suggested for the flange bolts.
½ - 1½	10 – 15 Ft-lbs	½	4	½	2	
2 – 4	20 – 30 Ft-lbs	¾	4	½	2	
6 – 8	33 – 50 Ft-lbs	1	4	½	2¼	
10	53 – 75 Ft-lbs	1¼	4	½	2¼	
12	80 – 110 Ft-lbs	1½	4	½	2¼	
12-24	110 Ft-lbs	2	4	5/8	3	
Bolts and Gaskets are not furnished.  Actual field conditions may require a variation in these recommendations. If higher torque is used, extra care is required to prevent damage to the plastic components. These torques are based on the use of two flat washers and a 1/8" thick full-face neoprene gasket.		2½	4	5/8	3¼	
		3	4	5/8	3¼	
		4	8	5/8	3½	
		5	8	¾	3¾	
		6	8	¾	4	
		8	8	¾	4½	
		10	12	7/8	5	
		12	12	7/8	5	
		14	12	1	5	
		16	16	1	5	
	18	16	1-1/8	5		
	20	20	1-1/8	6		
	24	20	1¼	8		
Based on use of two standard flat washers, standard nut and a 1/8" thick gasket.						CAUTION: UNNECESSARY OVERTORQUE WILL DAMAGE THE FLANGE  A neoprene full-face gasket, 1/8" thick is recommended. More resistant gasket materials should be used in systems handling highly aggressive chemicals.

TANK INSTALLATION (cont'd)

After placing tank(s) and installing face piping, the following accessories should now be installed.

1. **SINGLE LEVER CONTROL:** If the single lever control was ordered as an option, the control handle should now be installed. The control handle was removed and strapped to the linkage to avoid damage during shipment. To install control handle, remove the two  $\frac{3}{8}$ " x 3" shoulder bolts from the control clevis (mounted on third valve from top). Insert control handle into clevis until all pre-drilled holes in linkages, clevis and control handle are aligned. Before replacing shoulder bolts and tightening the linkages, the smooth shoulders of bolts must be coated with graphite grease or equivalent to protect surfaces during movement. For further information, see single lever control illustration in the manual.
2. **VALVES (Automatic air relief valve and emergency high pressure relief valve):** All necessary fittings are supplied to install both valves. Both valves are to be installed on  $\frac{3}{4}$ " F.I.P. coupling welded in the center of the top head using supplied tees and bushings. See illustration below for proper installation positions. The automatic air relief valve will automatically open to bleed out any air that is in the system and it will automatically close when it detects water. The small cap on top of the bleeder should be left slightly loose to allow the valve to function properly. The high-pressure relief valve is supplied in the event the internal tank pressure exceeds the design pressure. Standard tanks are designed for a 50 PSI working pressure. Because normal operating pressure may fluctuate, the emergency valve will open at 75 PSI. If the valve opens because of a high-pressure condition, it must be manually reset by pushing the small lever downward. Assemble as per illustration below:

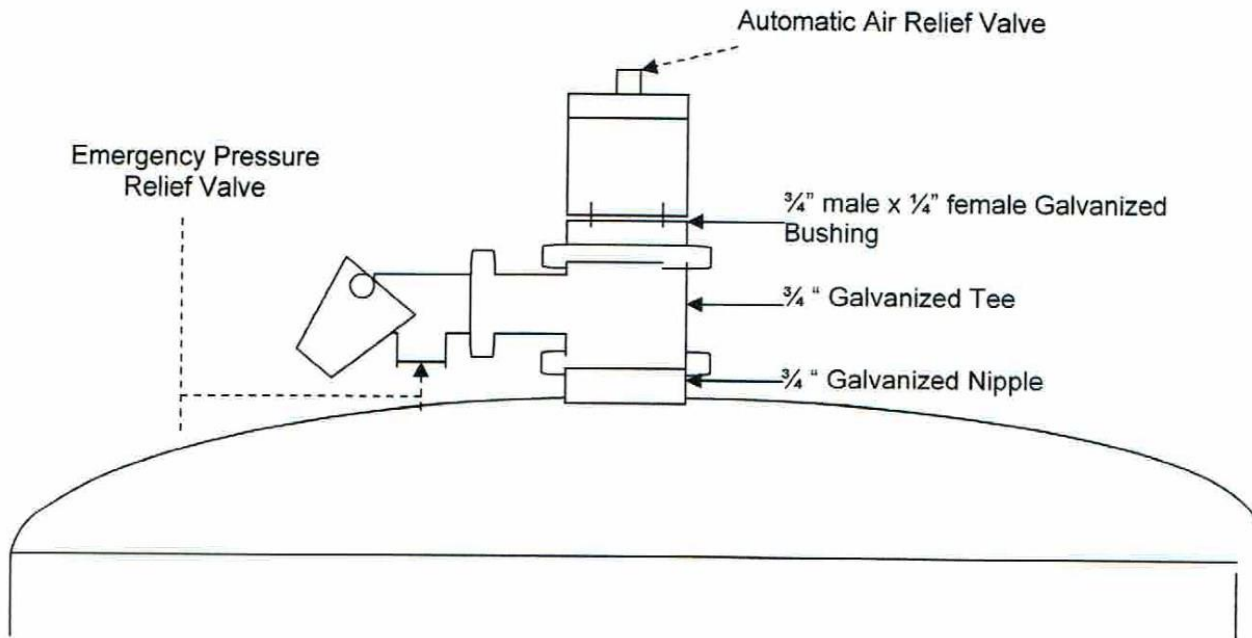
TANK INSTALLATION (cont'd)

3. **GAUGE PANEL AND TUBING INSTALLATION:** All components to install and tube the gauge panel assembly are supplied in the accessory box. To install gauge panel, first mount gauges in the panel and secure with a 2" flat bar brace across the back of both gauges. Lightly snug flat bar against back of gauges using  $\frac{3}{4}$ " nut and  $\frac{3}{4}$ " threaded rod (supplied). Attach the gauge panel assembly to the mounting bracket using the same  $\frac{3}{4}$ " threaded rod and the second  $\frac{3}{4}$ " nut (supplied). Attach the gauge panel assembly to the upper tank flange using the mounting bracket and two of the tank flange bolts.

**CAUTION:** Do not over tighten the pressure gauge support bar lock nut. Hand-Tighten Only! Too much force on the pressure gauges may crack the glass face on the pressure gauges.

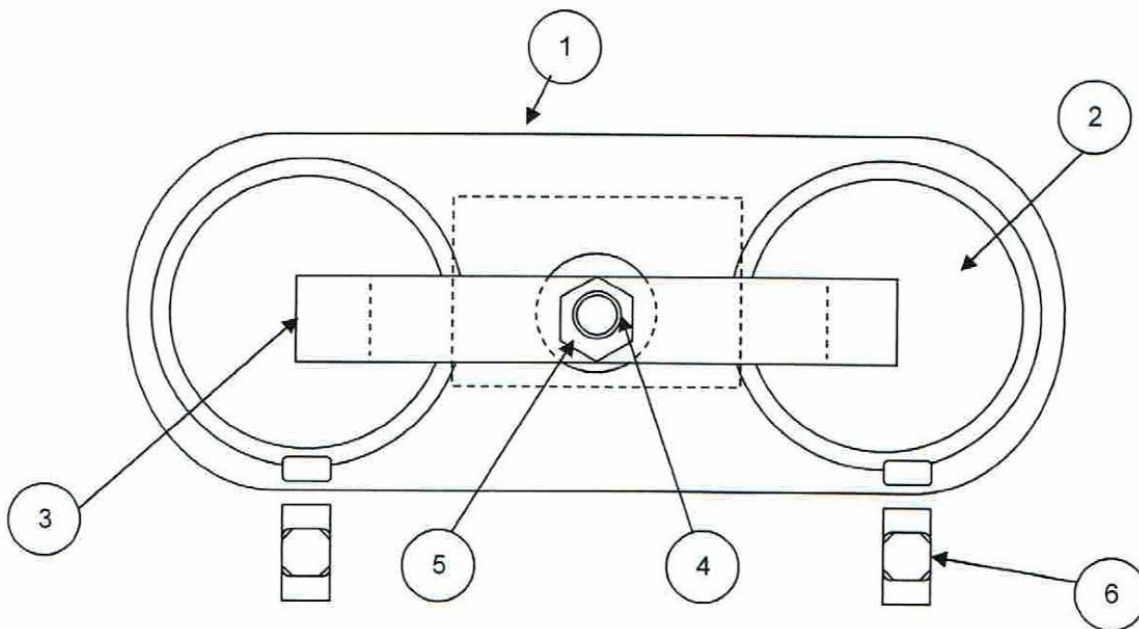

Differential Gauge Panel #15160		
Reference Number	Quantity	Description
1	1	Gauge Panel
2	2	0 – 60 PSI Pressure Gauges
3	1	Support Bar, Stainless Steel
4	1	$\frac{3}{4}$ " I.P.S. x 3" Threaded Rod
5	2	$\frac{3}{4}$ " I.P.S. Galvanized Lock Nut
6	2	$\frac{1}{4}$ " I.P.S. x $\frac{1}{4}$ " Tube Compress Fitting



TANK INSTALLATION (cont'd)

The Influent and Effluent gauge panel and tubing may now be installed. In the packing crate, locate two ¼" female compression fittings. The tubing will be cut from the roll supplied in the packing crate. Install one ¼" female compression fitting onto each gauge.

When installing the fitting, hold the gauge with a wrench, not by the glass. Connect the gauge marked "Effluent" to the ¼" compression fitting previously installed on the effluent manifold. Connect the gauge marked "Influent" to the ¼" compression fitting previously installed on the influent manifold.

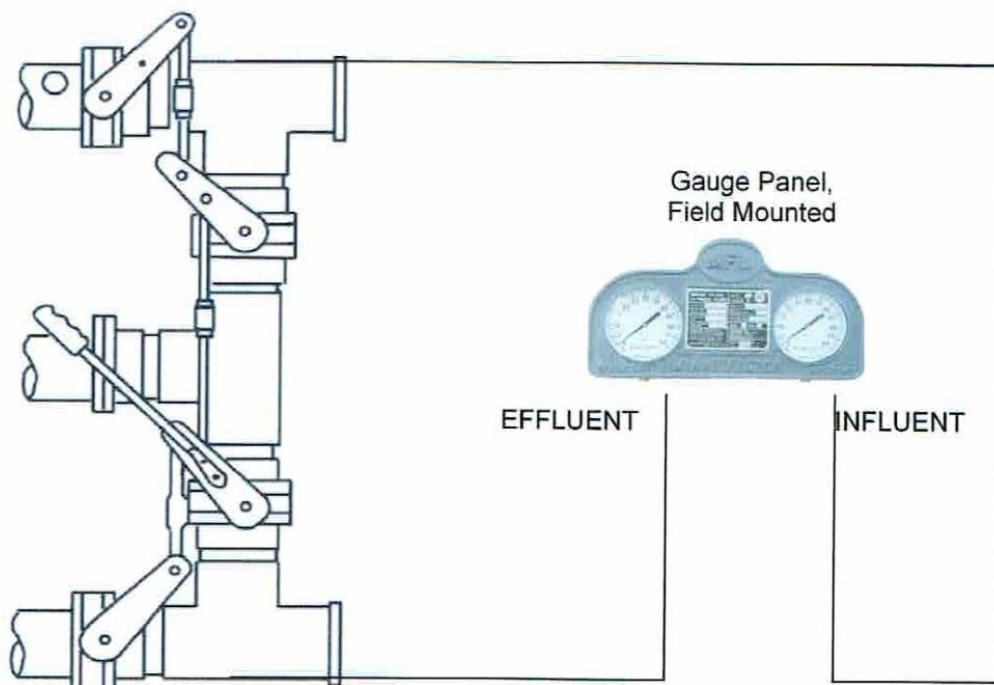

GAUGE PANEL TUBING CONNECTION DETAIL

MIAMI FILTER INC.  
TANK INSTALLATION (cont'd)

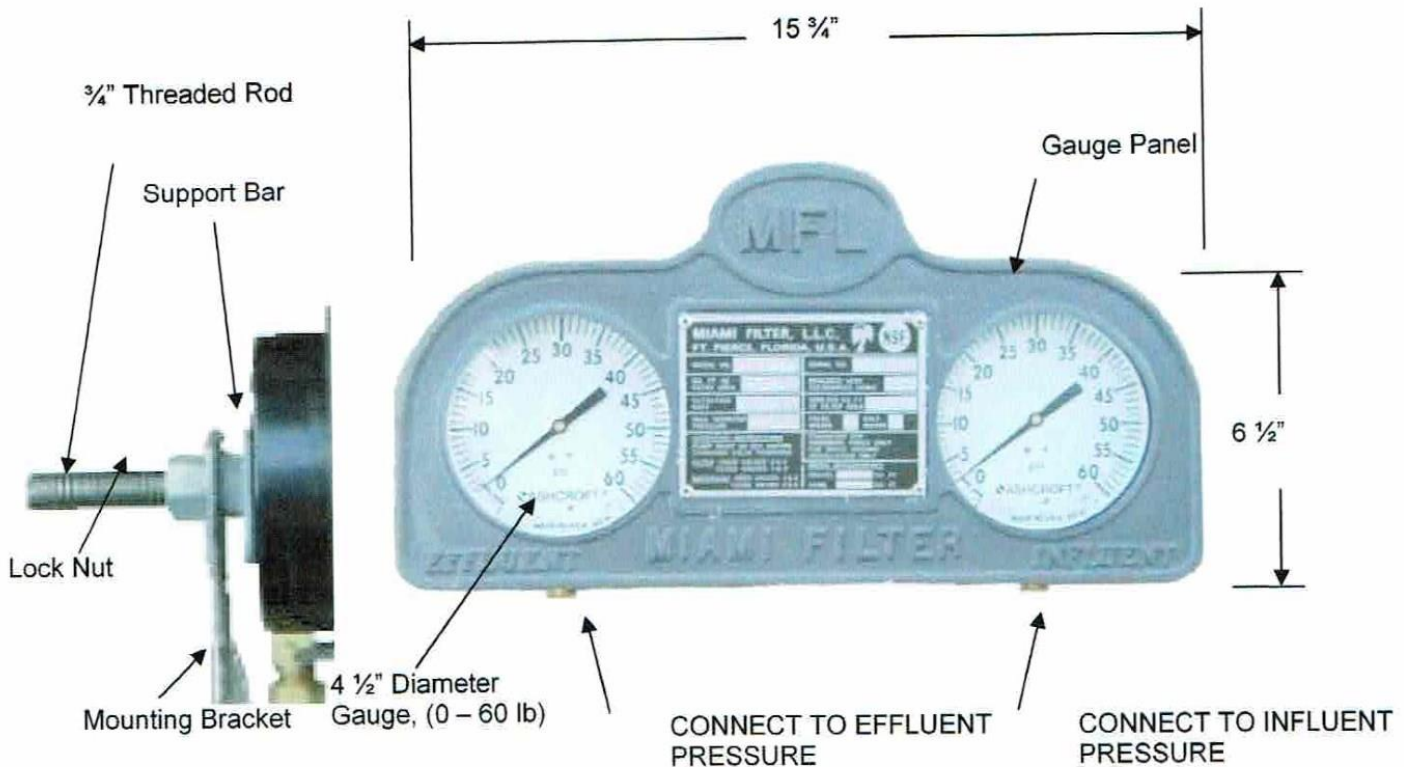

Filter Gauge Panel:

Gauge panel consists of two 4 1/2" diameter pressure gauges mounted in cast aluminum support panel. A 3/4" threaded rod and lock nuts are provided for the mounting of the panel. The panel has the words "Effluent" and "Influent" integrally cast under each gauge respectively.

Pressure gauges are typically 0 – 60 PSI reading with a 1/4" MIPS bottom connection.

## SIGHT GLASS INSTALLATION

The backwash sight glass may now be installed. On some units the sight glass is factory installed on the upper tee on the manifold. On larger units, the sight glass and a section of pipe with a 1 ½" threaded port is supplied. For field installation, the sight glass assembly should be installed as close as possible to the filtration system and may be installed in the horizontal or vertical position. Note the position of the diverting baffle in the diagram below.

**CAUTION: DO NOT EXCEED 50 PSI.**

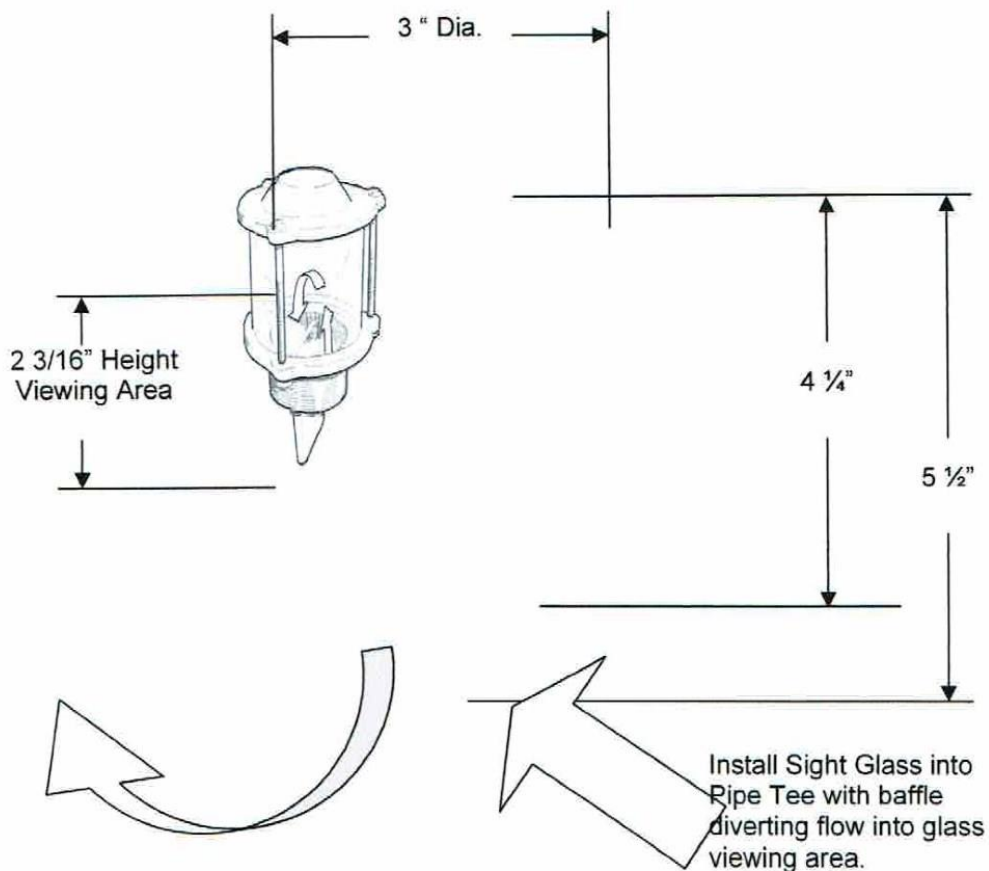

## SIGHT GLASS

## ADDING MEDIA TO A SAND FILTER

The filter media should consist of washed, clay-free gravel and sand. The gravel should be 1/8" x 1/4" and the sand should be #20 or 0.45 to 0.55mm type. Care should be taken when adding the media so that the lower lateral collection system is not damaged. All filtration systems are shipped with the internal piping installed and braced for support. Plastic shipping supports can remain in place and do not require removal.

**IMPORTANT:** Before adding media, the internal plumbing should be inspected for damage during shipment – *this is a very critical step*. Be sure to repair any damaged internal plumbing prior to loading media.

Fill the tank with water to approximately one foot above the lower collection system plumbing. After adding water, carefully pour in the required amount of gravel through the manhole. After gravel is added, level the surface through the manhole using a shovel, rake or 2 x 4 board. After loading and leveling the gravel, the sand should be installed in the same manner. After all media is loaded and leveled, the manhole cover and gasket should be installed and tightened. **NOTE:** The manhole is connected by a safety chain to prevent it from falling onto the internal piping while media is being loaded.

## ANNUAL MAINTENANCE AND INSPECTION

It is good maintenance to inspect and clean the sand at least once a year by skimming the sand bed with a rake or loosening by stirring the surface of the sand, then backwashing. If necessary, accumulations of hair or other foreign material that will not backwash can be removed by skimming about 2" of sand off the surface and replacing with #20 filter sand. This will ensure effective operation for the following season. Occasionally, sand may cake or solidify due to hard water conditions. If this occurs, Hydrochloric Acid (also called Muriatic Acid) and agitation will loosen up the sand. Water conditions in the pool should be adjusted to prevent calcification.

After 6 or 8 weeks of service, a marked improvement in length of cycle and flow rate will be noticed. This is due to the natural alignment of sand particles caused by backwash.

OPERATING INSTRUCTIONS  
VCOM-SERIES BUTTERFLY VALVE UNITS 2 ½" THRU 10" WITH MANUAL CONTROL

**IMPORTANT: ALWAYS TURN OFF PUMP WHEN OPERATING VALVES OR CLEANING PUMP STRAINER.**

1. INITIAL START UP; NEW POOL

VALVE POSITIONS: Open valves # 1 and # 2. Close valves # 3 and # 4.

PURPOSE: To remove dirt and debris from pipes.

EXPLANATION: When plumbing is attached as per illustration, water will pass from pump directly to waste, permitting thorough cleaning of all suction pipelines. Draw water from one suction line at a time (at least 1 full minute for each line), then clean pump strainer and repeat with all suction lines open until strainer remains clean – this will indicate that the pipes are clean.

2. BACKWASHING

VALVE POSITIONS: Open valves # 1 and # 3. Close valves # 2 and # 4.

PURPOSE: To clean sand and gravel and remove trapped impurities.

EXPLANATION: When plumbing is attached as per illustration, water will pass from pump to the bottom of the filter bed and scrub the media. This operation should be performed at least once a week for a period of 3 to 5 minutes or until sight glass (located in the waste line) shows reasonably clear water. Heavier bather load may require more frequent backwashing until the particles of sand align themselves.

3. FILTERING

VALVE POSITIONS: Open valves # 2 and # 4. Close valves # 1 and # 3.

PURPOSE: To filter pool water

EXPLANATION: As pool water is forced through the sand bed from top to bottom, turbidity (cloudiness) and suspended matter is filtered from the water by getting caught in the media. As more dirt and suspended matter fill the spaces between sand particles, water flow will be reduced. The water pressure above the sand bed will increase and the pressure below the sand bed will decrease, eventually requiring a backwash. Differential pressure can be noted on the gauge panel.

**CAUTION: DO NOT CHANGE VALVE SETTINGS WHEN PUMP IS OPERATING.**

**ILLUSTRATION OF TYPICAL VALVE NEST**  
 (Shown here in "BACKWASH" Mode)

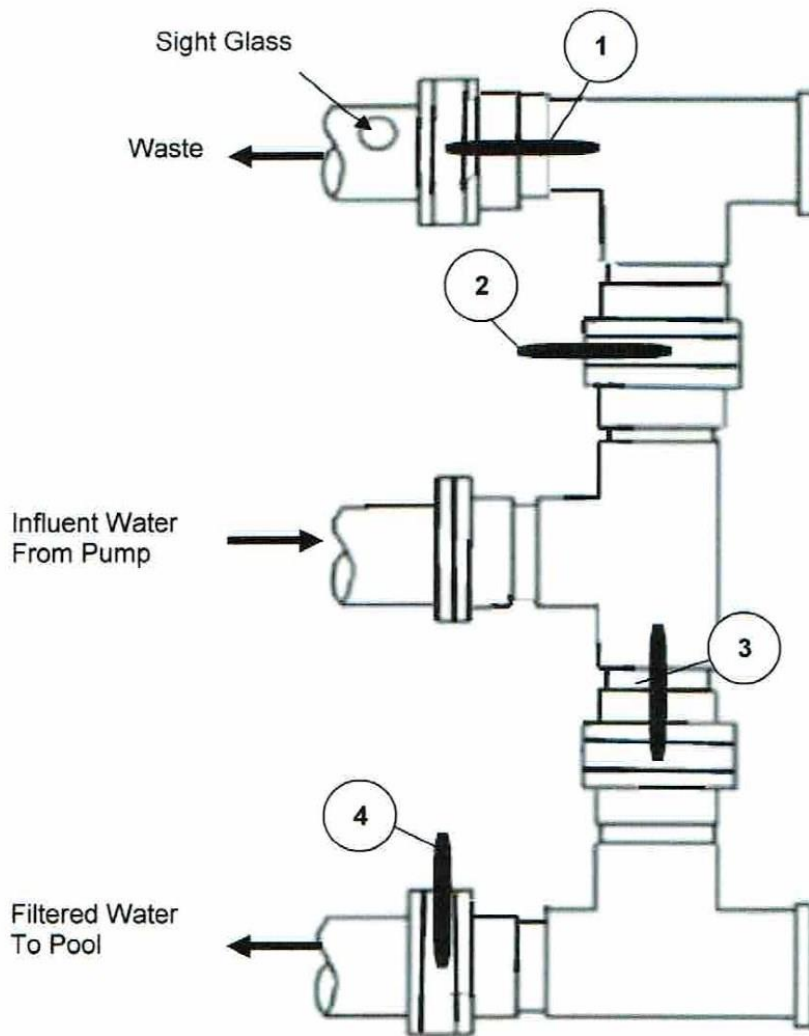

**Legend: Valve Positions**

1		CLOSED
	—	OPEN
2		OPEN
	—	CLOSED
3		OPEN
	—	CLOSED
4		CLOSED
	—	OPEN

## OPERATING INSTRUCTIONS SINGLE LEVER VALVE CONTROL UNITS

**NOTE:** Single lever operating restricts valve functions to “Filter” and “Backwash” modes only. On filters equipped with a single lever control, the operating sequence is as follows:

**FILTRATION:** Valve handle pushed upward as far as possible and with the supplied Lock pin inserted.

**BACKWASH:** Remove Lock Pin and pull single lever valve downward as far as possible until resistance is felt. Hold in the backwash position approximately 3 to 4 minutes or until the backwash sight glass appears reasonably clear.

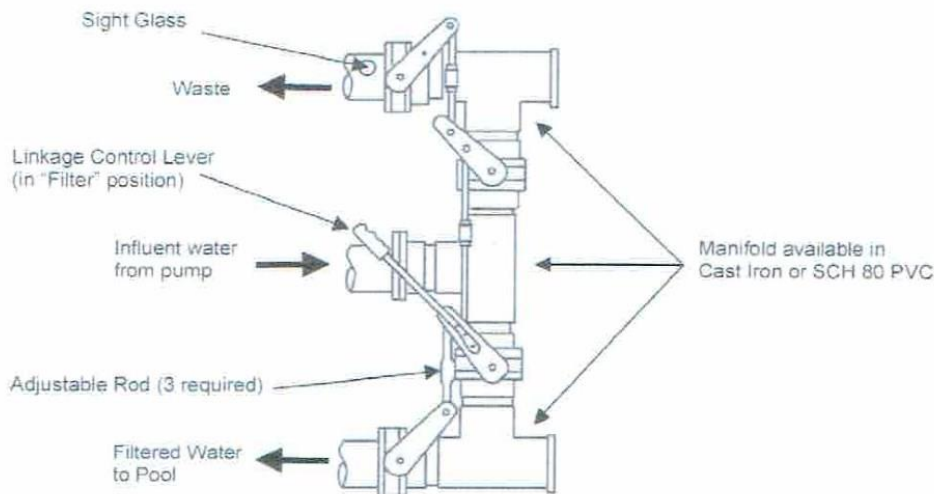

**NOTE:** When the single lever control is placed in the “FILTER” position, the supplied lock pin **MUST** be inserted in the pre-drilled holes located in valve and clevis # 1. If this procedure is not followed, pump vibration could cause the single lever control to move from the “Filter” position to the “Backwash” position, resulting in massive water loss.

**PROCEDURE FOR ADJUSTING LINKAGE:** All butterfly valves supplied with the system have a slot on the end of the stem or shaft indicating the position of the disc.

To adjust linkage, remove the respective clevis, bearing, bolt and nut. Place the indicator mark in desired position. Loosen the respective jam nut. The linkage may now be extended or retracted to the necessary length into the adjustment coupling.

Replace the bearing bolt and nut. The assembly is now ready for operation.

OPERATING INSTRUCTIONS  
SINGLE LEVER VALVE CONTROL UNITS (Cont'd)

**INSPECTION AND MAINTENANCE:** All moving parts on the single lever control should be inspected monthly for fatigue or stress fractures. This is because chemical conditions of water can sometimes cause corrosion. If corrosion occurs on the butterfly valves, more torque will be required to operate them. This higher torque requirement will result in a heavier load upon the single lever control assembly, especially on the shear pins that connect the clevis to the butterfly valves. These pins should be monitored for signs of corrosion or fatigue and should be replaced as necessary. All moving parts on the linkage should be greased or coated with protective spray monthly.



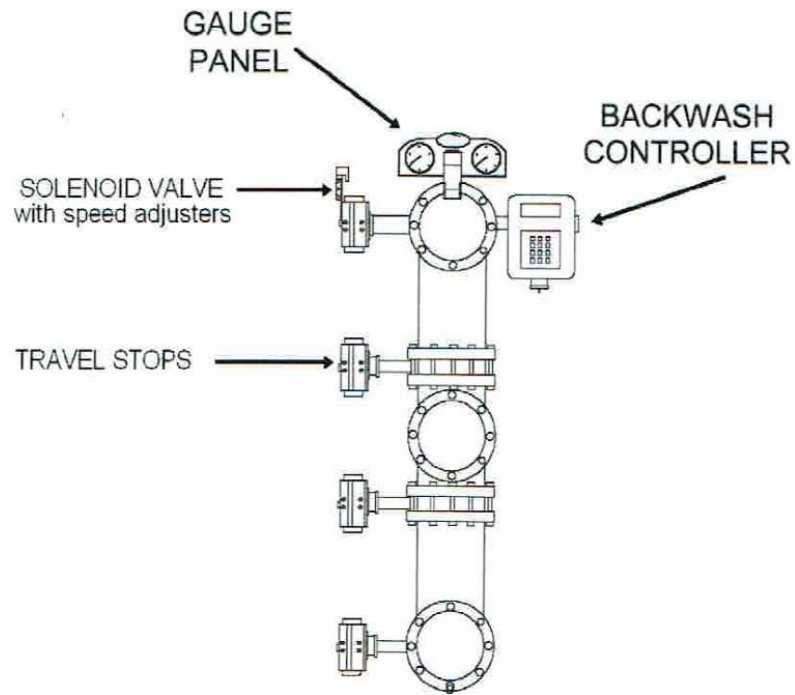

AUTOMATIC  
OPTION

### DRAIN AND WINTERIZING PORTS

Located on the bottom head of all VCOM-series filter tanks are two ports as follows.

**ONE 3" MEDIA DRAIN PORT:** this port is used only when necessary to drain all the media out of the filter tank.

**ONE 1 ½" WINTERIZING DRAIN PORT:** this port is screened on the inside of the filter and is used to drain the water completely without draining any of the media.

**CAUTION:** Before removing the drain or winterizing plugs, ensure that the pump is off and bleed all pressure from the filter system. To bleed air pressure, open manual or automatic bleeders and check pressure gauges to verify that there is no pressure left in the system.

**DANGER: FAILURE TO BLEED PRESSURE FROM TANK BEFORE REMOVING EITHER PLUG CAN RESULT IN SERIOUS INJURY OR FATALITY,** as the plug can pop out with very high velocity if the tank is still under pressure.

**REMEMBER: SAFETY FIRST**

### EMERGENCY RELIEF VALVES

Supplied with each Miami Filter unit is a ¾" Pressure Relief Valve (PRV), included in the components box. This valve should be installed at the top center coupling on the top head. The PRV was designed strictly as an automatic emergency safety device. It should never be used as an operating control. The valve is ASME-rated and has been pre-set by the factory to open at 75 PSI. Repair or alteration of this valve in any way is prohibited.

CAUTION: If the PRV has to be replaced for any reason, ensure that the pump is off and bleed all pressure from the filter system. To bleed air pressure, open manual or automatic bleeders and check pressure gauges to verify that there is no pressure left in the system.

DANGER: FAILURE TO BLEED PRESSURE FROM TANK BEFORE REMOVING PRV CAN RESULT IN SERIOUS INJURY OR FATALITY, as the PRV can pop out with very high velocity if the tank is still under pressure.

### FINAL PAINTING OF VCOM-SERIES TANKS

All standard VCOM-Series Filter tanks are coated with high solids Zinc paint. To activate the corrosion warranty, the tanks should be top-coated with a durable acrylic enamel, polyurethane, or epoxy paint.

Paint will help protect the exposed steel surface by preventing corrosive agents from coming in contact with the surface of the filter vessel.

#### REQUIRED QUANTITY OF PAINT

Theoretically, 1 gallon of paint will cover 1,600 square feet of surface with 1 mil (0.001) inch thick coat when it is *wet*.

The *Dry Thickness* is determined by the solids (non volatile) content of the paint, which can be found in the specifications on the label, or in the supplier's literature. For example, if the content of solids (by volume) is 60%, then the maximum dry coverage to maintain a dry film thickness of 1 mil will theoretically be  $1600 \text{ sq ft} \times 0.60 = 960 \text{ sq. ft. per gallon}$ .

## .TROUBLESHOOTING GUIDE

There are no moving parts inside any Miami Filter vessel, which eliminates the need for frequent maintenance.

### MOST COMMON PROBLEMS

There are two common problems that can occur with a filter vessel;

#### 1. MEDIA DISCHARGED INTO POOL

CAUSES: A. Underdrain damaged or incorrectly installed.  
B. Incorrect media used (i.e., media is too fine).

SOLUTION: A. Remove media (using dump port), inspect underdrain and repair if necessary and re-install media  
B. Check media size. If incorrect size was used, remove (using dump port) and replace with proper grade.

#### 2. POOL WATER NOT CLEARING UP (i.e., remains cloudy or dirty)

CAUSES: A. Incorrect media used.  
B. Flow rate in excess of 20 GPM.  
C. Problem with pool chemistry.  
D. Mud ball.  
E. Problem with original water source.

SOLUTION: A. Inspect media grade. If incorrect, remove and replace with correct grade.  
B. Check flow rate and adjust if necessary.  
C. Consult local water chemist.  
D. Consult factory service representative.  
E. Special pre-treatment or special post-treatment (after filling) of pool water may be required. Consult local water chemist or factory representative.

### PROCEDURE FOR ADJUSTING LINKAGE

All butterfly valves supplied with the system have a slot on the end of the stem or shaft indicating the position of the disc.

To adjust linkage, remove the respective clevis, bearing, bolt and nut. Place the indicator mark in desired position. Loosen the respective jam nut. The linkage may now be extended or retracted to the necessary length into the adjustment coupling.

Replace the bearing bolt and nut. The assembly is now ready for operation.

TROUBLESHOOTING GUIDE (Cont'd)

<b>PROBLEM: FREQUENT BACKWASH INTERVALS</b>	
PROBABLE CAUSES	SOLUTION
A. Backwash flow or duration not adequate.	A. Re-adjust backflush flow and/or increase duration of backflush.
B. Insufficient media depth.	B. Add media to recommended level.
C. Incorrect media used – too fine.	C. Replace with recommended media
D. Pressure differential switch set too low.	D. Re-adjust pressure switch to 15 PSI higher than clean bed differential.
E. Higher concentration of contaminants in water source.	E. Reduce flow rate
F. Pool chemistry not adequate in preventing algae growth.	F. Maintain proper pool chemistry or consult pool service technician.

<b>PROBLEM: CONSISTENTLY HIGH PRESSURE DIFFERENTIAL – SYSTEM WILL NOT BACKWASH</b>	
PROBABLE CAUSES	SOLUTION
A. Incoming air pressure below 50 PSI – automatic backwash valves cannot activate (automatic models only)	A. Correct low air pressure condition; supply 50 PSI to microprocessor stager.
B. Media level too high, causing inadequate restrictive backwash flow.	B. Remove media to recommended level.

<b>PROBLEM: SAND LOSS TO WASTE</b>	
PROBABLE CAUSES	SOLUTION
A. Backwash rate is too high.	A. Reduce backwash flow rate.
B. Improper sand size.	B. Replace with recommended grade.

TROUBLESHOOTING GUIDE (Cont'd)

<b>PROBLEM: CONTINUOUS BACKWASH FLOW TO WASTE</b>	
PROBABLE CAUSES	SOLUTION
A. Obstruction inside valve preventing valve from closing waste port.	A. Remove obstruction.
B. Damaged valve seat.	B. Replace valve seat.
C. Single lever control not in the "Filter" position.	C. Return single lever control to "Filter" position and secure with lock pin.

<b>PROBLEM: MEDIA SAND APPEARS DOWNSTREAM</b>	
PROBABLE CAUSES	SOLUTION
A. Incorrect media used – too fine	A. Replace with recommended media.
B. Underdrain system broken or damaged.	B. Repair or replace.
C. Air in filter(s) causing bed disruption.	C. Check Air Relief Valve operation. Replace if necessary.
D. Excessive flow through filter	D. Reduce flow rate.

<b>PROBLEM: SYSTEM NOT BACKWASHING</b>	
PROBABLE CAUSES	SOLUTION
A. Inadequate air pressure to actuator (Automatic Models only).	A. Supply minimum 50 PSI air pressure to actuator.
B. Butterfly valve leaking internally.	B. Replace butterfly disk seat.
C. Power to microprocessor disrupted.	C. Check and/or restore power to microprocessor.

**MIAMI FILTER, INC.**

**7384 COMMERCIAL CIRCLE  
FORT PIERCE, FLORIDA 34951  
Ph: 772-466-1440 Fax: 772-466-0364  
[www.miamifilter.com](http://www.miamifilter.com)**

**LIMITED WARRANTY FOR VCOM MODELS**

This filter system was factory inspected before shipment. To the original purchaser of this system, MIAMI FILTER, INC. warrants this product to be free of defects in material and workmanship for a period of one (1) year. Thereafter, the filter vessel and PVC internals carry a five (5) year warranty on a prorated basis.

The manufacturer's obligation under this warranty shall be limited to the repair or replacement (at the manufacturer's option) of any part that, upon examination by the manufacturer proves to be defective in materials and/or workmanship under normal usage. All such repairs or replacements to be performed by the manufacturer upon return pre-paid to the manufacturer.

This warranty is expressly conditioned upon the correct installation and application of the product in the manner recommended by the manufacturer, where installation and application is the responsibility of the purchaser.

Parts which fail or become defective during the warranty period, except as a result of freezing, negligence, improper installation, use, or care, shall be repaired or replaced at the manufacturer's option, without charge, within 90 days of the receipt of defective product, barring unforeseen delays.

MIAMI FILTER, INC. shall not be responsible for cartage, removal and/or re-installation labor or any other such costs incurred in obtaining warranty replacements.

The forgoing warranty does not apply to components manufactured by other manufacturers. For such components, the warranty established by the respective original equipment manufacturer (OEM) will apply.

Some States do not allow limitations on how long an implied warranty lasts, or the exclusion or limitation of incidental or consequential damages, so the above limitations or exclusions may not apply to you.

This warranty gives you specific legal rights and you may also have other rights that vary from State to State.

The remedy provided by this warranty shall be exclusive.

Respectfully,

Shane Mulvey  
COO, Miami Filter, INC.



**OPERATIONS DAILY LOG**

		PRESSURE		pH	Chlorine PPM	CHEMICAL ADDITION (LBS)			Backwash Time	TEMPERATURE				
		Influent	Effluent			Acid	Soda Ash	Chlorine		Air	Water	Flow Rate	Filter Rate	Bather Load
SAT	AM													
	PM													
SUN	AM													
	PM													
MON	AM													
	PM													
TUES	AM													
	PM													
WED	AM													
	PM													
THUR	AM													
	PM													
FRI	AM													
	PM													

OPERATING LOG FOR: \_\_\_\_\_ WEEK ENDING: \_\_\_\_\_

PACKING LIST

VCOM-SERIES VERTICAL TANKS WITH PIPING

Customer:		
Filter Type:		
Quantity:		
ITEM	Required Per Tank	Total Shipped
Instruction Manual	1	
0 – 60 PSI Pressure Gauges	2	
GAUGE Mounting Panel with Data Plate	1	
GAUGE Panel Mounting Brackets	1	
Poly tubing 1/4"	2	
Poly Tubing Female Connector	2	
Ply Tubing Male Connector	2	
Backwash Sight Glass 1 1/2"	1	
Flange Gaskets – Size _____	_____	
Hex Head Bolts – Size _____	_____	
Hex Nuts – Size _____	_____	
Washers – Size _____	_____	
Tee with Nipple 3/4"	1	
Automatic Relief Valve with Busing	1	
Pressure Relief Valve (PRV) 75 PSI	1	
Other(Specify) _____	_____	

Packed By: \_\_\_\_\_ Date: \_\_\_\_\_

Tank Serial Numbers: \_\_\_\_\_

PLEASE REPORT ALL SHORTAGES PROMPTLY

Notes:  
REV:1/1/2013