

Dimension

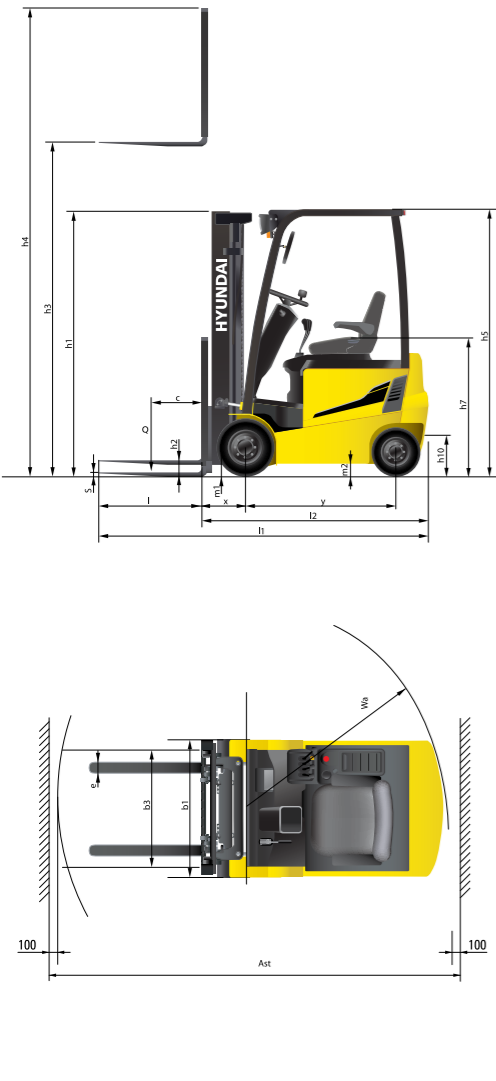

Specification

Identification					
1.1	Manufacturer	HYUNDAI			
1.2	Manufacturer's type designation	16B-9	18B-9	20B-9	
1.3	Drive : electric (battery or mains), diesel, petrol, fuel gas, manual	Electric	Electric	Electric	
1.4	Type of operation : hand, pedestrian, standing, seated, order-picker	Seated	Seated	Seated	
1.5	Load capacity / rated load	Q kg	1,600	1,800	2,000
1.6	Load center distance	c mm	500	500	500
1.8	Load distance, center of front axle to fork	x mm	360	360	365
1.9	Wheelbase	y mm	1,355	1,440	1,440
Weights					
2.1	Service weight	kg	3,150	3,275	3,480
2.2	Axle loading, loaded front / rear	kg	4,200 / 550	4,478 / 597	4,850 / 630
2.3	Axle loading, unloaded front / rear	kg	1,585 / 1,565	1,603 / 1,672	1,650 / 1,830
Wheels, Chassis					
3.1	Tires : solid rubber(V), superelastic(SE), pneumatic(P), polyurethane(PE)	SE	SE	SE	
3.2	Tires size, front(ϕ x width)	18x7-8	200 / 50-10	200 / 50-10	
3.3	Tires size, rear(ϕ x width)	16x6-8	16x6-8	16x6-8	
3.5	Wheels, number front rear(x = driven wheels)	2x / 2	2x / 2	2x / 2	
3.6	Track width, front	mm	895	905	905
3.7	Track width, rear	mm	880	880	880
Basic Dimensions					
4.1	Mast / fork carriage tilt forward / backward	degrees	5 / 7	5 / 7	5 / 7
4.2	Lowered mast height	h1 mm	2,120	2,129	2,129
4.3	Free lift height	h2 mm	35	35	40
4.4	Lift height	h3 mm	3,325	3,325	3,330
4.5	Extended mast height	h4 mm	4,320	4,320	4,320
4.7	Overhead guard (cab) height	h5 mm	2,065	2,065	2,065
4.8	Seat height / Standing height	h7 mm	982	982	982
4.12	Coupling height	h10 mm	250	250	250
4.19	Overall length	l1 mm	2,935	3,020	3,030
4.20	Length to face of forks	l2 mm	2,035	2,120	2,130
4.21	Overall width	b1 mm	1,074	1,105	1,105
4.22	Fork dimensions	l / e / s mm	900x100x35	900x100x35	900x100x40
4.23	Fork carriage ISO 2328, class / type A, B		2A	2A	2A
4.24	Fork - carriage width	b3 mm	1006	1006	1006
4.31	Ground clearance, loaded, under mast	m1 mm	85	94	94
4.32	Ground clearance, centre of wheelbase	m2 mm	90	90	100
4.33	Aisle width for pallets 1,000 x 1,200 crossways	Ast mm	3,352	3,427	3,447
4.34	Aisle width for pallets 800 x 1,200 lengthways	Ast mm	3,495	3,575	3,595
4.35	Turning radius	Wa mm	1,710	1,795	1,810
4.36	Smallest pivot point distance	mm	-	-	-
Performance Data					
5.1	Travel speed, loaded / unloaded	km/h	16 / 17	16 / 17	16 / 17
5.2	Lift speed, loaded / unloaded	mm/s	410 / 600	410 / 600	410 / 600
5.3	Lowering speed, loaded / unloaded	mm/s	500 / 450	500 / 450	500 / 450
5.6	Max. drawbar pull, loaded / unloaded ≥ 2 min	N	15,102 / 14,759	15,190 / 14,710	14,367 / 14,043
5.8	Max. gradient performance, loaded / unloaded ≥ 2 min	%	29.5	27.5	24.5
5.10	Service brake		Hydraulic	Hydraulic	Hydraulic
E - Motor					
6.1	Drive motor rating ≥ 2 60 min	kW	4.7x2	4.7x2	4.7x2
6.2	Pump motor rating at ≥ 3 - 15 %	kW	14.0	14.0	14.0
6.4	Battery voltage, nominal capacity K5	V/Ah	48 / 510	48 / 585	48 / 585
6.5	Battery weight	kg	850	1,030	1,030
	Battery dimensions L / W / H	mm	978 / 545 / 636	978 / 630 / 636	978 / 630 / 636
Other Details					
8.1	Type of drive control		AC	AC	AC

16/18/20B-9

Electric Counterbalance Trucks

MOVING YOU FURTHER

HYUNDAI HEAVY INDUSTRIES



HYUNDAI FORKLIFT
HEAVY INDUSTRIES CO.,LTD.

Head Office (Sales Office)
14th Fl., Hyundai Bldg. 75, Yulgok-ro, Jongno-gu, Seoul 110-796, Korea
TEL (82) (2) 746-4609, 4753 / FAX (82) (2) 746-7444, 7445

Americas Operation : Hyundai Construction Equipment Americas, Inc.
6100 ATLANTIC BOULEVARD NORCROSS GA 30071 U.S.A
TEL (1) 847-678-823-7802 / FAX (1) 847-678-823-7778

Europe Operation : Hyundai Heavy Industries Europe N.V.
VOSSENDAAL 11, 2440 GEEL, BELGIUM
TEL (32) 14-56-2200 / FAX (32) 14-59-3405



PLEASE CONTACT

www.hyundai-ce.com

2013. 12 Rev. 0

HYUNDAI
HEAVY INDUSTRIES CO.,LTD.

Your satisfaction is our priority!

Hyundai introduces a new line of **9-series** battery forklift trucks.

The newly designed 4 wheel counterbalance trucks provide every operator comfortable driving, increased productivity and easy maintenance.

Compact forklift with proven AC technology

Maximum performance

Comfortable operating room

Battery side loading system

Curve control system

Fingertip controlled mini levers available (optional)

Weight indicator (optional)

Safety system that prevents over loading (optional)



Some of the photos may include optional equipment.

High Efficiency & Optimal Performance



Efficient, smooth running and compact design provide you with enhanced performance and highest productivity.

16/18/20B-9



More efficient operating control levers (Optional)

Electronic directional control and secondary horn are mounted to the hydraulic lift lever for quick and precise maneuvering.



Finger tip control levers (Optional)

The finger tip control lever allows more precise control and fatigue-free working. The ergonomically designed armrest can be adjusted up, down, forward and backward for various operator's body type.



Some of the photos may include optional equipment.



Some of the photos may include optional equipment.

Curve control

Curve Control limits travel speed based on turning radius, reducing speed for a smooth, precise turning operation for the driver.



Limit the speed

Designed for compact aisle width and turning radius

Using a dual drive system will minimise aisle width and energy consumption. Plus, the drive units and AC motors intergrated in the front axle provide the operator with extremely improved gradient capacity.



Advanced drive and lift performance with proven durability and low maintenance

The enclosed drive and pump motor with AC technology combine power, high maintenance intervals and excellent durability. The brushless AC motors offer improved efficiency and reduction maintenance cost.



Auto fork leveling system (Optional)

In order to improve productivity the auto fork leveling system will automatically stop the tilt movement when the mast is in a straight position.

Gradeability (MAX)

Model	%
16B-9	29.5
18B-9	27.5
20B-9	24.5

Travel Speed (MAX), unloaded

Model	km / h
16B-9	17
18B-9	17
20B-9	17

Anti roll back system, travel speed and gradeability

Anti Roll-back system offers protection against the machine rolling back on a ramp in combination with exceptional ramp start capabilities.

Advanced Safety

The safely designed driver's space makes your operating more comfortable.

16/18/20B-9



Excellent visibility for safe operation

Optimized lift cylinder arrangement provides operator with wider visibility.

Some of the photos may include optional equipment.



Some of the photos may include optional equipment.

Fork safety features

When the forks are being lowered, a down-control valve maintains the controlled speed. The down-safety valve prevents forks from dropping down in case of sudden damage of hydraulic line.

OPSS(Operator Presence Sensing System)

When the operator is not in the seat all mast and drive movements are impossible.

Lift Lock Tilt Lock Drive Lock



Panoramic mirror

The panoramic mirror expands the driver's view when backing up.

Strong overhead guard

Exceeding EEC and ANSI regulations, the overhead guard offers great protection combined with excellent all around visibility.



Safety lamps & rear reflectors

Halogen headlights and rear LED combination lights offer the driver visibility in all circumstances. Rear reflectors mounted on the counterweight enhance safety for the driver and the application.

Optimised Ergonomics & Fast and Easy Maintenance



An ideal arrangement of components ensures easy access and convenience for maintenance.

16/18/20B-9



Some of the photos may include optional equipment.

Spacious operator cabin

The BT is designed as a small, compact design, yet the operator compartment has ample room for virtually any operator.

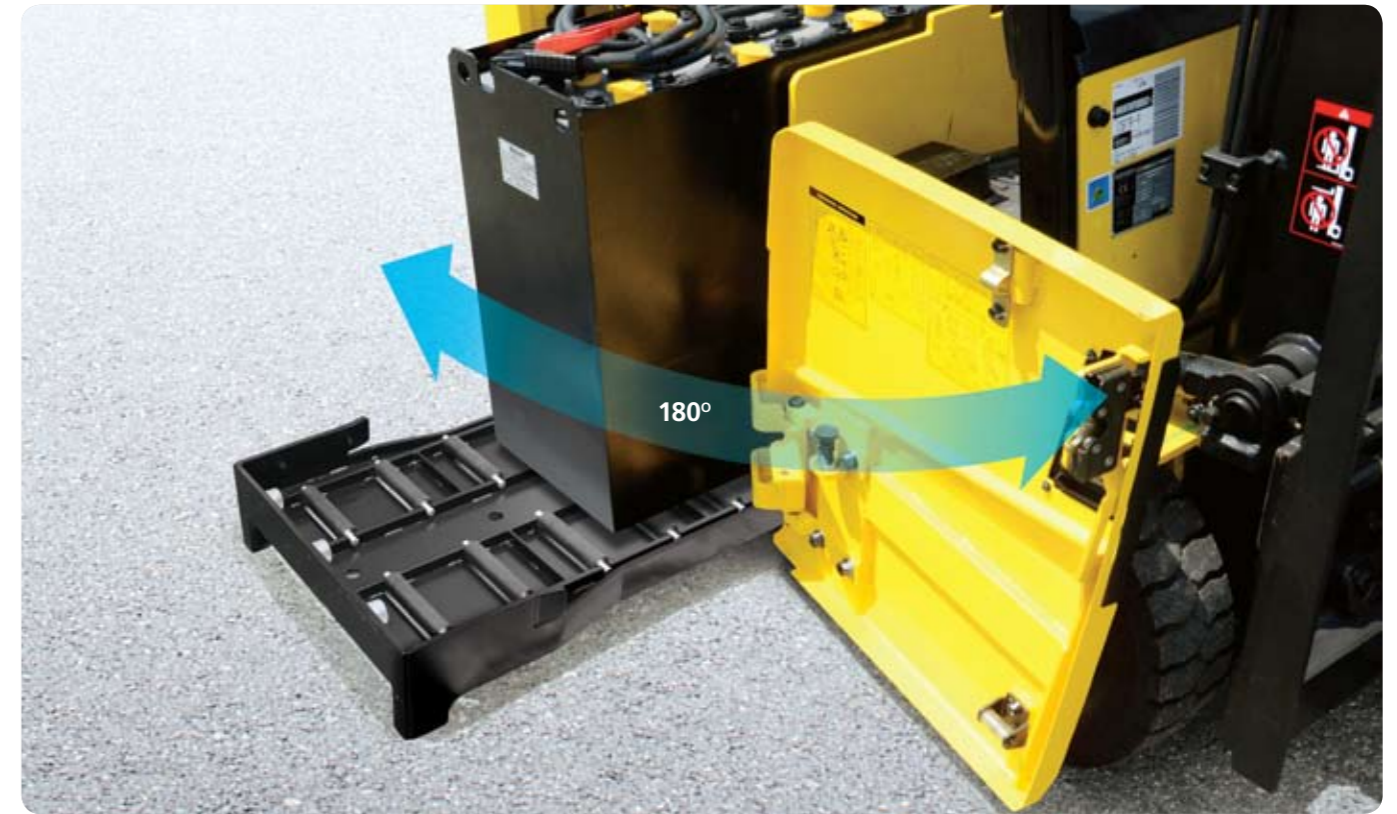

Some of the photos may include optional equipment.

Easy battery replacement

The battery compartment is equipped with a side battery removal assembly for easy removal and replacement.



Optimized pedal position and floor mat

The position of accelerator and throttle have been optimized through human engineering.



Low entrance height

In order to get in and out of the cabin in an easy and safe way the height of the entrance step is only 400mm high.



Adjustable steering wheel

To achieve a comfortable drive position, the angle of the steering column can easily be adjusted through a lever on the right-hand side of the steering column.



Grammer seat (Optional)

An easily adjustable suspension seat, based on a human engineering design, provides greater comfort reducing operator fatigue.



Advanced LCD Monitor

The LCD color monitor with 3.5 inch graphic smart display allows the operator to easily and efficiently control the machine. The monitor provides information about speed & accelerator lever, steer angle & travel direction, battery discharge indicator, hour meter & working mode. The optional load indicator displays the load weight in the monitor. The operator can select various performance modes to meet all working conditions. It is available multi-languages (maximum 11) for operator.



H (High) mode N (Normal) mode E (Economic) mode Turtle mode



Brake oil reservoir with level sensor

The enhanced brake oil reservoir, located in the upper left dash is equipped with an electronic level sensor and easily visible through the monitor.



New 9 Series

16/18/20B-9

Mast Specification (16/18B-9)

Mast Type	Maximum Fork Height (mm)	Overall Height (Lowered) (mm)	Free Lift Height (mm)				Tilt Angle (deg) Fwd / Bwd	Load Capacity without side shift at (500mm LC)(kg)		Load Capacity with side shift at (500mm LC)(kg)		Truck Weight (Unloaded) (kg)			
			With Load Backrest		Without Load Backrest			16B-9	18B-9	16B-9	18B-9	16B-9	18B-9		
			16B-9	18B-9	16B-9	18B-9									
2-Stage Limited free lift	V250	2,525	1,720	1,729	35	35	35	35	5/7	1,600	1,800	1,530	1,730	3,080	3,228
	V270	2,725	1,820	1,829	35	35	35	35	5/7	1,600	1,800	1,530	1,730	3,092	3,240
	V300	3,025	1,970	1,979	35	35	35	35	5/7	1,600	1,800	1,530	1,730	3,112	3,260
	* V330	3,325	2,120	2,129	35	35	35	35	5/7	1,600	1,800	1,530	1,730	3,132	3,280
	V350	3,525	2,220	2,229	35	35	35	35	5/7	1,600	1,800	1,530	1,730	3,145	3,293
	V370	3,725	2,320	2,329	35	35	35	35	5/7	1,600	1,800	1,530	1,730	3,158	3,306
	V400	4,025	2,470	2,479	35	35	35	35	5/7	1,550	1,800	1,490	1,730	3,183	3,330
	V450	4,525	2,820	2,829	35	35	35	35	5/5	1,500	1,750	1,440	1,680	3,250	3,398
	V500	5,025	3,070	3,079	35	35	35	35	5/5	1,400	1,650	1,340	1,590	3,284	3,431
	V550	5,525	3,320	3,329	35	35	35	35	5/5	1,350	1,600	1,300	1,540	3,304	3,451
2-Stage full free lift	VF300	3,025	1,970	1,979	972	981	1534	1543	5/5	1,600	1,800	1,530	1,730	3,151	3,298
	VF330	3,325	2,120	2,129	1122	1131	1684	1693	5/5	1,600	1,800	1,530	1,730	3,172	3,320
	VF350	3,525	2,220	2,229	1222	1231	1784	1793	5/5	1,600	1,800	1,530	1,730	3,187	3,335
3-Stage full free lift	TF/TS370	3,735	1,770	1,779	772	781	1260	1269	5/5	1,550	1,800	1,490	1,730	3,228	3,375
	TF/TS400	4,035	1,870	1,879	872	881	1360	1369	5/5	1,500	1,750	1,440	1,690	3,248	3,395
	TF/TS430	4,335	1,970	1,979	972	981	1460	1469	5/5	1,475	1,725	1,420	1,660	3,267	3,415
	TF/TS450	4,535	2,070	2,079	1072	1081	1560	1569	5/5	1,450	1,700	1,390	1,640	3,287	3,434
	TF/TS470	4,735	2,120	2,129	1122	1131	1610	1619	5/5	1,425	1,650	1,370	1,590	3,297	3,445
	TF/TS500	5,035	2,220	2,229	1222	1231	1710	1719	5/5	1,400	1,600	1,340	1,540	3,317	3,465
	TF/TS550	5,535	2,420	2,429	1422	1431	1910	1919	5/5	1,325	1,500	1,300	1,450	3,357	3,504
	TF/TS600	6,035	2,620	2,629	1622	1631	2110	2119	5/5	1,250	1,350	1,200	1,300	3,420	3,568
	TF/TS650	6,535	2,820	2,829	1822	1831	2310	2319	5/5	1,050	1,300	1,000	1,250	3,465	3,613
	TF/TS700	7,035	3,020	3,029	2022	2031	2510	2519	5/5	900	1,050	860	1,010	3,504	3,651

Load Capacity

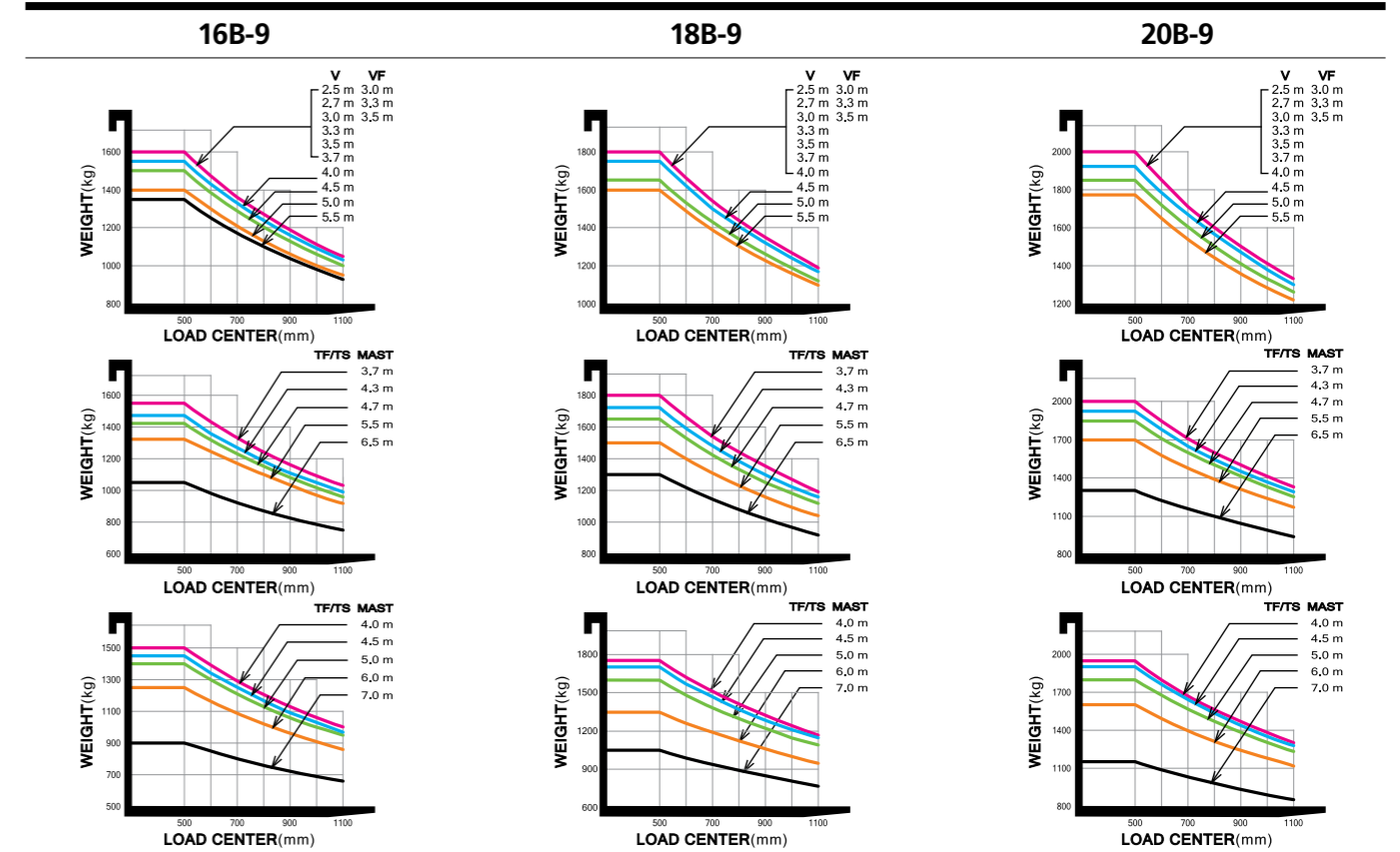

Mast Specification (20B-9)

Mast Type	Maximum Fork Height (mm)	Overall Height (Lowered) (mm)	Free Lift Height (mm)		Tilt Angle (deg) Fwd / Bwd	Load Capacity without side shift at (500mm LC)(kg)		Truck Weight (Unloaded) (kg)	
			With Load Backrest			20B-9	20B-9	20B-9	20B-9
			20B-9	20B-9					
2-Stage Limited free lift	V250	2,530	1,729	40	40	5/7	2,000	1,930	3,428
	V270	2,730	1,829	40	40	5/7	2,000	1,930	3,440
	V300	3,030	1,979	40	40	5/7	2,000	1,930	3,460
	* V330	3,330	2,129	40	40	5/7	2,000	1,930	3,480
	V350	3,530	2,229	40	40	5/7	2,000	1,930	3,493
	V370	3,730	2,329	40	40	5/7	2,000	1,920	3,506
	V400	4,030	2,479	40	40	5/7	2,000	1,920	3,531
	V450	4,530	2,829	40	40	5/5	1,925	1,860	3,598
	V500	5,030	3,079	40	40	5/5	1,850	1,790	3,632
	V550	5,530	3,329	40	40	5/5	1,775	1,710	3,652
2-Stage full free lift	VF300	3,030	1,979	986	1,548	5/5	2,000	1,930	3,499
	VF330	3,330	2,129	1,136	1,698	5/5	2,000	1,930	3,520
	VF350	3,530	2,229	1,236	1,798	5/5	2,000	1,930	3,535
3-Stage full free lift	TF/TS370	3,740	1,779	786	1,274	5/5	2,000	1,930	3,576
	TF/TS400	4,040	1,879	886	1,374	5/5	1,950	1,880	3,596
	TF/TS430	4,340	1,979	986	1,474	5/5	1,925	1,860	3,615
	TF/TS450	4,540	2,079	1,086	1,574	5/5	1,900	1,840	3,635
	TF/TS470	4,740	2,129	1,136	1,624	5/5	1,850	1,790	3,645
	TF/TS500	5,040	2,229	1,236	1,724	5/5	1,800	1,750	3,665
	TF/TS550	5,540	2,429	1,436	1,924	5/5	1,700	1,640	3,705
	TF/TS600	6,040	2,629	1,636	2,124	5/5	1,600	1,540	3,768
	TF/TS650	6,540	2,829	1,836	2,324	5/5	1,300	1,250	3,813
	TF/TS700	7,040	3,029	2,036	2,524	5/5	1,150	1,100	3,852

* Standard
 ※TS-Mast : Wide Visible 3-Stage Full Free Lift Mast with 2 Free Lift Cylinders.

Various Attachments

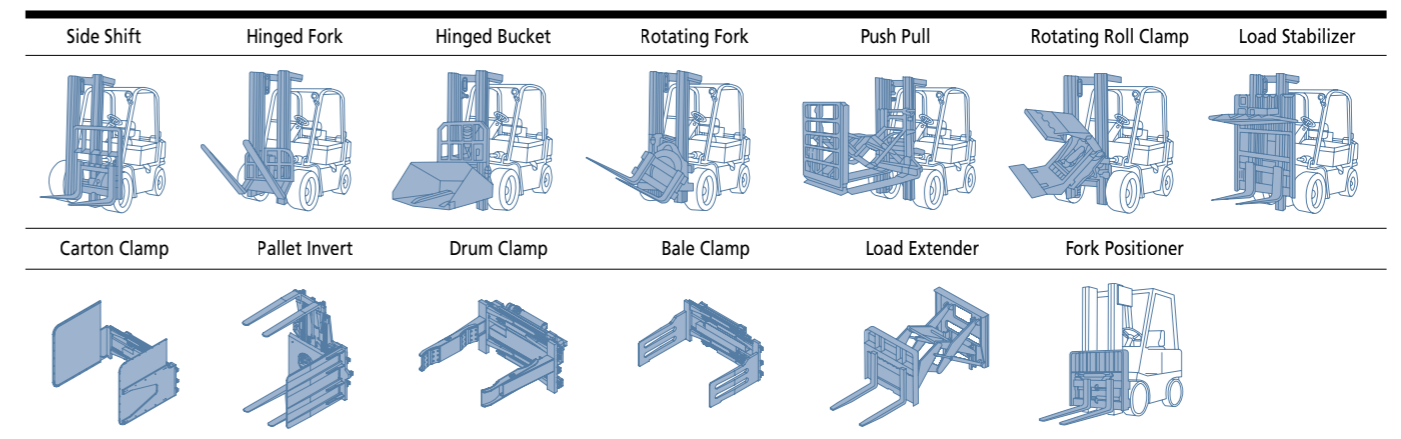

Optional Items

- Fork (mm)
 16 / 18B-9 : 35X100X750, 850, 900(STD), 1050, 1200, 1350, 1500
 20B-9 : 40X100X900(STD), 950, 1000, 1050, 1150, 1200, 1350, 1500, 1600
- Overshoe (mm) : 1300 / 1500 / 1700
- Integral Sideshift
- Tire : SOLID (STD) / Non-marking /
 Wide tire [16B-9 : Front tire (200 / 50-10)]
- Seat : Grammer
- M.C.V : 2-Spool (STD), 3-Spool, 4-Spool
- Auto Fork Leveling
- Beacon Lamp
- Load Indicator
- Work Lamp
- OPSS : Mast
- UL : ES, EE
- Cabin