



Prices effective April 6, 2026

Published April 2026

# Verus® Chairs

HermanMiller list prices shown are in USD.  
For HermanMiller Canadian prices, multiply the USD list price by a factor of 1.20---effective April 2026.

<b>Introduction</b>	<b>page 2</b>
<b>Verus® Chairs</b>	<b>3</b>
Work Chairs	5
Stools	11
Side Chairs	14
<b>Indices</b>	<b>19</b>
By Name	19
By Number	21
<b>Appendices</b>	
20-Day or Less/Assigned Lead-Time Order Information	
Customer's Own Material/Customer's Own Leather Order Information-Seating	
<b>For the latest materials information, refer to the Materials pages on HermanMiller.com.</b>	

# Introduction

## A Note on the Organization of This Book

There are a few signals that will help you understand the organization of this book. Once you know them, you should be able to find your way around easily.

### Like a newspaper, this book is formatted with columns of text and illustrations that run vertically.

Information wraps from one column to the next and continues for as many pages as it needs to.

### Black bars are clues.

A black bar at the top of a page signals the start of information about a product.

This information is divided into two sections, each signaled by a black bar. Product Information includes a description, additional notes, and dimensional drawings. Specification Information, which always begins at the top of a column, includes a series of steps. Each step represents a decision you need to make in order to complete your product number. Steps must be followed sequentially. The number of pages needed to complete information on a product varies; some will be complete in one page; others may fill three or four pages. Just continue going through the steps until you run into the next product, signaled by the black bar at the top of the page.

Black tabs running along the outside edge of the page help you locate what section you are in or what section you want to go to. You can thumb forwards or backwards to find a section; tabs and text appear on both sides of the page.

The additional pages in the back of the book include the appendices and indices. They are signaled by a long black bar running along the outside edge of the page.

### The index is presented two ways.

The first index is in alphabetical order by product name. It can be helpful if you are new to the products and numbering scheme or if you are looking for a type of product, such as work chair or round table.

The second index is by product number. It lists, in alphanumeric order, the base product number, typically a five-digit number.

## General Information

This book is effective April 6, 2026, subject to change without notice. Products may be purchased from authorized Herman Miller dealers who will quote prices upon request. For more information about our products and services or to see a list of dealers, visit [www.HermanMiller.com](http://www.HermanMiller.com).

All prices are list prices. Additional services, such as planning services, design, storage, and installation, are not included and must be added to these prices when the additional services are requested.

Illustrations, specifications, and prices are based on the latest information at the time of publication. The right is reserved to make changes at any time without notice in prices, fabrics, finishes, materials, specifications, and models, and also to discontinue models and finishes.

Dimensions shown in the drawings are engineering drawing dimensions rounded up to the nearest  $\frac{1}{8}$ ". Product is shipped set up or knocked down. Products that include "Shipped knocked down" in the description require some assembly. If this statement does not appear in the description, the product is shipped assembled.

Service problems are normally handled by a Herman Miller authorized dealer. Where this cannot be accomplished on a local level, service problems should be referred to the Customer Care Representative for your region, Herman Miller, Inc., Zeeland, Michigan 49464.

### 20-Day or Less/Assigned Lead-Time Shipments

All products and options in this price book not designated by an Assigned Program icon  will ship in **20 business days or less** after being acknowledged by Herman Miller.

Products and options designated by an  are on the assigned lead-time program and may ship in 20 days, less than 20 days, or more than 20 days from order acknowledgement.

**Work Chairs**

**Stools**

**Side Chairs**





**Product Information**

**Description**

This chair has an upholstered seat with 3 backrest options. The upholstered back option offers an array of textiles with a polymer outer back shell. Interweave 2 is a high-performing suspension material that delivers increased comfort, breathability, built-in sacral support, and total spinal support. The TriFlex™ polymer back is 100% engineered polymer that offers flexible and continuous support including built-in sacral support and meets rigorous cleaning protocols. Interweave 2 suspension back and TriFlex polymer back chairs come standard with passive sacral support and are available with optional adjustable lumbar support with sacral support. The chair has a 5-star base and 2 pneumatic height adjustment options. The back frame/outer shell, arms, arm pads and base finishes are black or mineral. Base is also available in polished aluminum with black or mineral frame.

Tilt options include a semi synchronous with tilt limiter, synchronous with tilt limiter, and a synchronous with tilt limiter and seat angle. All tilts have the option of fixed seat depth or an adjustable seat depth with 2 3/4" range. The tilt limiter allows the user to set tilt range to limit the amount of recline. The synchronous with tilt limiter and seat angle allows the user to set tilt range and select a 5° forward seat angle.

Arm choices include no arms, fixed arms, height-adjustable arms with 4" vertical range, and fully adjustable arms that adjust 4" vertically, 2" front-to-back and 1 1/4" horizontally.

**Notes**

To order ready-to-assemble chair, order (PIA2) separately.

Arms can be removed in the field.

For information on casters and glides, see Casters and Glides in appendices for recommended uses on hard floors and/or carpet.

Customer's Own Material (COM) requires 0.69 yards for seat with Interweave 2 suspension and TriFlex polymer back chairs; 1.19 yards for upholstered seat/back chair; 0.69 yard for upholstered seat chair. See Order Information in appendices.

MicrobeCare™ is an antimicrobial coating that can be applied to a wide variety of Herman Miller Group surfaces to protect products from mold, mildew, algae, and bacteria that cause deterioration, discoloration, odors, and stains.

MicrobeCare™ is a US Environmental Protection Agency (EPA) registered nonpublic health antimicrobial.

MicrobeCare™ is applied to the major touchpoints, including the seat, backrest, arms, armrests, frame and adjustment controls.

**Dimensions**

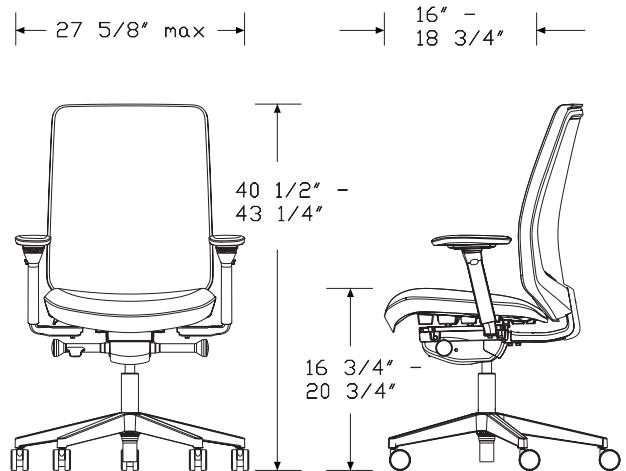

Standard Height Range

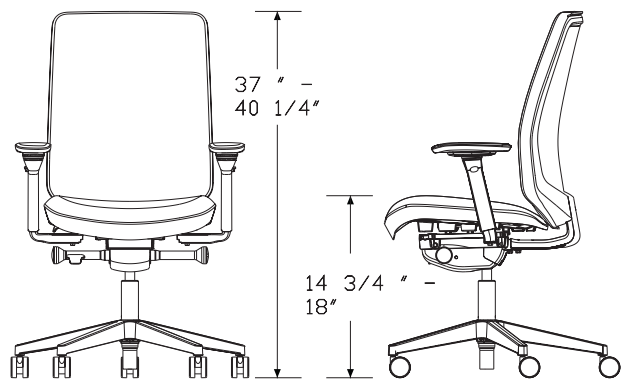

Low Height Range

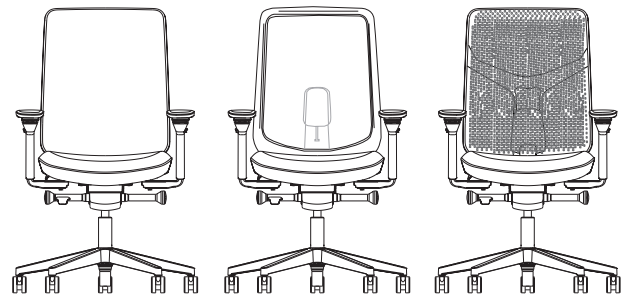

Upholstered

Suspension

Polymer

# Verus® Work Chair, Assembled

continued

Verus® Work Chairs

## Specification Information

### Step 1.

**PIA1**

### Step 2. Back Type

<b>B2</b>	upholstered back	+\$1077
<b>B3</b>	Interweave 2 suspension back	+\$885
<b>B4</b>	TriFlex™ polymer back	+\$830

### Step 3. Height Adjustment

<b>1</b>	low-height range <span style="border: 1px solid black; padding: 0 2px;">A</span>	+\$0
<b>2</b>	standard-height range	+\$0

### Step 4. Tilt

<b>5</b>	semi synchronous with tilt limiter	+\$0
<b>6</b>	synchronous with tilt limiter	+\$52
<b>7</b>	synchronous with tilt limiter and seat angle	+\$99

### Step 5. Arms

<b>N</b>	no arms	+\$0
<b>P</b>	fixed arms	+\$127
<b>H</b>	height-adjustable arms	+\$144
<b>A</b>	fully adjustable arms	+\$241

### Step 6. Seat-Depth Adjustment

<b>F</b>	fixed seat depth	+\$0
<b>A</b>	adjustable seat depth	+\$131

### Step 7. Fire Retardancy

<i>For not fire retardant (*), skip this step.</i>		
	not fire retardant	+\$0

### Step 8. Back Support Option

#### *For Interweave 2 suspension back (B3) or TriFlex™ polymer back (B4)*

<b>N2</b>	no additional support	+\$0
<b>AJ</b>	adjustable lumbar with sacral support	+\$53

#### *For upholstered back (B2)*

<b>N2</b>	no additional support	+\$0
<b>AJ</b>	adjustable lumbar with sacral support	+\$59

### Step 9. Base/Frame Finish

<b>BK</b>	black base/black frame	+\$0
<b>BKV</b>	black base/mineral frame	+\$55
<b>VPR</b>	mineral base/mineral frame	+\$60
<b>68</b>	polished aluminum base/black frame	+\$119
<b>PAM</b>	polished aluminum base/mineral frame	+\$179
<b>MBL</b>	black base/black frame with MicrobeCare™ <span style="border: 1px solid black; padding: 0 2px;">A</span>	+\$70
<b>MBV</b>	black base/mineral frame with MicrobeCare™ <span style="border: 1px solid black; padding: 0 2px;">A</span>	+\$125
<b>MVR</b>	mineral base/mineral frame with MicrobeCare™ <span style="border: 1px solid black; padding: 0 2px;">A</span>	+\$130
<b>M68</b>	polished aluminum base/black frame with MicrobeCare™ <span style="border: 1px solid black; padding: 0 2px;">A</span>	+\$189
<b>MPM</b>	polished aluminum base/mineral frame with MicrobeCare™ <span style="border: 1px solid black; padding: 0 2px;">A</span>	+\$249

### Step 10. Interweave 2 Suspension Material

#### *For Interweave 2 suspension back (B3)*

<b>36501</b>	iceberg	+\$0
<b>36502</b>	poppy	+\$0
<b>36503</b>	beach glass	+\$0
<b>36504</b>	blue grotto	+\$0
<b>36505</b>	slate	+\$0
<b>36506</b>	shale	+\$0

### Step 11. TriFlex™ Polymer Material

#### *For TriFlex™ polymer back (B4)*

<b>98</b>	studio white (CP)	+\$0
<b>DVP</b>	dark mineral	+\$0
<b>DCR</b>	dark carbon	+\$0
<b>PBL</b>	peacock blue	+\$0
<b>RNG</b>	persimmon	+\$0
<b>DJP</b>	jade light	+\$0

### Step 12. Casters

<b>BB</b>	2½" hard caster, black yoke, carpet only	+\$0
<b>GF</b>	2½" high glide, black nylon, hard floors or carpet	+\$25
<b>C7</b>	2½" caster, black yoke, hard floors or carpet	+\$50
<b>C9</b>	2½" braking caster, black yoke, hard floors or carpet	+\$50
<b>SC8</b>	2½" caster, black yoke, hard floors or carpet with quiet roll technology	+\$50

# Verus® Work Chair, Assembled

continued

---

Step 13. Fabric	
<i>For upholstered back (B2)</i>	
Price Category 1	+\$0
Price Category 2	+\$19
Price Category 3	+\$37
Price Category 4	+\$71
Price Category 5	+\$119
Price Category 7	+\$246
Price Category 9	+\$409
Price Category 10	+\$493
Price Category 11	+\$578
Price Category B	+\$54
Price Category C	+\$74
Price Category D	+\$94
Price Category E	+\$113
Price Category F	+\$146
Price Category G	+\$190
Price Category I	+\$271
Price Category J	+\$312

---

Step 14. Seat Fabric	
<i>For Interweave 2 suspension back (B3) or TriFlex™ polymer back (B4)</i>	
Price Category 1	+\$0
Price Category 2	+\$12
Price Category 3	+\$23
Price Category 4	+\$43
Price Category 5	+\$73
Price Category 7	+\$144
Price Category 8	+\$191
Price Category 9	+\$239
Price Category 10	+\$288
Price Category 11	+\$335
Price Category B	+\$34
Price Category C	+\$46
Price Category D	+\$58
Price Category E	+\$70
Price Category F	+\$90
Price Category G	+\$116
Price Category H	+\$142
Price Category I	+\$167
Price Category J	+\$192
Price Category L	+\$241

# Verus® Work Chair, Ready to Assemble

PIA2B



Verus® Work Chairs

## Product Information

### Description

This chair has an upholstered seat with 3 backrest options. The upholstered back option offers an array of textiles with a polymer outer back shell. Interweave 2 is a high-performing suspension material that delivers increased comfort, breathability, built-in sacral support, and total spinal support. The TriFlex™ polymer back is 100% engineered polymer that offers flexible and continuous support including built-in sacral support and meets rigorous cleaning protocols. Interweave 2 suspension back and TriFlex polymer back chairs come standard with passive sacral support and are available with optional adjustable lumbar support with sacral support. The chair has a 5-star base and 2 pneumatic height adjustment options. The back frame/outer shell, arms, arm pads and base finishes are black or mineral. Base is also available in polished aluminum with black or mineral frame.

Tilt options include a semi synchronous with tilt limiter, synchronous with tilt limiter, and a synchronous with tilt limiter and seat angle. All tilts have the option of fixed seat depth or an adjustable seat depth with 2¾" range. The tilt limiter allows the user to set tilt range to limit the amount of recline.

The synchronous with tilt limiter and seat angle allows the user to set tilt range and select a 5° forward seat angle.

Arm choices include no arms, fixed arms, height-adjustable arms with 4" vertical range, and fully adjustable arms that adjust 4" vertically, 2" front-to-back and 1¼" horizontally.

### Notes

To order assembled chair, order (PIA1) separately.

Arms can be removed in the field.

For information on casters and glides, see Casters and Glides in appendices for recommended uses on hard floors and/or carpet.

Customer's Own Material (COM) requires 0.69 yards for seat with Interweave 2 suspension and TriFlex polymer back chairs; 1.19 yards for upholstered seat/back chair; 0.69 yard for upholstered seat chair. See Order Information in appendices.

MicrobeCare™ is an antimicrobial coating that can be applied to a wide variety of Herman Miller Group surfaces to protect products from mold, mildew, algae, and bacteria that cause deterioration, discoloration, odors, and stains.

MicrobeCare™ is a US Environmental Protection Agency (EPA) registered nonpublic health antimicrobial.

MicrobeCare™ is applied to the major touchpoints, including the seat, backrest, arms, armrests, frame and adjustment controls.

## Dimensions

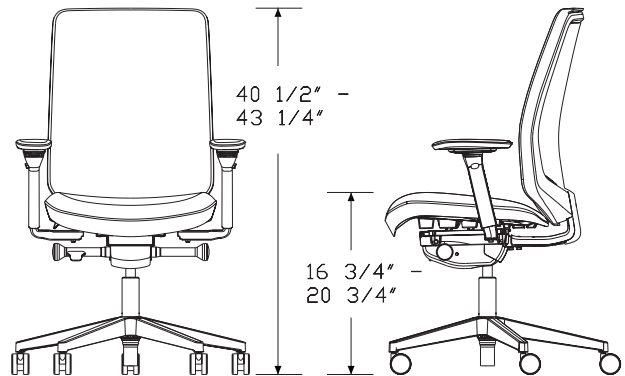

Standard Height Range

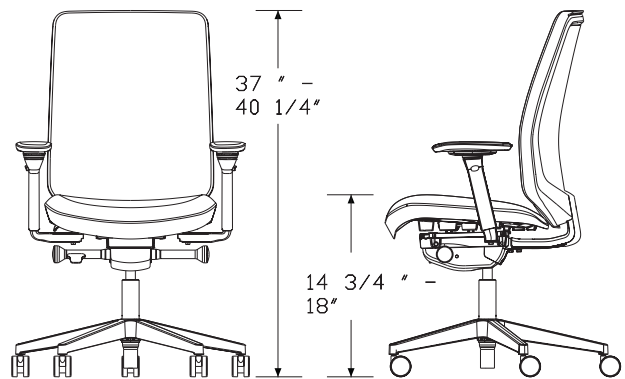

Low Height Range

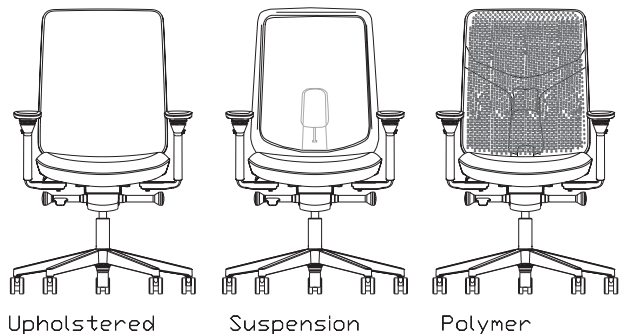

Upholstered

Suspension

Polymer

Verus® Work Chair, Ready to Assemble *continued*

Specification Information		
Step 1.		
<b>PIA2</b>		
Step 2. Back Type		
<b>B2</b>	upholstered back	+\$931
<b>B3</b>	Interweave 2 suspension back	+\$693
<b>B4</b>	TriFlex™ polymer back	+\$643
Step 3. Height Adjustment		
<b>1</b>	low-height range <input type="checkbox"/> A	+\$0
<b>2</b>	standard-height range	+\$0
Step 4. Tilt		
<b>5</b>	semi synchronous with tilt limiter	+\$0
<b>6</b>	synchronous with tilt limiter	+\$45
<b>7</b>	synchronous with tilt limiter and seat angle	+\$99
Step 5. Arms		
<b>N</b>	no arms	+\$0
<b>P</b>	fixed arms	+\$110
<b>H</b>	height-adjustable arms	+\$127
<b>A</b>	fully adjustable arms	+\$211
Step 6. Seat-Depth Adjustment		
<b>F</b>	fixed seat depth	+\$0
<b>A</b>	adjustable seat depth	+\$114
Step 7. Fire Retardancy		
<i>For not fire retardant (*), skip this step.</i>		
	not fire retardant	+\$0
Step 8. Back Support Option		
<i>For Interweave 2 suspension back (B3) or TriFlex™ polymer back (B4)</i>		
<b>N2</b>	no additional support	+\$0
<b>AJ</b>	adjustable lumbar with sacral support	+\$53
<i>For upholstered back (B2)</i>		
<b>N2</b>	no additional support	+\$0
<b>AJ</b>	adjustable lumbar with sacral support	+\$59

Step 9. Base/Frame Finish		
<b>BK</b>	black base/black frame	+\$0
<b>BKV</b>	black base/mineral frame	+\$55
<b>VPR</b>	mineral base/mineral frame	+\$60
<b>68</b>	polished aluminum base/black frame	+\$119
<b>PAM</b>	polished aluminum base/mineral frame	+\$179
<b>MBL</b>	black base/black frame with MicrobeCare™ <input type="checkbox"/> A	+\$70
<b>MBV</b>	black base/mineral frame with MicrobeCare™ <input type="checkbox"/> A	+\$125
<b>MVR</b>	mineral base/mineral frame with MicrobeCare™ <input type="checkbox"/> A	+\$130
<b>M68</b>	polished aluminum base/black frame with MicrobeCare™ <input type="checkbox"/> A	+\$189
<b>MPM</b>	polished aluminum base/mineral frame with MicrobeCare™ <input type="checkbox"/> A	+\$249
Step 10. Interweave 2 Suspension Material		
<i>For Interweave 2 suspension back (B3)</i>		
<b>36501</b>	iceberg	+\$0
<b>36502</b>	poppy	+\$0
<b>36503</b>	beach glass	+\$0
<b>36504</b>	blue grotto	+\$0
<b>36505</b>	slate	+\$0
<b>36506</b>	shale	+\$0
Step 11. TriFlex™ Polymer Material		
<i>For TriFlex™ polymer back (B4)</i>		
<b>98</b>	studio white (CP)	+\$0
<b>DVP</b>	dark mineral	+\$0
<b>DCR</b>	dark carbon	+\$0
<b>PBL</b>	peacock blue	+\$0
<b>RNG</b>	persimmon	+\$0
<b>DJP</b>	jade light	+\$0
Step 12. Casters		
<b>BB</b>	2½" hard caster, black yoke, carpet only	+\$0
<b>GF</b>	2½" high glide, black nylon, hard floors or carpet	+\$25
<b>C7</b>	2½" caster, black yoke, hard floors or carpet	+\$50
<b>C9</b>	2½" braking caster, black yoke, hard floors or carpet	+\$50
<b>SC8</b>	2½" caster, black yoke, hard floors or carpet with quiet roll technology	+\$50

Verus® Work Chair, Ready to Assemble *continued*

Verus® Work Chairs

Step 13. Fabric	
<i>For upholstered back (B2)</i>	
Price Category 7	+\$246
Price Category 11	+\$578
Price Category 1	+\$0
Price Category 2	+\$19
Price Category 3	+\$37
Price Category 4	+\$71
Price Category 5	+\$119
Price Category 9	+\$409
Price Category 10	+\$493
Price Category B	+\$54
Price Category C	+\$74
Price Category D	+\$94
Price Category E	+\$113
Price Category F	+\$146
Price Category G	+\$190
Price Category I	+\$271
Price Category J	+\$312

Step 14. Seat Fabric	
<i>For Interweave 2 suspension back (B3) or TriFlex™ polymer back (B4)</i>	
Price Category 11	+\$335
Price Category 1	+\$0
Price Category 2	+\$12
Price Category 3	+\$23
Price Category 4	+\$43
Price Category 5	+\$73
Price Category 7	+\$144
Price Category 8	+\$191
Price Category 9	+\$239
Price Category 10	+\$288
Price Category B	+\$34
Price Category C	+\$46
Price Category D	+\$58
Price Category E	+\$70
Price Category F	+\$90
Price Category G	+\$116
Price Category H	+\$142
Price Category I	+\$167
Price Category J	+\$192
Price Category L	+\$241

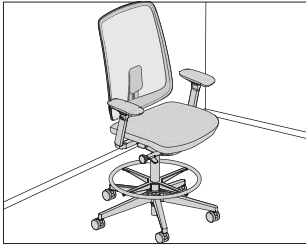

**Product Information**

**Description**

This stool has an upholstered seat with 3 backrest options. The upholstered back option offers an array of textiles with a polymer outer back shell. Interweave 2 is a high-performing suspension material that delivers increased comfort, breathability, built-in sacral support, and total spinal support. The TriFlex™ polymer back is 100% engineered polymer that offers flexible and continuous support including built-in sacral support and meets rigorous cleaning protocols. Interweave 2 suspension back and TriFlex polymer back stools come standard with passive sacral support and are available with optional adjustable lumbar support with sacral support. The stool has a 5-star base and pneumatic height adjustment. The back shell, arms, arm pads and tilt cover finishes are black or mineral. A 20" diameter footrest adjusts 4 1/2" in height. Footrest finish is trivalent chrome. Column and ring support are black. Tilt options include height adjustable and synchronous with tilt limiter. Height adjustable option does not recline. Synchronous with tilt limiter option allows the user to set tilt range to limit the amount of recline. Both tilts have a fixed seat depth. Arm choices include no arms, fixed arms, height-adjustable arms with 4" vertical range, and fully adjustable arms that adjust 4" vertically, 2" front-to-back and 1 1/4" horizontally.

**Notes**

Arms can be removed in the field.  
 Stool ships fully assembled.  
 For information on casters and glides, see Casters and Glides in appendices for recommended uses on hard floors and/or carpet.  
 Customer's Own Material (COM) requires 0.69 yards for seat with Interweave 2 suspension and TriFlex polymer back stools; 1.19 yards for upholstered seat/back stool; 0.69 yard for upholstered seat stool. See Order Information in appendices.  
 MicrobeCare™ is an antimicrobial coating that can be applied to a wide variety of Herman Miller Group surfaces to protect products from mold, mildew, algae, and bacteria that cause deterioration, discoloration, odors, and stains.  
 MicrobeCare™ is a US Environmental Protection Agency (EPA) registered nonpublic health antimicrobial.  
 MicrobeCare™ is applied to the major touchpoints, including the seat, backrest, arms, armrests, frame and adjustment controls.

**Dimensions**

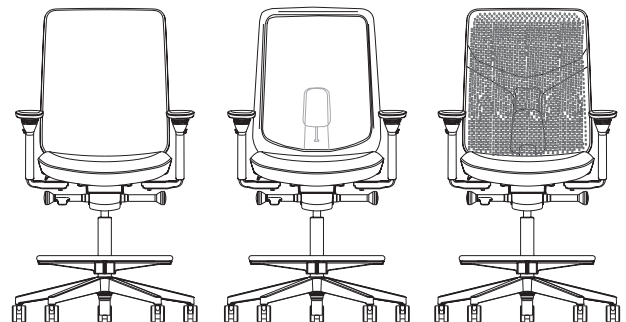
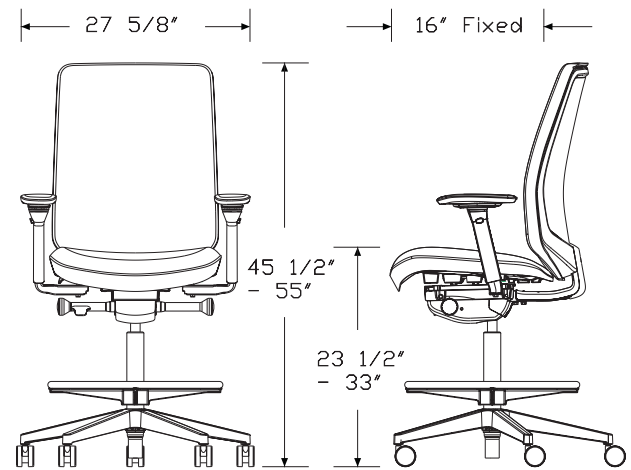

Upholstered

Suspension

Polymer

Specification Information		
Step 1.		
<b>PIA7</b>		
Step 2. Back Type		
<b>B2</b>	upholstered back	+\$1247
<b>B3</b>	Interweave 2 suspension back	+\$1056
<b>B4</b>	TriFlex™ polymer back	+\$1002
Step 3. Height Adjustment		
<b>1</b>	standard stool height	+\$0
Step 4. Tilt		
<b>5</b>	height adjustable	+\$0
<b>6</b>	synchronous with tilt limiter	+\$99
Step 5. Arms		
<b>N</b>	no arms	+\$0
<b>P</b>	fixed arms	+\$127
<b>H</b>	height-adjustable arms	+\$144
<b>A</b>	fully adjustable arms	+\$241
Step 6. Seat-Depth Adjustment		
<b>F</b>	fixed seat depth	+\$0
Step 7. Fire Retardancy		
<i>For not fire retardant (*), skip this step.</i>		
	not fire retardant	+\$0
Step 8. Back Support Option		
<i>For Interweave 2 suspension back (B3) or TriFlex™ polymer back (B4)</i>		
<b>N2</b>	no additional support	+\$0
<b>AJ</b>	adjustable lumbar with sacral support	+\$53
<i>For upholstered back (B2)</i>		
<b>N2</b>	no additional support	+\$0
<b>AJ</b>	adjustable lumbar with sacral support	+\$59

Step 9. Base/Frame Finish		
<b>BK</b>	black base/black frame	+\$0
<b>BKV</b>	black base/mineral frame	+\$55
<b>VPR</b>	mineral base/mineral frame	+\$60
<b>68</b>	polished aluminum base/black frame	+\$119
<b>PAM</b>	polished aluminum base/mineral frame	+\$179
<b>MBL</b>	black base/black frame with MicrobeCare™ <b>A</b>	+\$70
<b>MBV</b>	black base/mineral frame with MicrobeCare™ <b>A</b>	+\$125
<b>MVR</b>	mineral base/mineral frame with MicrobeCare™ <b>A</b>	+\$130
<b>M68</b>	polished aluminum base/black frame with MicrobeCare™ <b>A</b>	+\$189
<b>MPM</b>	polished aluminum base/mineral frame with MicrobeCare™ <b>A</b>	+\$249
Step 10. Interweave 2 Suspension Material		
<i>For Interweave 2 suspension back (B3)</i>		
<b>36501</b>	iceberg	+\$0
<b>36502</b>	poppy	+\$0
<b>36503</b>	beach glass	+\$0
<b>36504</b>	blue grotto	+\$0
<b>36505</b>	slate	+\$0
<b>36506</b>	shale	+\$0
Step 11. TriFlex™ Polymer Material		
<i>For TriFlex™ polymer back (B4)</i>		
<b>98</b>	studio white (CP)	+\$0
<b>DVP</b>	dark mineral	+\$0
<b>DCR</b>	dark carbon	+\$0
<b>PBL</b>	peacock blue	+\$0
<b>RNG</b>	persimmon	+\$0
<b>DJP</b>	jade light	+\$0
Step 12. Casters		
<b>BB</b>	2½" hard caster, black yoke, carpet only	+\$0
<b>GF</b>	2½" high glide, black nylon, hard floors or carpet	+\$25
<b>C7</b>	2½" caster, black yoke, hard floors or carpet	+\$50
<b>C9</b>	2½" braking caster, black yoke, hard floors or carpet	+\$50
<b>SC8</b>	2½" caster, black yoke, hard floors or carpet with quiet roll technology	+\$50

Step 13. Fabric	
<i>For upholstered back (B2)</i>	
Price Category 7	+\$246
Price Category 11	+\$578
Price Category 1	+\$0
Price Category 2	+\$19
Price Category 3	+\$37
Price Category 4	+\$71
Price Category 5	+\$119
Price Category 9	+\$409
Price Category 10	+\$493
Price Category B	+\$54
Price Category C	+\$74
Price Category D	+\$94
Price Category E	+\$113
Price Category F	+\$146
Price Category G	+\$190
Price Category I	+\$271
Price Category J	+\$312

Step 14. Seat Fabric	
<i>For Interweave 2 suspension back (B3) or TriFlex™ polymer back (B4)</i>	
Price Category 11	+\$335
Price Category 1	+\$0
Price Category 2	+\$12
Price Category 3	+\$23
Price Category 4	+\$43
Price Category 5	+\$73
Price Category 7	+\$144
Price Category 8	+\$191
Price Category 9	+\$239
Price Category 10	+\$288
Price Category B	+\$34
Price Category C	+\$46
Price Category D	+\$58
Price Category E	+\$70
Price Category F	+\$90
Price Category G	+\$116
Price Category H	+\$142
Price Category I	+\$167
Price Category J	+\$192
Price Category L	+\$241

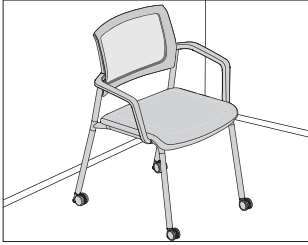

Verus® Side Chairs

**Product Information**

**Description**

This side chair has an upholstered seat and an option of an Interweave 2 suspension back or upholstered back with a polymer outer back shell. It has a 4-leg base with casters or glides and is available with fixed arms or without arms. Polymer back shell and arm finishes are black or mineral. Leg finish choices are black, satin carbon, satin aluminum and trivalent chrome.

All models of this side chair with 4-leg base can be stacked 4 chairs high on the floor. When armless model is stacked 4 chairs high the measurements are 19 1/4"W×30 1/2"D; for model with arms measurements are 25"W×30 1/2"D.

**Notes**

TriFlex™ polymer back material not offered.

For information on casters and glides, see Casters and Glides in appendices for recommended uses on hard floors and/or carpet.

Customer's Own Material (COM) requires 0.75 yard for upholstered seat and back; 0.72 yard for upholstered seat only. See Order Information in appendices.

MicrobeCare™ is an antimicrobial coating that can be applied to a wide variety of Herman Miller Group surfaces to protect products from mold, mildew, algae, and bacteria that cause deterioration, discoloration, odors, and stains.

MicrobeCare™ is a US Environmental Protection Agency (EPA) registered nonpublic health antimicrobial.

MicrobeCare™ is applied to the major touchpoints, including the seat, backrest, arms, armrests, and frame.

**Dimensions**

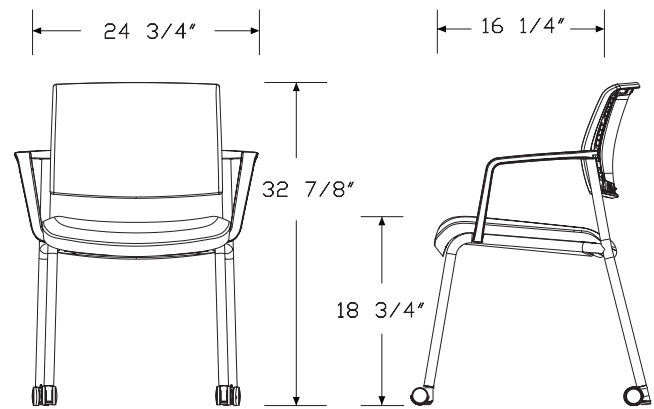

Upholstered

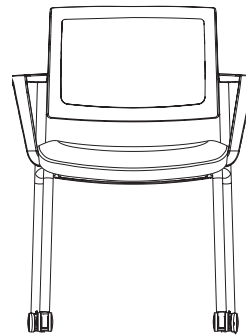

Suspension

# Verus® Side Chair, 4-Leg Base

continued

## Specification Information

### Step 1.

**PIA4S**

### Step 2. Base

**1** 4-leg base +\$668

### Step 3. Back Style

**S** Interweave 2 suspension back +\$0  
**U** upholstered back +\$110

### Step 4. Arms

**N** no arms +\$0  
**P** fixed arms +\$67

### Step 5. Fire Retardancy

*For not fire retardant (\*), skip this step.*

not fire retardant +\$0

### Step 6. Frame Color

**BK** black +\$0  
**VPR** mineral +\$20  
**MBL** black with MicrobeCare™  A +\$50  
**MVR** mineral with MicrobeCare™  A +\$70

### Step 7. Leg Finish

**BK** black +\$0  
**SNC** satin carbon +\$20  
**SNA** satin aluminum +\$40  
**47** trivalent chrome +\$190

### Step 8. Interweave 2 Suspension Material

*For Interweave 2 suspension back (S)*

**36501** iceberg +\$0  
**36502** poppy +\$0  
**36503** beach glass +\$0  
**36504** blue grotto +\$0  
**36505** slate +\$0  
**36506** shale +\$0

### Step 9. Casters

**G4** glide, carpet only +\$0  
**GL** glide, hard floors only +\$10  
**U4** hard wheel caster, carpet only +\$30  
**U5** soft wheel caster, carpet or hard floors +\$30

### Step 10. Fabric

*For upholstered back (U)*

Price Category 7 +\$246  
 Price Category 11 +\$578  
 Price Category 1 +\$0  
 Price Category 2 +\$20  
 Price Category 3 +\$41  
 Price Category 4 +\$77  
 Price Category 5 +\$128  
 Price Category 9 +\$258  
 Price Category 10 +\$493  
 Price Category B +\$59  
 Price Category C +\$82  
 Price Category D +\$102  
 Price Category E +\$124  
 Price Category F +\$160  
 Price Category G +\$208  
 Price Category H +\$252  
 Price Category I +\$295  
 Price Category J +\$312

### Step 11. Seat Fabric

*For Interweave 2 suspension back (S)*

Price Category 1 +\$0  
 Price Category 2 +\$12  
 Price Category 3 +\$23  
 Price Category 4 +\$43  
 Price Category 5 +\$73  
 Price Category 7 +\$144  
 Price Category 8 +\$191  
 Price Category 9 +\$258  
 Price Category 10 +\$288  
 Price Category 11 +\$335  
 Price Category B +\$34  
 Price Category C +\$46  
 Price Category D +\$58  
 Price Category E +\$70  
 Price Category F +\$90  
 Price Category G +\$116  
 Price Category H +\$142  
 Price Category I +\$167  
 Price Category J +\$192  
 Price Category L +\$241

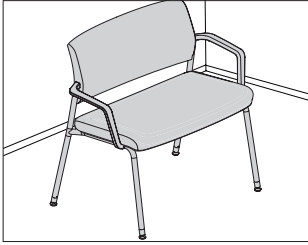

Verus® Side Chairs

**Product Information**

**Description**

This side chair has an upholstered seat and an upholstered back with a polymer outer back shell. It has a 4-leg base with glides only and fixed arms. The angled design of the legs prevents the chair back from damaging walls. Polymer back shell and arms are black. Leg finish choices are black, satin carbon and satin aluminum.

**Notes**

Interweave 2 suspension and TriFlex™ polymer back materials are not offered.

Chair does not stack.

Customer's Own Material (COM) requires 1.25 yards for chair with upholstered seat and back. See Order Information in appendices.

For information on casters and glides, see Casters and Glides in appendices for recommended uses on hard floors and/or carpet.

**Dimensions**

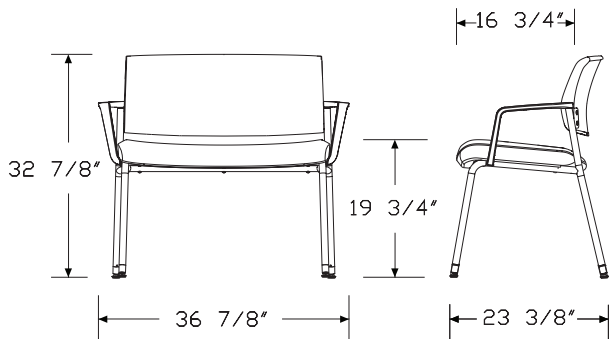

**Specification Information**

**Step 1.**

**PIA4P**

**Step 2. Base**

**1** 4-leg base +\$1528

**Step 3. Back Style**

**U** upholstered back +\$0

**Step 4. Arms**

**P** fixed arms +\$0

**Step 5. Fire Retardancy**

*For not fire retardant (\*), skip this step.*

not fire retardant +\$0

**Step 6. Frame Color**

**BK** black +\$0

**VPR** mineral +\$40

**Step 7. Leg Finish**

**BK** black +\$0

**SNC** satin carbon +\$20

**SNA** satin aluminum +\$40

**Step 8. Glides**

**G4** glide, carpet only +\$0

**GL** glide, hard floors only +\$10

## Verus® Plus Side Chair, 4-Leg Base

*continued*

---

Step 9. Fabric	
Price Category 11	+\$607
Price Category 1	+\$0
Price Category 2	+\$42
Price Category 3	+\$53
Price Category 4	+\$58
Price Category 5	+\$121
Price Category 7	+\$259
Price Category 8	+\$342
Price Category 9	+\$430
Price Category 10	+\$511
Price Category B	+\$79
Price Category C	+\$98
Price Category D	+\$98
Price Category E	+\$138
Price Category F	+\$172
Price Category G	+\$216
Price Category I	+\$317
Price Category J	+\$364



## Index by Product Name

<b>Verus® Chairs</b>	
Verus® Plus Side Chair, 4-Leg Base	page(s) 16
Verus® Side Chair, 4-Leg Base	14
Verus® Work Chair, Assembled	5
Verus® Work Chair, Ready to Assemble	8
Verus® Work Stool	11



## Index by Product Number



PIA1B	Verus® Work Chair, Assembled	page(s) 5
PIA2B	Verus® Work Chair, Ready to Assemble	8
PIA4P	Verus® Plus Side Chair, 4-Leg Base	16
PIA4S	Verus® Side Chair, 4-Leg Base	14
PIA7B	Verus® Work Stool	11



## 20-Day or Less/Assigned Lead-Time Order Information

### 20-Day or Less and Assigned Lead-Time Programs

20-day or less and assigned lead-time products are designed for established Herman Miller dealers with pre-approved credit.

Products are distributed from multiple manufacturing facilities across the United States. All products and options not designated by an Assigned Lead-Time icon  will ship in 20 business days or less after being acknowledged by Herman Miller. Products and options designated by an  are on the assigned lead-time program and will ship in 20 days, less than 20 days, or more than 20 days from order acknowledgement.

### Ordering Procedure

Please place orders through Order Manager. If this is not available to you, place orders through mail or fax. Verbal purchase orders will not be accepted.

Order Entry fax number for Meridian®

Filing and Storage: (616) 846 9236.

Order Entry fax number for all other products:

(616) 654 3085.

For more information, contact your Customer Care representative at: (866) 854 3048 ext 3400.

### Shipments and Delivery

Per Herman Miller Terms and Conditions.

### Changes and Cancellation

Per Herman Miller Terms and Conditions.



# Casters and Glides

▲	<b>WARNING</b>	▲
Depending on the floor surface, chair may unexpectedly roll away from user when entering or exiting the chair, possibly leading to unexpected injury. Please refer to descriptions of floor types when selecting casters.		

**32 Caster**

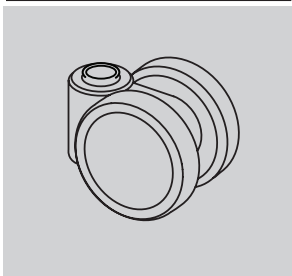

1 7/8-inch-diameter hard double-wheel caster; black nylon wheels and yoke; for use on carpet only

Applicable on:  
Sayl® Chairs

**BB Caster**

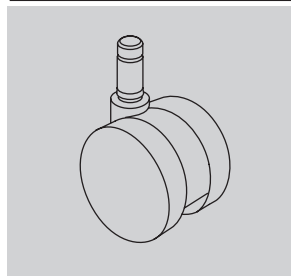

2 1/2-inch-diameter hard double-wheel caster; black nylon wheels and yoke; for use on carpet only

Applicable on:  
Asari Chair by Herman Miller™  
New Aeron® Chairs  
Caper® Chairs  
Embody® Chairs  
Fuld Nesting Chairs  
Lino™ Chairs  
Sayl Chairs  
Mirra® 2 Chairs, Verus™ Chairs

**BSC Caster**

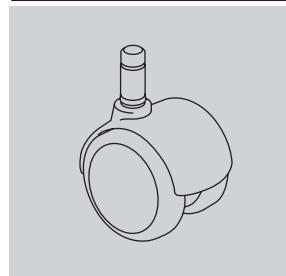

2-inch-diameter double-wheel caster; black nylon wheels and hood; soft polyurethane tread; for use on hard floors or carpet

Applicable on:  
Eames® Aluminum Group  
Eames Executive Chairs  
Eames Soft Pad Group  
Eames Task Chairs

**C9 Caster**

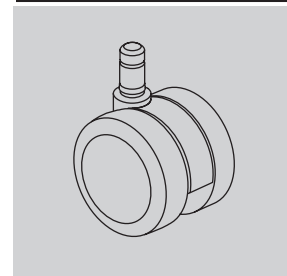

2 1/2-inch-diameter double-wheel caster; black nylon wheels and yoke; soft polyurethane tread; internal brake; for use on hard floors or carpet

Applicable on:  
Caper Chairs  
Embody Chairs  
Lino Chairs  
Mirra 2 Chairs  
Sayl Chairs  
Setu® Chairs  
Verus Chairs

**49 Caster**

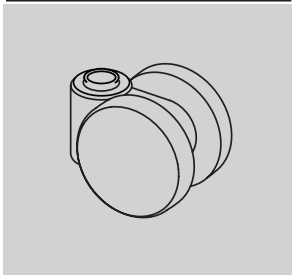

1 7/8-inch-diameter soft double-wheel caster; black nylon wheels and yoke; for use on hard floors or carpet

Applicable on:  
Sayl Chairs

**BKS Caster**

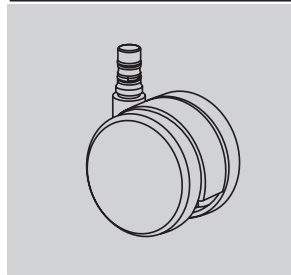

2 1/2-inch-diameter hard double-wheel caster; black yoke; quiet roll technology; for use on carpet only

Applicable on:  
Cosm™ Chairs

**C7 Caster**

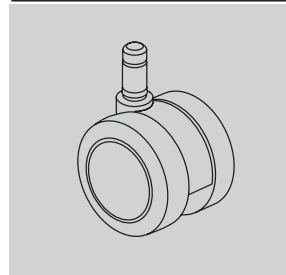

2 1/2-inch-diameter double-wheel caster; black nylon wheels and yoke; soft polyurethane tread; for use on hard floors or carpet

Applicable on:  
Asari Chair by Herman Miller™  
New Aeron Chairs  
Caper Chairs  
Embody Chairs  
Fuld Nesting Chairs  
Lino Chairs                      Sayl Chairs  
Mirra 2 Chairs                  Verus Chairs

**CSQ Caster**

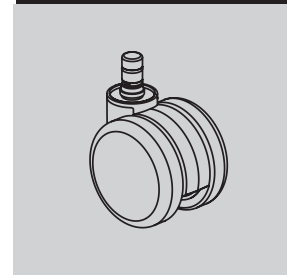

2 1/2-inch-diameter double-wheel caster; color-matched nylon wheels and yoke; soft polyurethane tread; for use on hard floors or carpet

Applicable on:  
Zeph® Chairs

# Casters and Glides

continued

**DC1 Caster**

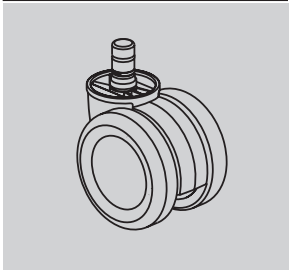

2 1/2-inch-diameter double-wheel braking caster; black nylon wheels and yoke; for use on hard floors or carpet; quiet roll technology

Applicable on:

New Aeron Chairs

**H9 Caster**

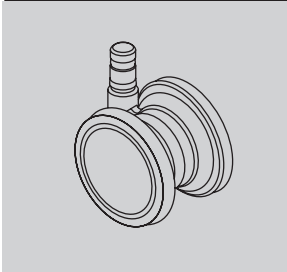

2 1/2-inch-diameter double-wheel caster; clear polycarbonate wheels; nylon yoke; soft polyurethane tread; for use on carpet only

Applicable on:

Embody Chairs

**MD Caster**

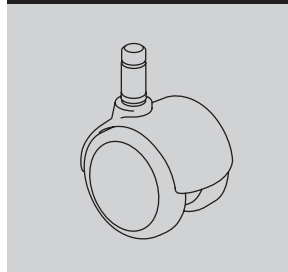

2-inch-diameter double-wheel caster; black nylon wheels with integral chrome hood; soft polyurethane tread; for use on hard floors or carpet

Applicable on:

Eames® Aluminum Group  
Eames Executive Chairs  
Eames Soft Pad Group  
Eames Task Chairs

**OC Caster**



2 1/2-inch-diameter double-wheel medium roll-resistant caster; black nylon wheels and yoke; soft polyurethane tread; for use on hard floors or carpet; quiet roll technology

Applicable on:

Cosm Chairs  
Fuld Nesting Chairs  
Setu Chairs

**DS Caster**

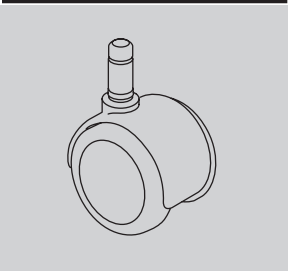

2-inch-diameter soft double-wheel braking caster; black nylon wheels and hood; for use on hard floors only

Applicable on:

Aside® Chairs  
Caper Chairs

**HCC Caster**



2 1/2-inch-diameter double-wheel low roll resistance caster; black nylon yoke; for use on hard floors or carpet

Applicable on:

Setu Chairs

**O2 Caster**

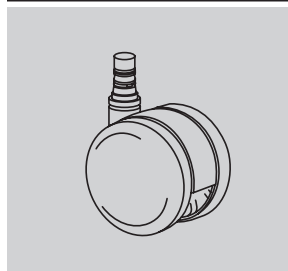

2 1/2-inch-diameter double-wheel caster; nylon wheels and yoke; soft polyurethane tread; quiet roll technology; for use on floors or carpet

Applicable on:

Cosm Chairs

**SC8 Caster**

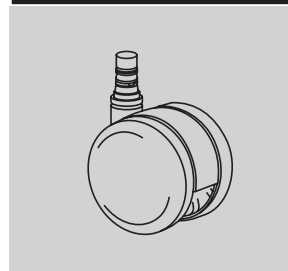

2 1/2-inch-diameter double-wheel caster; black nylon wheels and yoke; soft polyurethane tread; quiet roll technology; for use on hard floors or carpet

Applicable on:

Cosm Chairs  
Fuld Nesting Chairs  
Lino Chairs  
Mirra 2 Chairs  
Verus Chairs

# Casters and Glides

continued

**U4 Caster**

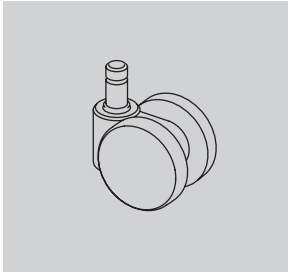

1<sup>7</sup>/<sub>8</sub>-inch-diameter hard double-wheel caster; black nylon wheels and yoke; for use on carpet only

Applicable on:  
Aside Chairs  
Verus Chairs

**UD Caster**

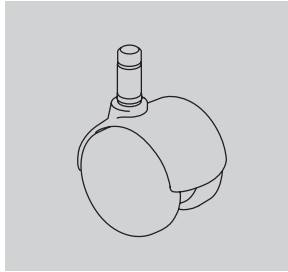

2-inch-diameter hard double-wheel caster; black nylon wheels with painted hood; for use on carpet only

Applicable on:  
Eames® Aluminum Group  
Eames Executive Chairs  
Eames Soft Pad Group  
Eames Task Chairs

**16 Glide**

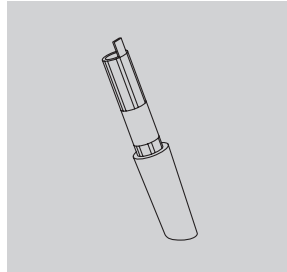

(Front glide shown)  
2<sup>1</sup>/<sub>8</sub>-inch-high glide; black or fog acetal; for use on carpet only

Applicable on:  
Sayl Chairs

**FGG Glide**

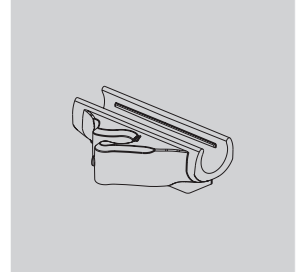

1/2-inch-high ganging glide; black ABS plastic with black felt bottom; for use on resilient flooring

Applicable on:  
Pronta Stacking Chairs

**U5 Caster**

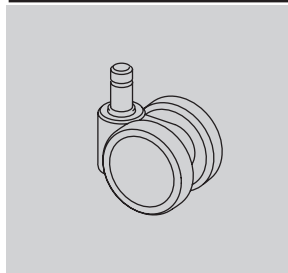

1<sup>7</sup>/<sub>8</sub>-inch-diameter soft double-wheel caster; black nylon wheels and yoke; for use on hard floors or carpet

Applicable on:  
Aside Chairs  
Caper Chairs  
Verus Chairs

**VD Caster**

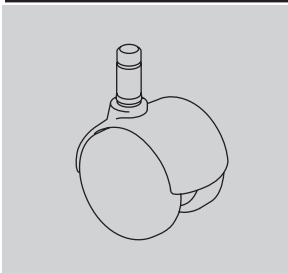

2-inch-diameter hard double-wheel caster; black nylon wheels with integral chrome hood; for use on carpet only

Applicable on:  
Eames Aluminum Group  
Eames Executive Chairs  
Eames Soft Pad Group  
Eames Task Chairs

**69 Glide**

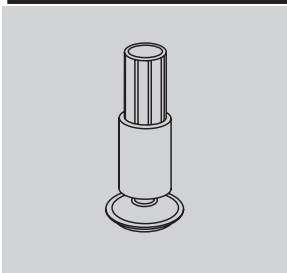

(Front glide shown)  
2<sup>1</sup>/<sub>8</sub>-inch-high glide; black glass-filled nylon stem; steel-plated swivel foot with Floor Saver Glide™ insert; for use on hard floors only

Applicable on:  
Sayl Chairs

**FTG Glide**

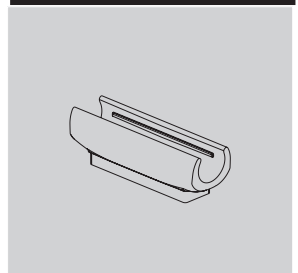

1/2-inch-high glide; black ABS plastic with black felt bottom; for use on resilient flooring

Applicable on:  
Pronta Stacking Chairs

# Casters and Glides

continued

**G4 Glide**

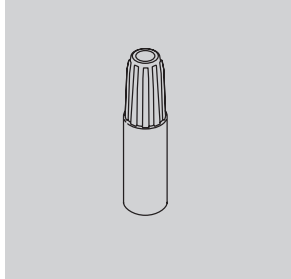

1<sup>7</sup>/<sub>8</sub>-inch-high glide; black acetal; for use on carpet only

Applicable on:

Verus Chairs

**GF Glide**

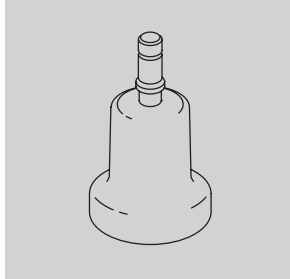

2<sup>1</sup>/<sub>2</sub>-inch-high glide; black nylon; for use on hard floors or carpet

Applicable on:

New Aeron Chairs  
Caper Chairs  
Cosm Chairs  
Lino Chairs  
Mirra 2 Chairs  
Sayl Chairs  
Verus Chairs

**GG Glide**

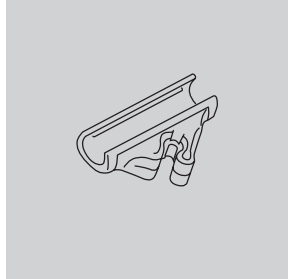

1<sup>1</sup>/<sub>2</sub>-inch-high ganging glide; clear polycarbonate; for use on hard floors or carpet

Applicable on:

Pronta Stacking Chairs

**GLN Glide**

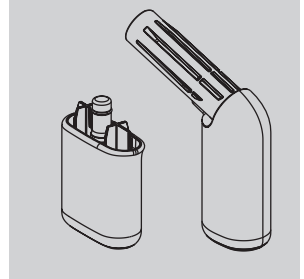

Acetal glide; for use on carpet only

Applicable on:

Fuld Nesting Chairs

**GD Glide**

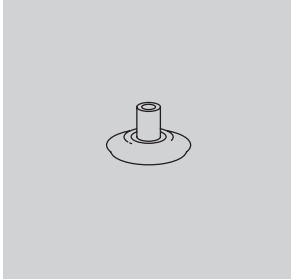

1<sup>1</sup>/<sub>2</sub>-inch-diameter glide; 1/2 inch in height; black nylon; for use on hard floors or carpet

Applicable on:

Eames Aluminum Group  
Eames Executive Chairs  
Eames Soft Pad Group  
Eames Task Chairs

**GFG Glide**



Floor Saver Glide™ insert; for use on hard floors only

Applicable on:

Zeph Chairs

**GL Glide**

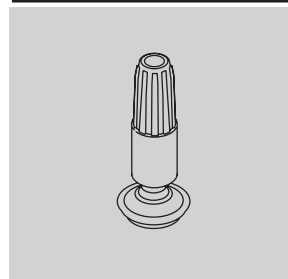

1<sup>7</sup>/<sub>8</sub>-inch-high glide; black nylon stem; steel-plated swivel foot with Floor Saver Glide™ insert; for use on hard floors only

Applicable on:

Verus chairs

**GNB Glide**

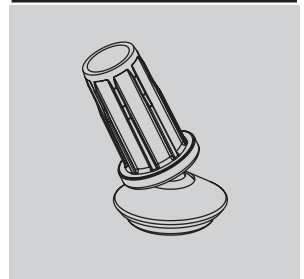

Swivel glide; nylon base; for use on carpet only

Applicable on:

Zeph Chairs

# Casters and Glides

continued

**HG Glide**



1/2-inch-high glide; black nylon glide with stainless-steel insert; for use on hard floors or carpet

Applicable on:  
Aside Chairs

**SG Glide (for Pronta)**

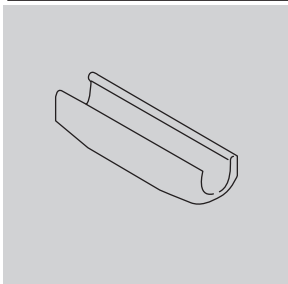

1/2-inch-high glide; clear polycarbonate; for use on hard floors or carpet

Applicable on:  
Pronta Stacking Chairs

**XS Glide**

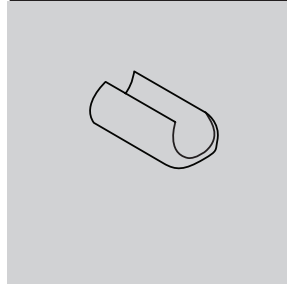

1/8-inch-high glide; polycarbonate in black, fog, clear, and studio white finishes; for use on hard floors or carpet

Applicable on:  
Sayl Chairs

**YX Glide**

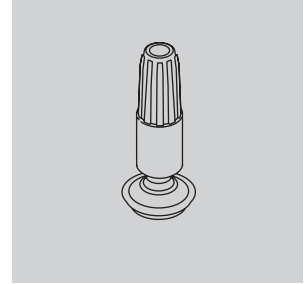

1 7/8-inch-high glide; black nylon stem; steel-plated swivel foot with Floor Saver Glide™ insert; for use on hard floors only

Applicable on:  
Caper Chairs

**SG Glide (for Aside)**

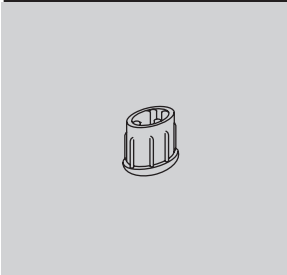

1/2-inch-high glide; black nylon; for use on carpet only

Applicable on:  
Aside Chairs

**X8 Glide**

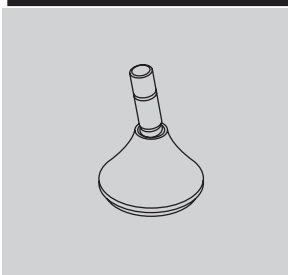

Glide; low profile; for use on hard floors or carpet

Applicable on:  
Setu Chairs

**Y7 Glide**

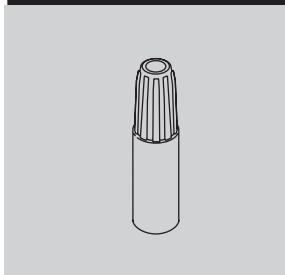

1 7/8-inch-high glide; black acetal; for use on carpet only

Applicable on:  
Caper Chairs



# Customer's Own Material/ Customer's Own Leather Order Information — Seating

## Packaging

Packaging varies according to individual product. A surcharge may be added for special packaging requests. Contact Customer Care for specific information.

## Customer's Own Material/Customer's Own Leather

### Program Overview

The Customer's Own Material (COM) and Customer's Own Leather (COL) program gives you the option of using textiles other than those listed. Herman Miller will test textiles for application to Herman Miller products and will process orders for those with approved COM/COL textiles only. COM/COL are assigned lead-time textiles.

Omni lists an overview of fabrics and leathers that have been tested and indicates whether or not they were approved for application to Herman Miller products.

Specific information on the terms and conditions, testing, approval, and ordering process for COM/COL is listed below. Questions about the COM/COL program and requests for assistance may be directed to your COM representative at:

(616) 654 3400

(866) 854 3048 ext 6543400

### Customer's Own Material/Customer's Own Leather Warranty

Herman Miller does not warrant COM/COL textiles. COM/COL textiles are tested for application only; they are not tested for performance. The Herman Miller warranty does apply to the underlying products.

Suppliers of COM/COL textiles are responsible for color consistency within commercial tolerances, UV stability, and resistance to soiling and perspiration.

### Customer's Own Material/Customer's Own Leather Pricing

COM is a Category 1 fabric. There are no application charges for COM fabrics. COL is a Category 7 textile; refer to prices on specific products to determine the application charge.

Ordering and payment for COM/COL textile yardage are the responsibility of the customer and the textile supplier.

If desired, Herman Miller will purchase COM textiles directly from Maharam, Camira, C.F. Stinson, Guilford of Maine, Luna Textiles, Momentum Textiles and Ultrafabrics to simplify ordering and shipment. For this service, refer to the Supplier Connection program.

## Textile Approval

1. Select a COM textile and a Herman Miller product.
2. If your textile does not show as tested in Omni, submit a request. You will be required to select a specific color of the textile and feature of the product to test, i.e., seat, back, etc.
3. Herman Miller will notify you of approval or disapproval within 4 days from receipt of the test yardage.

## Ordering Products with COM/COL

1. Refer to the specific products to determine the yardage required for COM/COL textiles.  
*Note: Additional yardage may be needed due to the unique characteristics of a textile.*
2. Obtain the COM ID# in Omni. If the color you are ordering does not have a COM ID# assigned, click "Create ID".
3. Enter your order on Order Manager in Omni.
4. Upon receipt of your purchase order, Herman Miller will send you a PO acknowledgment.
5. Arrangements must be made for the textiles to be shipped from the supplier to Herman Miller for application to the seating products. Textiles must be tagged with the assigned identification number and the roll yardage quantity. See Omni for shipping procedures and current shipping addresses or contact a COM representative at (616) 654 3400 or (866) 854 3048 ext 6543400.

Products will be scheduled for production when COM/COL textiles are received at Herman Miller. Standard lead times in effect at that time will apply.

*Note: If textiles are to be purchased directly by Herman Miller through the Supplier Connection program, Herman Miller will handle the ordering and shipping process and will schedule your order for production upon receipt of your purchase order (dependent on textile availability). Refer to the Supplier Connection program for more information.*

# Customer's Own Material/ Customer's Own Leather Order Information — Seating

continued

## Supplier Connection

### Program Overview

The Supplier Connection program is a service offered by Herman Miller to purchase approved COM textiles directly from Maharam, Camira, C.F. Stinson, Guilford of Maine, Luna Textiles, Momentum Textiles and Ultrafabrics. When you select a textile through this program, Herman Miller will facilitate the ordering, scheduling, and shipment of the textile directly with the supplier.

Suppliers included in the Supplier Connection program keep an active inventory of textiles that are pre-approved for application to Herman Miller products. Pre-approval applies only to the suitability of a textile for manufacturing and application to a Herman Miller product. Omni provides an overview of fabrics that have been tested and indicates whether or not they were approved for application to Herman Miller products.

Specific information on the terms and conditions, testing, approval, and ordering process for the Supplier Connection program is listed below. Questions and requests for assistance may be directed to your COM representative at:  
(616) 654 3400  
(866) 854 3048 ext 6543400

### Supplier Connection Warranty

Textiles purchased by Herman Miller through the Supplier Connection program are COM and are not warranted by Herman Miller. COM textiles are tested for application only; they are not tested for performance. The Herman Miller warranty does apply to the underlying products.

Suppliers of COM textiles are responsible for color consistency within commercial tolerances, UV stability, and resistance to soiling and perspiration.

### Supplier Connection Pricing

Textiles purchased by Herman Miller through the Supplier Connection program are COM. COM is a Category 1 fabric. There are no application charges for COM fabrics.

Payment for textiles purchased by Herman Miller through the Supplier Connection program is the responsibility of the customer or dealer. Herman Miller will invoice the order at a total product cost based on the supplier's price published at the time of the order.

### Textile Approval

1. Select a COM textile and a Herman Miller product.
2. If your textile does not show as tested in Omni, submit a request. You will be required to select a specific color of the textile and feature of the product to test, i.e., seat, back, etc.
3. Herman Miller will notify you of approval or disapproval within 4 days from receipt of the test yardage.

### Ordering Products with Supplier Connection COM

1. Identify and include the following information on your purchase order:
  - Product number and option
  - Herman Miller's COM identification number
2. Enter your order on Order Manager in Omni.
3. Upon receipt of the purchase order, Herman Miller will process your order and send you a PO acknowledgment. Herman Miller will determine the yardage required to produce your product and will order and schedule for delivery the required textile. Standard lead times in effect at the time the textile is allocated at the supplier will apply to products ordered through this program.



For more information about our products and services or to see a list of dealers, please visit us at [HermanMiller.com](http://HermanMiller.com) or call (800) 851 1196.

© 2026 Herman Miller, Inc., Zeeland, Michigan

#### Distribution Rights

Working together since 1956, Herman Miller and Vitra are the authentic sources of designs by Charles and Ray Eames, Alexander Girard, and George Nelson. All the designs shown in this book are protected by law. Herman Miller has obtained all rights to make and sell these designs. Also, Herman Miller holds exclusive worldwide manufacturing and distribution rights for these products with the following exceptions:

Charles and Ray Eames, George Nelson, and Alexander Girard—Worldwide distribution rights for furniture in all areas except Europe and the Middle East. For those areas, please contact Vitra.

Isamu Noguchi—Worldwide distribution rights for the Noguchi Rudder Table. Distribution rights for the Noguchi Table in North America and Central America only. For all other areas, please contact Vitra.

Magis—Exclusive distribution rights in the US and Canada. For all other areas, please contact Magis.

© **HermanMiller**, ●, 3D Intelligent, 8Z Pellicle, AO, Action Office, Aeron, Aside, Bubble Lamps, Canvas Office Landscape, Caper, Celle, Cosm, Co/Struc, Daisyone, Distil, Eames, Eco-Dematerialized, Embody, Envelop, Ethospace, Exclave, Fine-Tune, FlexFront, Flo, Formcoat, Formwork, Ground Cloth, Intent, Kinemat, Layout Studio, Lino, Live Unframed, Living Office, Maharam, Meridian, Mirra, Motia, Nelson, Pari, Pellicle, Perspectives, Plex, PostureFit, PostureFit SL, Public Office Landscape, Sayl, Setu, Striad, Tu, Ubi, Verus, Wishbone, Y-Tower and Zeph are among the registered trademarks of Herman Miller, Inc., and its owned subsidiaries.

™ About Face, AireWeave, Airia, Ambit, Asari Chair by HermanMiller, Backfit, Bubbletack, Burdick Group, Butterfly Back, Canvas Vista, Cellular Suspension, Commend, Compass, Connect, DOT, Duracare, Durawrap, EnhancedAccess, Everywhere, Flex-Edge, Flute, Harmonic, Headway, Herman Miller Select, Hopsak 2, Iota, Keyless Entry, Latitude, Logic Mini, Logic Power Access Solutions, Lyris, Lyris 2, Made-to-Measure Storage, Mora, Multiscrim, Nevi, OE1, OE1 Workspace Collection, Overlay, Pixelated Support, Pronta, Renew, Sense, Soft Pad, Stackable, Stackable Storage, Swoop, Thrive, Tone, TriFlex, Twist and Wireframe are among the trademarks of Herman Miller, Inc., and its owned subsidiaries.

SM Herman Miller Options is among the service marks of Herman Miller, Inc.

AAP™ is a trademark of Extron Electronics.

Alexander Girard® is a registered trademark of The Alexander Girard Estate.

Chemsurf® is a registered trademark of Wilsonart International.

Corian® is a registered trademark of E. I. du Pont de Nemours and Company Corporation.

Crypton® is a registered trademark of Crypton, Inc.

DACRON® is a registered trademark of INVISTA S.a r.l.

Danzer® is a registered trademark of Danzer Holding AG.

Decora® is a registered trademark of Leviton Manufacturing Co., Inc.

Edelman® Leather is a registered trademark of Edelman Leather, Inc.

Extron® is a registered trademark of RGB Systems, Inc.

FENIX NTM® is a registered trademark of Arpa Industriale S.p.A.

FLEXNET™ is a trademark of Milliken & Company.

Floor Saver Glide® is a registered trademark of Carpin Manufacturing, Inc.

Forest Stewardship Council® is a registered trademark of the Forest Stewardship Council A.C. (FSC). We are FSC® certified (FSC® C102895).

FSC® is a registered trademark of the Forest Stewardship Council A.C. (FSC).

Geiger® is a registered trademark, and Bumper™, Saiba™, and Ward Bennett™ are trademarks, of Geiger International.

Hang-It-All® is a registered trademark of Lucia Eames Demetrios, d.b.a. Eames Office.

Holophane® is a registered trademark of Holophane.

Ingeo™ is a trademark of Cargill Dow LLC.

iPad® and Mac mini® are registered trademarks of Apple Inc.

Leviton® is a registered trademark of Leviton Manufacturing Co., Inc.

LifeSize® is a registered trademark of LifeSize Communications, Inc.

Lisocore® is a registered trademark of Pyrus Panels GmbH.

Logitech G® is a registered trademark of Logitech International S.A.

Magis®, Bombo®, and Me Too® are registered trademarks of Magis S.p.A.

MicrobeCare™ is a trademark of Parasol Medical LLC.

Microsoft® and Natural® Keyboard are registered trademarks of Microsoft Corporation.

Noguchi® and the Noguchi table configuration (trade dress) are registered trademarks, and Rudder Table™ is a trademark, of The Isamu Noguchi Foundation and Garden Museum.

Place Textiles® is a registered trademark of Place Textiles.

Sunbrella® is a registered trademark of Glen Raven, Inc.

SuperSeat™ is a trademark of Dahti Seating, a division of ITW.