



ABS-300

Precision Attenuator for Hard X-Rays

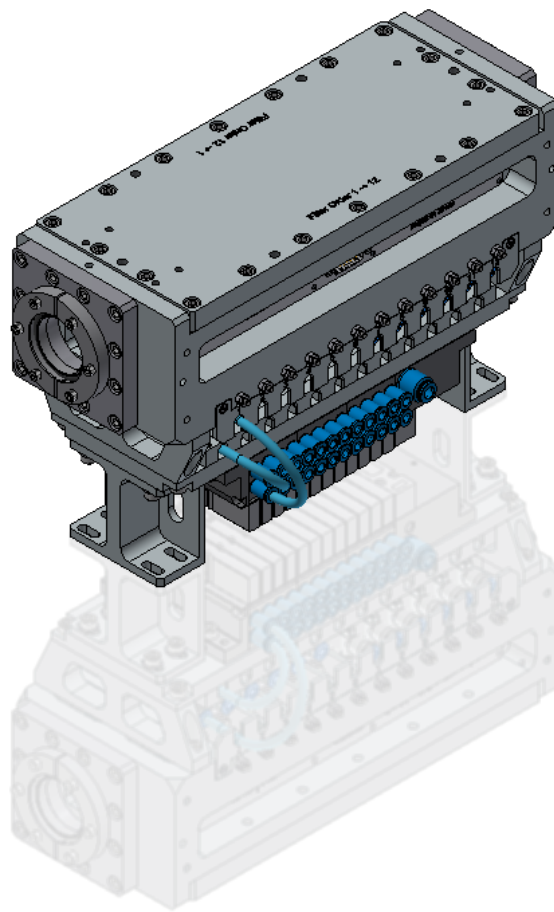



Photo of the ABS-300 Filter System

Device Overview

AVS|US has licensed and is offering a Precision Attenuator for Hard X-Rays (ABS-300) that was developed over many years at the synchrotron radiation source PETRA III at DESY. This system provides the ability for scientists to reduce the incident x-ray flux to any desired value.

For many applications at hard x-ray beamlines at lab sources and synchrotron radiation sources the detected intensity spans more than six orders of magnitude. An integrated flux of more than one million counts per second is far too much for most of the detectors in use, which can even be severely damaged on saturation. For this reason, x-ray beamlines are equipped with so-called attenuators/absorbers which reduce the beam load on the detector by blocking the x-ray beam with a semi-transparent material (called filter or foil).

The ABS-300 precision attenuator is of the filter bank rather than wheel type. This High Vacuum X-Ray Attenuator contains 12 frames with 21 mm x 15 mm apertures which carry the *attenuation* foils. Each of these frames moves on a ball-bearing slideway assembly. The motion is actuated by pneumatic pistons outside the vacuum which move the frames using a magnetic field through the chamber floor. This means that no vacuum feed-through is used for this design and that the absorber moves promptly and quickly. The pneumatic pistons are controlled by a manifold of electric valves which controlled from a Windows PC using the provided electrical controller.

The provided filters may easily be swapped for filters of other thicknesses and metals as needed by the researcher. In the presented setup 12 different filters (made from ultrapure aluminum, titanium, and copper) can be moved into the beam and small reed-sensors detect success of the movement.

ABS-300 Features

- 12 Foil carriers, with a 20 mm x 15 mm effective aperture
- Foil carriers can be loaded with other items of similar size such as photodiodes
- Foils can easily be exchanged for others of different metal and thickness
- Low power electrically controlled
- Usable in a wide energy range (Type 1: 5-30 keV; Type 2: 2.5-20 keV)
- High-Vacuum Capability (1e-7 mbar)
- Stiff structure and minimal vibration
- Reliable detection of the actual position of the slides (in or out of the beam)
- TCP/IP Controller Interface to PC from a PLC
- The filters are moved from the outside using magnets without venting, bellows, or feedthroughs
- NW40 or DN40 optional flange adaptors to interface to the beam tube

Flange Interface Options

Three options are available for flanges: DN40 (“Conflat”) flanges, NW40 (formerly KF or QF) flanges, and adapters for Blake Industries beam path tube. These attach to the ends of the chamber using a mounting plate and an O-ring seal. The following images show the three flange options installed: DN40 on the left NW40 in the middle, and Blake Industries tube on the right.

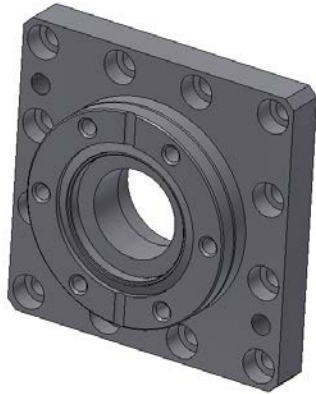

DN40



NW40

Filter Foil Options

There are three foil options installed type 1, type 2, and ‘no foil’ options. Custom foil installation is available.

Absorber 5-30KeV (type1)

Thicknesses t of the foils

Number	Theoretical t Al (μm)	Theoretical t Ti (μm)	Theoretical t Cu (μm)	Actual Combination
1	25			Al25
2	50			Al50
3	100			Al100
4	200			2 x Al100
5	400			Al250 & Al100 & Al25
6	800			Al500 & Al250 & Al50
7	1600	234.1		Ti125 & 2 x Ti80 & Al250 & Al10
8	3200	468.2		3 x Ti125 & Ti50 & Al250 & Al50
9	6400	936.4		7 x Ti125 & Al250 & Al50 & Al25
10	12800	1873	403.4	4 x Cu100 & Al100
11	25600	3746	806.8	2 x Cu250 & 3 x Cu100 & 2 x Al100
12	51200	7491	1614	Cu1000 & 2 x Cu250 & Cu100 & Al250 & 2 x Al100

Absorber 25.-20KeV (type2, nonlinear)

Thicknesses t of the foils

Theoretical Theoretical Theoretical Actual Combination (purity of Al6: 99.0%)

Number	t Al (μm)	t Ti (μm)	t Cu (μm)	All figures given in μm
1	6			Al6
2	12			2 x Al6
3	24			Al25
4	48			Al50
5	106			Al100 & Al6
6	230			2 x Al100 & Al25 & Al6
7	500			Al500
8	1070			2 x Al150 & Al50 & Al25
9	2300	327.6		2 x Ti125 & Al250 & Al50 & Al25
10	5000	712.1		4 x Ti25 & Ti50 & Al250
11	10700	1524	341.8	3 x Cu100 & Cu25 & 2 x Al250 & Al25
12	23500	3347	750.	3 x Cu250

Exchanging Foils

The foils can easily be exchanged for others of the same length and width dimensions to fit the needs of the experiment at hand. After replacing foils, as the top plate is placed onto the device, care must be taken to ensure that the frames do not hit the side walls or edges of the opening or damage to the frames may result.

The below diagrams provided below illustrate a single frame assembly with all its pieces. The diagram shows an assembly with four layers of foil to provide the proper thickness.

The parts shown in the right-hand diagram are:

1. M2x4 Stainless Steel socket head cap screws
2. The aluminium frame
3. The foils or crystals
4. Aluminium 'window' clamp bar

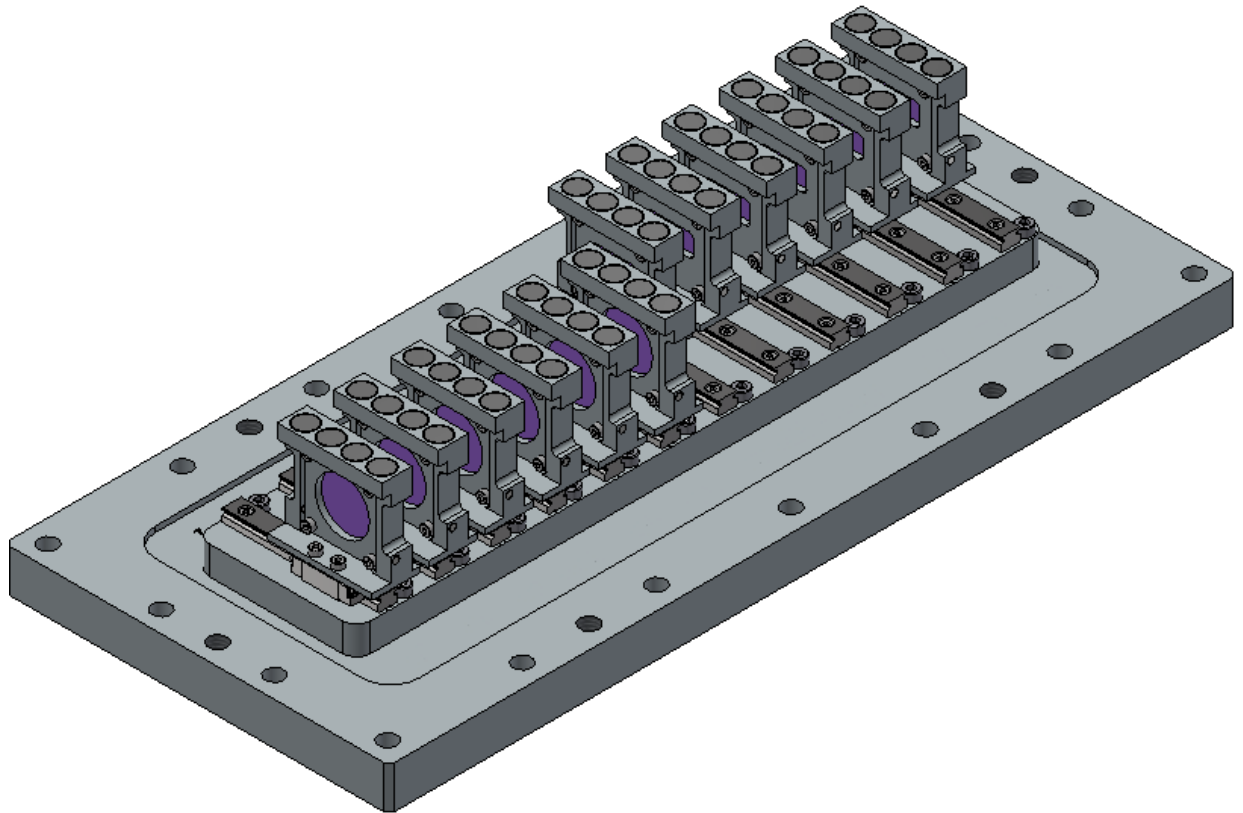
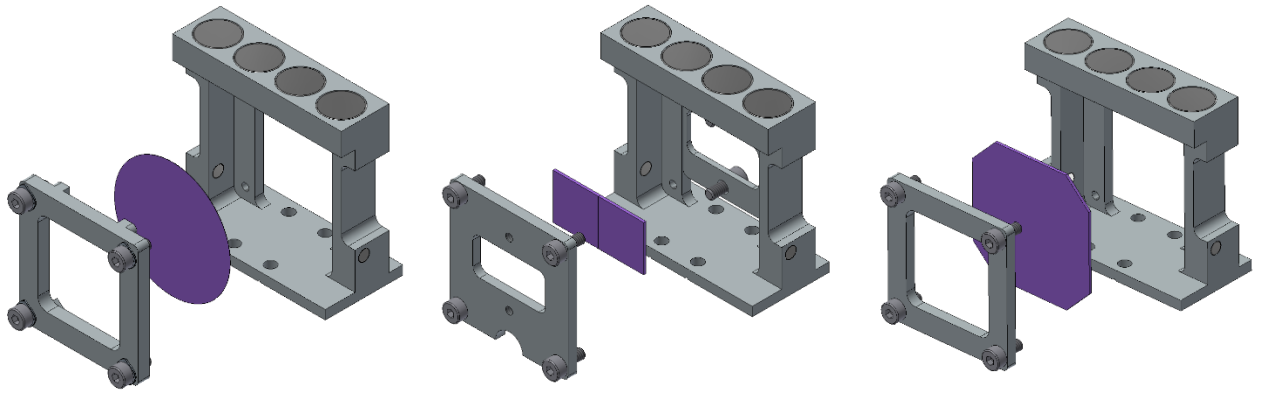

ABS-300 CONTROLLER

The ABS-300 precision attenuator is controlled using a PLC but could be operated with other controllers. The PLC as a slave to the PC and use the MODBUS protocol to interface over the Ethernet port. This particular application uses two relay inputs and one relay output. Each relay module has a total of sixteen terminals. The user PC will function as the master and can communicate using the MODBUS ports or the software which is freely sent with the ABS-300 Controller. However, any external 24V-toggle signal can be used to drive the single pneumatic actuators, and the reed-sensors are mechanical switches which can be read by TTL logics.



ABS-300 SOFTWARE

The ABS-CR-01 Controller will come with control software on a CD. This should automatically install on the user's PC. The ABS-300 software is a simple but effective way to move the filters in and out of the beam. Below is a summary layout.

ABS-300 Controller
Controller IP Address: 172.16.17.1

ABS-300

Switch Tab | Filter Tab | Total Absorption: 12.00

In Beam Magnet Sensors			Out of Beam Magnet Sensors		
1			1		
2			2		
3			3		
4			4		
5			5		
6			6		
7			7		
8			8		
9			9		
10			10		
11			11		
12			12		

ABS-CR-01
Filter Control Software
Version: 1.1.0.18

EXIT

Filter Tab

Total absorption currently in the beam

Manual move filter

Magnet sensors detect the 'Out of Beam'

Magnet sensors detect the 'In Beam' status

ORDERING INFORMATION:

The attenuator can be ordered with different foil configurations, please use the codes provided below when ordering. Please call or e-mail to ask about customization if your application requires it.

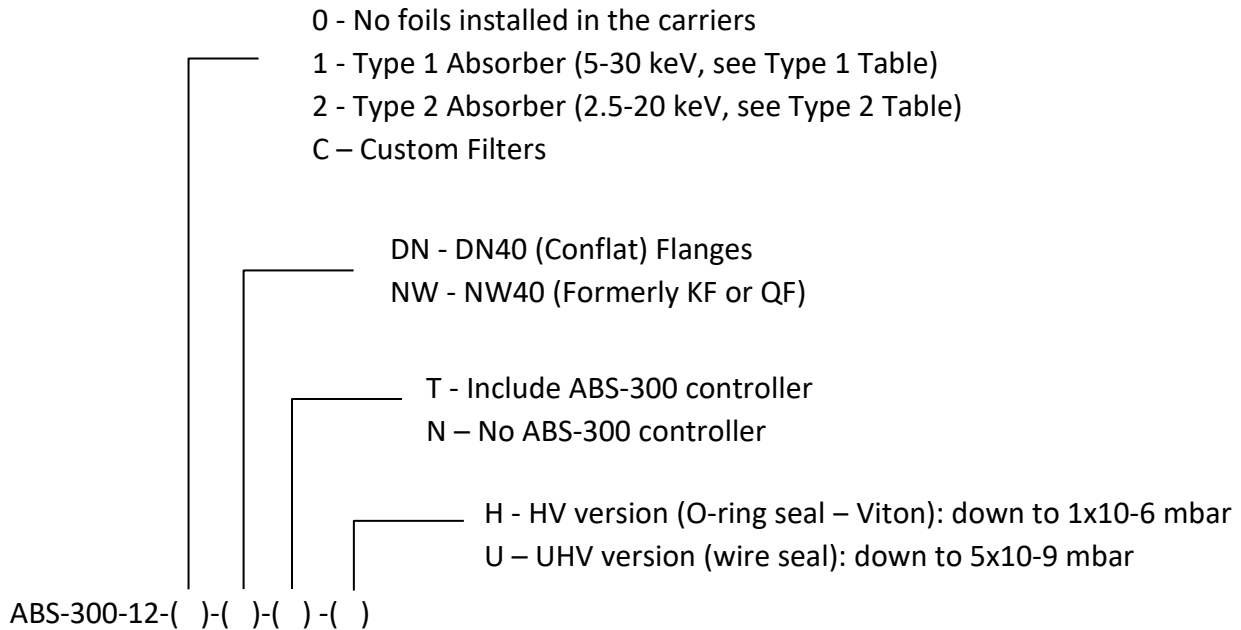

For example, a chamber configured for 5-30 keV with DN40 flanges, the ABS-300 controller, and UHV version would be denoted by: ABS-300-12-1-DN-T-U

CONTACT US



QVS

Pol. Ind. Sigma, Xixilion kalea 2, Bajo,
Pabellón 10
20870 Elgoibar, Gipuzkoa, SPAIN
T +34 943 821 841
F +34 943 821 842
avs@a-v-s.es

QVS|UK

Rutherford Appleton Laboratory
Harwell Campus
OX11 0QX Didcot, Oxfordshire, UK
T +44 (0) 1235 567095
avs@a-v-s.uk

QVS|US

126 Ridge Rd
Lansing, NY 14882, USA
T +1 607 533 3531
F +1 607 533 3618
avsus@a-v-s.us

UFG

Westcott Venture Park
Aylesbury HP18 0XB
Buckinghamshire, UK
T +44 (0) 1235 567095
agarbayo@a-v-s.uk



Parque Empresarial Tactica
Calle Velluters 17
46988 Paterna, Valencia, SPAIN
T +34 961 344 831
F +34 961 344 830
comercial@vacuum-projects.net

SCIENTIFICA

Pol. Ind. Sigma, Xixilion kalea 2, Bajo,
Pabellón 10
20870 Elgoibar, Gipuzkoa, SPAIN
T +34 943 127 285
scientifica@scientifica.es