

Pump Data

- SH7.5 HP 7-11/16 Imp, 1 Stage Centrifugal Pump
- 316L SS Corrosion Resistance Construction
- Built-In Overload , Auto-Reset Provided
- 25amp 230V Single Phase UL Motor
- *110V not available
- 2 F NPT Suction

Pump Flow

(not for certification use)

GPM	0	40	60	80	100	150
PSI	94	88	82	73	67	39

Components

Model F-SH752-D

- A - Flow Switch
- B - 1-1/2 Galvanized Riser F NPT
- C - Supervised Control Valve
- D - Pressure Gauge
- E - D Panel Control Box with Full Steel Frame
- F - 40 60 Pressure Switch
- G - Bypass Line w/ 3/4 Backflow Preventer
- H - SH 7.5 HP UL Motor w/Pump
- *Wiring in Liquid Tight Conduit (not shown)

Check Box for Optional Equipment

- I - Butterball Tamper Switch

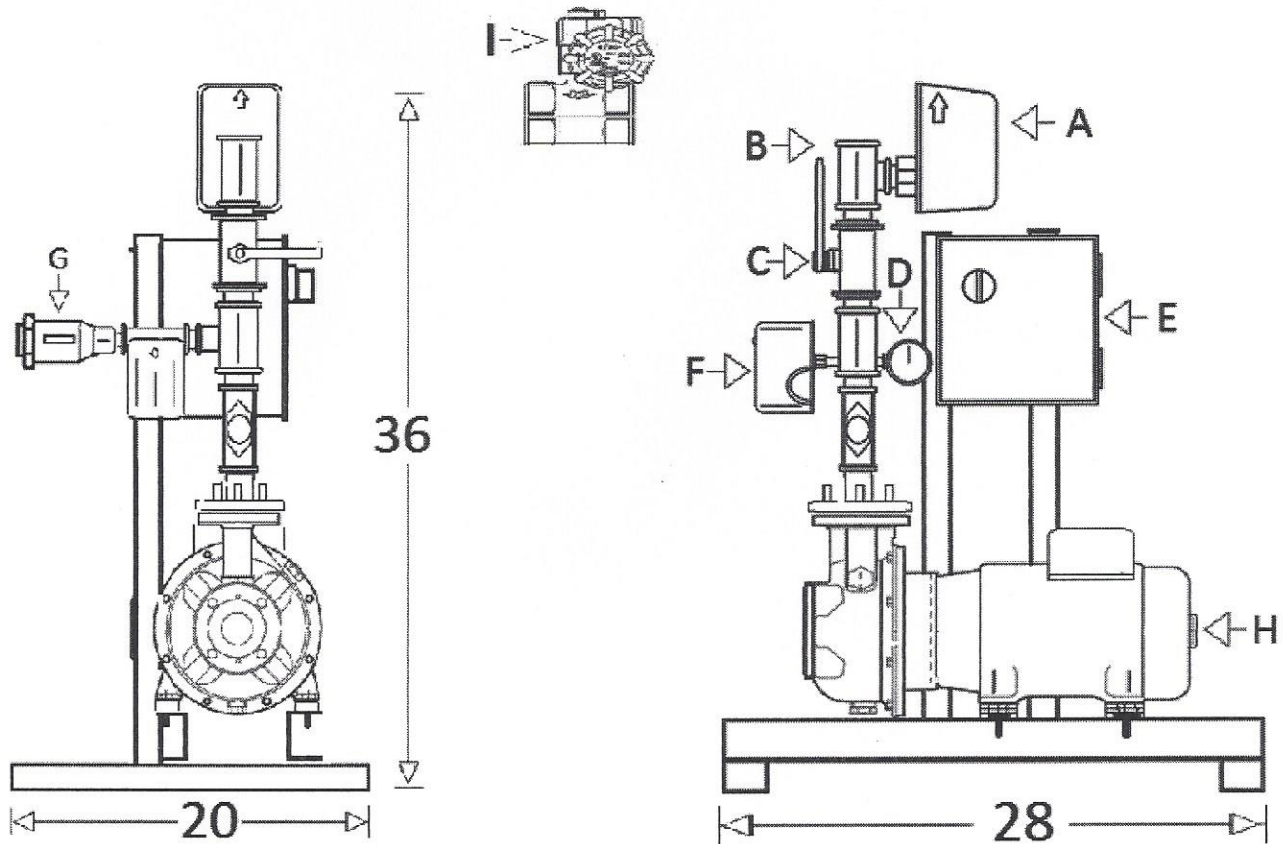

*Note: all measurement in inches