

Owner's Manual

IW-B7
IW-C7
IW-SR30



Snell

SPECIFICATIONS**IW-SR30**

Frequency Response (± 3 dB)	78 Hz-20 kHz
Recommended Amplifier	10-150W
Nominal Impedance	6 ohms
Sensitivity (2.83v at 1m)	87dB SPL
Tweeters	(2) 1" aluminum dome, ferrofluid cooling and heatsink. "Directed Power" waveguide in dipole configuration
Midranges	3 1/2" Midrange, edge-mounted in dipole configuration
Bass Driver	6 1/2-inch (165mm) copolymer with butyl rubber surround
Crossover Point	400 Hz, 2.5 kHz
Composite Baffle	Specialty adhesive between two 1/4" layers of HD fiberboard
Grille	Perforated metal, 53% open
Dimensions (HxWxD)	23 1/4 x 13 1/4 x 3 3/4 inches (590 x 336 x 95mm)
Rough Opening Cutout (HxW)	22 x 12 inches (559 x 305mm)
Finish*	White trim, suitable for painting
Shipping Weight	22 lbs (10kg) each

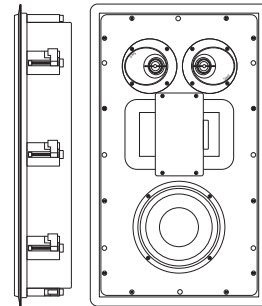

Manufactured under license from Lucasfilm Ltd.
Lucasfilm and THX are registered trademarks of
Lucasfilm Ltd.

IW-C7	IW-B7
63 Hz-20 kHz	63 Hz-20 kHz
75-250W	75-250W
6 ohms	6 ohms
90dB SPL	89dB SPL
1" Seas silk dome	1" Seas silk dome Hexadym magnet
(2) 4 1/2" in separate enclosure, Seas treated paper cone	(2) 4 1/2" in separate enclosure, Seas magnesium cone
(2) 8-inch (203mm) copolymer with butyl rubber surround	(2) 8-inch (203mm) copolymer with butyl rubber surround
275 Hz, 2.5 kHz	275 Hz, 2.5 kHz
Specialty adhesive between two 1/4" layers of HD fiberboard	Specialty adhesive between two 1/4" layers of HD fiberboard
Perforated metal, 53% open	Perforated metal, 53% open
42 x 14 x 3 3/4 inches (1067 x 356 x 95mm)	42 x 14 x 3 3/4 inches (1067 x 356 x 95mm)
40 7/8 x 12 7/8 inches (1039 x 327mm)	40 7/8 x 12 7/8 inches (1039 x 327mm)
White trim, suitable for painting	White trim, suitable for painting
45 lbs (20.4kg) each	48 lbs (21.8kg) each

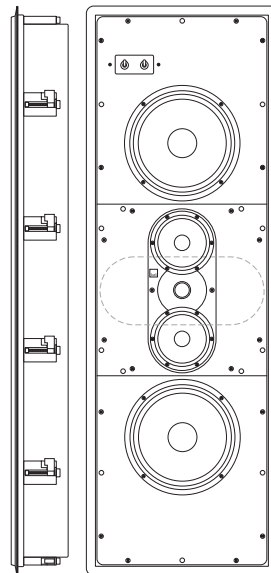

INTRODUCTION: WHAT IS A HIGH END IN-WALL?

The Snell IW series units bring a novel approach to the design and construction of in-wall loudspeakers, expanding the boundaries of in-wall performance.

Our primary goal was to develop loudspeakers that delivered performance that was as close as possible to that of our highly regarded in-room loudspeakers, like the B7 and C7 tower and SR30 on-wall. To do this, several issues had to be addressed.

The bass performance of conventional loudspeakers mounted in wall cavities is very unpredictable. Cavity volume can be large, which should be good for bass performance. However, with one very short dimension (approximately 4") and one very long dimension (up to 8'), the wall cavity takes on the characteristics of a closed-end organ pipe. This creates a strong resonance that tends to null out the bass. Lining this cavity with fiberglass will reduce the "Q" of the notch but not restore the bass. What is needed is a defined volume of a more regular size. This is best done with fully enclosed in-wall speakers.

The Snell IW loudspeaker enclosure is a thin, but strong, aluminum tub. It is both damped and braced. This largely contains the back radiated sound of the woofer within the enclosure. An added benefit of containing the woofer output is a reduced chance that resonances will be excited in the house walls. Furthermore, sound "bleed through" to adjacent rooms is reduced.

To minimize resonances in the Snell enclosure, the speaker baffle uses a technique first pioneered on our .5 and XA series loudspeakers. The baffle is a three part composite with MDF (fiberboard) outer layers around a thin, but highly effective, damping layer. This controls the panel resonances of the baffle that can obscure midrange clarity. As we have found with our freestanding loudspeakers, a better loudspeaker cabinet means a better sounding loudspeaker.

Another unique feature of the IW-B7 and IW-C7 is their rotatable midrange/tweeter panel. The entire center panel of the baffle can be removed and rotated, making the speaker suitable for horizontal installation. In this configuration the IW-B7 or IW-C7 become the ultimate center channel speaker. Note that in this configuration the speaker cannot be installed between the wall studs. Special, custom installation is required.

In addition to these unique solutions, all traditional Snell attributes are retained. Highly coherent in-phase crossover networks ensure a seamless blend from driver to driver. Drivers are designed for smooth, wide range response and low distortion. The IW-B7, IW-C7 and IW-SR30 meet the sonic requirements of digital 5.1 and 7.1 channel surround sound systems as well as the demanding specifications of THX Ultra 2. Long sessions of listening and adjusting give each system that special, characteristic Snell sound. Finally, that Snell sound is guaranteed in every production pair by Snell's proprietary 0.5dB production tuning techniques.

PLACEMENT OF THE IW-B7 AND IW-C7

A home theatre system includes three loudspeakers placed across the front of the listening room. The distance between the left and right speakers determines the width of the stereo image. If the speakers are placed too close together, the image will be too narrow; too far apart and the blend will suffer, creating a hole in the middle. When properly placed, your speakers will create a continuous "virtual image" from left to right, with an illusion of sound outside, in front of, and behind the speaker systems.

We recommend an angular separation between 45 degrees and 60 degrees (when viewed from above). This is equivalent to a separation between the speaker systems that is about 85% of the distance to either of the speakers.

Creation of sounds between the speakers requires some precise placement. The distance from the left speaker, right speaker, and center channel to the listener location should all be as equal as possible. We advise using a tape measure to equalize these two distances to the primary listening location.

Ideally the front channel speakers should be installed at the same height as the ears of a seated listener. Try to keep the front channel tweeters within two vertical feet of that height.

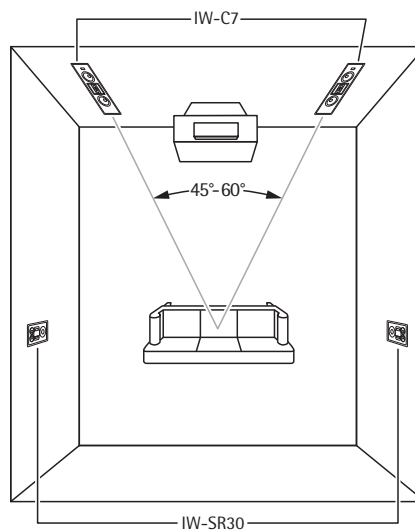

PLACEMENT OF THE IW-SR30

There are many opinions about where surround or "rear" speakers should be mounted. The following is based on the findings of the best academics, and on our experience with many installations.

In a typical 5.1 surround system a dipole surround speaker, such as the IW-SR30, performs best when it is mounted directly to the sides of the listener plus or minus 15 degrees or so. This places the listener in the "null plane" of the speaker. For a listener positioned on the null plane, the output of the two tweeters and the midrange will be at maximum cancellation. The listener will hear the speaker only via multiple wall reflections—producing the most diffuse sound.

Whenever possible mount the IW-SR30's high on the side walls of the room, at least one foot above the height of a standing listener.

The second preferred position is on the back wall. If may be necessary to mount the speakers closer to the center line of the room to keep the listening area in the $\pm 15^\circ$ null plane.

If neither of these positions can be used, mounting the speakers in the ceiling can be considered. Ceiling mounted speakers should be close to the side walls, well away from an overhead position.

If a large theater room with three or more rows of seats is planned, then more than one pair of IW-SR30 may be used to give more even coverage and a more diffuse sound field. We recommend that a pair of surrounds be used for every other seating row (the first, the third, the fifth, etc.). This follows standard cinema practice.

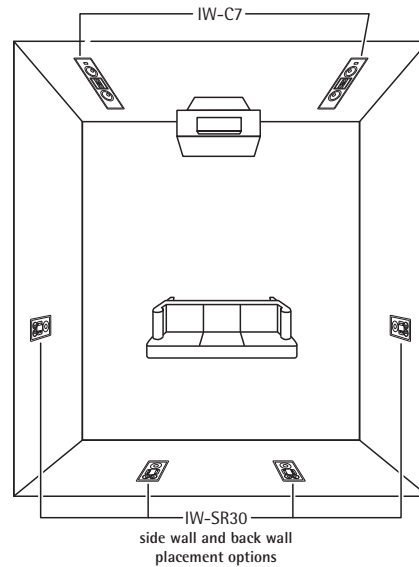

AN IMPORTANT NOTE ABOUT INSTALLATION

This manual assumes that the installer possesses skill in the proper use of hand and power tools, knowledge of local building and fire codes, and a familiarity with the environment behind the wall or ceiling in which the speakers will be installed. If you do not have the necessary skills and knowledge, have the speakers installed by a professional.

Optional preconstruction brackets are available for the IW-SR30.

PAINTING THE SPEAKERS

If you intend to paint the speakers, it is best to do so before installation.

- 1) Remove the speaker grille.
- 2) Mask the baffle.
- 3) After painting, carefully remove the paint mask.

Note: Custom paint and grilles are available for an extra charge.

PREPARING FOR INSTALLATION

Map out the wiring paths from the speakers to the amplifier. We recommend 16-gauge wire for runs up to 25 feet, and 14-gauge wire for longer runs. Be sure the speaker wire does not rest or rub against any sharp or pointed objects.

The speakers should be mounted on a flat surface to form a good seal between the speaker flange and the mounting surface.

When connecting more than two speakers per amplifier channel, you should use series/parallel wiring. In all cases, make certain that the total impedance does not fall below the amplifier's rating. If you are not sure, contact your Snell Acoustics dealer.

You will Need:

- 1) A utility knife, an electric jigsaw, or other means of cutting a hole in the mounting surface.
- 2) A #2 Phillips screwdriver.
- 3) A wire cutter or stripper for preparing the speaker wires.

With the supplied hardware, the speaker can be installed in existing walls or ceilings from 1/2" (12mm) to 1 1/2" (38mm). For thinner walls, you will need to use spacers for the mounting legs (Contact your Snell dealer for this optional rubber part).

INSTALLATION

For convenient installation, the IW-B7, IW-C7 and IW-SR30 use a dog-leg mounting system. (See illustrations below). This provides a quick and clean install. Furthermore, the dog-legs can be removed if a particular situation requires to speaker to be directly attached to a stud.

- 1) Make an appropriate size speaker mounting cutout in the wall material.
- 2) Run the wire from the amplifier to the cutout. Allow an extra foot of wire at the cutout. Strip 1/2" (12mm) off the wire, and tightly twist the wire strands together.
- 3) Remove the speaker grille.
- 4) Insert the speaker wires into the spring terminal binding posts.

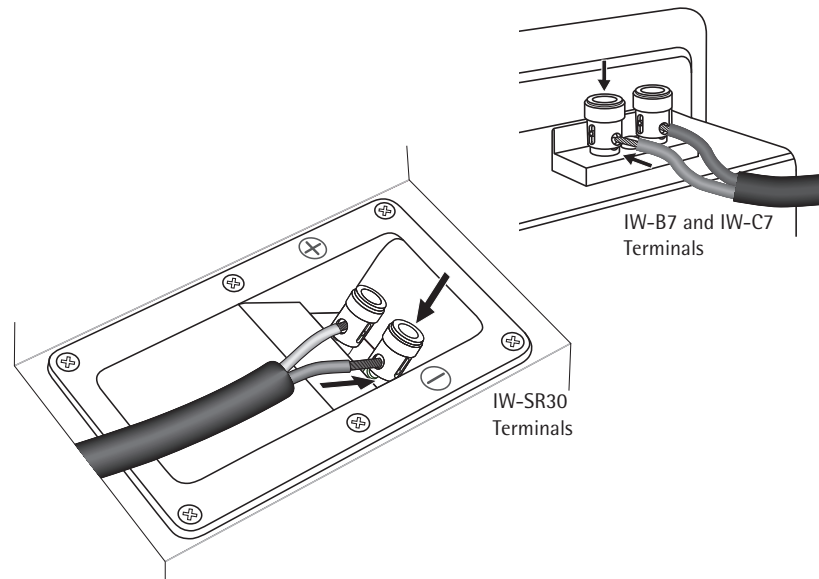

Important: Typically, one side of the wire is smooth. Connect this side to the - (black) speaker terminal. The other side has a rib or stripe. Connect this to the + (red) speaker terminal. Connect wire at the amplifier in the same way. Failure to do so will result in degraded sound.

Warning! To prevent electrical shock, always switch off the amplifier or receiver when making connections to the speaker system.

- 5) Place the speaker into the rough opening and level it.

- 6) Tighten (drive clockwise) the screws that turn the mounting clamp dog and tighten them. Try to tighten each clamp the same amount, being careful not to over tighten them. See diagram below for details.

Turn the mounting clamps against the enclosure, then place the speaker in the mounting hole. Use a phillips head screwdriver to deploy the mounting clamps and pull them against the back of the drywall.

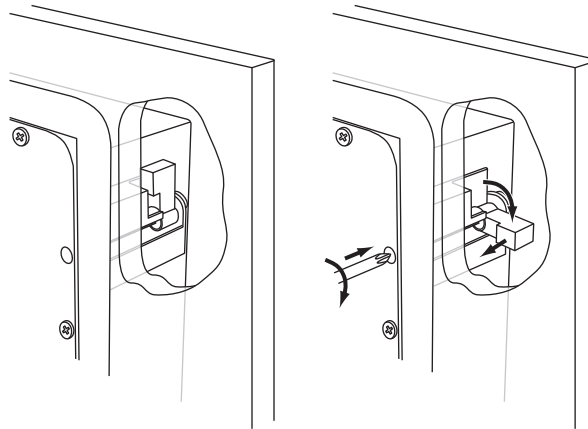

- 7) Replace the speaker grille.

Note: The IW-SR30 is sold in pairs. On the cabinet, near the input terminals, is a temporary label to specify screen direction. The response will be slightly superior in this direction. Install the two IW-SR30's so that the arrows BOTH point toward the screen. If listeners are not going to be located on or near the center axis of the speaker, the speaker should be oriented with the arrow toward the listener location (even if this is away from the screen).

SETTING THE IW-B7 AND IW-C7 CONTROL SWITCHES

The IW-B7 and IW-C7 have three switches that let you adjust its sound to suit your listening environment.

Bass Loading – When a speaker is placed close to a corner (or any boundary that forms a corner such as a fireplace or a large column), the bass output is emphasized. Setting the Bass Loading switch to the Boundary position slightly reduces bass output, thus preventing the "heavy" sound quality that can result from a speaker being placed close to a corner. When the IW-C7 is positioned at least 18" from the corner the Normal switch position will usually produce the best sound balance.

Treble Level – This 3-position switch controls the "brightness" of the sound. Set the switch to "+1dB" to increase the high-frequency output in situations where the speaker sounds "dull". This can occur when the listening room has a lot of heavy carpeting, drapes, etc. that absorbs high frequency sound. Set the switch to "-2dB" when the sound is too bright, which can happen in rooms with more hard, reflective surfaces. For typical rooms, with a balanced mix of hard and soft surfaces, set the switch to "0dB".

LISTENING LEVELS AND POWER HANDLING

The power recommendation for the system assumes you will operate the amplifier in a way that will not produce distortion. All speakers can be damaged by even a modest amplifier if it is producing distortion. If you hear a gritty noise or other signs of strain, turn down the volume. Prolonged or repeated operation of your speakers with a distorted signal can cause damage that is not covered by the warranty. It is especially important that you do not overdrive the bass capability of smaller speakers. Watch for noises, such as pops, caused by the music's bass line. Use of the loudness control and/or full bass boost at louder volumes is likely to overdrive the woofer. Use such controls sparingly.

HOW TO CARE FOR YOUR SPEAKERS

- ▶ Use a soft terry cloth towel slightly dampened with water, glass cleaner, or a diluted mild detergent. The towel should be just damp enough to wipe the surface clean without leaving a trail of moisture.
- ▶ Do not use abrasive cleaners or any cleaner containing chemicals harsher than those found in glass cleaner.

LIMITED WARRANTY

For five years from the date of purchase, Snell Acoustics will repair for the original owner any defect in materials or workmanship that occurs in normal use of the speaker system, without charge for parts and labor.

Your responsibilities are to use the product according to the instructions supplied, to provide safe and secure transportation to an authorized Snell Acoustics service representative, and to present proof of purchase from an authorized Snell dealer in the form of your sales slip when requesting service.

Excluded from this warranty is damage that results from abuse, misuse, accidents, shipping, repairs, or modifications by anyone other than an authorized Snell Acoustics service representative. This warranty is void if the serial number has been removed or defaced.

This warranty gives you specific legal rights, and you may also have other rights that vary from state to state.

If Service Seems Necessary

Contact the dealer from whom you purchased the speaker system. If that is not possible, call us at 978-538-6262, or write to:

Snell Acoustics
300 Jubilee Drive, P.O. Box 3717
Peabody, MA 01961-3717

We will promptly advise you of what action to take. If it is necessary to return your speaker system to the factory, please ship it prepaid in the original factory packaging. Please note that Snell Acoustics will not be held liable for shipping damage due to improper packaging. After it has been repaired, we will return it freight prepaid in the U.S. or Canada.



For EU Customers Only

This symbol found on the product indicates that the product must not be disposed of with household waste. Instead, it may be placed in a separate collection facility for electronic waste or returned to a retailer when purchasing similar product. The producer paid to recycle this product. Doing this contributes to reuse and recycling, minimizes adverse effects on the environment and human health and avoids any fines for incorrect disposal.

©2008 Snell Acoustics. All Rights Reserved.
Specifications are subject to change without notice.
Manufactured under license from Lucasfilm, Ltd.
U.S. patent number 5,109,416. Foreign patents pending.
Lucasfilm, THX and Ultra 2 are trademarks or registered
trademarks of Lucasfilm, Ltd.
Part #542-1052

Snell

300 Jubilee Drive, P.O. Box 3717
Peabody, MA 01961-3717
phone: 978-538-6262
fax: 978-538-6266
email: info@snellacoustics.com
www.snellacoustics.com