

Model F-SH75-RC

Pump Data

7.5HP 7-11/16 Imp. Single Stage Centrifugal Pump

Built-In Overload With Auto-Reset Provided

35amp 230V Single Phase UL Motor

2" Flange Suction

Pump Flow

GPM	0	40	60	80	100	150
PSI	94	88	82	73	67	39

Attention! This package uses an un-listed pump. For 13R application, be sure AHJ has approved use!

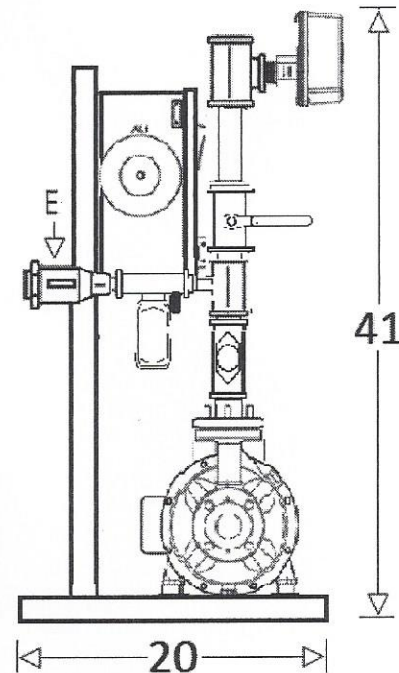

Components

- A. Flow Switch
- B. 1-1/2 F IPT Galvanized Riser
- C. UL Listed Residential Fire Pump Controller
- D. Supervised Control Valve
- E. Bypass Line with 3/4 F IPT Backflow Preventer
- F. Manual back up Water Pressure Gauge
- G. Electronic Pressure Transducer
- H. Powder Coated Steel Frame
- I. SH7.5 HP UL Motor Stainless Pump

Optional equipment

- J. 1-1/2 Butterball Tamper Switch

