

Features:

- All stainless steel construction
- True, 3" Full port
- Quarter turn open / close
- Bubble tight shutoff as defined by exceeding both ANSI/FCI 70-2-1976 Class VI and API 598 standards
- 45° Handle clears thickly insulated tank walls
- Uses standard hex head cap screws for easy installation
- Body Purge, Diaphragm Wash and Instrument Calibration performed through one port.
- Integral padlock locking device either open or closed

Description:

The Figure 305 B was the first patented TRANS-VALVE product. It is the only ball valve of transmitter isolation design with a full 3" port. This valve is corrosion resistant, bubble tight and easily installed as a replacement for knife gate valves or in 3" ANSI 150 # 4 bolt flange patterns. Bubble tight shutoff as valve exceeds both the API 598 and Class VI ANSI/FCI 70-2-1976 standards.

Number	Part	Material	Quantity
1	Handle	304 SS	1
2	Latch Lock	304 SS	1
3	Stop Pin	304 SS	1
4	Body	316 SS	1
5	1/4" NPT Plug	316 SS	1
6	Ball	316 SS	1
*	Stem	316 SS	1
7	Seats	RPTFE	2
8	Mount Pad	316 SS	1
9	Spring Washers	304 SS	2
10	Nut	304 SS	1
11	Handle Nut	304 SS	1

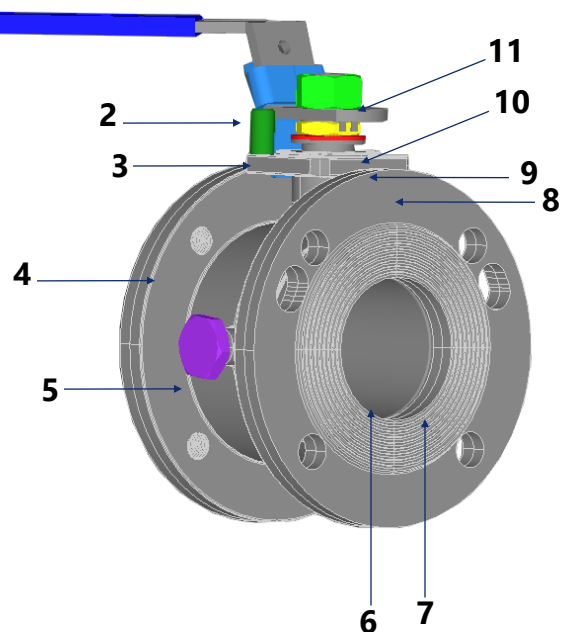

Technical Specification:

Valve shall be of a ball valve transmitter isolation design with a 316 stainless steel body and a true, full 3" port. It is to have a tank side flange to accommodate both: standard 3" ANSI 150 # 4 bolt flange pattern and a 26° to 28° offset (knife gate) flange pattern. The instrument end flange is to be drilled and tapped to accommodate a standard 3" ANSI 150 # 4 bolt flange pattern. Valve shall have a 45° offset stainless steel lockable handle. Valve is to include an integral actuator mounting pad. Valve to have single purge / calibration port, 1/4" NPT using a MNPT plug made of the same material as the ball and stem (316 SS). Single port flushes body cavity and diaphragm face when valve is open and allows pressure release, removal or calibration of transmitter when valve is closed. Seats to be made of RPTFE; retainer plate gasket and thrust washer in PTFE. Valve to use standard 5/8-11 hex head cap screws for easy installation. Valve tested to exceed both the API 598 and ANSI / FCI 70-2-1976 Class VI standards.