



TC51 Touch Probe



Workpiece Measurement



Infrared Transmission



Bidirectional



Wear-Free Measuring Mechanism



Mass Production



Axes Compensation



Pulling Measurement

Touch Probe TC51

BLUM
focus on productivity



TC51 | Touch Probe | Tactile workpiece measuring system with infrared transmission

Unique – high dynamic touch probe for fast pulling measurements

- Mass production
- Measuring tasks requiring superior precision
- Extremely fast measurements
- Thermal compensation of the machine tool
- Pulling measurement of grooves, recesses and outside width
- Spindle orientation is required

Your benefit:

- Measuring speed up to 5 m/min
- Highest acceleration
- Superior precision
- No-wear, optoelectronic measuring mechanism
- Highest process reliability
- Use of two measuring systems with one IR receiver
- Extended battery life
- Precise measurement even with coolant
- Proven and robust design

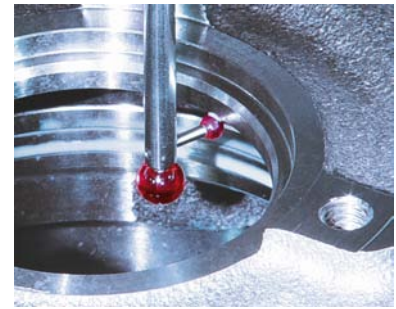
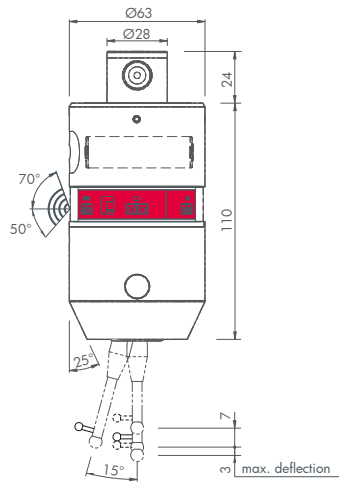

TC51 – Pulling measurement



TC51 – extremely fast and precise

DUO-Mode

Sequential use of two measuring systems with one infrared receiver.

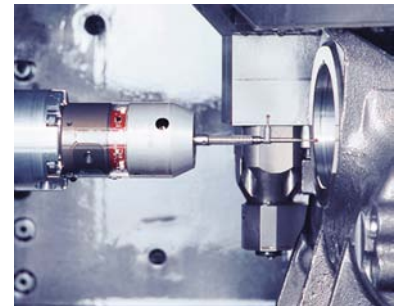

TC51 – ideal for mass production

Technical data

Protection class	IP68
Approach directions	XY*, ±Z
Measuring force in XY Z	1,5 N** 4 N
Max. deflection XY +Z / -Z	15°* 3 mm / 7 mm
Trigger point XY	0,5 mm / 0,8 mm / 1,2 mm / 1,5 mm ***
Trigger point Z	0,8 mm
Max. acceleration	100 m/s ²
Repeatability	0,3 μm 2σ
Max. probing speed	5 m/min
Mass	920 g
Signal transmission Range	Infrared ±60° in Z, 360° in X/Y
Battery (2 pieces)	Soft Lithium LS 14500 (AA, 3,6 V) 2600 mAh
Tool holder	BTH 50 (HSK, SK, BT, VDI, ...)
Storage/Operating temperature	-20 °C ... +70 °C +5 °C ... +50 °C

* Via spindle orientation ** Stylus L= 50 mm
 *** Stylus L= 50 mm / 100 mm / 150 mm / 200 mm

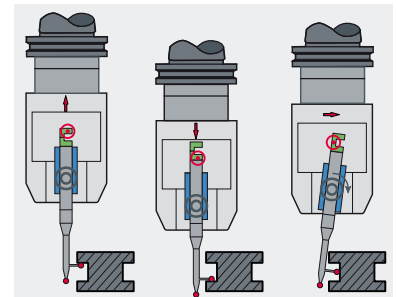

Modern and precise measuring mechanism with optoelectronic signal generation

BLUM
 focus on productivity

**Blum worldwide
 Service & Support**

More than 40 subsidiaries
 and service offices.

www.blum-novotest.com

Blum-Novotest Ltd.

33 Townfields
 Lichfield, Staffordshire
 WS13 8AA, United Kingdom

Phone: +44 1543 257111
 Fax: +44 1543 251746
 E-Mail: info@blum-novotest.co.uk

Blum LMT, Inc.

4144 Olympic Boulevard
 Erlanger, KY 41018
 USA

Phone: +1 (859) 344 6789
 Fax: +1 (859) 344 6799
 E-Mail: solutions@blumlmt.com