

★ RMS PARTNERSHIP ★

A NEWSLETTER FOR PROFESSIONALS

VOLUME NO. 15 ISSUE NO. 3

RELIABILITY, MAINTAINABILITY, SUPPORTABILITY

SEPTEMBER 2011

The Technology Transition Engineering and Management Framework and Guidebook

by *Jerrell T. Stracener, Ph.D.*
& *William H. Pincham III*

★ ★ ★

Introduction

The *Technology Transition Engineering and Management (TTEM) Guidebook* provides guidance for applying legacy principles using a tailor-able framework for creating and transitioning technology solutions. The TTEM framework was developed as a result of reviews and analyses that examined historical lessons learned documentation, techniques, and acquisition requirements embedded in Department of Defense (DoD) directives, polices, and procedures. The framework is unique in that:

- It provides a structure for framing engineering and management of technology transition decisions prior to Materiel Development Decision (MDD) and
- It provides a platform for linking developers of systems with developers of technology through practices, methods, and tools sets as they evolve.

The TTEM guidebook discusses details of how to apply and engage a TTEM framework structured for transitioning technology. Because the TTEM guidebook and framework consolidate historical DoD lessons learned into a cohesive system of knowledge management based decision activities, it can accelerate deployment of state-of-the-art technologies into Concepts of Operations (CONOPs). Engineering and management guidance is provided for three summary level framework activities through decomposed sub level activities and decision gates as follows:

- 1.0 Identify Technology Candidates and Screen (Pre-Milestone A)
- 2.0 Develop Evaluation Criteria
- 3.0 Transition To Development (Post-Milestone B)

Figure 1 shows the relationship of summary level TTEM Framework activities at the summary level (following page).

Since the guidebook documents an approach that explicitly states principles for identifying—and finding—and transitioning technology, it applies to users who are looking for a Materiel solution to warfighter needs defined by Doctrine, Organization, Training, Materiel, Leadership and Education, Personnel and Facilities (DOMLEPF) analyses. It can be used by end-users and developers who are looking for a solution to a need as well as to researchers who believe they may have achieved a technology state-of- the-art

CONTENTS

The Technology Transition Engineering and Management Framework and Guidebook

Jerrell T. Stracener, Ph.D. & William H. Pincham III 1

Renewing and Reshaping the RMS Partnership Service to Government, Industry and the Academic Community

Russell A. Vacante, Ph.D. 1

Fidelity in Critical Component Provisioning Planning Despite a Variety of Evolving Repair and Manufacturing Capabilities

Giancarlo Newsome & Roy Bryant..... 6

RMS Partnership Newsletter
Editor-In Chief, Russell A. Vacante, Ph.D.

Published quarterly.

Renewing and Reshaping the RMS Partnership Service to Government, Industry and the Academic Community

by *Russell A. Vacante, Ph.D.*

★ ★ ★

Beginning this month The RMS Partnership will begin to take on a different look as its scope, direction and perspective is expanded and made increasingly diverse. However, prior to discussing some of the changes taking place within the RMS Partnership it is important to mention that our core mission will not be significantly altered. Since 1993 we have been a professional organization that has focused on ensuring that reliability remains an important integral part of the systems engineering and life cycle management processes. This goal will remain unchanged. As most of us know and understand, improving the reliability of systems and equipment can lower costs and save lives, while reducing the maintainability, supportability, and general logistics burden to the user community.

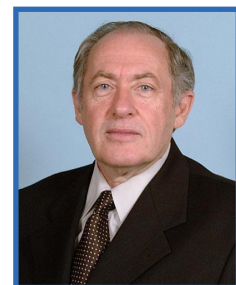

Soon we will be posting a new website that will display our new look and perspective. It will contain more graphics that will provide quicker and easier access to various topics of interest and related information important to our community. The RMS Partnership

{Editorial cont., 9}

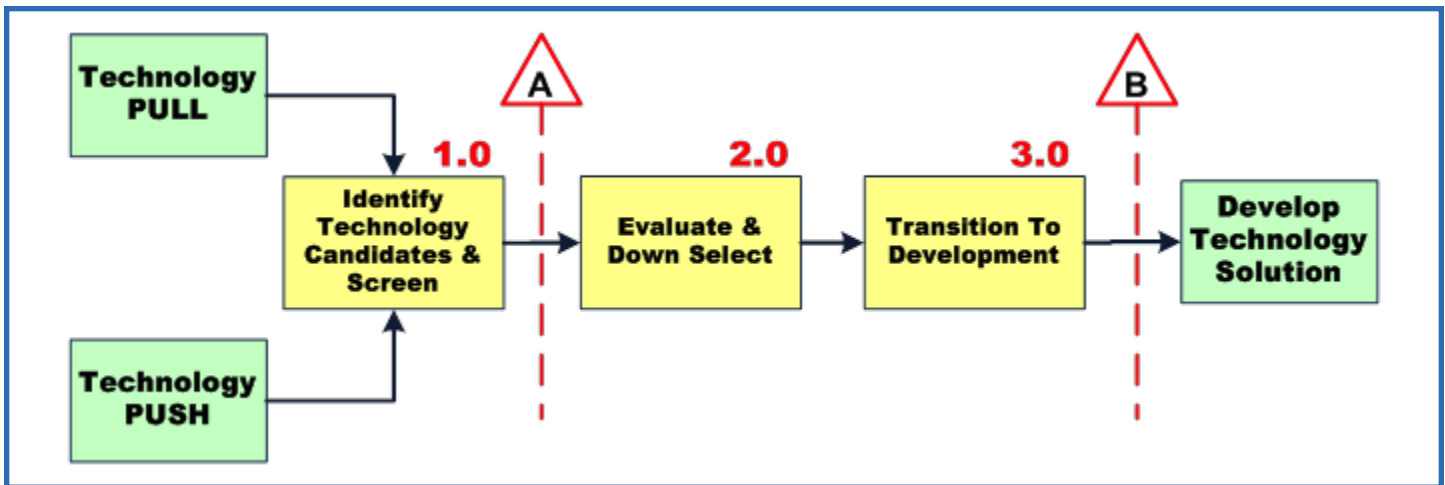

FIGURE 1 - TTEM FRAMEWORK: SUMMARY LEVEL

breakthrough with the potential for creating or enhancing previously unidentified CONOPs. It applies to technology development programs and to complex defense systems, both new development and upgrades. Therefore the TTEM framework and guidebook can be applied to both small and large businesses as well as DoD Programs of Record (POR) and commercial programs and projects.

History

In 2007, the Southern Methodist University (SMU) Systems Engineering Research Program (SEP) created an initiative focused on the goal of applying systems engineering principles to improve the efficiency of delivering effective Science and Technology (S&T) solutions that fulfill U.S. warfighter push and pull needs. The initiative was created by the SMU SEP to focus on identifying and resolving industry system-level integration design issues early in program life cycles. However, after a collaborative team of volunteer North Texas defense contractor systems engineering professionals conducted an initial evaluation, focus very quickly turned toward obtaining a more comprehensive and structured understanding of government perspectives of pre-acquisition technology decision dynamics across all agencies.

As a result of this initial effort, we now have a comprehensive knowledge management type database of over 250 agency documents that have been reviewed and analyzed and a first generation guidebook describing how “pre” acquisition system engineering technology integration relationships influence and impact Milestone B decisions. Since the initial effort was created to study government decision perspectives, Defense Acquisition University (DAU) representatives solicited participation of Air Force, Army, and Navy concept development specialists as team members. Jointly this collaborative team of government and industry representatives created a system engineered framework and a general practices guidebook that describes the overarching dynamics for identifying, selecting, and transitioning technologies into concepts of operations called the *Technology Transition Engineering and Management (TTEM) framework*.

The next phase of the research will focus on describing the dynamics associated with creating a “conceptual development” framework from an industry perspective for alignment with the government perspective. The goals of both research phases have two basic objectives:

- 1) Reduce the cycle time from user identification of need to technology solution delivery and
- 2) Reduce the risk of failure that an identified technology solution meets the original need.

Cycle time is the interval from the point in time when the end-user starts looking for a technology solution to a declared need until the point in time when the technology development community delivers the solution to the operational end-user. Risk of failure is the potential for developing a solution that does not meet the original needs of the user. Achieving these objectives will help:

- Save warfighter lives since technology solutions enter service faster;
- Create innovative medical technologies combating disease and injury on the battle field, and;
- Incentivize industrial base stability and availability by reducing the risk of cost overruns.

Concurrent with the publication of the guidebook, a plan has been created for additional framework refinement and decomposition and to grow linkages within the target user community. The plan includes a concept for developing a mathematical model of the framework and expanding the framework to include processes, tasks, methods, and tools. The framework has the potential, like no other approach at this time, for increasing the speed of technology transition. The guidebook provides the vehicle for creating knowledge awareness and feedback, while the framework provides the linkage of technology developers and users with evolving advances in practices, methods, and tools.

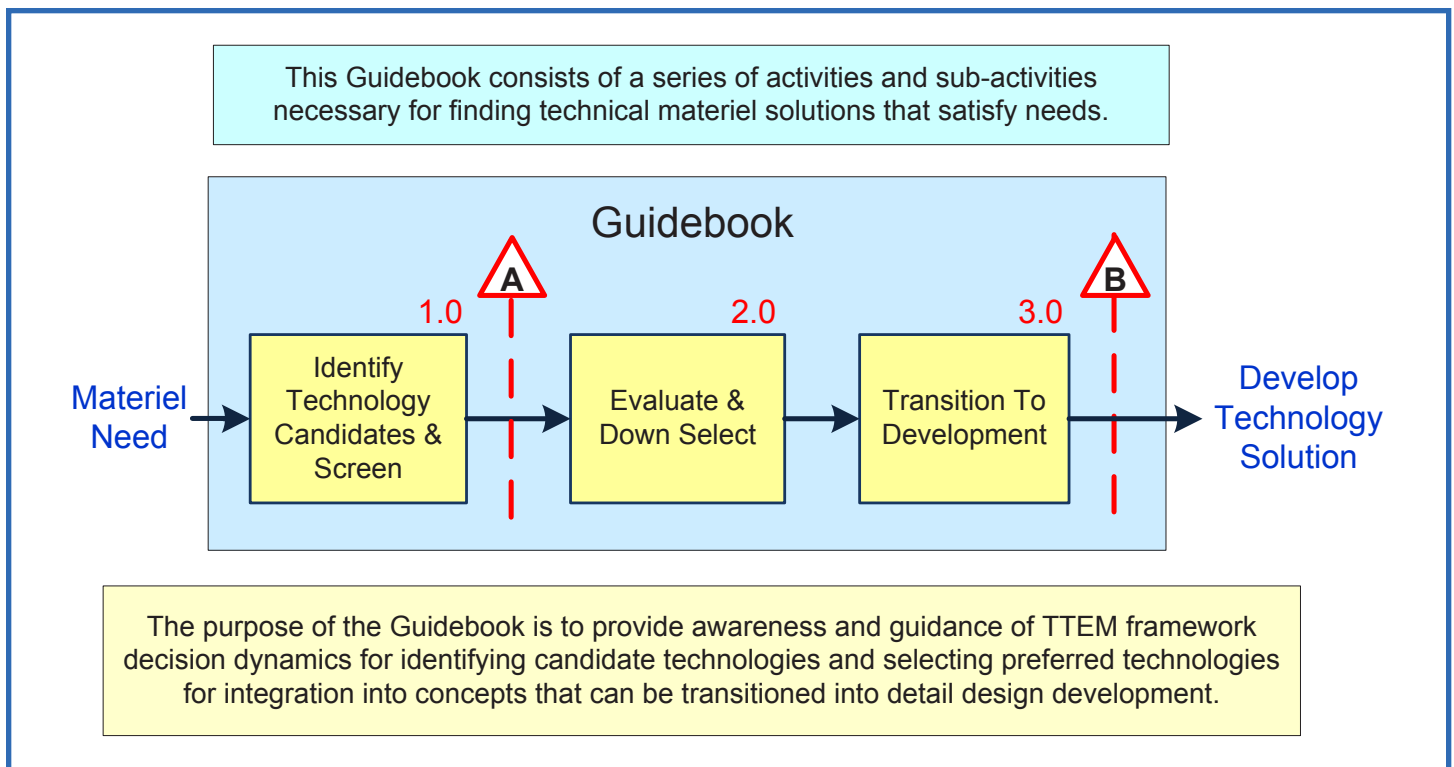

FIGURE 2 - TTEM FRAMEWORK GUIDEBOOK ACQUISITION LIFE CYCLE RELATIONSHIP

TTEM Guidebook Structure

The guidebook explains how to find a technology that solves a warfighter need and then how to transition that technology into a solution or concept that is ready for detail design. The guidebook describes the TTEM framework that starts with an operational end-user need and then highlights key guidance activities and practices for creating a solution as shown in Figure 2. Figure 2 illustrates the guidebook's boundaries and how TTEM framework summary activities are related to the acquisition life cycle. The top level is also called the "Tier 0" level.

The TTEM framework may be applied at lower levels of system indenture one need at a time, or many applications of the TTEM framework may be executed in parallel to address multiple component level needs at the systems or subsystems levels of indenture. The guidebook addresses full systems level transitions equivalent to a military program beginning at the Pre-Materiel Solutions Analysis Phase through Milestone B of the acquisition life cycle. It also addresses transitions that cover shorter intervals of the life cycle acquisition.

In addition, the guidebook illustrates how systems engineering can be used to guide development of technology and manufacturing readiness. The guidebook does not duplicate these practices. Instead, it refers to them and augments existing DoD Program Management (PM) and Systems Engineering (SE) guides.

Activity 1.0: Identify Technology Candidates and Screen

This activity describes how customer needs are converted into requirements and potential candidate technologies identified and screened.

- Inputs
 - Initial Capabilities Document (ICD) or Equivalent
 - DOTMLPF Change Recommendation (DCR) or Equivalent
- Output
 - Verified assessment against TRL/MRL - Level 4 criteria
 - Draft Capability Development Document (CDD) or Equivalent

Activity 2.0: Develop Evaluation Criteria

This activity describes how concepts resulting from the integration of candidate technologies are evaluated to select a preferred candidate for transition.

- Inputs
 - Draft Capability Development Document (CDD) or Equivalent
- Output
 - Technology Transfer Commitment Level Agreement Assessments

Activity 3.0: Transition to Development

This activity describes how the preferred technology or concept is matured in preparation for detail design development as entry criteria for Milestone B.

- Inputs
 - Current state TRL/MRL assessment
 - An established funding profile
- Outputs
 - Verified assessment against TRL/MRL - Level 6 criteria

TTEM Framework Structure

Each Tier 0 summary activity is composed of several Tier 1 activities and decision gates. Tier 1 activities are broken down into sub-activities. Detail Tier 1 TTEM activity and gate definitions are summarized in the guidebook along with more detailed integrated discussions in a workflow description format.

However, the framework structure is as follows. Tier 1 activities are designated as “1.1 and on.” Tier 1 activities are further broken down into Tier 1 sub-activities. Tier 1 sub-activities are designated as “1.XX.” Tier 1 sub-activities are broken down into workflow steps such as “Step A, Step B, etc.” when appropriate. Tier 1 activity, sub-activity, and workflow steps are identified in red at the top right of the block or diamond. Activity and sub-activity descriptions include a functional workflow diagram showing steps within the sub-activity. The flow is approximate. Tailoring deviations are permissible to allow more parallel execution of steps and to allow appropriate step modifications.

Figure 3 is a three-part diagram of Tier 1 TTEM framework activities and decision gates. Each part of the figure is part of a functional-flow block diagram showing how the TTEM framework is integrated with AT&L life cycle milestones. Un-numbered activities are outside the boundary of the framework.

Figure 3.1 shows the activities that create a list of candidate technologies for screening that meet derived technology requirements. In the decision gate icon, the word “technology” can refer to more than one technology or a single technology, or a component (or components), or a sub-system (or sub-systems), or a system (or systems). The level of functional indenture is independent of the Tier 1 activity workflow.

Figure 3.2 (following page) illustrates how selected technologies are evaluated within competing alternative concepts. As we use the term “concept,” we are referring to indenture levels based on the scope of potential solutions created by the technology development

community for meeting the operational need of the end user. Technologies are evaluated within a concept that is appropriate for the next higher indenture level (i.e.: component, sub-system, system, or family of systems) to arrive at a decision gate for selecting a preferred concept for transition. Dual or competing prototypes with competing technologies are evaluated in this activity section of the framework.

The third part is Figure 3.3 (following page). Figure 3.3 shows the activities that mature the preferred technology concept into a solution that is ready for detail design.

Summary

The Technology Transition Engineering and Management (TTEM) Guidebook was developed to meet the overarching requirement of providing guidance for a broad spectrum of potential users.

The target user community consists of individuals and organizations associated with developing and upgrading the capability of United States defense systems.

The target user community is made up of technology users and technology developers. The technology user segment is easy to define. It consists of U.S. DoD and defense contractor individuals and organizations. The technology developer segment is essentially unstructured and therefore difficult to define or characterize. Developers range from an individual with an idea to universities in collaboration with federally funded research labs, commercial labs, and product departments within organizations.

The guidebook has been created to provide a potential user in the target community with a guidance starting point. Guidance has been scoped to include only engineering and management associated with technology transition into detail design development.

Updates of this guidebook are planned based on (1) user feedback, (2) SMU PhD student research, and (3) continued development of the Technology Transition Engineering and Management (TTEM)

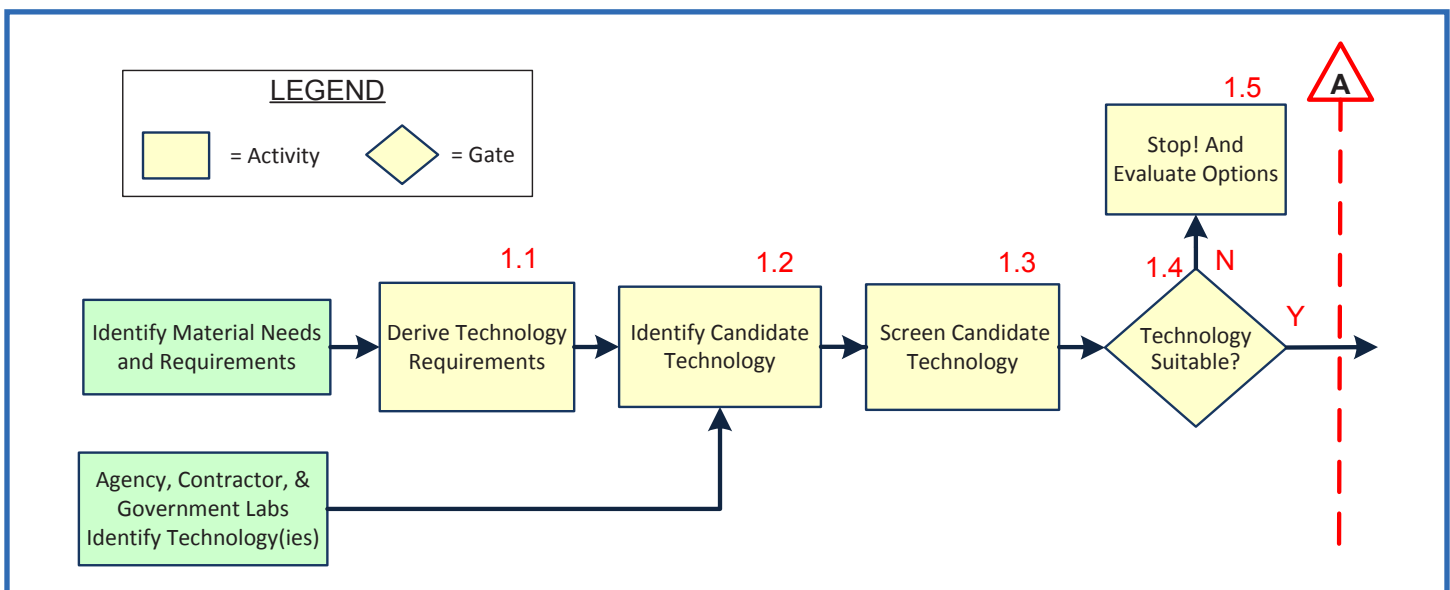

FIGURE 3.1 - ACTIVITY 1.0: IDENTIFY TECHNOLOGY CANDIDATES AND SCREEN

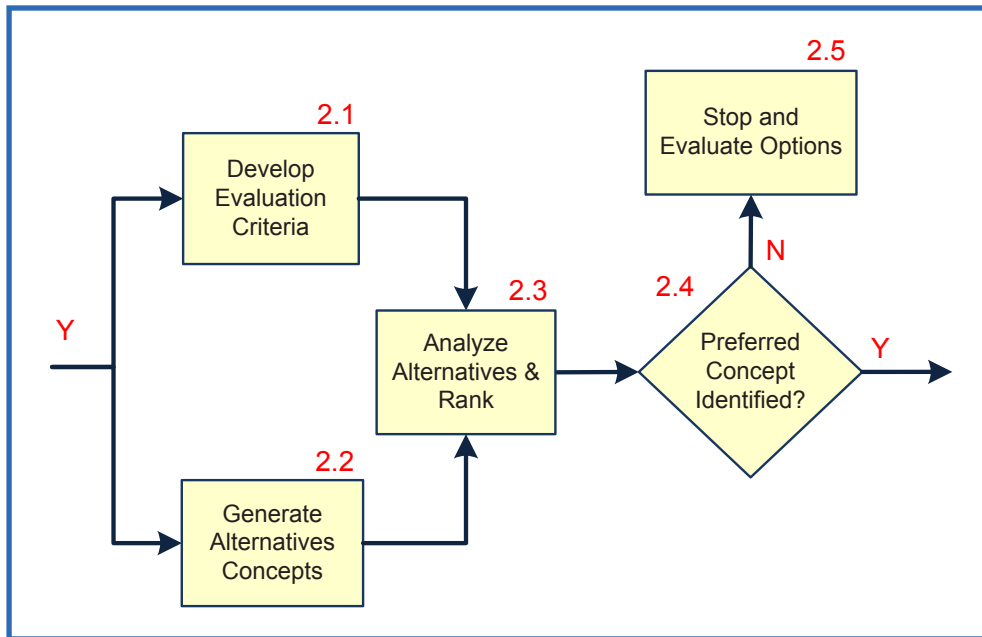

FIGURE 3.2 - ACTIVITY 2.0: DEVELOP EVALUATION CRITERIA

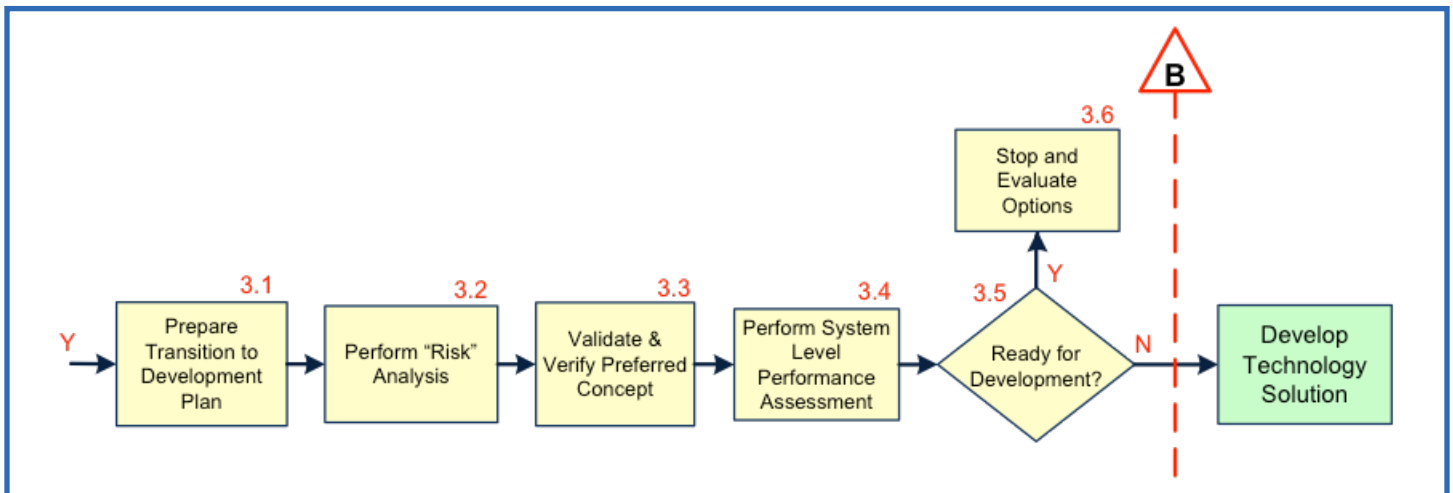

FIGURE 3.3 - ACTIVITY 3.0: TRANSITION TO DEVELOPMENT

framework. Updates based on (1) and (2) above cannot be planned, as they are dependent on the future actions and responses of individuals that are or may become associated with the guidebook. User feedback and research results will be used to guide future research and development of the framework and guidebook updates.

The plan is to post the guidebook for electronic access and then publicize its availability using media within the target community. A user network is expected to evolve to capture user experiences with the guidebook and provide a means of linking users. ★

About the Authors

Dr. Jerrell T. Stracener is Associate Professor and founding Director of the Southern Methodist University (SMU) Systems Engineering Program. He teaches graduate-level courses in systems analysis methods and applications, and directs and conducts systems engineering research. He is the SMU Lead Senior Researcher in the DoD funded Systems Engineering Research Center (SERC). Prior to joining SMU full-time in January 2000, Dr. Stracener was employed by LTV/Vought/Northrop Grumman. He conducted and directed systems engineering studies, and analysis, with focus on systems reliability and supportability, on many of the nation's most advanced military aircraft. Jerrell was co-founder and leader of the SAE Reliability, Maintainability and Supportability (RMS) Division (G-11). He is an SAE Fellow and AIAA Associate Fellow. Dr Stracener earned Ph.D. & M.S. degrees in Mathematical Statistics

from SMU and a B.S. in Math from Arlington State College (Now the University of Texas at Arlington).

William H. Pincham III is a Principle Consultant with System Design, LLC and a Research Assistant for the SMU Systems Engineering Department. He was the 2008-2010 Operations Vice President of the RMS Partnership. In 2008, he retired from Lockheed Martin Missiles and Fire Control (LMMFC) as the Manager of Business Systems for Advanced Manufacturing Technologies. As a member of the SMU System Engineering Development Team, he was a key researcher and the author of research reports submitted to the U.S. DoD DAU entitled "Technology Linkage, Selection and Transition (TLST) to the U.S. Warfighter," March 2010 and "Science and Technology Systems Engineering Research Phase 0 Report," December 2008. In addition he was a key author of the Phase 1 report and the resulting "Technology Transition Engineering and Management" Guidebook, published July 2011.

Mr. Pincham earned MSSE (2007) and MBA (1997) degrees from Southern Methodist and a BSIE (1972) from the University of Tennessee.

INTERESTED IN CONTRIBUTING?

If you are interested in sharing your knowledge in future editions, please contact Russ Vacante at russv@comcast.net. Articles can range from one page to five pages and should be of general interest to our members.

YOUR AD HERE!

For details, please contact Taylor Hughes at (703) 629-9337 or email him at t.k.hughes@cox.net.

RMS PARTNERSHIP 2011 MEMBERSHIP NOW AVAILABLE!

The RMS Partnership has been serving the reliability, maintainability, supportability/logistics, and systems engineering community since 1993. It is a high value, low cost training and education organization that provides quarterly newsletters, a professional journal twice annually, on-site training, tailored organization workshops and an annual workshop and symposium. Low cost consulting services are also available.

Individual Membership – Annual dues \$30.00
Corporate Membership – Annual dues \$2,000.00

The RMS Partnership is a 501(c)(3) not-for profit organization. This tax status makes it possible for individual and corporate members to make donations that are deductible on their own tax returns.

Please contact RMS Partnership membership director Bernie Price or visit www.rmspartnership.org for more info.

Fidelity in Critical Component Provisioning Planning Despite a Variety of Evolving Repair and Manufacturing Capabilities

by Giancarlo Newsome & Roy Bryant, Clockwork Solutions, Inc.

★ ★ ★

Overview

A renowned military organization tasked Clockwork Solutions Inc. to conduct credible and actionable predictive modeling and simulation analysis to help this organization determine proper provisioning of a critical component for a particular military system for the next ten years. This military system is a key component of this military's global force posture. These critical components are extremely costly and critically important to the operation of this system.

This provisioning study addressed operational availability requirements, cost thresholds, varied capabilities of repair and overhaul, varied types of component manufacturing sources, various operating locations, and other factors that were all changing over the ten year period of analysis. With this level of real world multi-faceted complexity incorporating evolving change over time, traditional life-cycle modeling and simulation methods fell short. Due to the high cost and critical nature of this component, this organization could not rely upon traditional deterministic methods that force users into applying large simplifying assumptions. This organization required that the fidelity of the analysis be extremely robust representing reality as close as possible. The well validated ATLAST™ high-resolution, discrete event simulation modeling analytical software was applied to this task.

ATLAST™ was selected by this military organization given its ability to represent highly complex, multi-indentured, changing life-cycle demand factors. With this capability in hand, the resulting analysis identified and corrected data incongruity between manufacturer and military operator in terms of condemnation rates or components that are deemed not repairable. This analysis also presented actionable cost/benefit analysis to facilitate the military organization in optimizing the cost of repair effectiveness deterioration versus new component procurement. Furthermore, the cost variance in carrying additional inventory versus expanding the work in process repair capacity (Turn-Around-Time) was also accurately compared.

Key Model Assumptions

OPTEMPO (Rate of System Operation): Approximately 100,000 units of operation per year from about 500 systems at approximately 30 bases, with each system operating between 50 and 1000 units per year each were accounted for.

New Component Procurement Plan: The model includes procurement contracts occurring at distinct points of time between November 2009 and December 2012 for new components.

Remanufactured Component Reintroduction: A portion of

the fleet of systems is being remanufactured. Within this upgrade program, serviceable (working) components are overhauled within the remanufacturing process (whether they need repair or not). The rotation and reliability of these components were included in the total pool of components.

Repair Location, NRTS/BCM (Not Repaired This Station or Beyond Capability of Maintenance) Rates, TAT (Turn-Around-Time) & Condemnation Rates: The component field repairs were captured as well as the corresponding NRTS/BCM rate by location was captured. These NRTS/BCM components were tracked to the next level of maintenance (overhaul) that consisted of several depot service centers. Each depot was modeled considering its different and limited repair capacity, turn-around-times, condemnation rates (components deemed not repairable), and repair processes.

Component Reliability and Repair Effectiveness Behavior: As shown in Table 1 below Weibull parameters were fit for the MTTF (Mean Time To Failure) reliability rate relative to the components type, number, and location of repairs. Each component (approximately 5000) was initialized into the model relative to its then current age and state.

The analysis allowed for alternate management strategies to be examined:

Procuring more new components instead of continuing to repair components.

With the cost of component repair 1/3 of the cost of a new

component, trade-offs in fleet availability and sustainment cost was assessed for condemning components at a 4000, 5000, 6000, 7000 units of operation depot screen intervals. This study considered only the material acquisition cost. It did not include the peripheral repair costs of the additional labor and other costs associated with each repair to include maintenance test flights, transportation costs, storage costs, etc.

Investing in reducing repair TAT (Turn-Around-Time) or increasing depot repair capacity.

The Analysis Identified Repair Capacity Constraints That Would Be Reached at one of the depot repair centers within the next year and continuing for another 6 years.

Three options and their trade-offs were examined:

- 1) Expanding repair capacity at the over capacity depot.
- 2) Diverting repairs to other repair centers that produce lower reliability repairs.
- 3) Procuring additional component inventory to offset the throughput bottleneck.

Conclusion

This military organization was provided a quality comprehensive comparative analysis that enabled them to accurately assess the outcome of several strategic options and to ultimately produce an actionable provisioning forecast. The provisioning forecast provided

				Weibull Parameters				Average Hours	
	PN	Last Repair	Repairs	Scale	Shape	MTTF	Installed	TSN	TSL
Type A	XXWYT01-23	New	0	1470	1.00	1595	251	674	674
	XXWYT01-23	Field	1	849	0.83	899	143	1200	241
	XXWYT01-23	Field	2+	631	1.00	686	246	2229	296
	XXWYT01-23	OEM	0	1021	1.01	1322	137	2225	462
	XXWYT01-23	OEM	1	849	0.83	899	60	2310	542
	XXWYT01-23	OEM	2+	631	1.00	686	167	2431	330
	XXWYT01-23	VENDOR	0	683	1.05	825	27	1981	281
	XXWYT01-23	VENDOR	1+	631	1.00	686	50	2392	265
Type B	XXWYT01-24	New	0	1560	1.00	1709	260	593	593
	XXWYT01-24	Field	1	660	0.91	704	139	1214	285
	XXWYT01-24	Field	2+	639	1.10	736	281	2528	280
	XXWYT01-24	OEM	0	1031	1.04	1344	122	2310	530
	XXWYT01-24	OEM	1	660	0.91	704	38	1886	684
	XXWYT01-24	OEM	2+	639	1.10	736	152	2528	280
	XXWYT01-24	VENDOR	0	922	0.80	956	28	2139	357
	XXWYT01-24	VENDOR	1	660	0.91	704	16	2118	291
XXWYT01-24	VENDOR	2+	639	1.10	736	48	2639	190	

TABLE 1 - REPRESENTATIVE STUDY VALUES

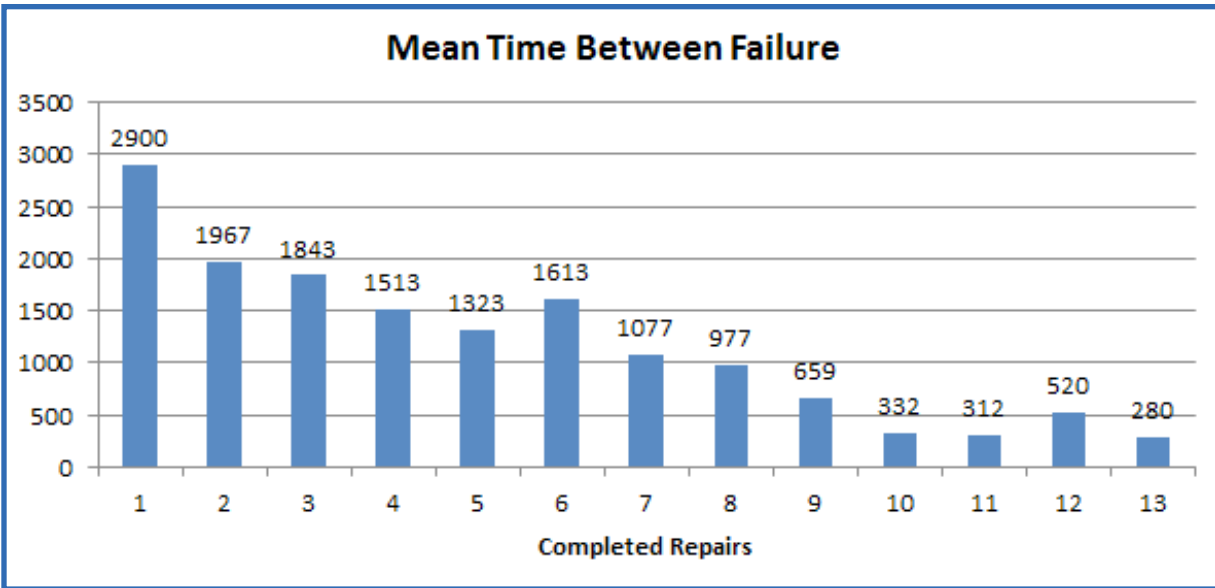

COMPONENT REPAIR EFFECTIVENESS AND COMPONENT RELIABILITY CHANGES OVER TIME

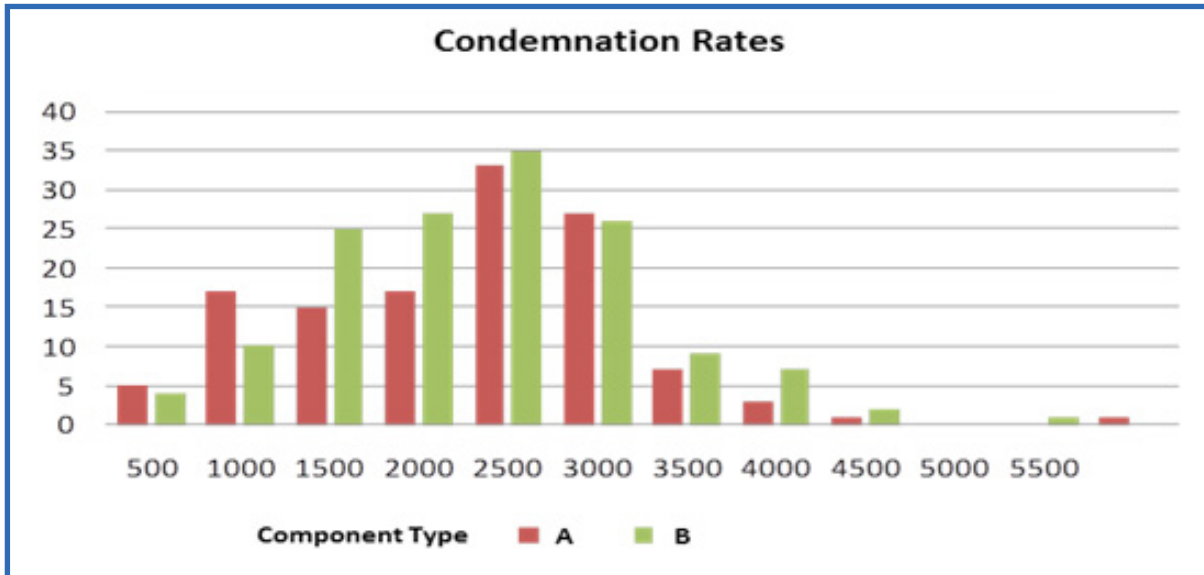

VARIATION IN CONDEMNATION BY COMPONENT TYPE AND AGE

included a buy plan of new components, expected removals (unscheduled and remanufactured), depot requirements, and expected condemnations.

In summary this comprehensive predictive modeling analysis capability allowed for initializing the model with the actual fleet life-cycle age and wear on parts (by serial number component), and then factored in planned OPTEMPO, observed failure rates, maintenance capacity constraints, current supply conditions, and planned programmatic fleet changes in the size of the fleet and/or the configuration of components, and their changes over time. This gave the military organization the foresight and confidence to adjust repair strategies, and to more efficiently use inventory in

maintaining the overall readiness of the fleets while recommending and assessing spare parts buy plans and programmatic decisions in view of expected OPTEMPOs rather than historical ones. ★

About the Authors

Roy Bryant has been conducting highly complex military system life cycle modeling and simulation for over 10 years. Roy has the unique background of having an extensive operational background as well as an advanced academic background. Roy's operational and academic background was principally formed in the backdrop of over 20 years of military services with the U.S. Marine Corps as a Naval Flight Officer. Notably, in tours as a Weapon Systems Support

OIC (Officer in Charge), an Operations Officer of a Marine Air Group, and as an executive in staff positions in the planning division of the U.S. Navy Atlantic Fleet command, Roy has experienced first-hand, for better and worse, the balance of art and science in life management of complex operations and systems. Combining his real world experience and abilities in Physics and Applied Mathematics (Naval Post Graduate School), Roy has served at various academic faculties to include the U.S. Naval Academy. As a teacher, Roy guided future leaders in applying math & science to solve real world problems. Roy has had an impact on industry as well where he has served several leading firms and their clients by helping them apply advanced scientific methods to reduce risk, reduce cost, and improve system productivity in their life cycle management decisions.

Giancarlo Newsome is a former Army Aviation commander who is accustomed to the operational challenges of people, parts, and equipment not being ready as advertised for a given future mission. As an industry business development professional, he has also worked for and with large aerospace OEM (Original Equipment Manufacturers) who are constantly challenged by improving how they supply and maintain such people, parts, and equipment. Giancarlo has also held executive leadership roles in digitizing analog equipment management systems enabling more finite and real time equipment health analytics. Giancarlo is a strong proponent of advanced predictive modeling and simulation technologies. He believes these technologies are the next frontier in significantly improving the management of the extreme complexity and changing nature of the enormous set of variables that influence total life-cycle management.

[Editorial, cont.]

website will be a living document in the sense that it will increasingly become interactive and updated in response to community interest and direction. The RMS Partnership Newsletter will continue to be a free on-line publication and our professional journal can be accessed under our membership button. The new members and membership renewals will remain as an on-line registration feature while being easier to navigate. Aside from these well-established and constant features the website promises to have many new features that are designed to draw a broader audience of new and existing visitors.

The on-site course offerings that the RMS Partnership provides will be skill specific. They will better attune to the immediate needs of the reliability, maintainability, supportability, logistic (RMS(L)) and systems engineering community. In the near future on-line courses will also be made available on the RMS Partnership website. In addition, short video training hints will periodically be posted to the website and freely accessible to all who visit the RMS Partnership website. All course offerings can be tailored or new courses offered based on RMS(L) and systems engineering interest and requirements. Professionals who are interested in developing and teaching courses can contact me at russv@comcast.net.

During the next year the RMS Partnership will be reaching out to other professional organizations, government agencies, and academic institutions to share lessons learned that will benefit the Department of Defense and organizations with which we have a collaborate or partnership relationship. For example, by working closely with transportation and energy professionals we may acquire knowledge and expertise for improving the reliability of defense systems. The converse will also be true. For example, industry, other government agencies, and academia should be able to benefit from the logistics information the Services can provide. Sound RMS (L) and systems engineering principles and practices are common to most disciplines. The RMS Partnership is committed to fostering new relationships and reinforcing existing partnerships to help ensure more reliable, easy to use and maintain, safe and cost effective systems that help keep the U.S. economically competitive and militarily secure.

As the size and the breadth of the RMS Partnership continue to expand and become more diverse so will the composing of the officers and staff of the RMS Partnership. Community members from numerous industry, government and academic disciplines are invited to submit ideas and proposals for new directorships within the RMS Partnership that support and enhance the core mission of the RMS Partnership as mentioned in the opening paragraph of this editorial. For instance, individuals or groups who may be interested in establishing a software tools division can submit a white paper or similar document to me or any director posted on the RMS Partnership website for review and consideration. In addition to meeting Partnership core mission requirements, future directors and divisions are required to maintain an unbiased perspective so that the RMS Partnership reputation as an "honest broker" remains untarnished. Establishing divisions that are related to DOE systems, robotics, and human-computer interaction intensive systems is key to remaining relevant as technology continues to break new boundaries.

The RMS Partnership mission, perspective and membership is expanding while simultaneously endeavoring to ensure RMS(L) requirements are integral to the systems engineering process and throughout the entire life cycle management system. The voluntary and not-for-profit status of the RMS Partnership helps ensure that our activities remain focused on community needs and requirements and not driven by profit or other interests that could interfere with our objectivity and community service. Membership in the RMS Partnership will remain highly cost competitive and professionally beneficial. Your participation and support are invited. Join us in helping us to grow and reshape the RMS Partnership as we improve and expand our service to the RMS(L) and system engineering community. ★

Have you heard there are some exciting changes taking place in the RMS Partnership? It is expanding in depth and breadth to better serve the RMS, logistics and systems engineering community.

Since 1994 the RMS Partnership has served as an "honest broker" for RMS, logistics, and systems engineering matters for industry, government and academia. This role along with its expertise will help build bridges for collaborating and working in partnership with many other disciplines and organizations.

Yes, this is an exciting turn of events. I understand that while keeping true to its core mission, keeping RMS(L) integral to the systems engineering and life cycle process, the Partnership will reach out to other disciplines and organizations to share lessons-learned and leverage expertise.

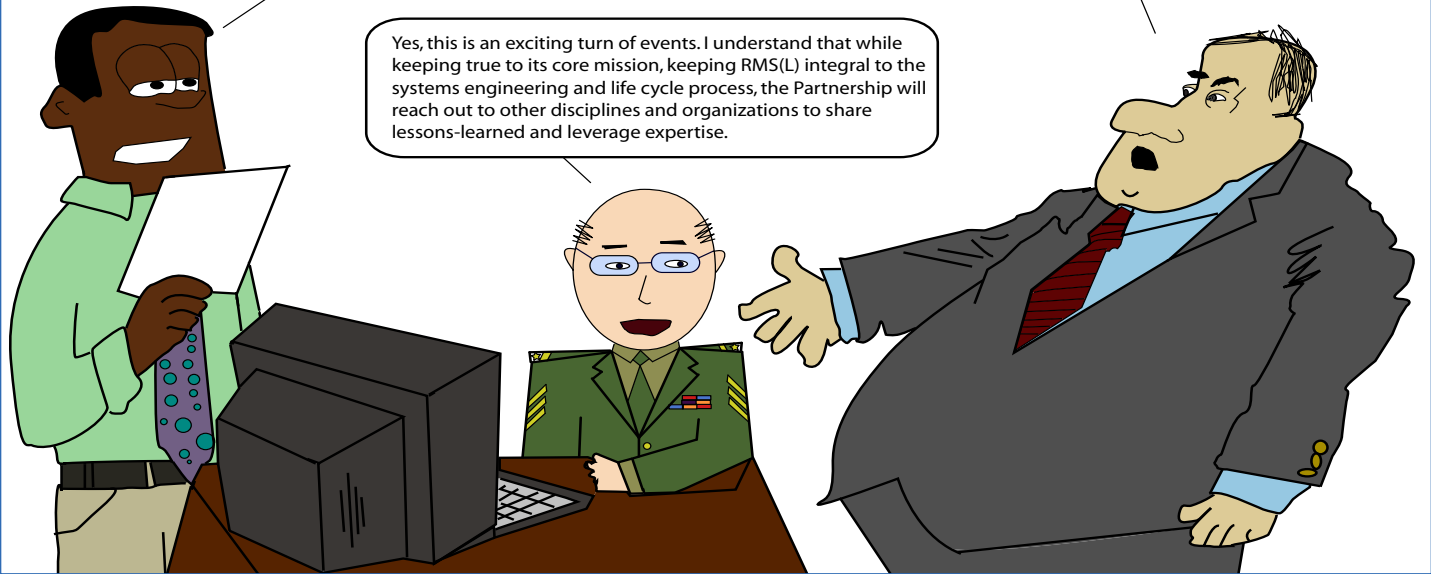

AUTHOR OPPORTUNITIES FOR THE RMS PARTNERSHIP PROFESSIONAL JOURNAL

Contact the Managing Editor: Dr. Russell A. Vacante
russv@comcast.net

RMS ON-SITE SHORT COURSE OFFERINGS!

Provide Us Your Training Requirements & the RMS Partnership will provide tailored training that will exceed your expectations.

For Additional Information contact
Taylor Hughes at t.k.hughes@cox.net

INNOVATIVE TOOLS FOR IMPROVING RELIABILITY, MAINTAINABILITY, SUPPORTABILITY & LOGISTICS IN THE SYSTEMS ENGINEERING PROCESS

Call for Papers, Keynote Speakers, and Panelists for March 2012 Symposium and Workshop in Springfield, Virginia

Interested presenters should contact Dr. Russell Vacante at russv@comcast.net by November 30, 2011 to ensure a time slot for this one-day event

Exhibitors please contact Taylor Hughes by November 30, 2011 for initial space arrangements at t.k.hughes@cox.net

What Simplifying Assumptions Are You Banking On?

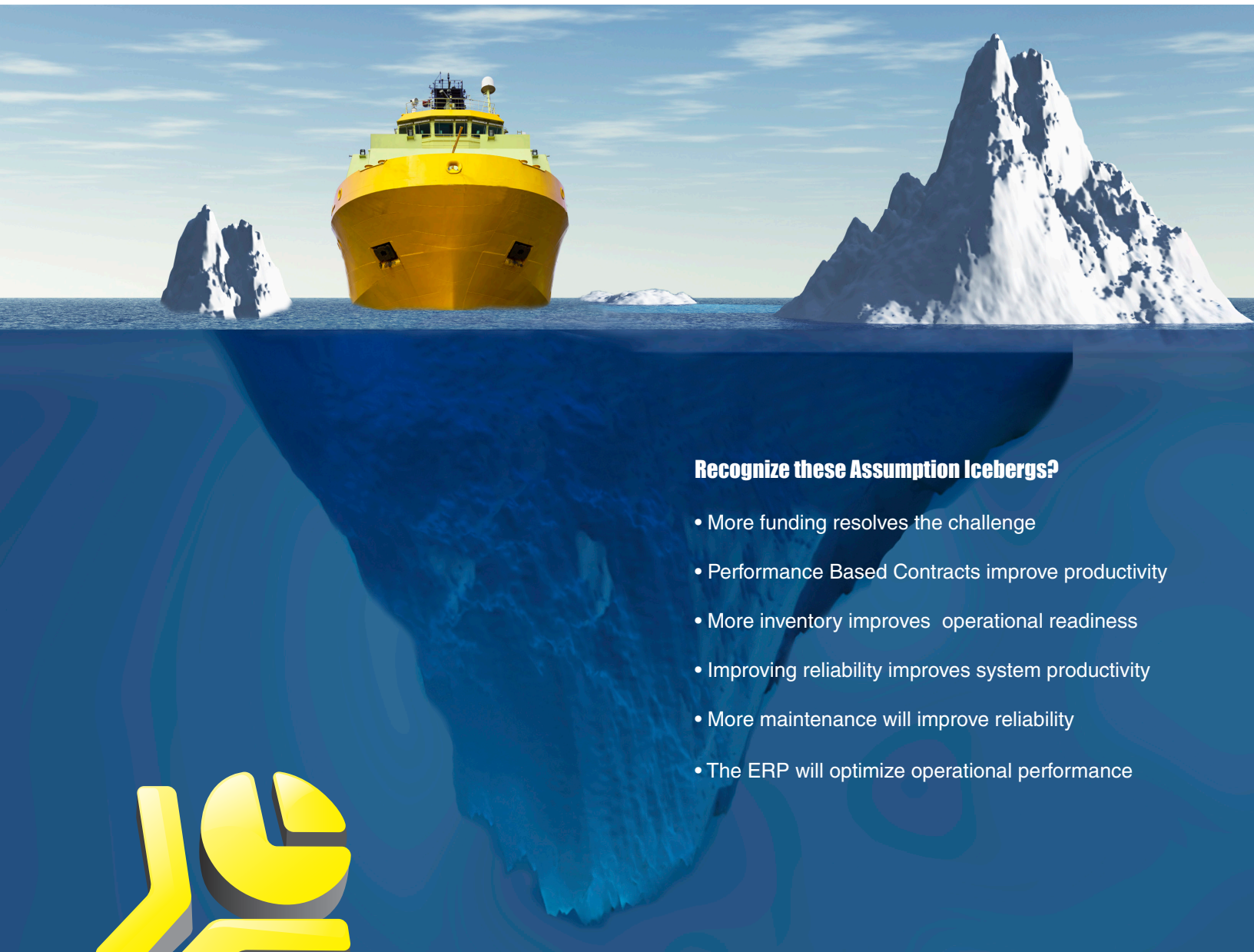

Recognize these Assumption Icebergs?

- More funding resolves the challenge
- Performance Based Contracts improve productivity
- More inventory improves operational readiness
- Improving reliability improves system productivity
- More maintenance will improve reliability
- The ERP will optimize operational performance



RMS Analysis

What type of life cycle analysis “Sonar” mapping do you employ?

Does your “Sonar” have the cross-functional and multi-indentured ability to identify dangerous simplifying assumptions and competing self interests? Does your “Sonar” identify and validate 10 – 100x ROI opportunities in acquisition, reliability, maintainability, and supportability?

Clockwork represents the highest fidelity lifecycle analysis “Sonar”.

Call us + 1-512-338-1945 for a test drive and prepare to see how Clockwork’s technology and people identify cross-functional lifecycle demands, risks, costs, and operational productivity like no one else.

clockwork-solutions.com

Master of Science Systems Engineering

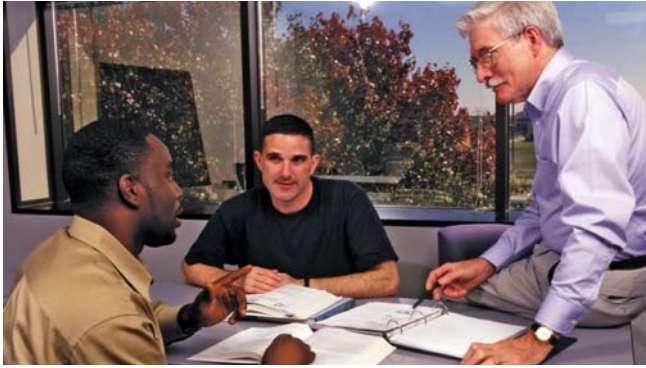

SMU's Systems Engineering Program is dedicated to the branch of engineering that develops systems – a collection of elements working together as a unit. Applied to large units such as power plants or to small components such as circuits... to hardware or software...to tangible products like automobiles or intangible products like services or processes, systems engineering focuses on the total life cycle: concept, design, use, maintenance, and end-of-life.

Through related topics in this 30-hour program, students gain exposure to reliability, quality, logistics/supply webs, operations research, engineering management, software engineering, telecommunications and environmental engineering. They are encouraged to practice “good engineering” and to look at the big picture as opposed to focusing only on details.

Using “systems thinking” skills to better understand the impact of their engineering decisions and the impact of other decisions upon them, students learn to develop engineering and management skills, applying these skills within the business environment to exceed customer requirements.

Admission Requirements

- Bachelor of Science in engineering,* mathematics, or one of the quantitative sciences.
- G.P.A. of at least 3.00 out of 4.00 scale in previous undergraduate and graduate study.
- A minimum of two years of college-level mathematics, including at least one year of calculus.

*A Bachelor of Science in an appropriate engineering discipline is required for the System Engineering and Design track.

For more information, please email
EngineeringLeaders@smu.edu,
call 214-768-2002 or visit lyle.smu.edu.

Degree Requirements

Thirty term-credit hours (30 TCH) of graduate courses with a minimum graduate G.P.A. of 3.00 on a 4.00 scale.

Satisfactory completion of the five core curriculum courses (15 TCH)

- Systems Analysis Methods
- Systems Engineering Process
- Integrated Risk Management
- Systems Reliability, Supportability, and Availability Analysis
- Systems Integration and Test

AND Satisfactory completion of one (1) of the following tracks

Systems Engineering Technology Track (15 TCH)

- Systems Engineering Design
- Software Systems Engineering
- Systems Engineering Leadership
- Systems Reliability Engineering
- Logistics Systems Engineering

System Engineering and Design Track (15 TCH)

- Introduction to Numerical Analysis
- Introduction to Telecommunications
- Analog and Digital Control Systems
- Systems Analysis
- Communication and Information Systems
- Digital Image Processing
- Advanced Thermodynamics
- Vibration Analysis of Electronic Systems
- Multivariable Control System Design

Logistics and Supply-Chain-Management Track (15 TCH)

- Systems Reliability Engineering
- Logistics Systems Engineering
- Production and Operations Management plus any two (2) of the following courses:
- Statistical Quality Control
- Reliability Engineering
- Operations Research Models
- Economic Decision Analysis
- Optimization Models for Decision Support

Systems Engineering Application Track (15 TCH). Satisfactory completion of electives approved from available graduate-level concentrations within one of the Lyle School of Engineering departments listed below. Concentration must be in a different field from the undergraduate major.

- Computer Science and Engineering
- Electrical Engineering
- Engineering Management, Information, and Systems
- Civil and Environmental Engineering
- Mechanical Engineering