

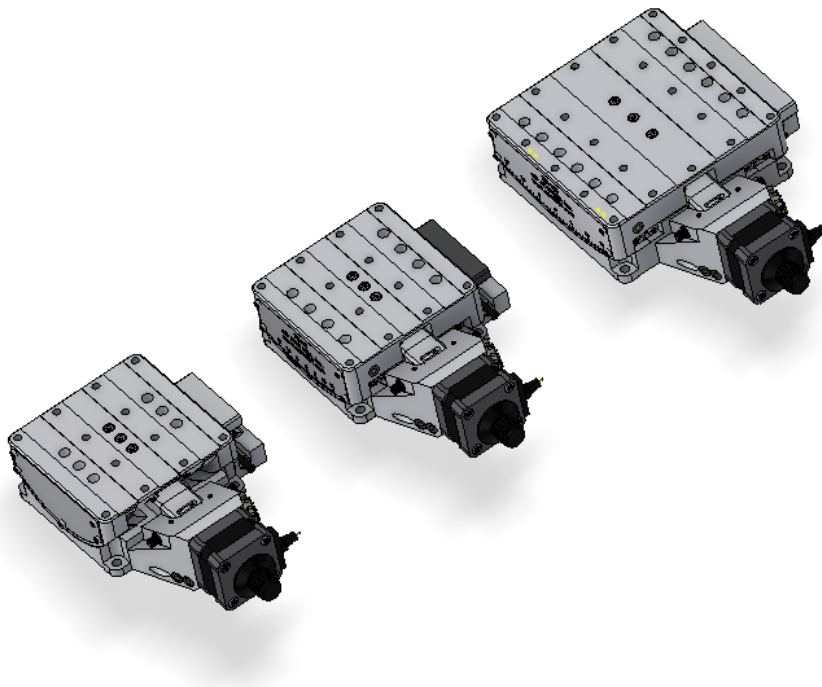

High Precision Light Duty Tilt Stages

TS Series



August 2023



SPECIFICATIONS

The TS-LD Series tilt stage(s) provide a rigid, accurate motion for general goniometric use. The TS-LD Series is stepper motor driven, guided with curved linear bearings, and has a rugged anodized aluminum body. The top and bottom mounting surfaces are precision ground to provide an optimal interface. The TS-LD Series uses curved crossed roller bearings for the highest possible rigidity and profiled trajectory. The drive mechanism is a precision ground worm wheel segment and stepper motor driven worm.

MECHANICAL

Specification	TS50	TS90	TS160
Travel Range (°)	+/-10	+/-10	+/-10
Gear Reduction	360:1	360:1	360:1
Repeatability (μrad RMS)	280	280	160
Trajectory Straightness (μm/25mm)	5	5	5
Runout (μm)	3	3	15
Full Step Resolution (μrad)	26	28	27
Load Capacity (kg)	6	12	20

ELECTRICAL

Motor	Limit Switches	Optical Encoder
2-Phase; 5-Phase Stepper; DC	Mechanical, Normally Closed	Renishaw Incremental or Absolute (http://www.renishaw.com)

LOAD CHARACTERISTICS

Stage	F (N)*	M (Nm)
TS-50	964	3
TS-90	3700	7
TS-160	5260	14.5

*For eccentric maximum load, contact AVS|US engineering.

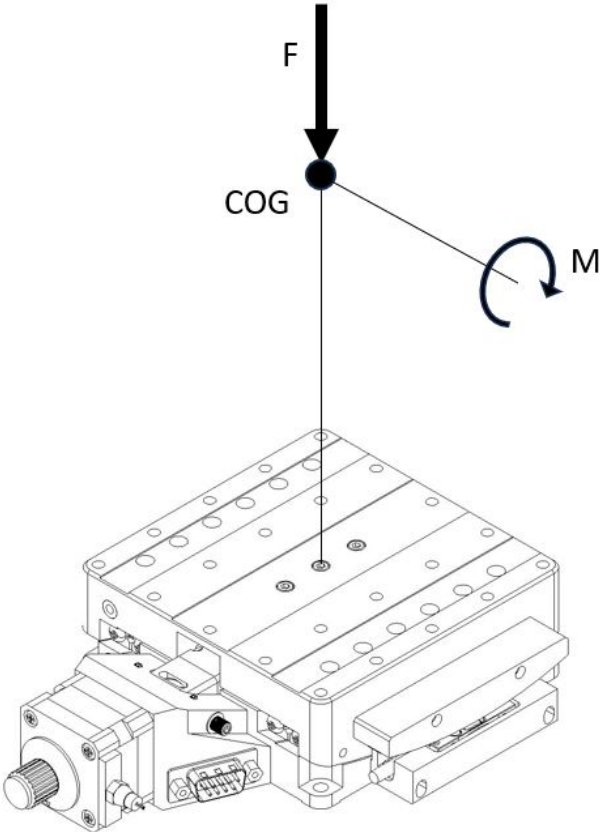

*COG, center of rotation

DIMENSIONS

Top View

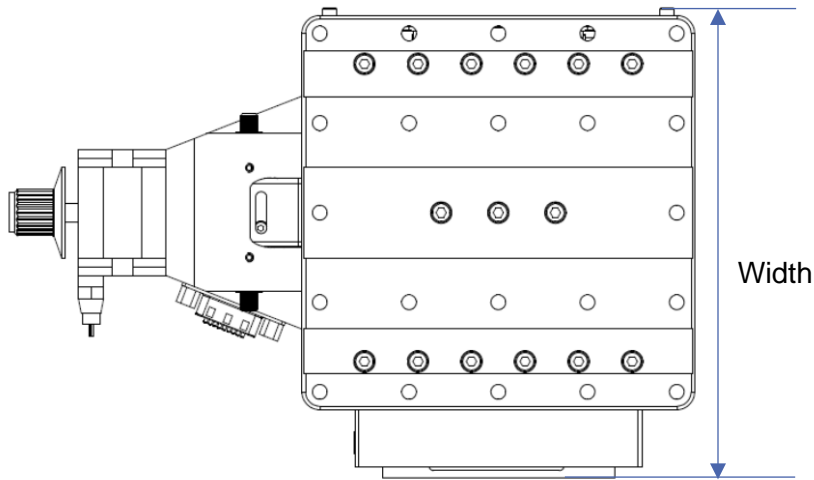

Side View

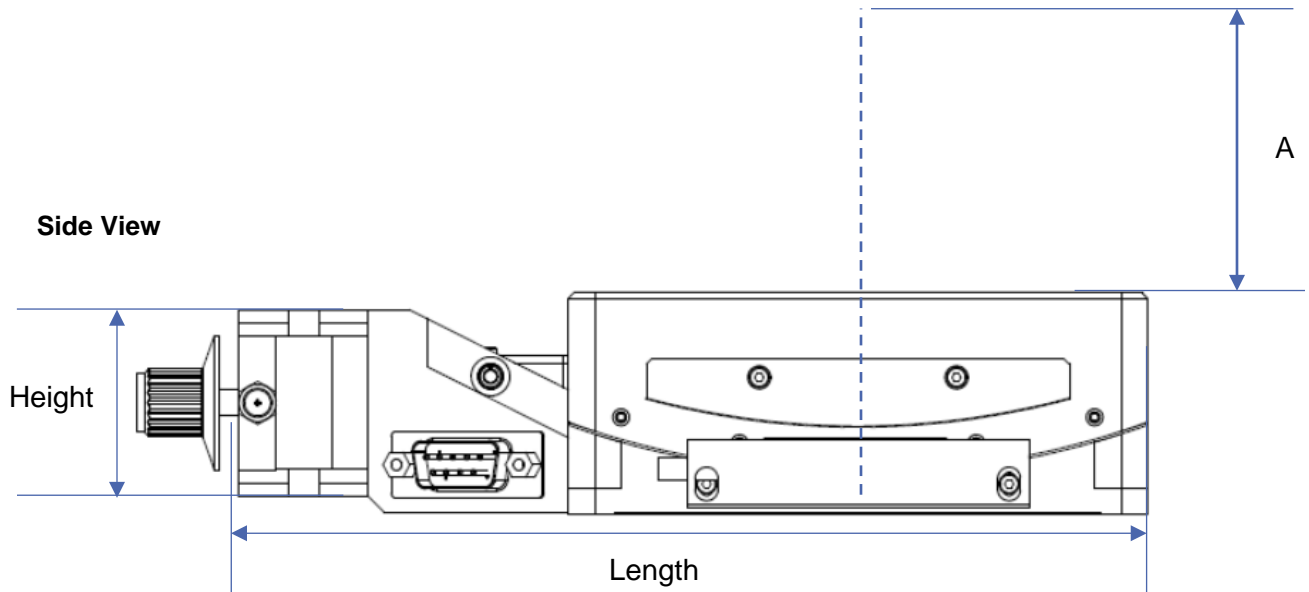

(mm)	Length	Width	Height	A, COG	Mounting Surface	Curvature of Rails
TS-50	170	87	41	18	85x85	50
TS-90	170	106	40	59	85x85	90
TS-160	192	112	42	130	110x110	160

ORDERING INFORMATION

Tilt Stages can be ordered with different configurations. Please use the codes provided below when ordering. Please call or e-mail to ask about any other customization required.

TS-HD (Heavy Duty Tilt Stage)	TS-50	TS-90	TS-160
Air Preparation Options	-A (Standard Air Stage) -V (Vacuum Stage; ask about options when placing order)		
Encoder Options	-R (With Incremental Optical Encoder) -A (With Absolute Optical Encoder) -N (Without Encoder)		
Brake Options	-B (With Brake, 24VDC) -N (Without Brake)		
Motor Options	-2PH (Standard 2 Phase Bi-Polar Stepper Motor) -5PH (5 Phase Stepper Motor) -DC (DC Motor)		
Gearbox Option	-G (customer to enter desired ratio; 3:1 to 100:1 available)		

Example Order:

TS90-A-N-N-2PH

This is an order for a TS50 Precision Goniometer in air, no encoder, no brake, and a 2-phase motor, no gearbox.

OTHER STAGES

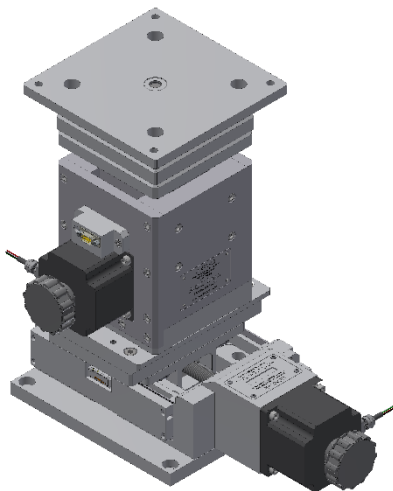
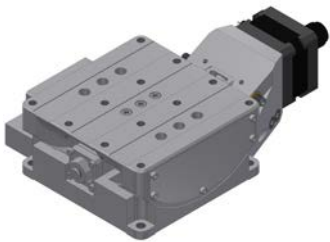

Linear Stages	Lift Stages
DS210	DJ210
DS310	DJ310
DS410	DJ410
DS510	BJ10
	BJ25
Tilt Stages/ Goniometers	Rotation Stages
TS-50	RS-100
TS-90	RS-200
TS-160	RS-300
TS-300	RS-400
TS-400	RS-500
TS-565	
TS-700	

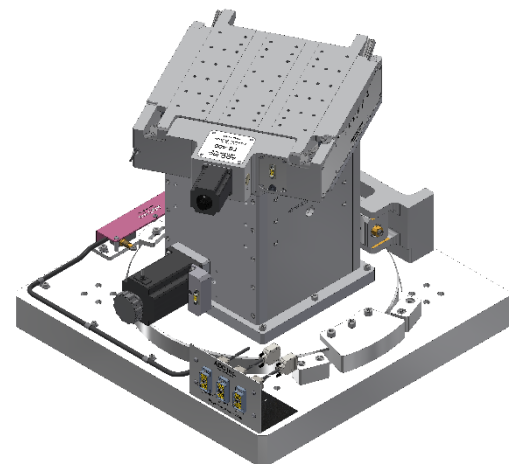
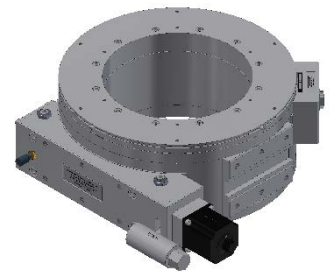
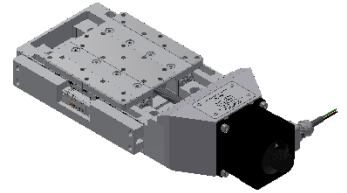

CONTACT US



QVS

Pol. Ind. Sigma, Xixilion kalea 2, Bajo,
Pabellón 10
20870 Elgoibar, Gipuzkoa, SPAIN
T +34 943 821 841
F +34 943 821 842
avs@a-v-s.es

QVS | UK

Rutherford Appleton Laboratory
Harwell Campus
OX11 0QX Didcot, Oxfordshire, UK
T +44 (0) 1235 567095
avs@a-v-s.uk

QVS | US

126 Ridge Rd
Lansing, NY 14882, USA
T +1 607 533 3531
F +1 607 533 3618
avsus@a-v-s.us

UFG

Westcott Venture Park
Aylesbury HP18 0XB
Buckinghamshire, UK
T +44 (0) 1235 567095
agarbayo@a-v-s.uk



Parque Empresarial Tactica
Calle Velluters 17
46988 Paterna, Valencia, SPAIN
T +34 961 344 831
F +34 961 344 830
comercial@vacuum-projects.net

SCIENTIFICA

Pol. Ind. Sigma, Xixilion kalea 2, Bajo,
Pabellón 10
20870 Elgoibar, Gipuzkoa, SPAIN
T +34 943 127 285
scientifica@scientifica.es

126 Ridge Rd, Lansing NY, 14882

www.a-v-s.us / www.adc9001.com

1-607-533-3531

avsus@a-v-s.us
