



WB-3000

Work bench designed specifically for welding operations.

- Eliminates moving extraction arms over the welding zone
- Meets ACGIH guidelines for capturing weld fume—150 fpm minimum capture velocity through the breathing zone
- Provides a cleaner work environment for maximum productivity
- Hinged side-wing panels accommodate longer workpieces
- Ergonomically designed for operator comfort
- Easy filter maintenance from clean air side makes filter changeout quick and efficient
- Standard Ultra-Web® FR cartridges, with nanofiber technology, provide higher filtration efficiency and longer filter life
- MERV* 13 filtration efficiency rating per ASHRAE 52.2-2007
- Helps support OSHA Clean Air Standards
- Quiet operation

DIMENSIONS & SPECIFICATIONS

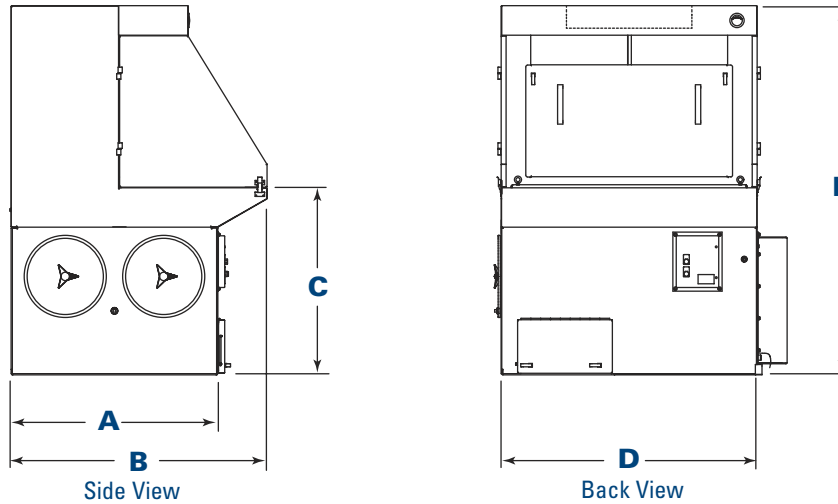

Model	Nominal Airflow**		Motor (hp)	Backdraft		Dimensions										Dust Capacity		Max Load per sq. ft.		Shipping Weight		Sound Level dB(A)†
	cfm	m³/h		fpm	m/min	A	B	C	D	E	ft³	m³	lb	kg	lb	kg						
WB-2000	2000	3397	3	150	45.7	42.0	1066.8	52.0	1320.8	38.0	965.2	52.0	1320.8	75.0	1905.0	1.4	0.04	150	68.0	1214	550.7	68
WB-3000	3000	5096	5	150	45.7	42.0	1066.8	52.0	1320.8	38.0	965.2	78.0	1981.2	75.0	1905.0	2.8	0.08	150	68.0	1575	714.4	72

Note: Customer must have 90 to 100 psi clean air available.

STANDARD FEATURES & AVAILABLE OPTIONS

STANDARD	OPTIONAL
7-gauge heavy-duty work surface supports 150 lbs/ft² (732.4 kg/m²)	Prewired controls with after-shift cleaning system
Automatic self-cleaning pulse jet system	IEC disconnect
150 fpm (45.7 m/min) backdraft velocity	* The Minimum Efficiency Reporting Value (MERV) of this filter cartridge has been determined through independent laboratory testing using ASHRAE 52.2 (2007) test standards. The MERV rating was determined at a face velocity of 118 feet per minute (36.0 meters per minute) and loading up to four inches (101.6 millimeters) water gauge. Actual efficiency of any filter cartridge will vary according to the specific application parameters. Dust concentration, airflow, particle characteristics, and pulse cleaning methods all affect filtration efficiency. ** Based on clean filters. † Sound level per ANSI S12.34,1988. The actual measured sound level will vary, depending on background noise and room conditions.
Quiet, efficient airfoil fan	
Large capacity dust drawers	
Ultra-Web® FR cartridge	
Pneumatic tool connection	
Sprinkler head	
10-year warranty	

Significantly improve the performance of your collector with genuine Donaldson Torit replacement filters and parts. **Call Donaldson Torit today 800-365-1331.**



Tel 800-365-1331 (USA)
Tel 800-343-3639 (within Mexico)

donaldsontorit@donaldson.com
donaldsontorit.com

Donaldson Company, Inc.
Torit
P.O. Box 1299
Minneapolis, MN
55440-1299 U.S.A.

EXACTLY WHAT YOU NEED.™

Weld Bench Fume Collector (11/12)
© 2000 Donaldson Co., Inc. All Rights Reserved. All products, product specifications, and data (airflow, capacity, dimensions, or availability) are subject to change without notice, and may vary by region or country. Donaldson Torit and Ultra-Web are registered trademarks of Donaldson Company, Inc. Contains Donaldson proprietary technology.