

Internal faults of power transformer diagnosis by using dissolved gas analysis (DGA) with fuzzy logic Method.

Mr.Rahul M. Palke, Mrs. Pragati korde
GHRIET, Savitribai Phule Pune University,Pune, Maharashtra
rahul.37.2000@gmail.com

Abstract-Electricity distribution is not possible without the transformer and hence it becomes integral part of power system. Normal working ensures reliability of power supply. Transformer monitoring and inspection should be carried out at regular intervals to avoid the internal faults in power transformer. Failure results huge loss in the economy of the distribution sector. So many conventional techniques are developed to diagnosis of power transformer and all are relies on the expert's opinion. There may be possibility of error in the interpretation of various tests.

This paper contents the fuzzy logic tool developed to show the exact stage of internal fault in the transformer. The electrical, mechanical and thermal faults are recorded existing in the transformer. It utilizes the test data of Dissolved Gas Analysis (DGA), SFRA (Sweep frequency response analysis) and Total Dissolved Gas Analysis (TDCG) to reduce the misinterpretation. It also shows the existing conditions of partial discharge, oil thermal, electrical arc, Break down Voltage (BDV), mechanical deformation of core and winding. This system has eleven fuzzy logic controllers and are arranged to connect as per technical conditions. It results in highly precise to identify the situation of transformer and identify the existing condition. DGA data of 33/11 KV Wada Substation 10 MVA transformer (Pune District, Maharashtra, India) is used.

Keywords: - Transformer, fuzzy logic controllers, faults, membership function.

I. INTRODUCTION

Power transformer is important part of power system and it requires the regular maintenance with monitoring techniques and tools are yet having some challenges in the monitoring of transformers. Dissolved gas analysis is the most useful technique in analysing the technical condition of power transformer. The Key Gas method [1], Duval triangle method [2], Roger ratio method [3-4] are the major interpretation technique. All methods are having one problem that they depend on expert opinion rather than mathematical calculation. DGA to describe the issue as translated esteems are out of standard extent.

DGA discovers its disappointment rank and effects on its ageing. Particular gases are generated with decreasing capacity of protecting oil and paper during fault. Paper decay developed the carbon monoxide (CO) and carbon Dioxide (Co2) and oil disintegration delivers the Hydrogen (H2), Methane (CH4), Acetylene (C2H2), Ethylene(C2H4) and Ethane (C2H6) [6]. Co and CO2 are advanced because

of paper debasement flaws. Ethylene (C2H4) and Ethane(C2H6) are related to increase in temperature of oil and partial discharge produces (H2), methane (CH4) and arcing produces Acetylene(C2H2)and Hydrogen (H2)[6] also BDV is used to determine the dielectric strength of oil. It indicates the degradation of oil. Internal failures related to thermal faults are divided in to oil thermal fault and paper thermal fault and similarly electrical faults are divided in to P.D electrical faults and arcing faults. Fig.1 shows classification of internal faults of power transformer.

Mechanical faults are also contributing internal faults. This outcomes to extreme misfortunes to the transformer. Mechanical faults, for example winding and core faults can be recognized by sweep frequency response analysis (SFRA).

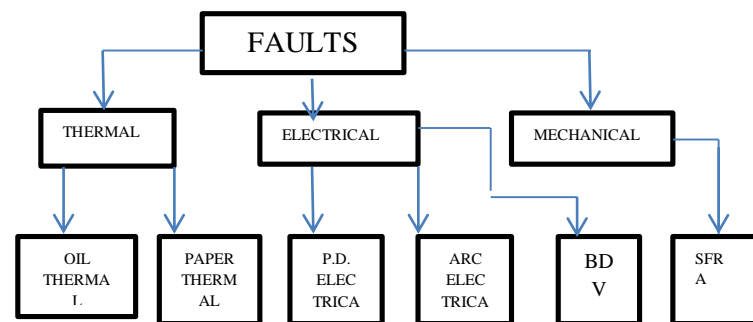

Fig.1 Faults Classification.

In this paper overall criticality of transformer is calculated by developing new fuzzy logic based system. it uses test data of DGA, BDV and SFRA values as inputs. In MATLAB repeating sequence blocks are used to provide inputs. BDV, DGA are acquired from test outcome. SFRA is utilized on the assessment curve got subtracting the present and reference frequency response curve.

II. FUZZY LOGIC ALGORITHM

Fig.2 shows Typical Fuzzy Logic System. It explains how the relation between input variables and output variable given by knowledge processing is used for fuzzification and defuzzification.

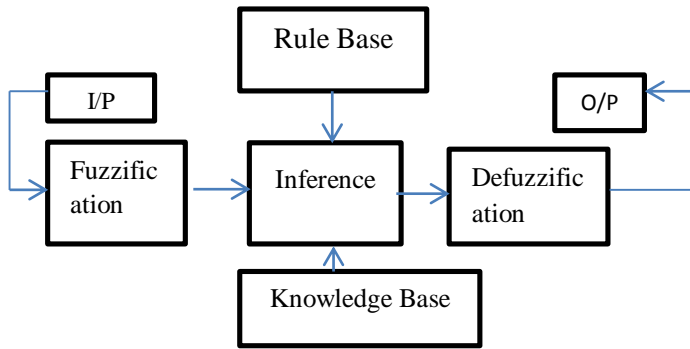

Fig.2:- Typical Fuzzy Logic System

After defuzzification and calculation of centroid output is calculated. fuzzy logic system is used for

The variables are logically combined (AND, OR, NOT operations) in knowledge processing unit. After defuzzification the output is calculated. By using the level of uncertainty namely normal, low, moderate, high, and critical fuzzy logic approach is used for classification of data.

Controllers are designed by using FIS with the help of MATLAB. All membership function (I/P and O/P) trapezoidal function considering the particular ranges and with the help of this rule base is developed to differentiate the classification of criticality level of each parameter. Set of rule is used to define correlation between input and output variables and for this conditional statements IF, THEN, AND utilized in knowledge base to represent the fuzzy logic controllers. Model of fuzzy logic controllers uses “MAMDANI FUZZY INFERENCE SYSTEM” below fig.3 shows the eleven fuzzy logic controllers. It comprises of six fuzzy logic controllers (pink colour) and eleven inputs are supplied to six fuzzy logic controllers. At intermediate stage there are four fuzzy logic controllers (two orange and two blue coloured) and one at output side (Dark blue coloured). This model gives information about the present criticalities of transformers like BDV, DGA, SFRA, paper thermal, oil thermal, P.D. electrical, Arc electrical. Hence overall criticalities of transformer can be easily obtained. One fuzzy logic sub controller is described in detail and same process is utilized for remaining sub fuzzy logic controllers. BDV, DGA, SFRA criticalities are explained separately in details as per the rule base defined to them.

A. SUB FUZZY LOGIC CONTROLLER

In power transformer insulating paper is heated, its temperature rises and it starts to losing its heat dissipating strength and simultaneously release of CO and CO₂ gases occurs. It defines the paper thermal criticality in transformer. Fuzzy logic controller is used to define the existing stage of paper thermal criticality in transformer. Ranges are defined 0-1000 ppm for CO and 0-15000 for CO₂. Values of CO and CO₂ are applied to sub fuzzy logic controller. Rule bases are presented to controllers, after simulation it shows the present criticality of

transformer. In developing this fuzzy logic model trapezoidal membership functions are used. Input and output functions are shown in fig 5,6 and 7. In MATLAB/GUI for FIS input are read as per their rule bases defined whereas output membership function are calculated on the 0-1 scale range to classify its range from DGA test this sub fuzzy logic controller is supplied with interpreted data from DGA test CO₂=3120,CO=191 rules were defined earlier which can be viewed in rule viewer plot.

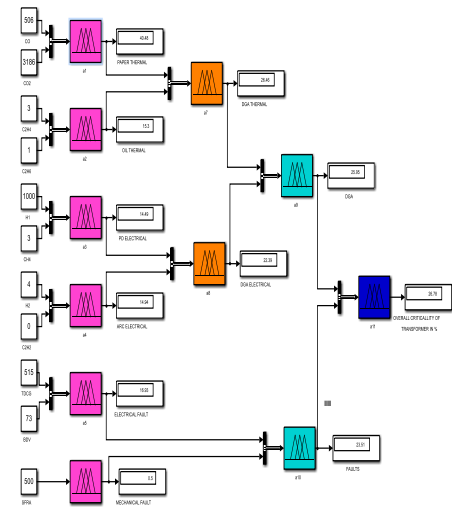

Fig.3 Complete FLC model for overall criticality of transformer.

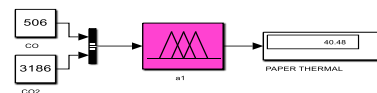

Fig.4 Sub Fuzzy logic controller model of paper thermal criticality

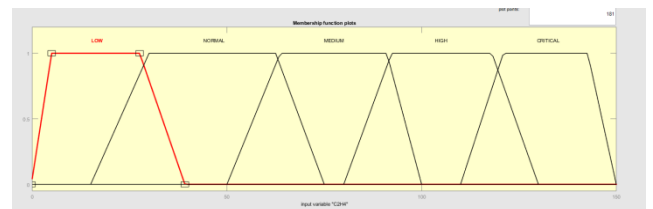

Fig.5 Figure.5 I/P Membership function plot of CO

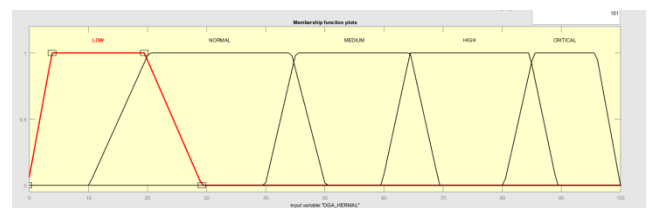

Fig.6 I/P Membership function plot of CO₂

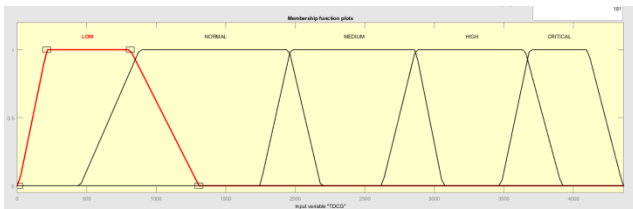

Figure.7 O/P Membership function plot of paper thermal criticality.

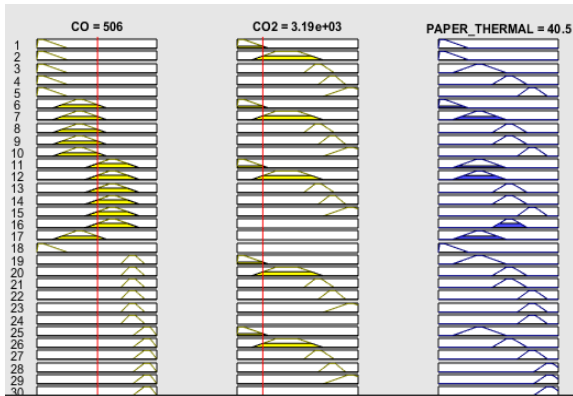

Fig.8 Rule viewer of paper thermal criticality

B. DGA CRITICALITY

DGA is done for transformer and obtained result values are applied to the fuzzy logic controller input constant blocks. Input variables are defined on various scale ranges are as follows. Ethylene (C₂H₄)-0-150 ppm, ethane (C₂H₆)-0-35 ppm, carbon monoxide-(CO)- 0-100 ppm, carbon dioxide (CO₂)- 0-15000ppm, Hydrogen (H₂)-0-1000 ppm, methane (CH₄)-0-80 ppm, acetylene (C₂H₂)-0-70 ppm, whereas output membership function are defined on the scale 0-1 to describe level of criticality as per the standard IEC-599. First two sub fuzzy logic controller output membership function gives the paper thermal and oil thermal criticality. After integration of these two we get DGA thermal criticality. Third and fourth sub fuzzy logic controller gives the electrical criticality and arc electrical criticality, afterwards the integration of DGA electrical and DGA thermal gives output as a DGA criticality.

C. BDV CRITICALITY

Values of breakdown voltage of transformer oil is calculated and applied as input to the fifth sub fuzzy logic controller input membership function scale defined for the variable is 0-40 KW. Output of this sub fuzzy logic controller is BDV criticality in %. Which is defined on the scale of range from 0-100% as per the ASTM-877 standard scale is defined.

D. SFRA CRITICALITY

Internal deformation in transformer core and winding are calculated by SFRA. It depends upon the curve obtained

on subtraction of present and reference frequency response. Difference is measured in frequency ranges no deformation are 0 KHz, whereas 0-5 KHz shows core is twisted, 1-10 KHz difference indicates the winding deformation, 5-500 KHz difference shows radial deformation and frequency difference greater than 400 KHz represent axial deformation. Scales are as per the experts opinions. Classifications of criticalities are based upon the ranges of frequencies. Scale of output membership function is defined on 0-100% to find out SFRA criticality.

III. TRANSFORMER OVERALL CRITICALITY

Transformer overall criticality is found out by integrating the overall criticalities of BDV, SFRA, TDCG, and DGA. For this criticality output and input membership function are defined on ranges of scale 0-100% differentiate the criticality level. Rule base is decided to develop the correlation between input and output functions and is shown in fig. 9

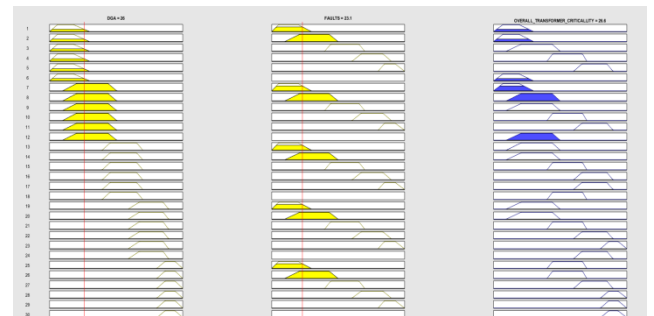

Fig.9 Rule viewer for Overall criticality of Transformer

SIMULATED MODEL TESTING: A CASE STUDY

Fuzzy logic model is tested for various test results and accordingly criticality of each unit of simulated model is obtained. This model shows results of criticalities of SFRA, BDV, DGA, Thermal, P.D. electrical, arcing electrical and are matching with the result of conventional interpreting techniques with much more preciseness. A transformer of 5 MVA, 33/11 KV Wada Substation, Pune, Maharashtra state is manufactured in the year 2002 has been tested on 29 September 2019. This transformer is tested for BDV, SFRA, and DGA. As per the data of SFRA no mechanical deformation is observed. Ranges of BDV is 46.3 KV (as per IS-1866/2000)also DGA interpretation is as per the IS-10593/1992). Water Content in oil is 41 (ppm) which is quite dangerous and Acetylene obtained value is 30 (ppm) it also indicates the internal short circuit possibility. CO and CO₂ gases values are in normal range, hence it is observed that insulating oil is normally heated. DGA, SFRA, BDV test data when supplied to simulated model criticality values are obtained as below.

- a. Oil thermal criticality: 15.3%
- b. Paper thermal criticality: 28.16 %
- c. DGA thermal criticality: 26.79 %
- d. P.D electrical criticality: 14.61 %
- e. Arcing electrical criticality: 66.21 %

- f. DGA electrical criticality: 45.16 %
- g. DGA criticality: 38.76%
- h. Overall transformer criticality: 25.81 %

As per above result, it is found that, insulating oil needs to be replaced and paper are normally heated with criticality values 28.16 % and overall transformer criticality is found 25.81 %. From this we can say that transformer is required to take offline and needs to be inspected internally. Also attention should be on the cooling methodologies and loading conditions.

The model is tested for one sample of oils with diagnosed test results of one test as inputs which are shown in TABLE I and the corresponding results were tabulated in TABLE II.

IV CONCLUSION

This Fuzzy logic model is made to discriminate the damage of attack on transformer in the topology of being attacked from normal to critical in précised manner. Technologist may not be able to take decision easily due to abnormal environmental conditions, as test result varies in large scale for a very short duration of time. This model is developed to diagnose the fault of power transformer related to thermal, electrical and mechanical. Which are investigated by DGA, BDV and SFRA diagnostic tool. This model plays important role to detect the transformer internal fault in more précised manner without involvement of expert for interpretation

Table:-I Input To the fuzzy logic Controller

Dissolved Gases	CO2	C2H4	C2H2	C2H6	H2
Obtained Values(ppm)	3120	3	30	1	15

O2	N2	CH4	CO	H1	TDCG	BDV
7440	19900	2	191	15	241	46.3

Table:-II Output Criticality values in percentage of Power transformer as per above table-I.

Paper thermal	Oil Thermal	PD Electrical	ARC Electrical	Electrical Fault
28.16	15.3	14.61	66.21	14.46

Mechanical Fault	DGA Thermal	DGA Electrical	DGA	Faults
0.5	24.79	45.16	38.76	21.45

Overall Criticalty
25.81

REFERENCES.

- [1] IEC Publication 60599: 'Interpretation of the analysis of gases in transformers and other oil-filled electrical equipment in service', 2014
- [2] "IEEE guide for the interpretation of gases generated in oil-immersed transformers," IEEE Std C57.104-2008
- [3] (Revision of IEEE Std C57.104-1991), pp. C1-27, 2009.
- [4] M. Duval, "New techniques for dissolved gas-in-oil analysis, Electrical Insulation Magazine, IEEE, vol. 19, pp. 6-15, 2003.

- [5] V. G. Arakelian, "Effective diagnostics for oil-filled equipment," Electrical Insulation Magazine, IEEE, vol. 18, pp. 26-38,2002.
- [6] R. R. Rogers, "IEEE and IEC Codes to Interpret Incipient Faults in Transformers, Using Gas in Oil Analysis,"
- [7] Electrical Insulation, IEEE Transactions on, vol. EI-13, pp. 349-354,
- [8] J. M. Mendel, "Fuzzy Logic Systems for Engineering: A Tutorial", Proc. IEEE, Vol. 83, pp. 345-377, 1995.



Author is Student of Second year ME (Power System), GHRIET, SPPU Pune. His area of interest is Power transformer behaviour and its internal faults.