INSTALLATION AND OPERATIONAL MAINTENANCE MANUAL

IN ROW NANO SYSTEMS CKC AYAN IV-IR NANO SERIES



IN ROW COOLING

COMPU-AIRE, INC.

8176 BYRON ROAD, WHITTIER, CA 90606

PHONE: (562) 945-8971

FAX: (562) 696-0724

Website: www.compu-aire.com

Email: cs@compu-aire.com

ISO 9001-2008 REGISTERED COMPANY

TABLE OF CONTENTS

SAFETY INSTRUCTIONS	3
GENERAL	4
TRANSPORTATION MODE	4
IMPORTANT – READ BEFORE INSTALLING	5
LOCATING THE UNIT	5
ELECTRICAL DATA:	5
NAMEPLATE DATA	5
CONDENSATE DRAINS	6
CONDENSATE PUMP	6
IMPORTANT SUGGESTION*	6
ABOUT COMPU-KOOL - AYAN IV SERIES	6
TECHNICAL DATA	7
INSTALLATION	8
UTILITY CONNECTIONS	8
AIR FLOW	8
CONNECTIONS	8
STRUCTURAL SUPPORT	8
ELECTRICAL SUPPORT	9
CONDENSATE DRAIN CONNECTION	9
WATER CONNECTIONS	9
REFERENCE	17

TABLE OF FIGURES

Figure 1 - System layout	10
Figure 2 – General wiring diagram	11
Figure 3 - Ayan iv inrow cooling	12
Figure 4 - Front view	12
Figure 5 - Back view	13
Figure 6 - Control Panel	13

SAFETY INSTRUCTIONS

Only qualified personnel should install and service this equipment. The installation, start-up, and servicing of heating, ventilating, and air conditioning equipment can be hazardous and requires specific knowledge and training. Improperly installed, adjusted or altered equipment by unqualified personnel could result in serious damage and/or death. When working on the equipment, observe all precautions in this literature and on the tags, stickers, and labels that are attached to the equipment as well as all local codes and safety requirements.

This user's manual contains important safety instructions that should be followed to properly install and maintain Compu-Aire system Compu Kool Chilled Water Ayan IV In Row Nano series. Read this manual thoroughly before attempting to install or operate this unit. Store this manual at safe place for future reference.

Adhere to all warnings, cautions and safety instructions on the unit and in this manual. Follow all local codes and safety requirements to install and service this unit.



WARNING

Installation and service of this equipment should be done by qualified personnel who have been specially trained and qualified in the installation of specific HVAC equipment. Improper installation could result in unaccountable loss or damage. Compu Kool Chilled Water In Row Nano series equipment requires a permanent power connection from an isolated circuit breaker. Customer must provide earth ground to the unit per NEC, CEC and local codes as applicable.

- Risk of high speed moving parts can cause injury or death.
- Risk of heavy unit falling over
- Risk of hot surfaces, sharp edges, splinters and exposed fasteners can cause injury



WARNING

High voltage danger!
Arc flash and electric shock hazard.

Disconnect main power supply from the feeder before working on this unit. Proceed with caution and always wear protective equipment per NFPA 70E before working within electrical control panel. Failure to comply can cause serious injury or death.



WARNING

Evaporator unit requires drain connections and water supply.
Do not locate these connections above any equipment that could sustain water damage.

NOTICE

- Improper storage can cause unit damage. Keep the unit upright and store it indoor. Protect the unit from dampness, freezing temperatures and contact damage.
- Risk of overhead interference. The unit may be too tall to fit through a doorway. Measure the unit and doorway heights and follow the installation plans to verify clearances prior to moving the unit.
- Risk of clogged or leaking drain lines. Drain line must be inspected and maintained to ensure that drain water runs freely through the drain system. Improper installation, application and service practices can result in water leakage from the unit. Water leakage can cause severe property damage and loss of critical data center equipment. Suitable leak detection system shall be installed for the unit and water supply lines to minimize the damage.
- Risk of leaking unit coil/or piping due to freezing and/or corrosion can cause equipment and building damage. Use proper antifreeze and inhibitors to prevent freezing and premature coil corrosion. If required, the water or water/glycol solution shall be analyzed every six months to determine the pattern of inhibitor depletion.

GENERAL

The Compu-Aire Compu-Kool Ayan IV In Row Nano series is a complete environmental control system, factory wired, tested, and specially designed to provide temperature, humidity, and dust control for computer room installations.

The unit as shipped from the factory includes a EC fan or blower/motor package, evaporator with expansion valves, co-axial condensers, water control valve, and humidifier, reheat elements, electrical control package, control monitor, and other specified special options.

The Ayan iV In Row Nano series captures high temperature air from the rear of the equipment (hot aisle) and discharges conditioned air from the front of the equipment (cold aisle). All service access is from the front or rear of the equipment. Operator controls are located on the front of the equipment. The equipment comes completely factory assembled, piped, and wired.

TRANSPORTATION MODE

Visual inspection of the outer casing provides a simple indication of possible internal damage to the equipment. Move the unit to the installation site in the upright position. **FILE A CLAIM WITH THE SHIPPING COMPANY IF THE SHIPMENT IS DAMAGED OR INCOMPLETE. FREIGHT DAMAGE CLAIMS ARE THE RESPONSIBILITY OF THE RECEIVER.**

Optional articles such as jack stand parts, condensate pump, and remote control panel are packed inside the unit.

IMPORTANT – READ BEFORE INSTALLING

Check the power supply. Voltage, frequency and phase must correspond to that specified on the unit nameplate. The power supply must be able to handle the additional load imposed by this equipment.

LOCATING THE UNIT

Consult local building codes and National Code for special installation requirements. When installing the unit, allow sufficient space for air flow clearance, wiring and servicing the unit.

Front and rear of the unit should have a minimum clearance of 36 inches for servicing.



The unit you have received is very special. It is specifically designed for Computer Room applications. Please read the following INSTRUCTIONS prior to working on the equipment.

ELECTRICAL DATA:

208v, 3 phase, 60 Hz, 460v, 3 phase, 60 Hz, 208v, 1 phase, 60 Hz, 575v, 3 phase, 60 Hz, 3 phase, 60 Hz, or 415/380v, 3 phase, 50 Hz.

Please check the voltage.

NAMEPLATE DATA

Refer to the unit name plate. It indicates all the electrical data for the unit. LOCAL ELECTRICAL CODES OR ANY OTHER APPLICABLE CODES MUST BE COMPLIED WITH PRIOR TO WORKING IN THE UNIT.

Check you unit for the kind of reheat it has. For type C and D piping connections are required. Make sure shut off valves are provided external to the unit.

CONDENSATE DRAINS

An internal condensate drains is provided in the unit and it should carry the water from condensation to the drain.

CONDENSATE PUMP

(Optional): When provided it is mounted on the unit or shipped separately. To avoid any flooding problems provide a separate power source. **WIRE THE PUMP TO SHUT THE SYSTEM OFF IN CASE OF OVERFLOW OR PUMP FAILURE. A SYSTEM CUT OFF TERMINAL IS PROVIDED IN THE UNIT.**

CHILLED WATER UNITS (CKC)

These units are factory piped with a two or three way water regulating valve. These systems are designed for working pressure of 150 psig. Higher pressure- Refer to nameplate.

IMPORTANT SUGGESTION*

In order to have trouble free operation free operation please maintain the humidifiers, regularly check the belts for proper tension and change filters when dirty.

For assistance, please call COMPU-AIRE, INC. at (562)945-8971

ABOUT COMPU-KOOL - AYAN IV SERIES

The COMPU-KOOL – AYAN IV SERIES is designed to provide localized temperature and humidity control in high heat load areas found in commercial and industrial setting. This free standing unit operates independently of the central air conditioning system and provided auxiliary cooling to a pre-selected environment. Completely factory assembled, piped, and wired, the COMPU-KOOL offers flexibility features to meet virtually any floor plan.

Maintaining consistent temperature and humidity conditions requires quick response to changing heat loads in the computer room. COMPU-KOOL meets this challenge through constant fan operation, thus preventing stratification of room air. COMPU-KOOL constantly monitors the return air steam for any change in space conditions; the appropriate air conditioning mode is quickly initiated. All cooling, heating, humidification and dehumidification controls are fully automatic. To keep noise levels at a minimum, thermal and sound barrier insulation fully line cabinet. COMPU-KOOL is available as air, water or glycol cooled system. COMPU-KOOL answers the need for localized environmental control.

TECHNICAL DATA

AYAN IV-IN ROW COOLING SYSTEM

UNIT MODEL: CKC-412-IR NANO

COOLING CAPACITY: At 105°F DB,70.6°F WB- Entering Air Temp.

Total Capacity BTU/HR: 124,700

Sensible Capacity-BTU/HR: 123,300

Leaving Coil 68.3° FBD; 58.7° FWB

COOLING CAPACITY: At 95°F DB,67.9°F WB- Entering Air Temp.

Total Capacity BTU/HR: 99,143

Sensible Capacity-BTU/HR: 94,186

Leaving Coil 67° FBD; 58.2° FWB

CHILLED WATER COIL DATA - Aluminum Fins, 3/8" OD Copper tubing

Face Area-Sq. Ft. 5.35

Rows/FPI 3/12

CHILLED WATER DATA—At 45°F Entering Water Temp.; 55°F Leaving Water Temp.

GPM 24.9

Pressure Drop: Ft of Water (coil) 18.4

BACKWARD INCLINED DIRECT DRIVE PLENUM FANS:

Quantity 6

CFM 3,100

External Static Pressure (Inch of Water) 0"

E.C MOTOR

kW/Fan .145

Qty. 6

ELECTRICAL DATA - @ 460V/3Ph/60Hz

Full Load Amps (FLA) 7.14

Min. Circuit Ampacity (MCA) 8.09

Max. Recomm. Fuse Size (MFS) 15A

PIPING DATA- All Connections are Copper O.D.

Condensate Drains	3/4"
Chilled Water Supply	3/4"
Chilled Water Return	3/4"

PHYSICAL DATA

Length	12.00"
Width	46.38"
Height	78.75"
Unit Weight (Lbs.)	250

INSTALLATION

Prior to placing the unit make sure proper clearances are available:

Front	36"
Rear	36"

UTILITY CONNECTIONS

Electrical connection access for the unit is located on the left front of the top panel and piping connection could be brought from the rear top panel of the unit. Provide isolation shut off valves for all pipes external to the unit.

AIR FLOW

The return air is drawn through the back of the unit and discharged into the room through the front of the unit.

CONNECTIONS

In connecting the unit, five items must be addressed. They are

1. Structural Support
2. Electrical Supply
3. Condensate Drain Connection

STRUCTURAL SUPPORT

The unit can be installed directly on the floor or on the raised floor without the need for any special support. The floor should be level.

ELECTRICAL SUPPORT

A fused disconnect of a HVAC approved circuit breaker must be field provided and installed per the National Electric Code. There is access to the unit for electrical connection through the unit bottom or the lower portion of the unit back. Be sure unit is properly grounded.

A fused disconnect must be provided for the air cooled condenser for air cooled condenser for air cooled units and dry fluid cooler for the glycol cooled units.

CONDENSATE DRAIN CONNECTION

A submersible water pump is placed on the drain pan and will active when the pump detect water condensation and pump the water condensation out from the condensate line located rear top panel of the unit. Field install must connect the condensate line to building drain system properly according to the building guidelines. See Figure 5 - Back view for location of the condensate water pump.

WATER CONNECTIONS

For water cooled units where water supply shall be either city water or cooling tower. Provide a shut off valve in supply and return line for isolation.

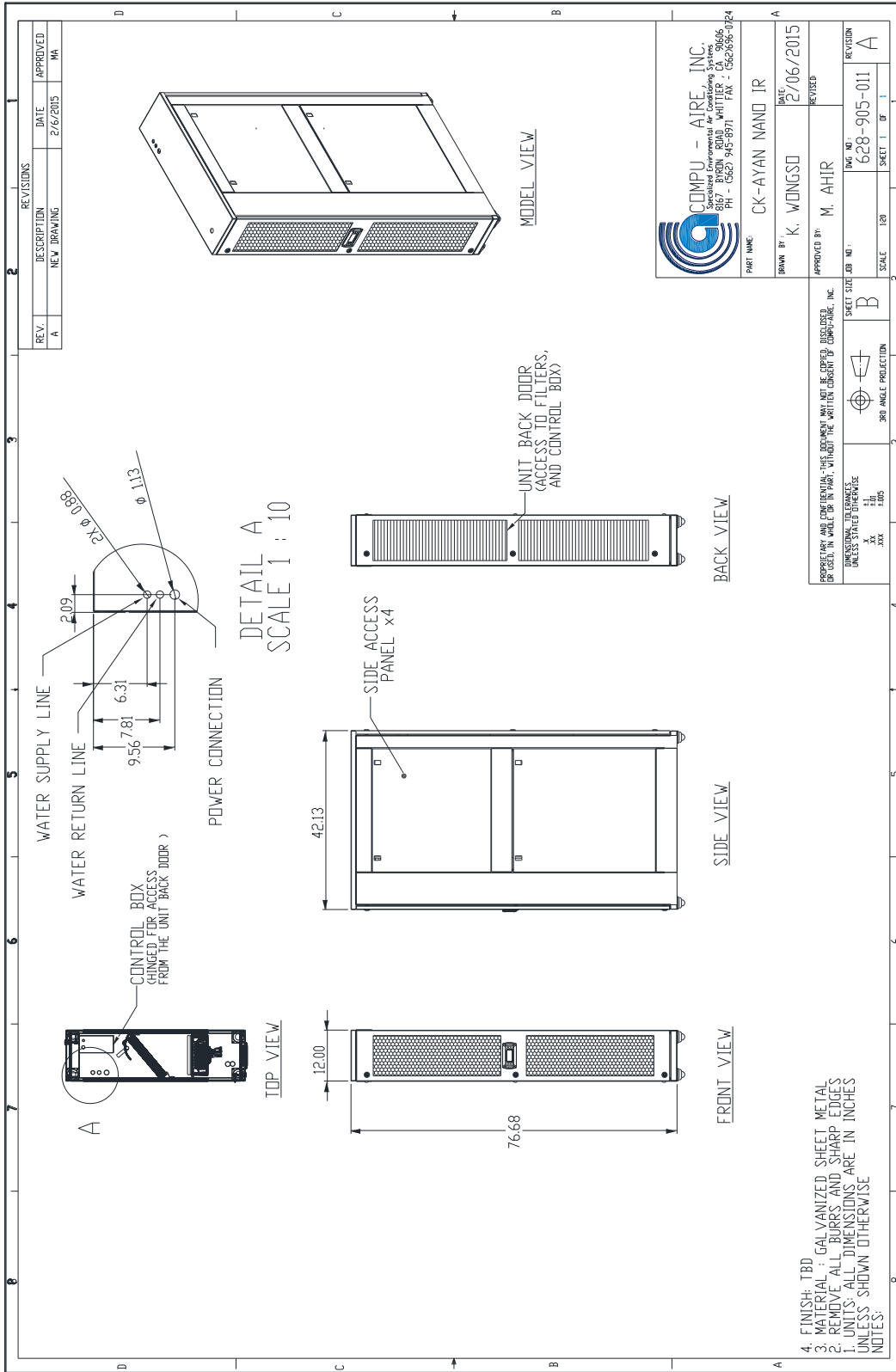

FIGURE 1 - SYSTEM LAYOUT

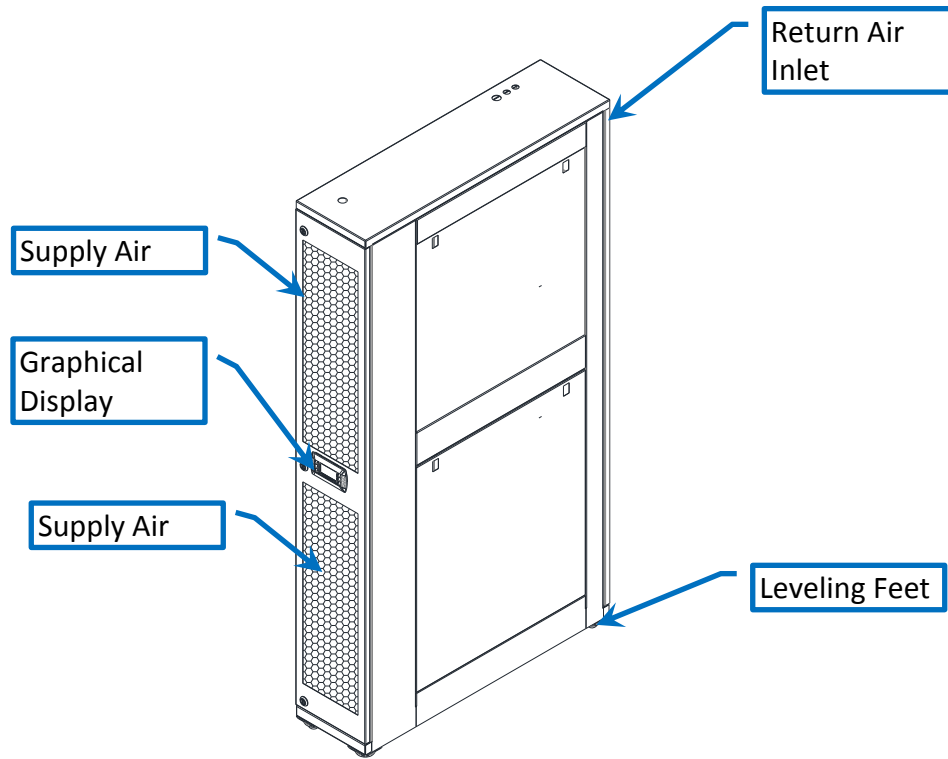

FIGURE 3 - AYAN IV INROW COOLING

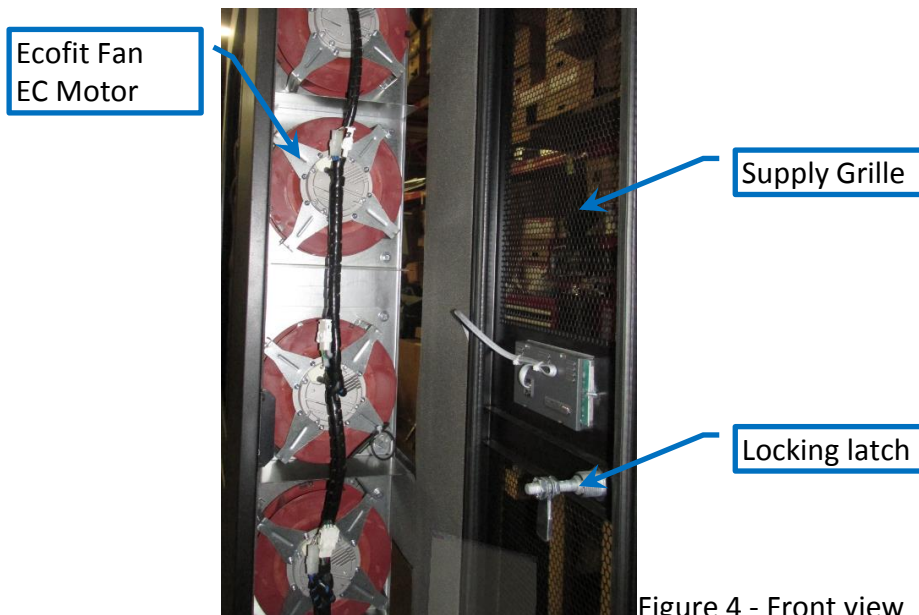

Figure 4 - Front view

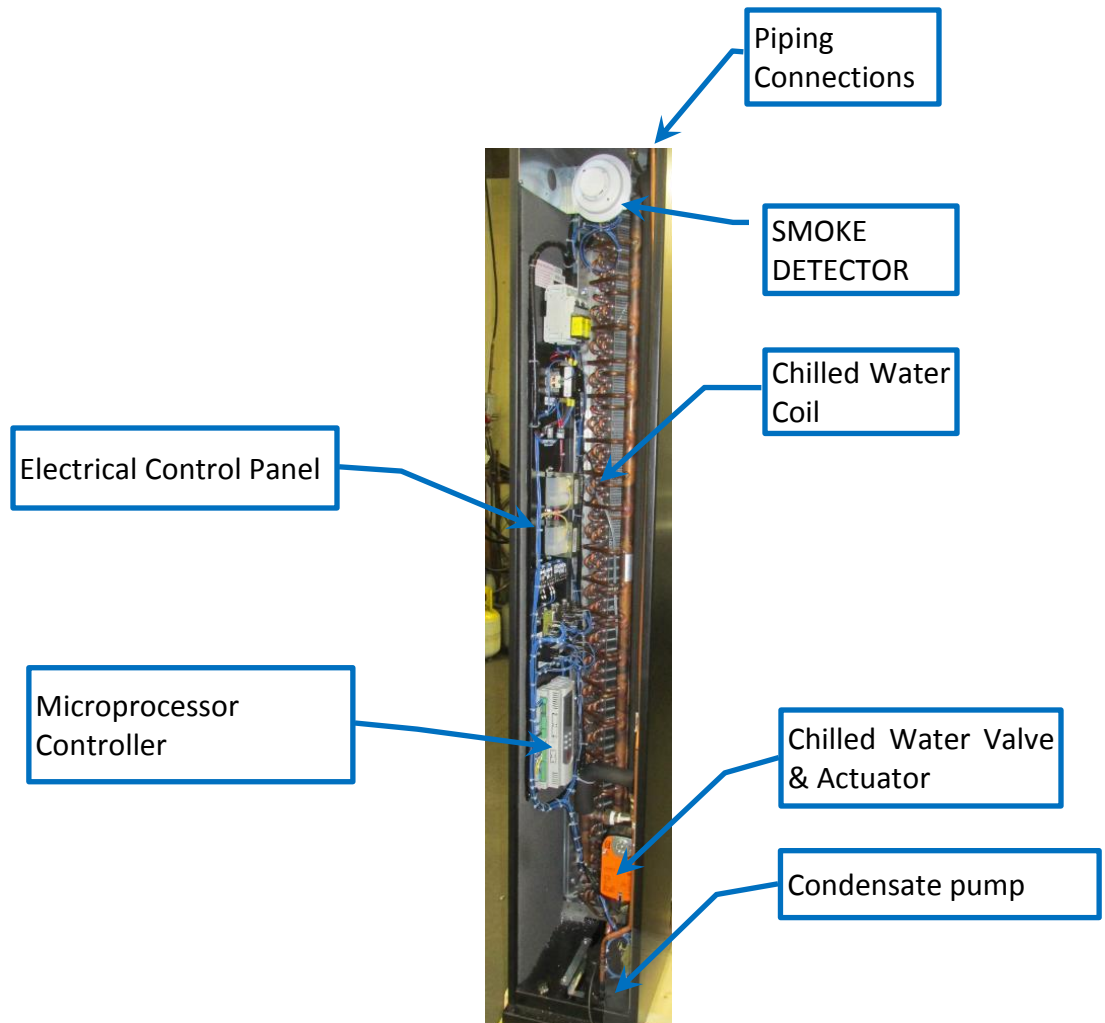

FIGURE 5 - BACK VIEW

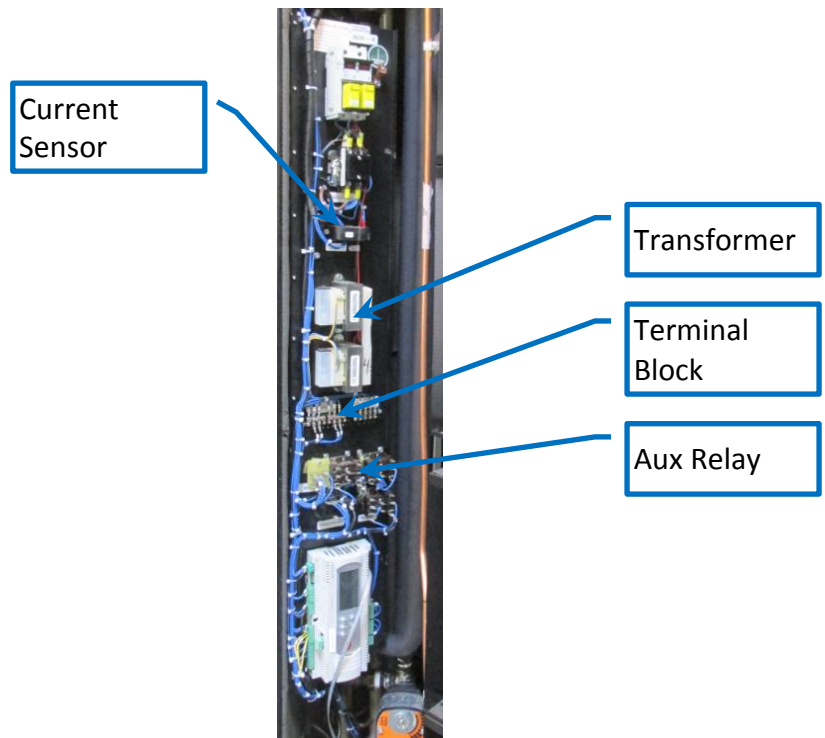

FIGURE 6 - CONTROL PANEL

START-UP AND TEST PROCEDURE

- A. With all power to unit off- Check that ALL WIRING IS CORRECT.

Check that properly sized fuses are installed in the disconnect switch. Correct fuse size and minimum circuit ampacity are listed on the unit nameplate. Now, check the wiring connections in the Main Control Panel to see if they are tight. It is best that this be checked prior to operating the machine. After checking, close the Main Control Panel cover and proceed as follows:

Microprocessor Control Panel – With the system switch in the “OFF” position, apply power to the unit. The “Power ON” light should illuminate.

- B. Check for Correct Phasing

The equipment should now be checked for correct phasing required to make the blower motor turn in the correct directions. For this test it is necessary to open the right side doors of the unit to observe the blower and blower motor. Now, momentarily switch the system switch to the “ON” position and then back to “OFF”. The blower motor will have started and it is therefore possible to determine rotation. On Compu-Aire units, the blower should be rotating in a CLOCKWISE direction. Heaters and humidifiers are not affected by phasing.

GENERAL MAINTENANCE

General maintenance must be performed in regular intervals to provide continued operation of the entire unit. The maintenance intervals must be determined site specifically. Use the maintenance checklist at the end of this manual when performing maintenance. Typically, air filters should be replaced no less than two times per year.

The filters should be checked and changed periodically. When they become dirty, an alarm is activated the filter pressure switch. If the filters are dirty, they must be changed for efficient operation of your system. To check the alarm indicator, cover approximately 75% of the return air opening; the alarm should energize. If the alarm energizes prematurely or does not energize when it should, adjust the filter switch. All doors to machine should remain closed before determining whether an adjustment is necessary. Spare filters should be kept in stock. Filters should be checked monthly and replaced if necessary.

The maintenance intervals must be determined site specifically. Use the maintenance checklist provided if available when performing maintenance. In order to ensure that the system runs trouble free for many years, a follow-up maintenance program (consisting of a minimum of two inspections per year) should be set up. A qualified service mechanic should carry out this semi-annual inspection. The main power supply **must be disconnected and locked off** to avoid accidental startup of the equipment.

- (1) Check electrical components and tighten any loose connections.
- (2) Check all wiring and electrical insulators.
- (3) Check contactors to ensure proper operation and contact point for wear.
- (4) Check that fan motors (if applicable) are operational, ensure fan blades are tight and all mounting bolts are tight.
- (5) Ensure that the condenser surface (if applicable) is cleaned and free of dirt and debris.
- (6) Check the operation of the control system. Make certain that all of the safety controls are operational and functioning properly.
- (7) Check chilled water valve system. Make sure that all mechanical joints and flare nuts are tight.

Service Parts Availability

Genuine replacement service parts should be used whenever possible. Parts may be obtained by contacting your local sales representative or authorized distributor. Contact us 562.945.8971

TROUBLESHOOTING GUIDE

Complaint	Problem	Symptom	Action
1.	Chilled water valve is not opening because of loose or broken wiring.	Display shows chilled water cooling is on or economy cooling is on but, the valve is closed.	Test for 24VAC at valve motor. Check continuity between chilled water pins connection of the microprocessor controller and valve motor. If no voltage, replace microprocessor setting. (refer to supplied controller manual-by other)
2. System does not humidify or does not do so sufficiently.	Control parameters are not set correctly or set as expected.	System seems to function okay otherwise.	Refer to controller setting and check that all control parameters are set correctly.
	Loose or broken wiring in low voltage circuits or bad microprocessor board.	Display shows humidification operating but, the humidifier is not on.	Test for 24VAC at pin connection on controller. If no voltage, check wiring back to system.
3. System is on but, no-thing is operating. The blower is off.	No air flow, fire stat, water on floor or smoke detector alarm is activated.	The display shows one or more of these alarms and the Alarm LED is on.	The system is automatically shut down if any of these conditions occur. Determine what the

			cause is and remedy. Then, press the Reset button on the controller.
4. System does not run.	No 24VAC supply voltage.	Power LED is not on.	Check circuit breaker in system 24VAC circuit and reset if necessary. Check System cutout switch. Test for 24VAC at pins 1 and 2 of controller.

TABLE 1 TROUBLESHOOTING GUIDE

REFERENCE



8167 Byron Rd., Whittier, CA 90606
PH (562) 945-8971 FAX (562) 696-0724

STANDARD ONE YEAR WARRANTY

Job Name: _____ Job No. _____ Date: _____

We warrant this Compu-Aire, Inc. computer room unit to be free from defects in material and workmanship; our obligation being limited to repairing or replacing at our factory any part (except as noted below) within one year from the date of shipment to the original purchaser. Parts to be returned to us PREPAID. Proof of start-up date must be submitted to the factory. This warranty is effective only if the unit has been installed in accordance with our instructions and connected to proper and adequate electric, water and drain services, correctly dehydrated and placed into operation by a competent service representative. Fan motor compressor warranty is covered by original manufacturer's warranty and any repair or replacement should be made by the local authorized service facility as listed the telephone book. Maintenance and service such as replacing filters, humidifier cylinder, infra-red lamps, float valve assemblies, belts, cleaning, lubrication, calibration and adjusting are NOT INCLUDED in this warranty. Replacement or repair parts shall be shipped from the factory pre-paid and invoiced for the full amount. Upon receipt of warranted parts within 30 days with prepayment of the component and which our inspection discloses the parts are defective, and show no signs of misuse, alterations, or abuse, full credit will be issued. Compu-Aire, Inc. does not assume any responsibility for the labor expense for changing defective parts or replacement of any refrigerant or other cooling medium such as glycol etc. All parts and goods are thoroughly inspected and packed to meet the requirements of railroad freight classifications bureaus, and under standard shippers risk, when they leave our factory. SHOULD GOODS ARRIVE DAMAGED, call the agents attention to damage, and have same noted on freight bill. For concealed damage, demand immediate inspection from agent of the shipping company and insist on a notation being made on freight bill.

Purchaser-User	Model Number	Serial Number
		Serial Number
		Serial Number
		Serial Number

FIELD TEST PLANS

THIS FORM MUST BE COMPLETED FOR EACH UNIT AND SENT BACK TO COMPU-AIRE.

TEST DATE START: _____ TEST DATE COMPLETE _____

COMPANY PERFORMING TESTING: _____

ADDRESS: _____

PHONE NUMBER: _____ FAX NO: _____

EMAIL: _____

TECHNICIAN'S NAME: _____

TECHNICIAN PHONE NO: _____

PROJECT NAME: _____

PROJECT ADDRESS: _____

CUSTOMER CONTACT: _____

UNIT MODEL: _____

UNIT SERIAL NO: _____

VOLTAGE: _____

UNIT TYPE:

CHILLED WATER AIR HANDLER

UNIT EQUIPPED WITH:

TYPE OF HUMIDIFIER: _____

HUMIDIFIER SN#: _____ CYLINDER # _____ KW: _____

TYPE OF HEAT: _____ KW: _____

TYPE OF CHILLED WATER VONTROL VALVE: _____

CONDENSATE PUMP SN#: _____

FIELD CHECK

_____ UNIT ALIGNMENT AND SECURELY MOUNTED

_____ DOOR ALIGNMENT

_____ NUTS FOR TIGHTNESS

_____ WIRES FOR CONNECTION TIGHTNESS
 _____ UNIT GROUND CONNECTED
 _____ HIGH AND LOW VOLTAGE WIRING CONDITION FOR ANY DAMAGE
 _____ EC FAN MOTOR ASSEMBLY
 _____ SMOKE DETECTOR
 _____ REMOTE SENSORS
 _____ CONDENSATE PUMP MOUNT
 _____ PIPING AND VALVE SUPPORTS AND AVOID ANY RUBBING PIPES
 _____ INSULATION (CHECK ALL PIPING, C.W. VALVES)
 _____ CONDENSATE DRAIN TRAP
 _____ ISOLATION VALVES INSTALLED
 _____ STRAINER INSTALLED
 _____ SUPPLY AND RETURN AIR CLERANCE AND AIR DISTRIBUTION
 _____ HUMIDIFIER WATER LINES FLUSHED
 _____ HUMIDIFIER CYLINDER IS SECURED
 _____ CHILLED WATER VALVES IS SECURED

SET CONTROLS to test operation:

_____ TEMPERATURE SET POINT
 _____ HUMIDISTAT SETPOINT
 _____ HI LOW TEMPERATURE AND HUMIDITY SET POINTS
 (NOTE ANY CHANGES MADE TO THE CONTROLLER SETTINGS)

UNIT POWER SUPPLY: Test Voltage

LINE VOLTAGE: L1-L2: _____ L2-L3: _____ L1-L3: _____

CONTROL VOLTAGE AT CONTROLLER: _____

evap fan #1

MOTOR HP/KW: _____ F.L.A: _____ VOLTAGE: _____

MODEL # _____

AMP DRAW: L1 _____ L2 _____ L3 _____

CONTROL INPUT SIGNAL MIN/MAX: _____ VDC

evap fan #2

MOTOR HP/KW: _____ F.L.A: _____ VOLTAGE: _____

MODEL # _____

AMP DRAW: L1 _____ L2 _____ L3 _____

CONTROL INPUT SIGNAL MIN/MAX: _____ VDC

evap fan #3

MOTOR HP/KW: _____ F.L.A: _____ VOLTAGE: _____

MODEL # _____

AMP DRAW: L1 _____ L2 _____ L3 _____

CONTROL INPUT SIGNAL MIN/MAX: _____ VDC

evap fan #4

MOTOR HP/KW: _____ F.L.A: _____ VOLTAGE: _____

MODEL # _____

AMP DRAW: L1 _____ L2 _____ L3 _____
CONTROL INPUT SIGNAL MIN/MAX: _____ VDC
evap fan #5
MOTOR HP/KW: _____ F.L.A: _____ VOLTAGE: _____
MODEL # _____
AMP DRAW: L1 _____ L2 _____ L3 _____
CONTROL INPUT SIGNAL MIN/MAX: _____ VDC

evap fan #6
MOTOR HP/KW: _____ F.L.A: _____ VOLTAGE: _____
MODEL # _____
AMP DRAW: L1 _____ L2 _____ L3 _____
CONTROL INPUT SIGNAL MIN/MAX: _____ VDC

REHEAT
TYPE: ELECTRIC: _____ NO. OF STAGES: _____
HEATER AMP DRAW:
STAGE 1: L1: _____ L2: _____ L3: _____
STAGE 2: L1: _____ L2: _____ L3: _____

Humidifier
AMP DRAW: L1: _____ L2: _____ L3: _____
VERIFY FILL VALVE OPERATION: _____
DRAIN VALVE OPERATION: _____
CONDITION in 100% cooling TEST mode
SUPPLY AIR TEMPERATURE: _____ °F RETURN AIR TEMPERATURE: _____
RETURN
RETURN AIR HUMIDITY: _____ %
C.W. SUPPLY TEMPERATURE: _____ °F C.W. RETURN TEMPERATURE: _____
°F

CHILLED WATER
WATER IN TEMP: _____ °F WATER OUT TEMP: _____ °F
CHILLED WATER VALVE PRT NUMBER:

CHILLED WATER VALVE OPERATION: _____ MIN/MAX: _____ VDC RANGE

Automatic Controls
CONTROLLER MODEL: _____
SOFTWARE REVISION: _____ REVISION DATE: _____

CHECK ALL ALARMS

CALIBRATE SENSORS AS NEEDED

VERIFY POINTS LIST WITH CONTROLS CONTRACTOR

VERIFY OPERATION OF LONWORKS COMMUNICATION CARD WITH BMS

CHECK ALL ANALOG OUT PUTS

_____ CHECK ALL DIGITAL OUT PUTS

Alarm set points

TEMPERATURE: HIGH: _____ LOW: _____

HUMIDITY: HIGH: _____ LOW: _____

(NOTE ANY CHANGES MADE TO THE CONTROLLER SETTINGS)

Condensate Pump

WET TEST: _____

TECHNICIAN COMMENTS

NOTE ALL READINGS AND ANY ADJUSTMENT MADE AT THE JOB SITE:

ANY VISUAL DAMAGE:

Technical Support/ Service

Website

www.compu-aire.com

Location

Compu-Aire, Inc.
8167 Byron Road
Whittier, California 90606
United States of America
+1 (562) 945-8971 (Phone)
+1 (562) 696-0724 (Fax)

While every precaution has been taken to ensure the accuracy and completeness of this literature, Compu-Aire assumes no responsibility and disclaims all liability for damages resulting from use of this information or for any errors or omissions.

© 2014 Compu-Aire, Inc

All rights reserved throughout the world. Specifications subject to change without notice.

