



# SUPERLOK USA

## Instrument High Technology Valve, Flange & Fitting Series

# Manifold & Gauge Valves



## SUPERLOK®

# SUPERLOK USA

[www.SuperlokUSA.com](http://www.SuperlokUSA.com)

5777 Olivas Park Dr Unit#G  
Ventura, CA 93003

805-658-2043

[sales@superlokusa.com](mailto:sales@superlokusa.com)

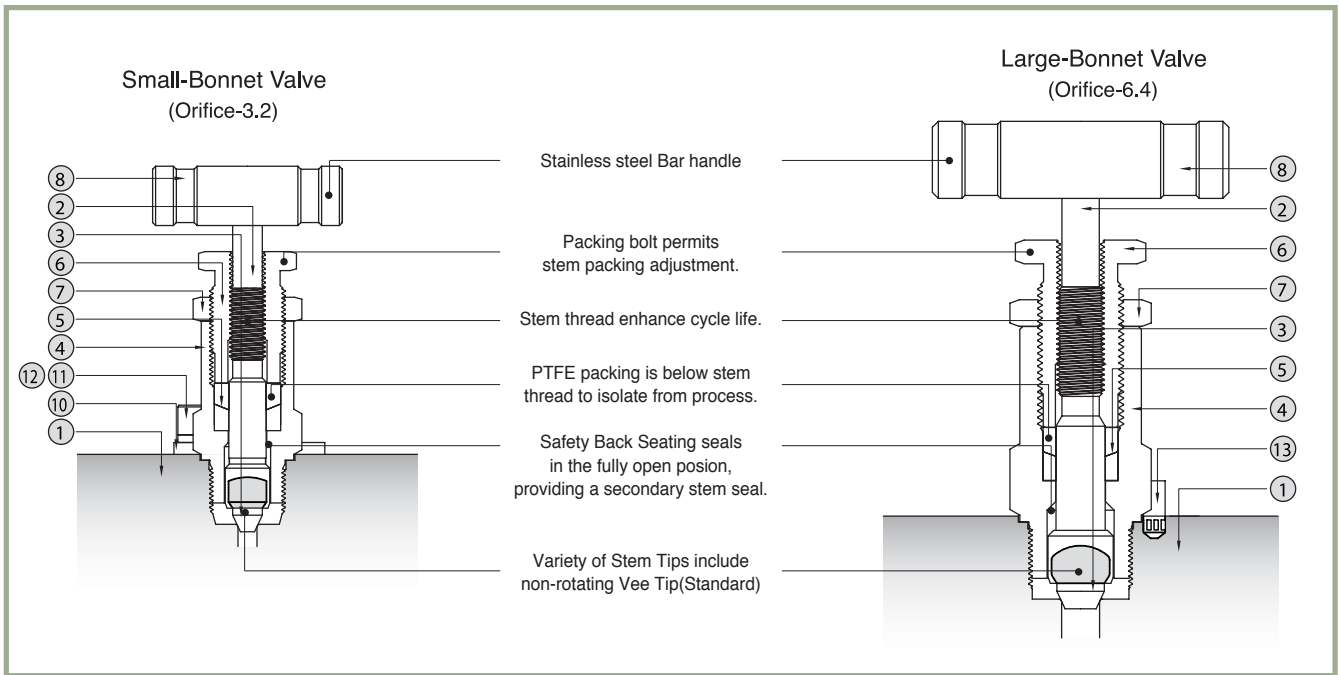

**Technical Data**

**Material of Construction**

Component	Material Grade
1 Body	SS316 / A276 or A479
2 Stem	SS316 / A276 or A479
3 Vee Tip	SS316 / A479
4 Bonnet	SS316 / A276 / or A479
5 Packing	PTFE Grafoil (optional)
6 Packing Bolt	SS316 / A276 / or A479
7 Lock Nut	SS316 / A276 / or A479
8 Handle	Stainless Steel
9 Set Screw	Stainless Steel
10 Locking Plate	Stainless Steel
11 Wrench Bolt	Stainless Steel
12 Spring Washer	Stainless Steel
13 Stop Pin	Stainless Steel

**Orifice**

3.2mm (0.125 in.)	2-Valve Manifolds Block, Bleed Valve 5-Valve Manifolds Equalizer, Bleed Valve
6.4mm (0.250 in.)	3-Valve Manifolds Block, Equalizer Valve 5-Valve Manifolds Block Valve

**Features**

- 2-,3-,and 5-valves Instrument manifolds valves.
- Pressure Rating up to 6000psig (413bar) @ 100 °F(37°C)
- Temperature up to 1200 °F(648°C) with optional Grafoil packing
- All 316 stainless steel construction with PTFE packing.

**Testing**

Each valve on every manifold is factory tested with nitrogen gas. The test is performed to a maximum allowable leak rate of 0.1scc/min.

**Pressure-Temperature Rating**

Body Material	SS 316	
	Packing Material	
	PTFE	Grafoil
Temperature(°C)	Working Pressure psig(bar)	
-65 (-53) to 100(37)	6000 (413)	6000 (413)
200 (93)	5160 (355)	5160 (355)
250 (121)	4910 (338)	4910 (338)
300 (148)	4660 (321)	4660 (321)
350 (176)	4470 (307)	4470 (307)
400 (204)	4280 (294)	4280 (294)
450 (232)	4130 (284)	4130 (284)
500 (260)	-	3980 (274)
550 (287)	-	3870 (266)
600 (315)	-	3760 (259)
650 (343)	-	3700 (254)
700 (371)	-	3600 (248)
750 (398)	-	3520 (242)
800 (426)	-	3460 (235)
850 (454)	-	3380 (232)
900 (482)	-	3280 (225)
950 (510)	-	3220 (221)
1000 (537)	-	3030 (208)
1050 (565)	-	3000 (206)
1100 (593)	-	2685 (184)
1150 (621)	-	2285 (157)
1200 (648)	-	1715 (118)

\* Note  
450 °F(232 °C) with standard PTFE packing.  
1200 °F(648 °C) with Optional Grafoil packing.

## 2-Valve Manifolds

### Horizontal Style (Remote Mounting)

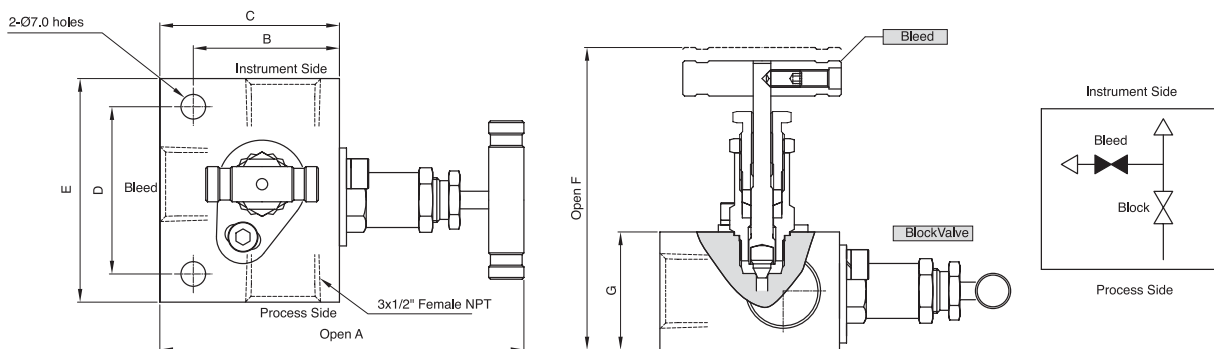

Ordering No.	End Connections			Weight Dimensions (mm)						
	Process	Instrument	Bleed	A	B	C	D	E	F	G
SM2V-F-8N	1/2" Female NPT			103.5	41.5	51	47.5	63.5	85.9	33.5

### Horizontal Single Flange Style (Direct Mounting)

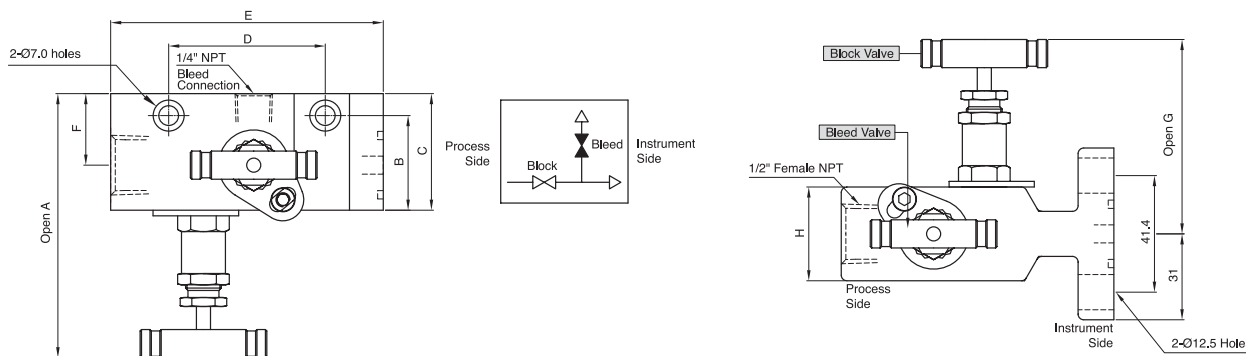

Ordering No.	End Connections			Weight Dimensions (mm)							
	Process	Instrument	Bleed	A	B	C	D	E	F	G	H
SM2VF-F-8N	1/2" Female NPT	Flange	1/4" Female NPT	93.8	33.6	41.4	47.8	97.0	25.4	69.0	31.8

### Vertical Style (Direct Mounting)

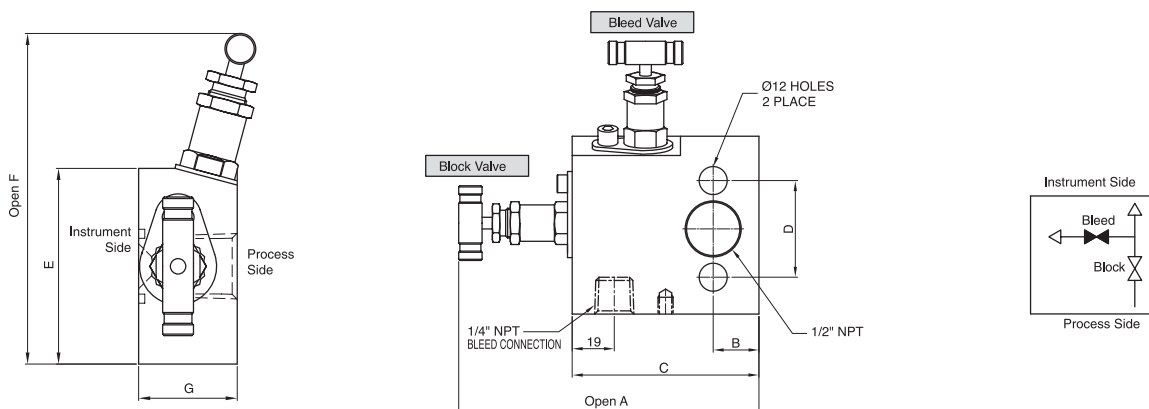

Ordering No.	End Connections			Weight Dimensions (mm)						
	Process	Instrument	Bleed	A	B	C	D	E	F	G
SM2VD-F-8N	1/2" Female NPT	Flange	1/4" Female NPT	116.0	17.0	63.5	41.4	63.5	115.0	28.6

\* Dimension are for reference only and are subject to change. \* To order a manifold with optional Grafoil packing, add-G to the manifold ordering number.

## 3-Valve Manifolds

### Horizontal Style (Remote Mounting)

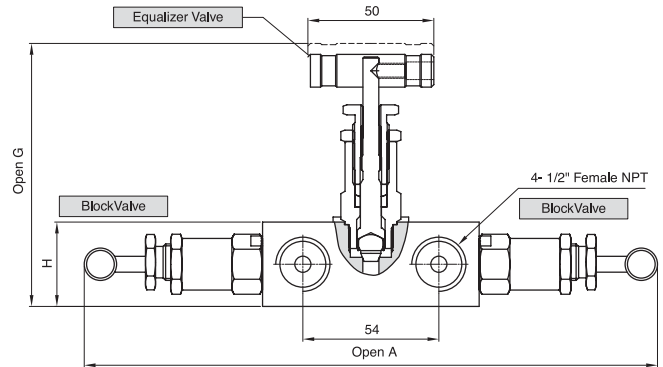
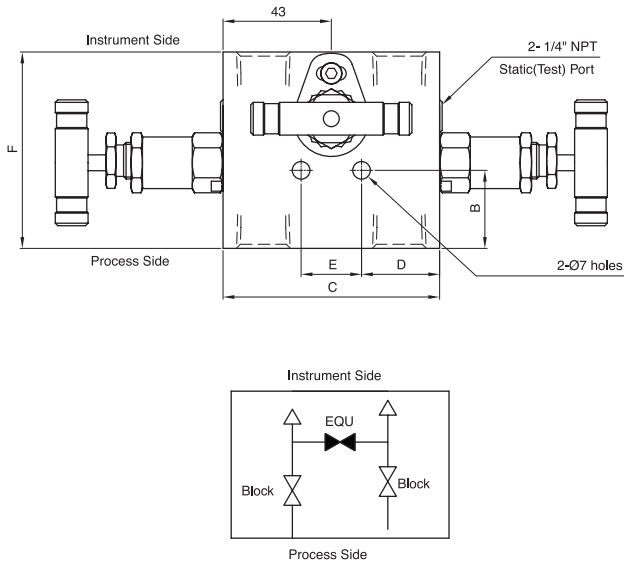

Ordering No.	End Connections		Weight Dimensions (mm)							
	Process	Instrument	A	B	C	D	E	F	G	H
SM3V-F-8N	1/2" Female NPT		228.0	31.0	86.0	31.0	24.0	78.0	106.0	33.5

\* Dimension are for reference only and are subject to change.  
 \* To order a manifold with optional Grafoil packing, add-G to the manifold ordering number.

### Horizontal Single Flange Style (Direct Mounting)

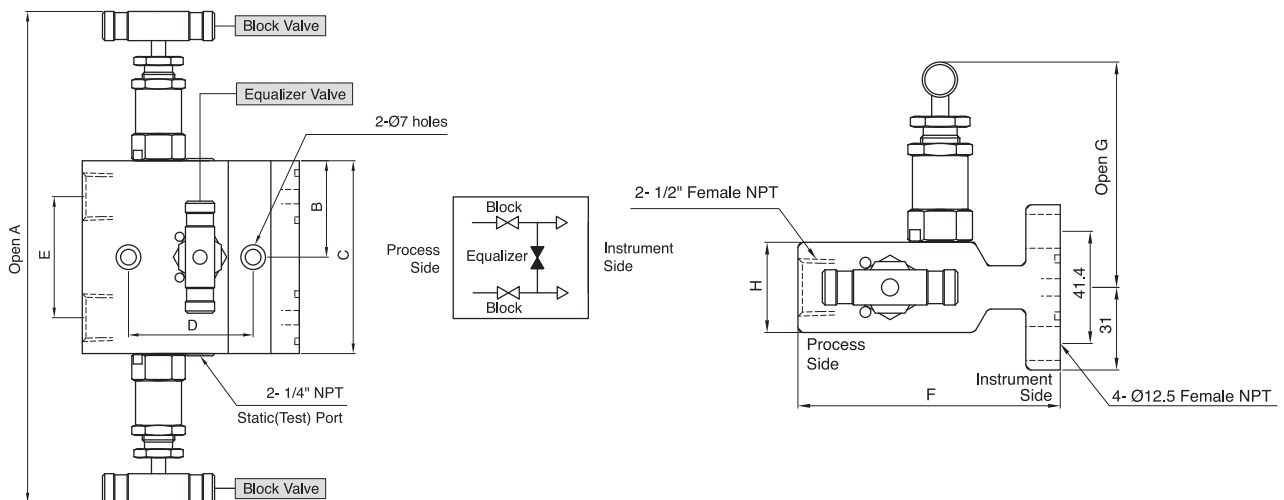

Ordering No.	End Connections		Weight Dimensions (mm)							
	Process	Instrument	A	B	C	D	E	F	G	H
SM3VF-F-8N	1/2" Female NPT	Flange	228.0	43.0	86.0	55.6	54.0	97.0	87.7	31.8

\* Dimension are for reference only and are subject to change.  
 \* To order a manifold with optional Grafoil packing, add-G to the manifold ordering number.

## 3-Valve Manifolds

### Horizontal Dual Flange Style (Direct Mounting)

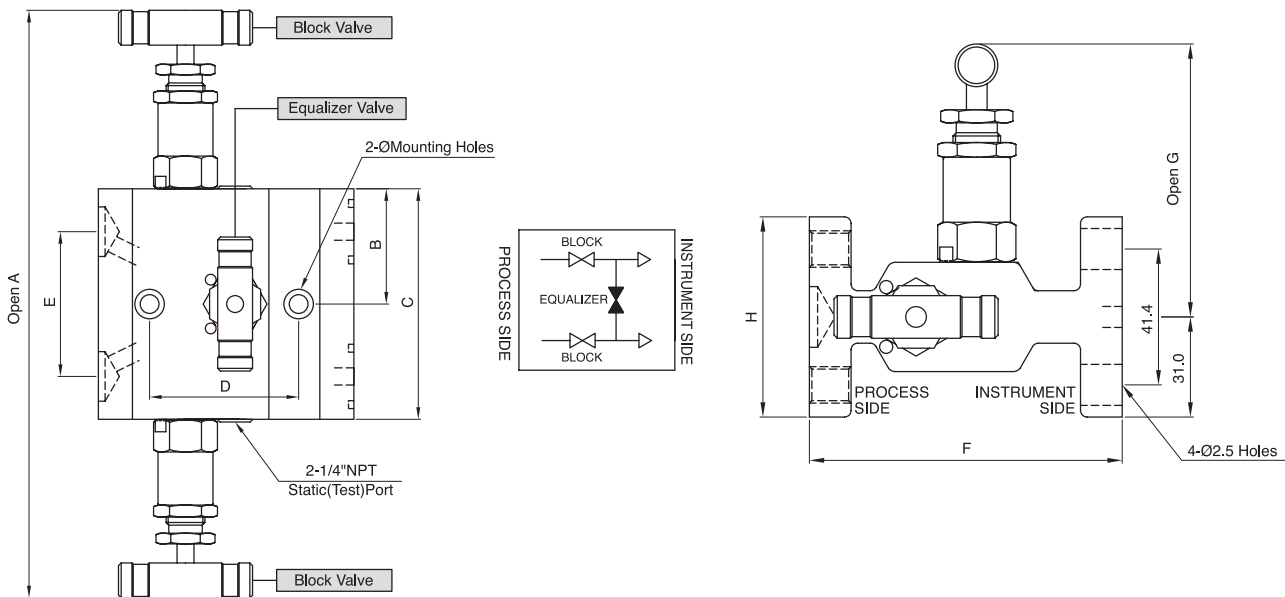

Ordering No.	End Connections		Weight Dimensions (mm)							
	Process	Instrument	A	B	C	D	E	F	G	H
SM3VDF	Flange	Flange	228.0	43.0	86.0	55.6	54.0	96.4	87.7	62.0

\* Dimension are for reference only and are subject to change.  
 \* To order a manifold with optional Grafoil packing, add-G to the manifold ordering number.

### Vertical Style (Direct Mounting)

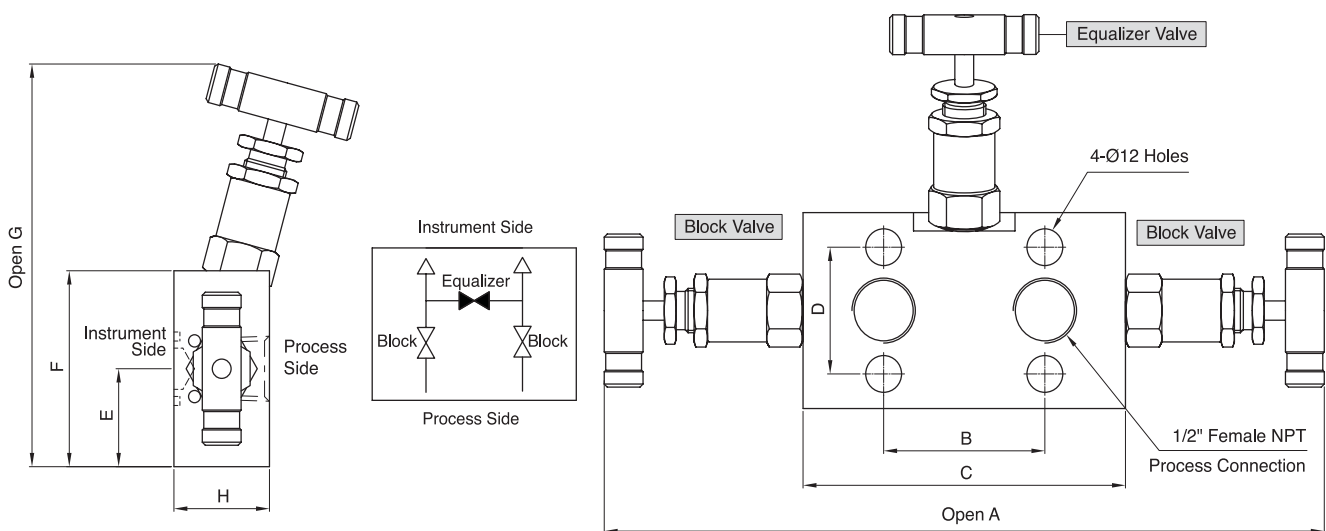

Ordering No.	End Connections		Weight Dimensions (mm)							
	Process	Instrument	A	B	C	D	E	F	G	H
SM3VD-F-8N	1/2" Female NPT	Flange	250.0	54.0	108.0	41.4	32.0	64.0	136.0	32.0

\* Dimension are for reference only and are subject to change.  
 \* To order a manifold with optional Grafoil packing, add-G to the manifold ordering number.

## 5-Valve Manifolds

### Horizontal Style (Remote Mounting)

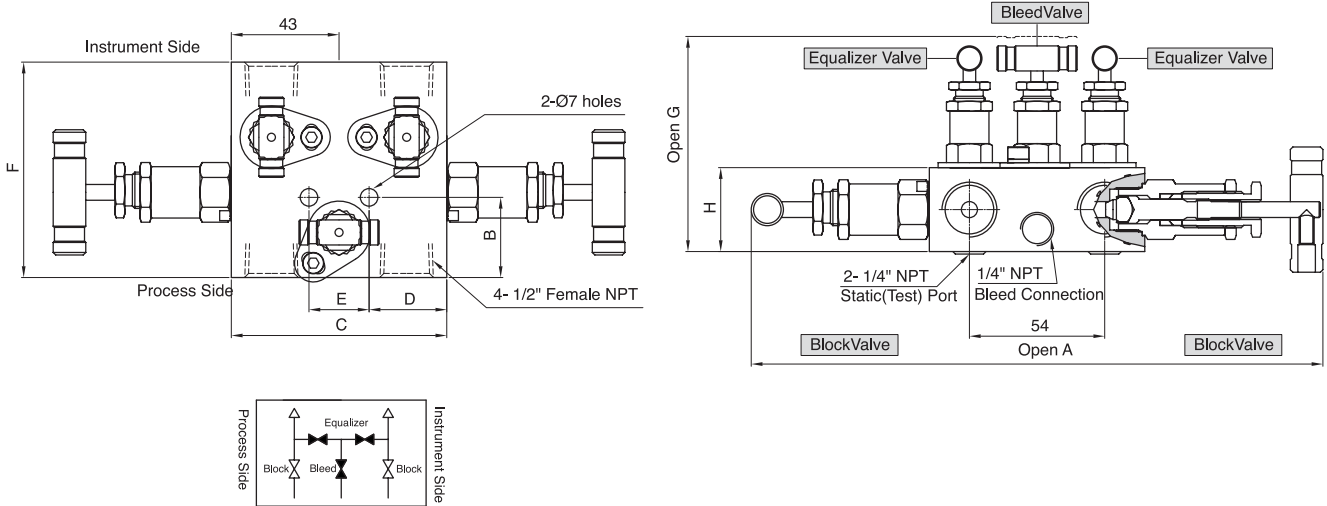

Ordering No.	End Connections			Weight Dimensions (mm)							
	Process	Instrument	Bleed	A	B	C	D	E	F	G	H
SM5V-F-8N	1/2" Female NPT		1/4" Female NPT	228.0	32.0	86.0	31.0	24.0	86.0	85.9	33.5

\* Dimension are for reference only and are subject to change.

\* To order a manifold with optional Grafoil packing, add-G to the manifold ordering number.

### Horizontal Single Flange Style (Direct Mounting)

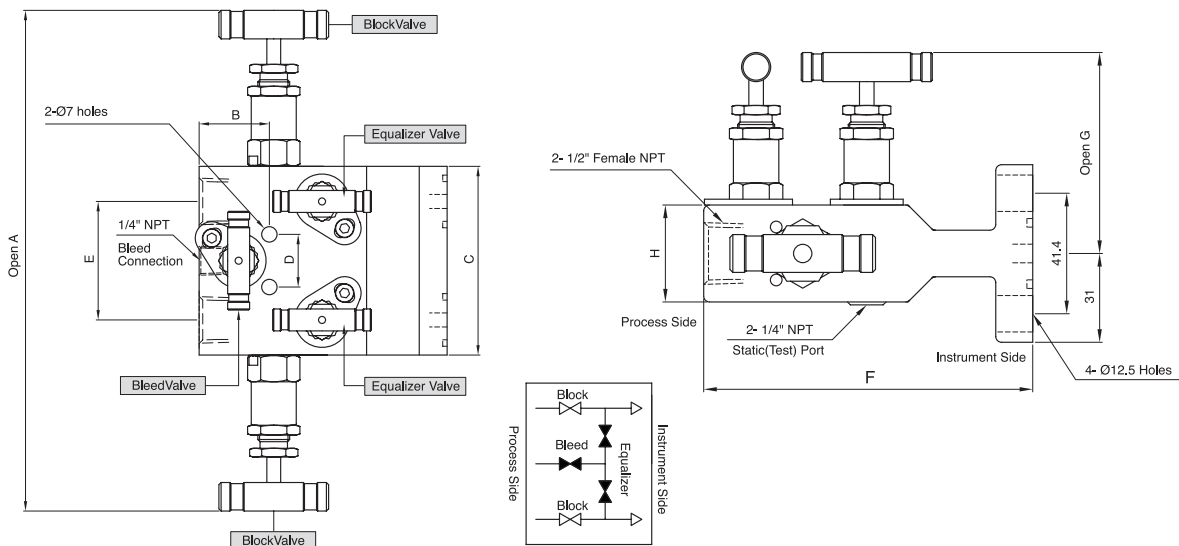

Ordering No.	End Connections			Weight Dimensions (mm)							
	Process	Instrument	Bleed	A	B	C	D	E	F	G	H
SM5VF-F-8N	1/2" Female NPT	Flange	1/4" Female NPT	228.0	40.0	86.0	24.0	54.0	102.0	69.0	31.8

\* Dimension are for reference only and are subject to change.

\* To order a manifold with optional Grafoil packing, add-G to the manifold ordering number.

## 5-Valve Manifolds

### Horizontal Dual Flange Style (Direct Mounting)

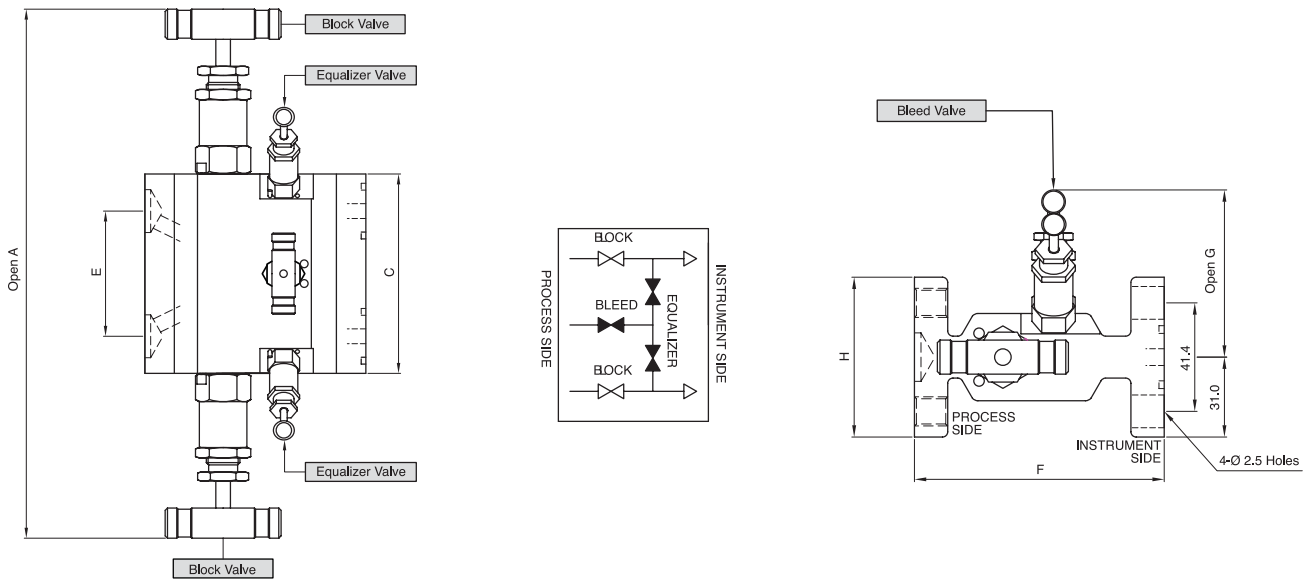

Ordering No.	End Connections			Weight Dimensions (mm)							
	Process	Instrument	Bleed	A	B	C	D	E	F	G	H
SM5VDF	Flange	Flange	1/4" Female NPT	228.0	32.0	86.0	24.0	54.0	96.4	69.0	61.0

\* Dimension are for reference only and are subject to change.  
 \* To order a manifold with optional Grafoil packing, add-G to the manifold ordering number.

### Vertical Style (Direct Mounting)

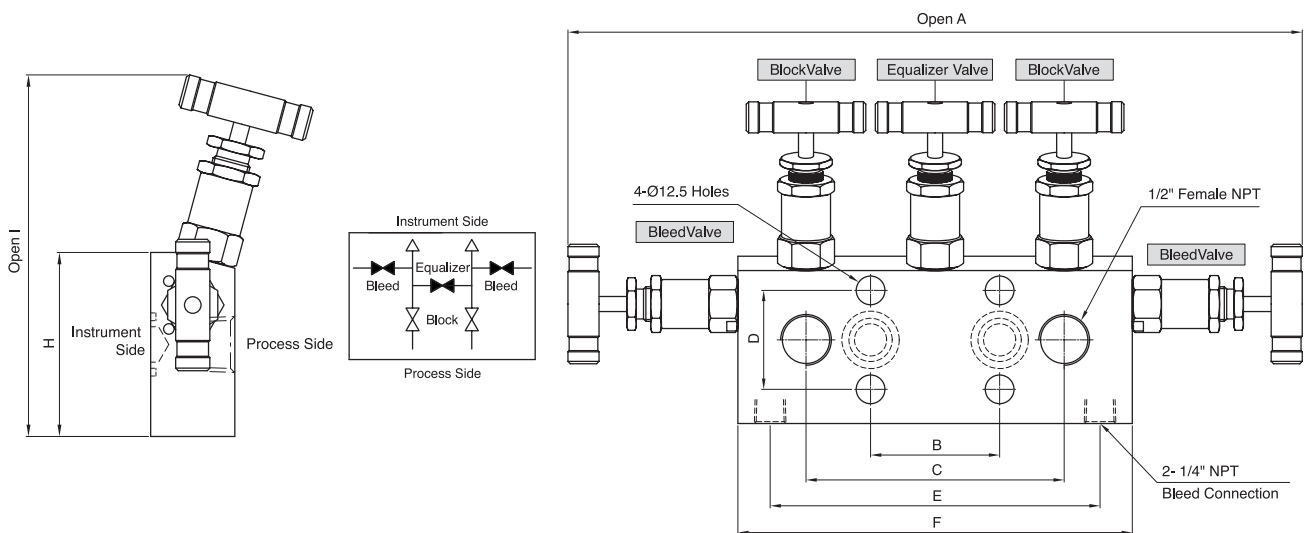

Ordering No.	End Connections			Weight Dimensions (mm)								
	Process	Instrument	Bleed	A	B	C	D	E	F	G	H	I
SM5VD-F-8N	1/2" Female NPT	Flange	1/4" Female NPT	312.0	54.0	102.0	41.4	138.0	158.0	148.0	76.2	32.0

\* Dimension are for reference only and are subject to change.  
 \* To order a manifold with optional Grafoil packing, add-G to the manifold ordering number.

## Manifolds Accessories

### Flange Bolts & Seals

#### Flange Bolts

Flange Bolt	Ordering No.	Hex Size mm (in.)	Length mm (in.)	Threads	Bolt Material Designator
Standard Hex Head Bolt	SM-FB	15.87 (5/8)	25.0 (1.0)	7/16 - 20	Stainless Steel : -S Carbon Steel : -C
Long Stud with Hex Nut	SM-LFB		58.0 (2.28)		
Short Hex Head Bolt	SM-SFB		22.2 (0.875)		



#### Flange Seals

Seal Material	Ordering No.	Temperature Rating
Viton	SM - FS - V	-20 °F ~ 450 °F (-28 °C ~ 232 °C)
PTFE	SM - FS	-65 °F ~ 250 °F (-53 °C ~ 121 °C)
Grafoil	SM - FS - GR	-65 °F ~ 1000 °F (-53 °C ~ 537 °C)

### Concentric & Eccentric Oval Flange

- Eccentric Flanges and Pipe Nipple allow connections of flange - to - flange manifolds to process flange taps or process root valves.
- Standard connection is female NPT 1/2".
- Concentric & eccentric oval flange ordering number : Concentric oval flange female NPT 1/2" : SM - COF - F8N  
Eccentric oval flange female NPT 1/2" : SM - EOF - F8N
- Dimensions, in millimeters (inches), are for reference only and are subject to change.

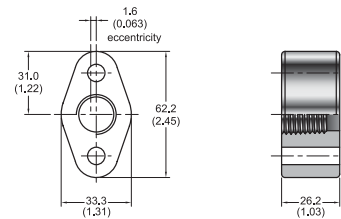

### Concentric & Eccentric Pipe Nipple

Type	Ordering No.	Material	Pressure Rating @70 °F (20 °C) psig (bar)	Temperature Rating °F (°C)	Pressure Rating @Max. temperature
Concentric	SM - CPN - S	SS316 / A276	10000 (689)	-65 to 1200 (-53 to 648)	2850 psig @ 1200 °F (196 bar @ 648 °C)
	SM - CPN - C	Carbon Steel / A108	8000 (551)	-20 to 350 (-28 to 176)	6970 psig @ 350 °F (480 bar @ 176 °C)
Eccentric	SM - EPN - S	SS316 / A276	7500 (516)	-65 to 1200 (-53 to 648)	2140 psig @ 1200 °F (147 bar @ 648 °C)
	SM - EPN - C	Carbon Steel / A108	6000 (413)	-20 to 350 (-28 to 176)	5230 psig @ 350 °F (360 bar @ 176 °C)

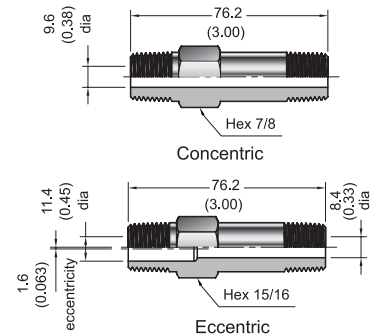

\* Dimensions, in millimeters (inches), are for reference only and are subject to change.

### Calibration Fittings



Calibration fittings connect directly to the bleed port of differential pressure transmitter.

Material	Ordering No.	SUPERLOK O.D	Stright Male Thread
Stainless Steel / A276	SCAL4 - 1U	1/4"	1/4 - 28UNF
	SCAL4 - 2U		5/16 - 24UNF

### Vent plugs, Bleed & Purge Valves

- Bleed & Purge valves used to vent to atmosphere and to assist in calibration.
- Are offered in 1/4, 3/8, and 1/2 in. male NPT sizes.
- For more information, see the SUPERLOK BLEED & PURGE VALVE catalog. (BMT CBPV)
- Dimensions, in millimeters (inches), are for reference only and are subject to change.





# Gauge Valve

## Features

- Stainless Steel construction.
- 1/2 in. and 3/4 in. male to 1/2 in. female end connections.
- 1/2 in. female gauge ports standard.

## Gauge / Root Valve

### SGBV(Gauge Valve)

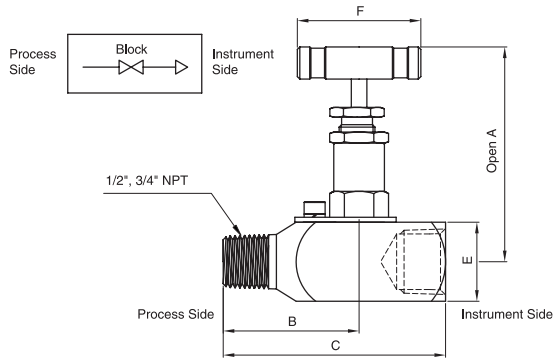

### SGRV(Gauge Root Valve)

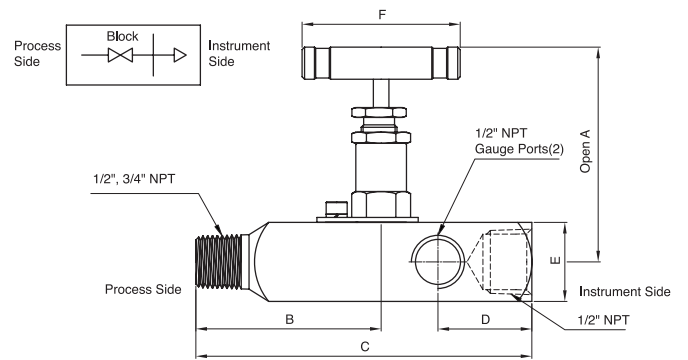

Ordering No.	End Connections		Dimensions (mm)					
	Process	Instrument	A	B	C	D	E	F
SGBV-MF-8N	1/2" Male NPT	1/2" Female NPT	87.0	54.0	90.0	-	32.0	45.0
SGBV-MF-12N8N	3/4" Male NPT	1/2" Female NPT						
SGRV-MF-8N	1/2" Male NPT	1/2" Female NPT	87.0	75.0	136.0	38.1	32.0	45.0
SGRV-MF-12N8N	3/4" Male NPT	1/2" Female NPT						

\* Dimension are for reference only and are subject to change.  
 \* To order a manifold with optional Grafoil packing, add-G to the manifold ordering number.

## Gauge 2-Valve

### SGBV 2

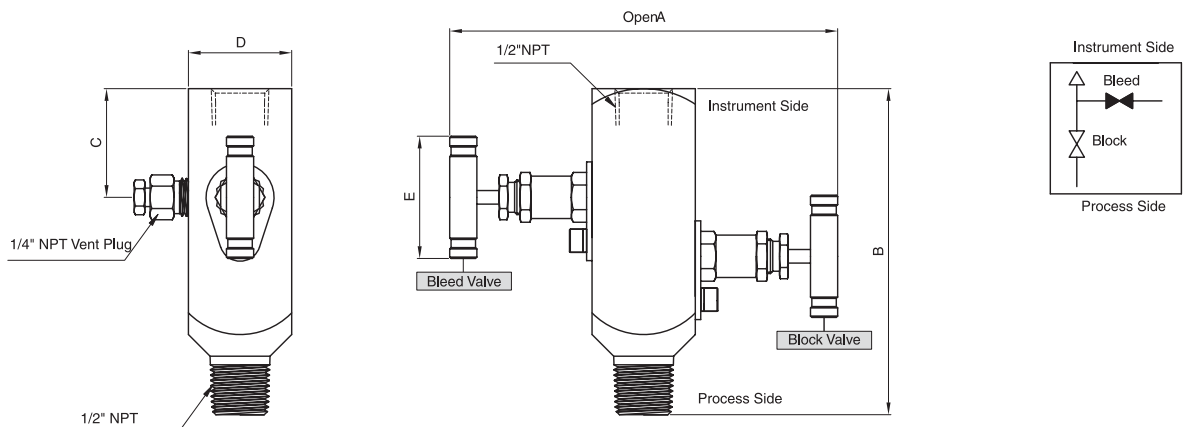

Ordering No.	End Connections		Dimensions (mm)				
	Process	Instrument	A	B	C	D	E
SGBV2-MF-8N	1/2" Male NPT	1/2" Female NPT	142	120	40	38	45

\* Dimension are for reference only and are subject to change.  
 \* To order a manifold with optional Grafoil packing, add-G to the manifold ordering number.