

PROPRIETARY AND CONFIDENTIAL
 THE INFORMATION CONTAINED IN THIS DRAWING IS THE SOLE PROPERTY OF VECTOR ELECTRONICS & TECHNOLOGY, INC. ANY REPRODUCTION IN PART OR AS A WHOLE WITHOUT THE WRITTEN PERMISSION OF VECTOR ELECTRONICS & TECHNOLOGY, INC. IS PROHIBITED.

REVISIONS				
ZONE	REV	DESCRIPTION	DATE	APPROVED
ALL	A	INITIAL RELEASE	02/23/15	
SHEET 2	B	SHEET 2, DIM "A" FOR 3U X 4HP AND 6U OR 9U X 4HP WAS NOTED AS DIM "H"	04/01/15	
SHEET 3	C	ADDED 3U RTM FRONT PANELS ON SHEET 3	02/01/17	
ALL	D	ADDED "SS" METAL PRESS-FIT SLEEVE OPTION	02/05/20	
SHEET 2, 3	E	ADDED OPTIONAL UPPER L-BRACKET (P/N: 3250-0017-01) LOCATION DIM TO 3U PANELS	07/20/20	
SHEET 2	F	CHANGED EMC GASKET MATERIAL TO STAINLESS STEEL WAS BR6Cu WITH BRIGHT NICKEL	12/09/20	

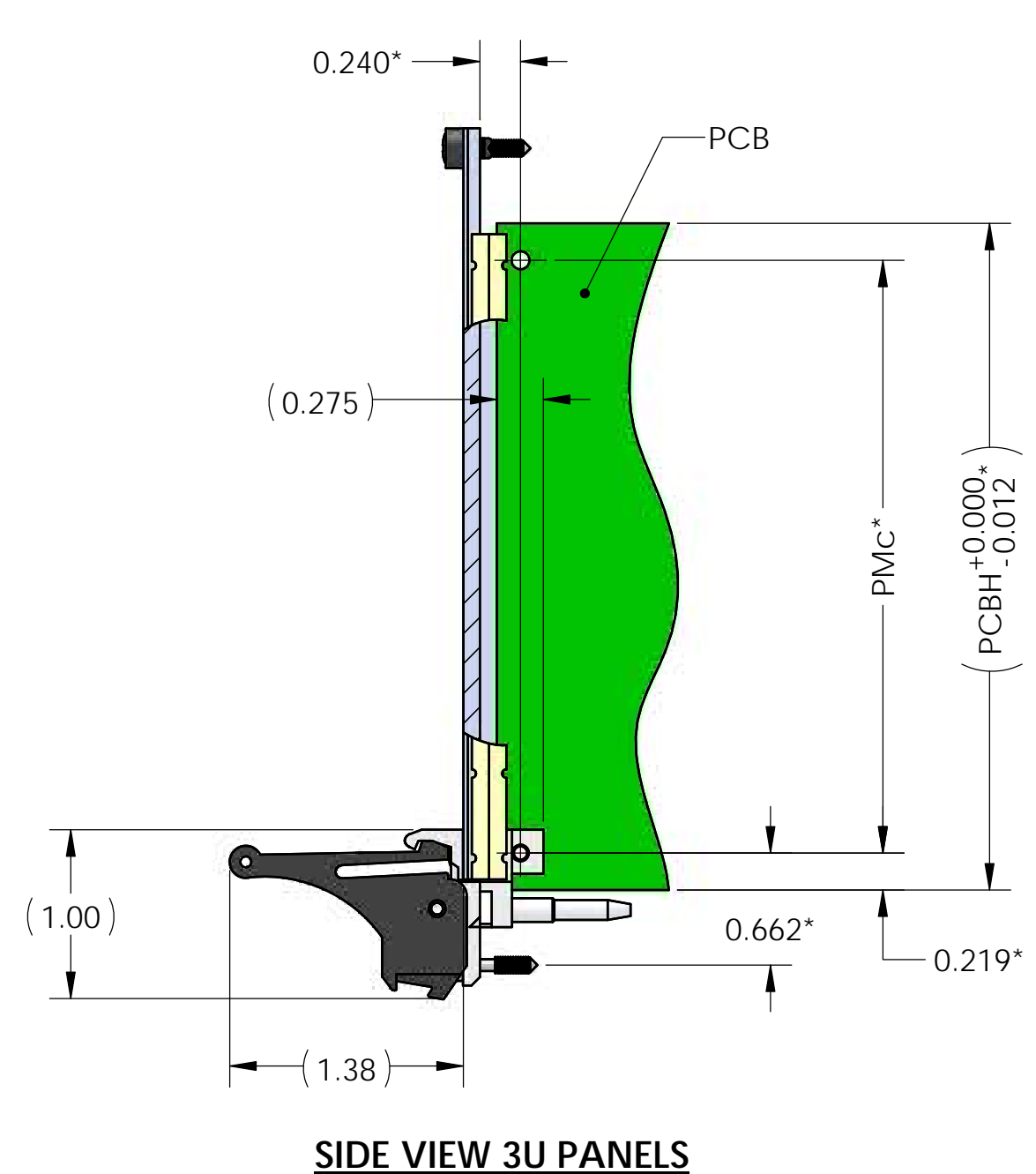
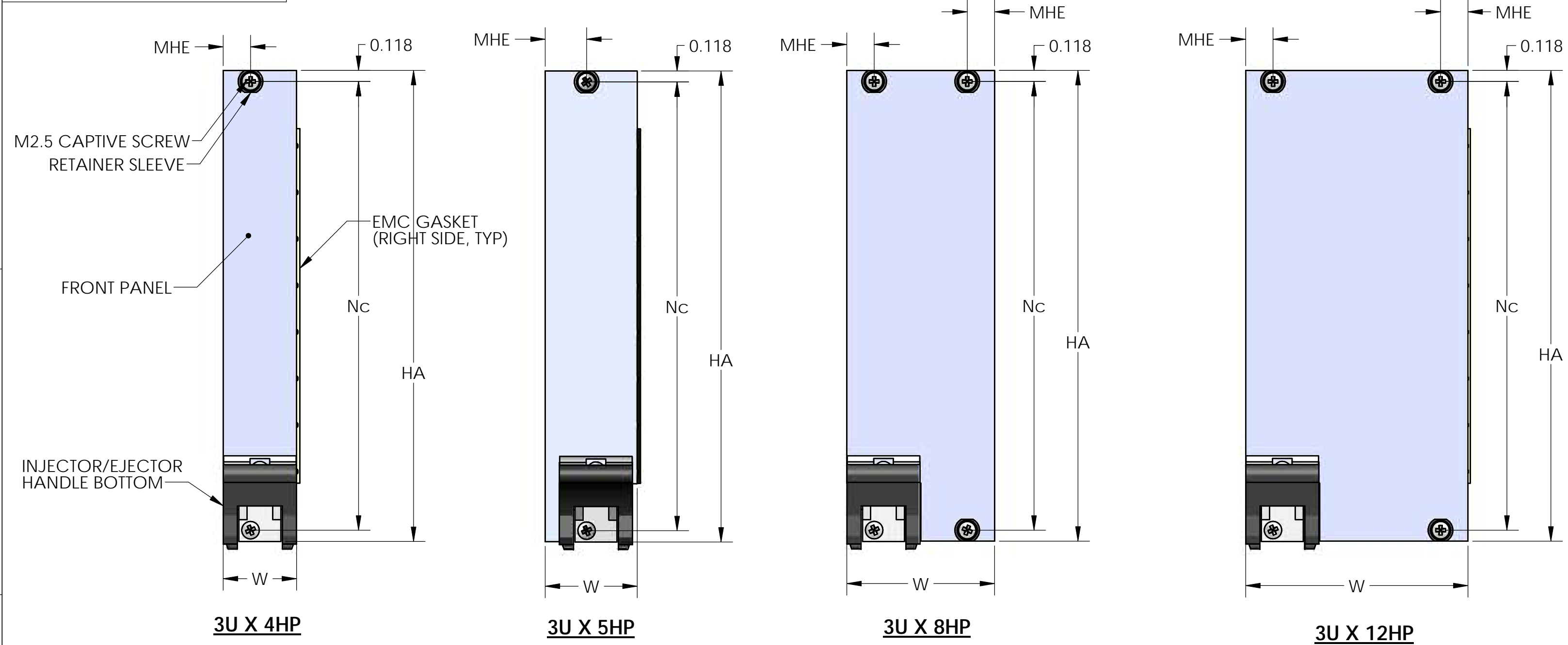

- NOTES:
 1. FRONT PANELS ARE SHOWN WITH TYPE IV INJECTOR/EJECTOR HANDLES
 2. TOP/BOTTOM INJECTOR/EJECTOR HANDLES AND PCB SHOWN FOR REFERENCE ONLY. NOT PART OF FRONT PANEL KIT
 3. * INDICATES DIMENSIONS PER IEEE 1101.10
 4. HEIGHT DIM "H" INCLUDES TYPE IV HANDLE'S KEYING BRACKET
 5. SHOWN AS FRONT PLUG-IN CARD. ROTATE 180° FOR RTM (REAR TRANSITION MODULE)

DIMENSIONS TABULATION

PART NO	DESCRIPTION	HA	WA	Nc	MHE	PMc	PCBH
FP52B4HP-1	3U X 4HP	5.059	0.788	4.823	0.294	3.500	3.937
FP52B5HP-1	3U X 5HP		0.988		0.445		
FP52B8HP-1	3U X 8HP		1.588		0.294		
FP52B12HP-1	3U X 12HP		2.388		0.294		
FP52B4HP-4	3U X 4HP	5.059	0.788	4.823	0.294	3.500	3.937
FP52B5HP-4	3U X 5HP		0.988		0.445		
FP52B8HP-4	3U X 8HP		1.588		0.294		
FP52B12HP-4	3U X 12HP		2.388		0.294		
FP10B4HP-1	6U X 4HP	10.309	0.788	10.073	0.294	8.750	9.187
FP10B5HP-1	6U X 5HP		0.988		0.445		
FP10B8HP-1	6U X 8HP		1.588		0.294		
FP10B12HP-1	6U X 12HP		2.388		0.294		
FP15B4HP-1	9U X 4HP	15.559	0.788	15.323	0.294	14.000	14.437
FP15B5HP-1	9U X 5HP		0.988		0.445		
FP15B8HP-1	9U X 8HP		1.588		0.294		
FP15B12HP-1	9U X 12HP		2.388		0.294		

3U FRONT PLUG-IN CARDS, SEE SHEET 3 FOR 3U RTM (REAR TRANSITION MODULE)

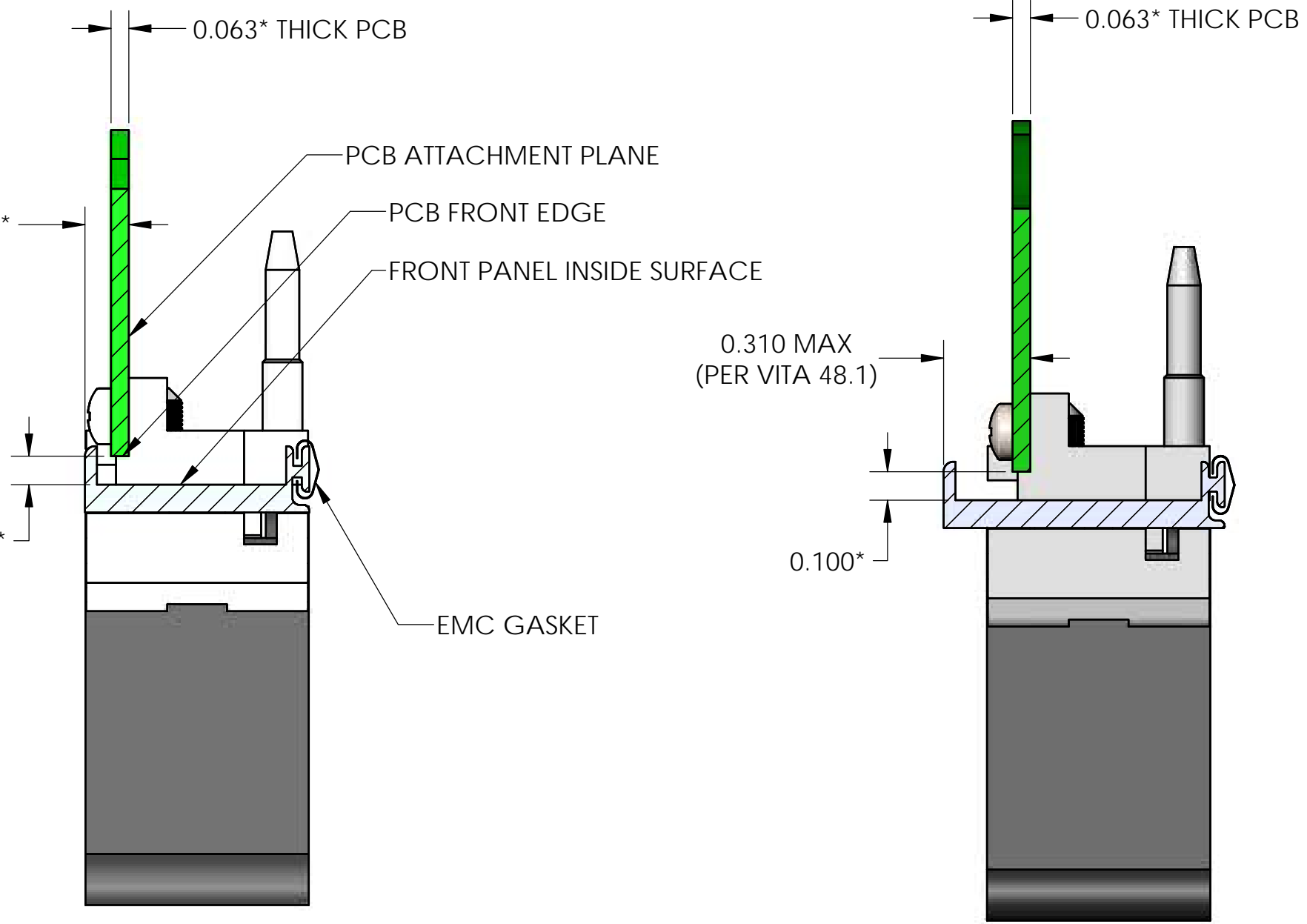
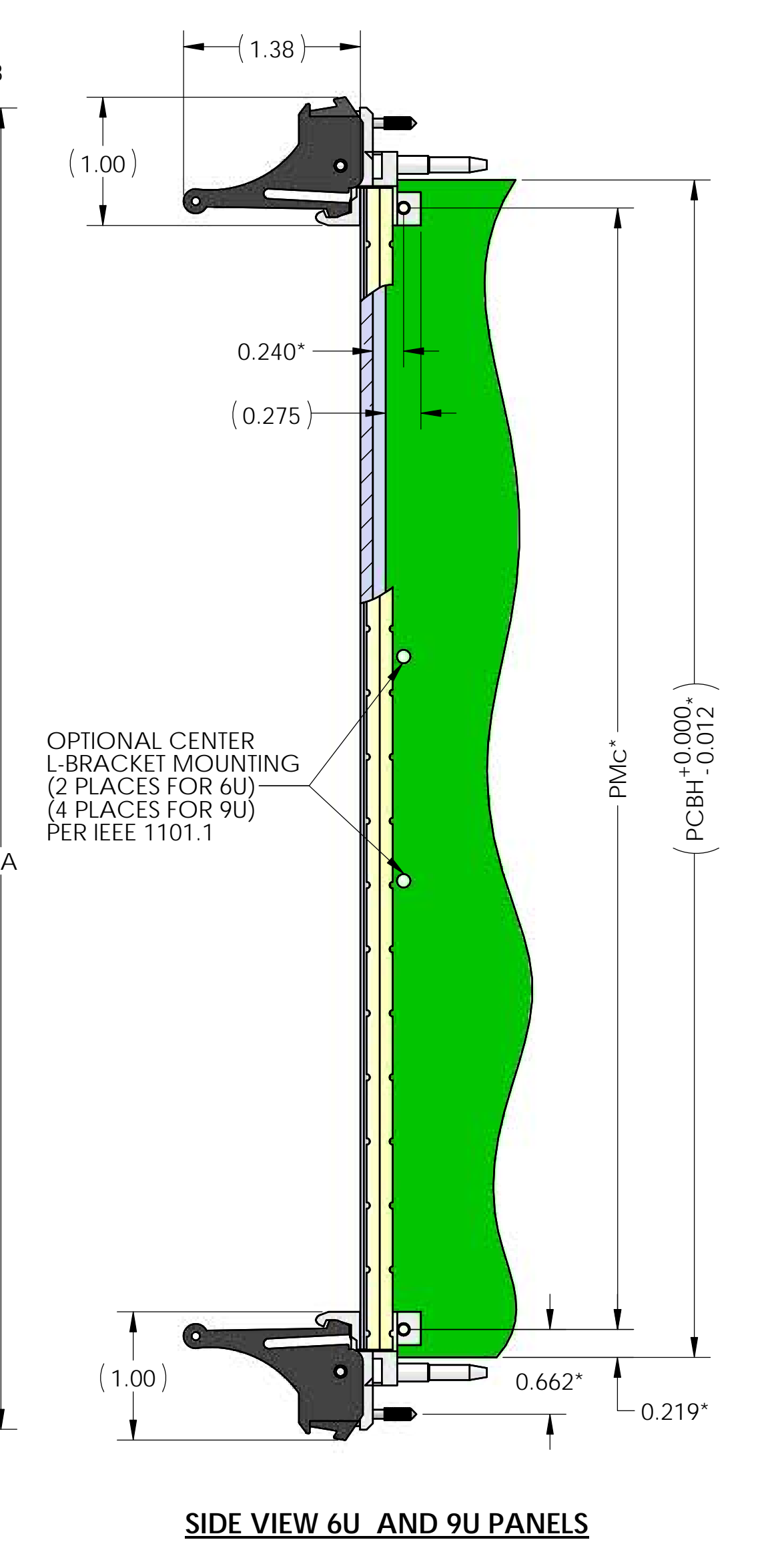
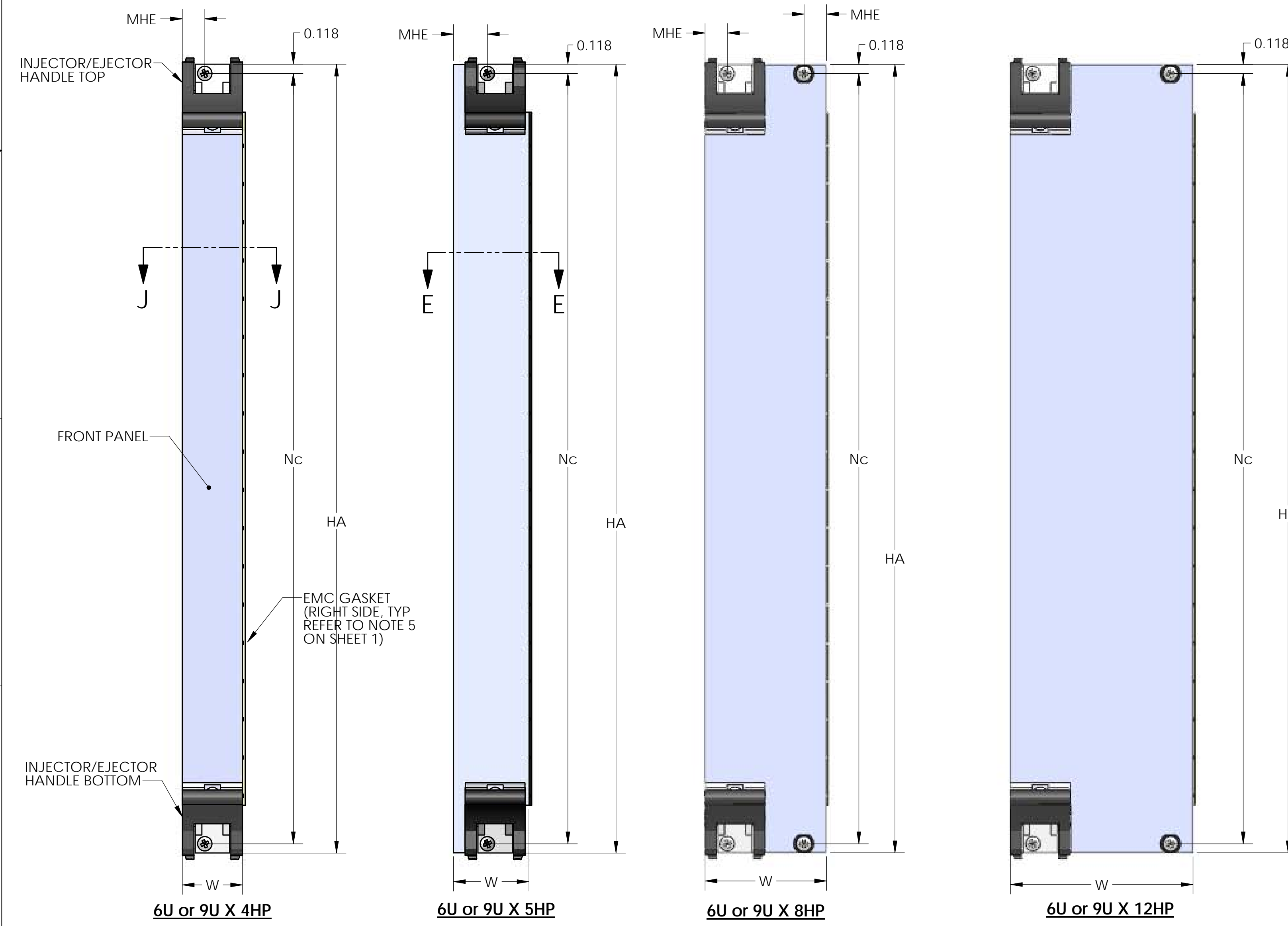

SECTION J-J FOR 3U, 6U, AND 9U 4HP, 8HP, 12HP WIDE PANELS. FRONT PLUG-IN CARDS. SCALE 2 : 1
 SECTION E-E FOR 3U, 6U, AND 9U 5HP WIDE PANELS. FRONT PLUG-IN CARDS. SCALE 2 : 1

6U/9U FRONT PLUG-IN CARDS AND RTM (REAR TRANSITION MODULE)

UNLESS OTHERWISE SPECIFIED: DIMENSIONS ARE IN INCHES TOLERANCES: DEC. X.X ±0.1 DEC. X.XX ±0.03 DEC. X.XXX ±0.010 FRACTIONS ±0.050 ANGLES ±1° THIRD ANGLE PROJECTION	NAME: TRISHAR DATE: 02/23/15	11115 VANOWEN ST. NORTH HOLLYWOOD, CA 91365 VECTOR ELECTRONICS & TECHNOLOGY, INC. www.vectorelec.com
MATERIAL: FINISH:	COMMENTS:	EMC FRONT PANEL, 1101.10 / 1101.11
SIZE: D	DWG. NO: FPXXBHP-1	REV: F
SCALE: 1:1 CAGE CODE: 82893 SHEET 1 OF 3		

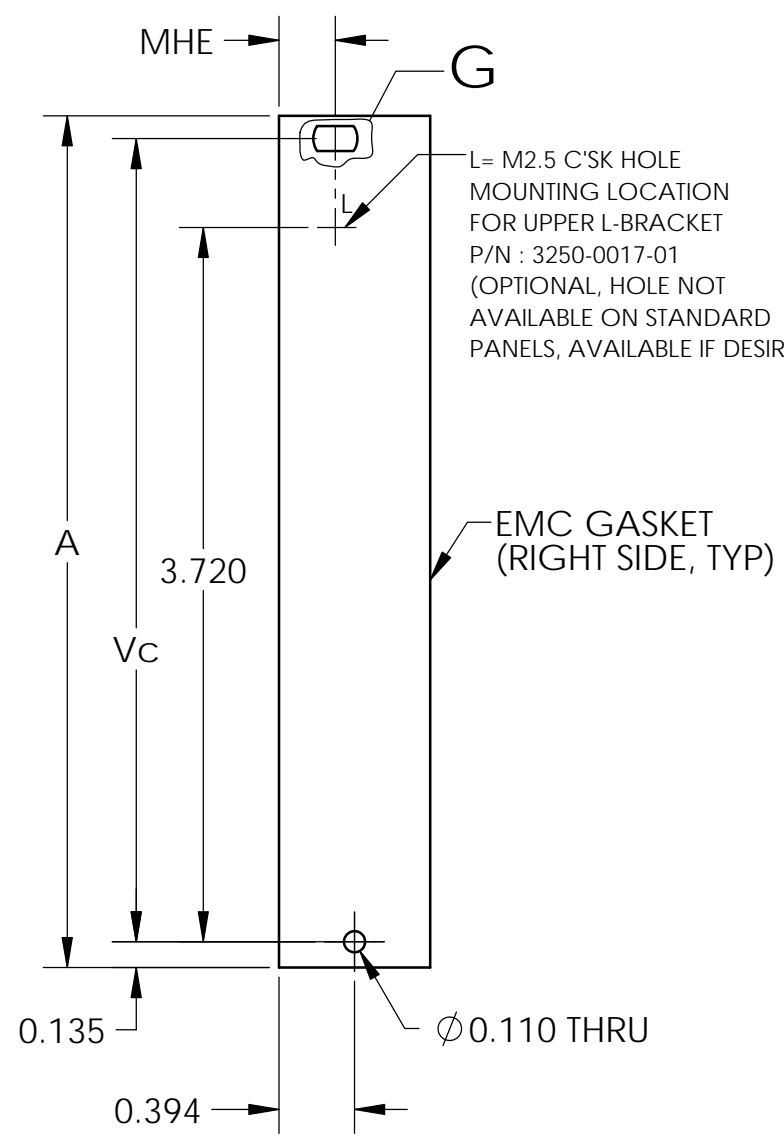

3U X 4HP

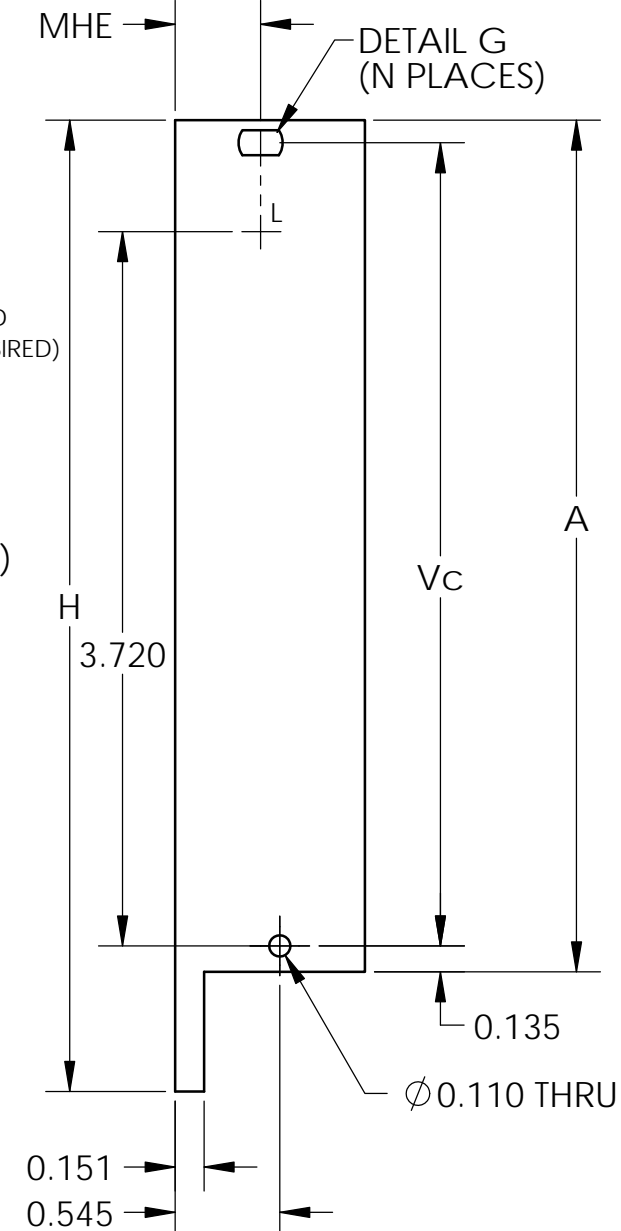

3U X 5HP

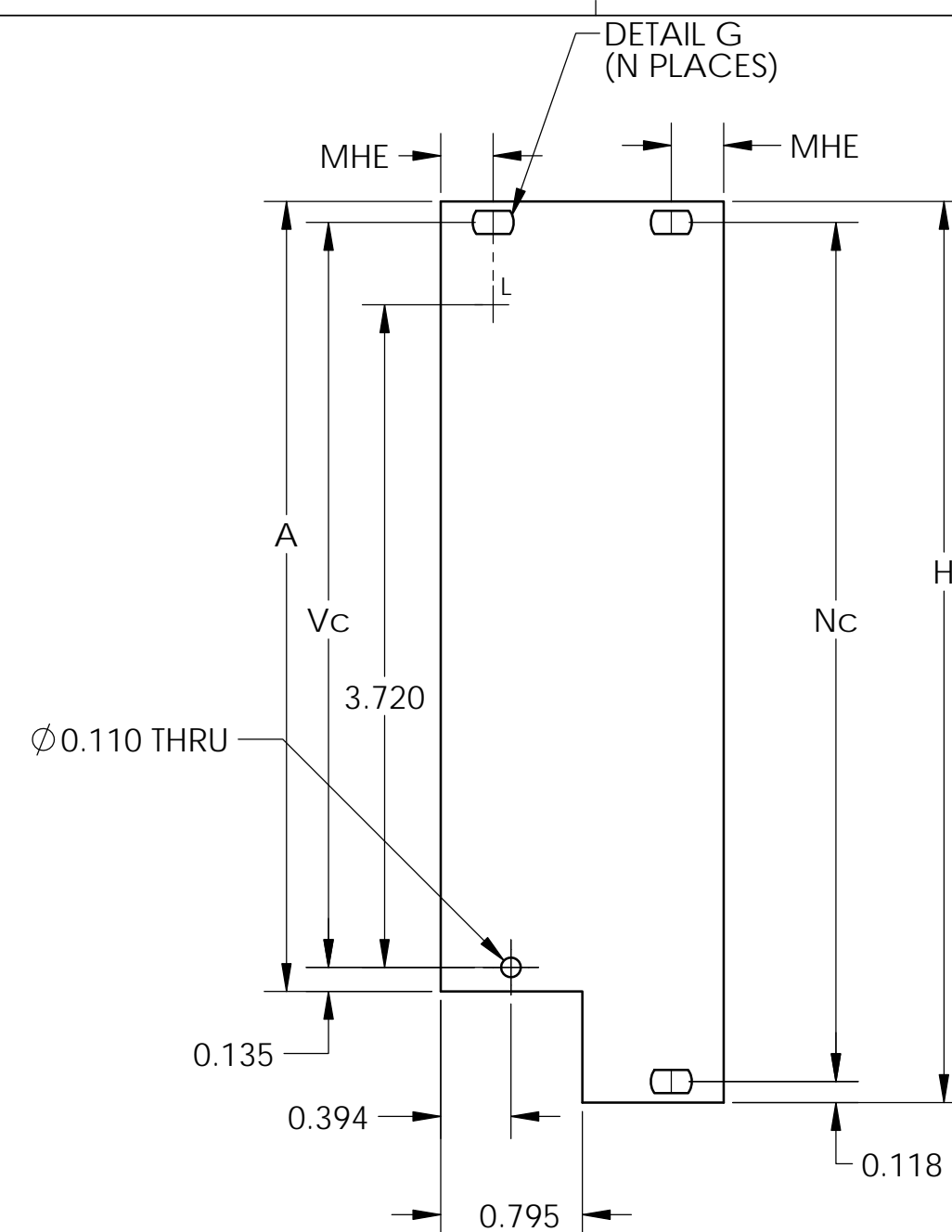

3U X 8HP

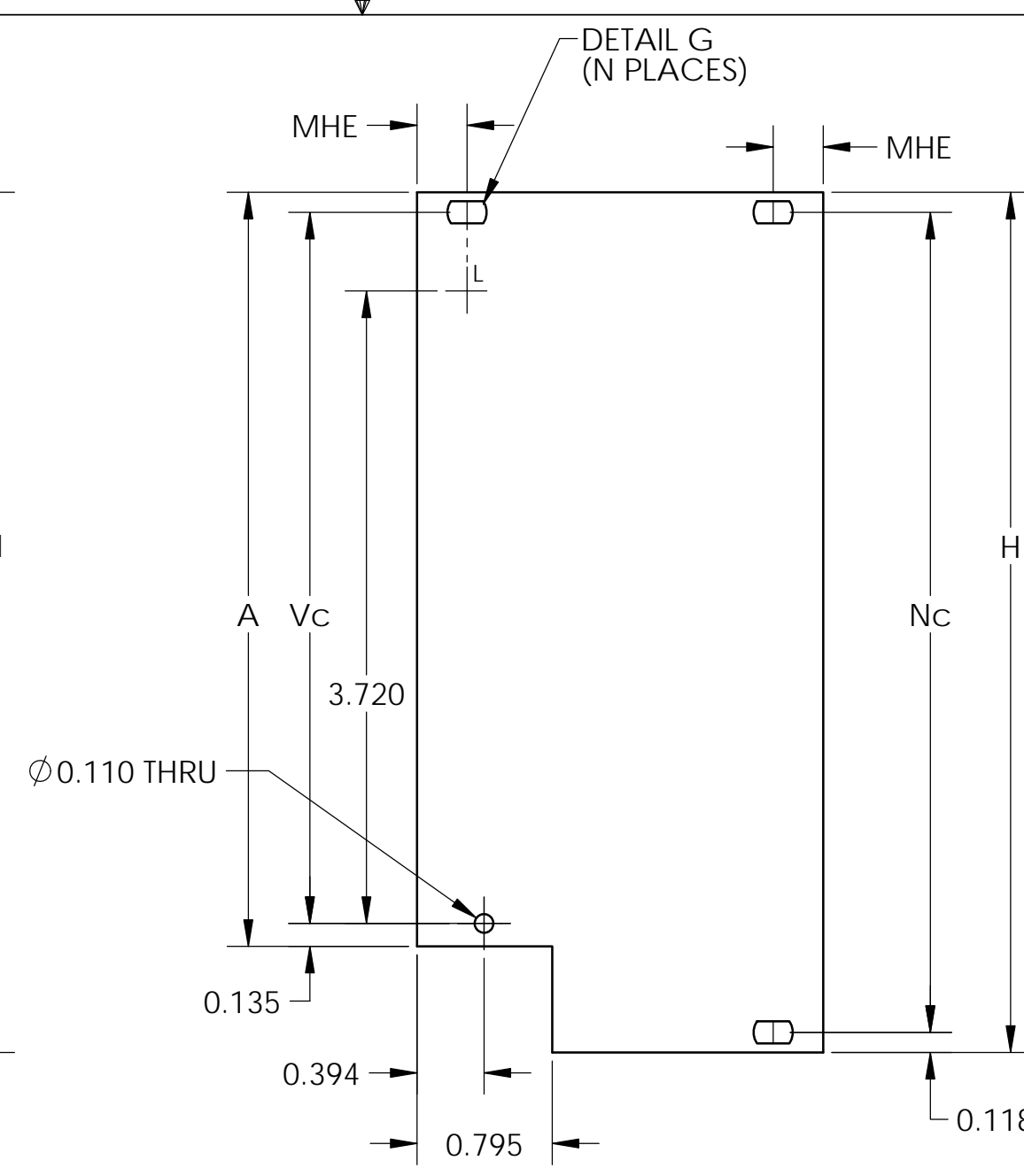

3U X 12HP

3U FRONT PLUG-IN CARDS, SEE SHEET 3 FOR 3U RTM (REAR TRANSITION MODULE)

- NOTES:
 1. MATERIAL : ALUMINUM EXTRUSION, 6063-T5
 2. FRONT SURFACE GRAINED IN DIRECTION OF MATERIAL GRAIN
 3. FINISH : CLEAR CHEM FILM, MIL-C-5541, CLASS 3

DIMENSIONS TABULATION									
PART NO	DESCRIPTION	H	W	MHE	Nc	Vc	A	PLACES N	
FP52B4HP-1	3U X 4HP	-	0.788	0.294	-	4.183	4.436	1	USE WITH FRONT PLUG-IN CARDS
FP52B5HP-1	3U X 5HP	5.059	0.988	0.445	-			1	
FP52B8HP-1	3U X 8HP	-	1.588	0.294	4.823			3	
FP52B12HP-1	3U X 12HP	-	2.388	0.294	4.823			3	
FP52B4HP-4	3U X 4HP	-	0.788	0.294	-	4.183	4.436	1	USE WITH RTM (REAR TRANSITION MODULE)
FP52B5HP-4	3U X 5HP	5.059	0.988	0.445	-			1	
FP52B8HP-4	3U X 8HP	-	1.588	0.294	4.823			3	
FP52B12HP-4	3U X 12HP	-	2.388	0.294	4.823			3	
FP10B4HP-1	6U X 4HP	-	0.788	-	-	8.793	9.063	-	USE WITH FRONT AND RTM PLUG-IN CARDS
FP10B5HP-1	6U X 5HP	10.309	0.988	-	-			-	
FP10B8HP-1	6U X 8HP	-	1.588	0.294	10.073			2	
FP10B12HP-1	6U X 12HP	-	2.388	0.294	10.073			2	
FP15B4HP-1	9U X 4HP	-	0.788	-	-	14.043	14.313	-	USE WITH FRONT AND RTM PLUG-IN CARDS
FP15B5HP-1	9U X 5HP	15.559	0.988	-	-			-	
FP15B8HP-1	9U X 8HP	-	1.588	0.294	15.323			2	
FP15B12HP-1	9U X 12HP	-	2.388	0.294	15.323			2	

ADD SUFFIX "-SS" TO PART NO FOR FRONT PANEL KIT WITH METAL PRESS-FIT SLEEVES INSTEAD OF PLASTIC SLEEVE. FOR EXAMPLE FP52B4HP-1-SS.
 PLEASE NOTE "-SS" OPTION IS NOT AVAILABLE IN FP10B4HP-1, FP10B5HP-1, FP15B4HP-1, FP15B5HP-1

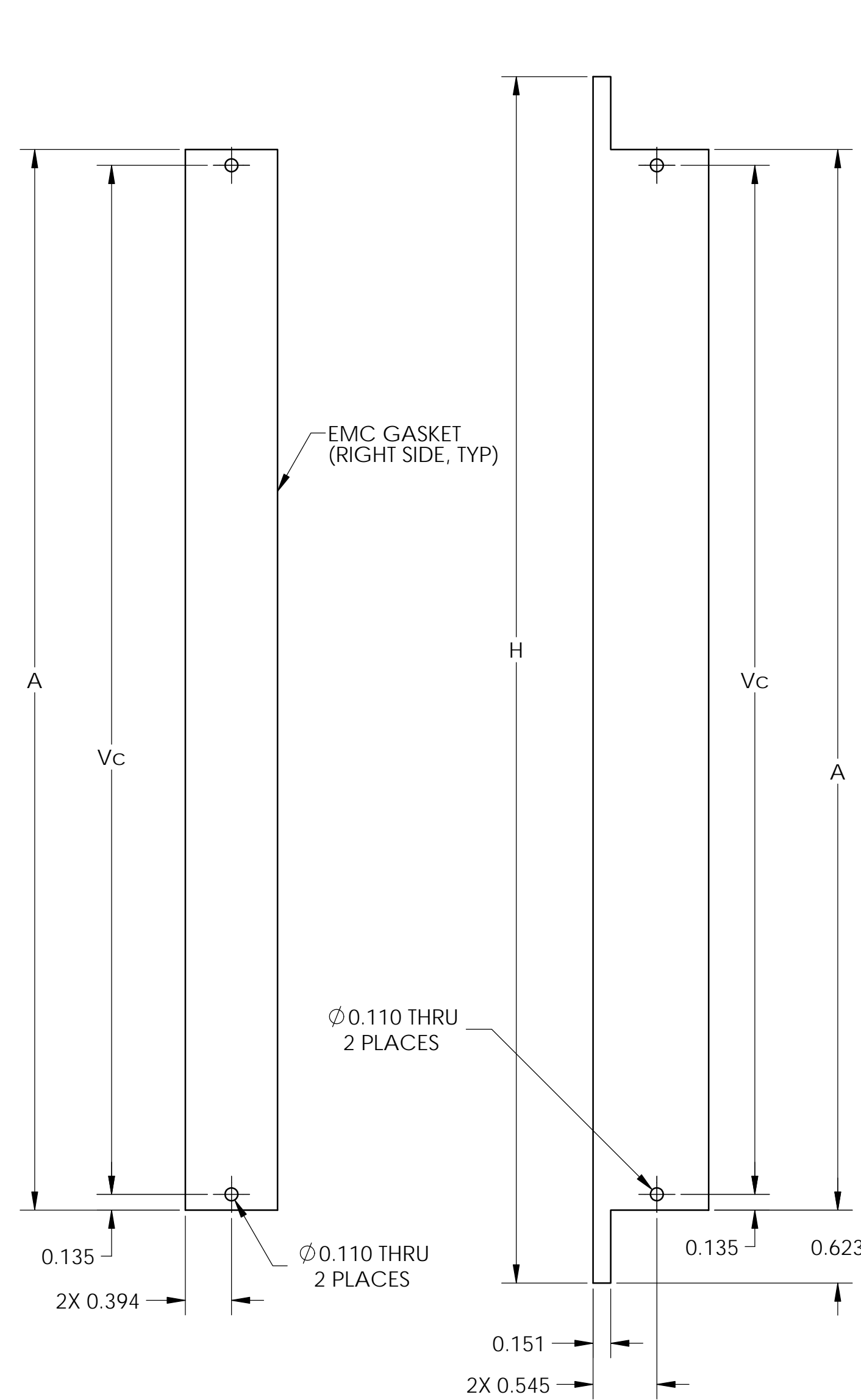

6U or 9U X 4HP

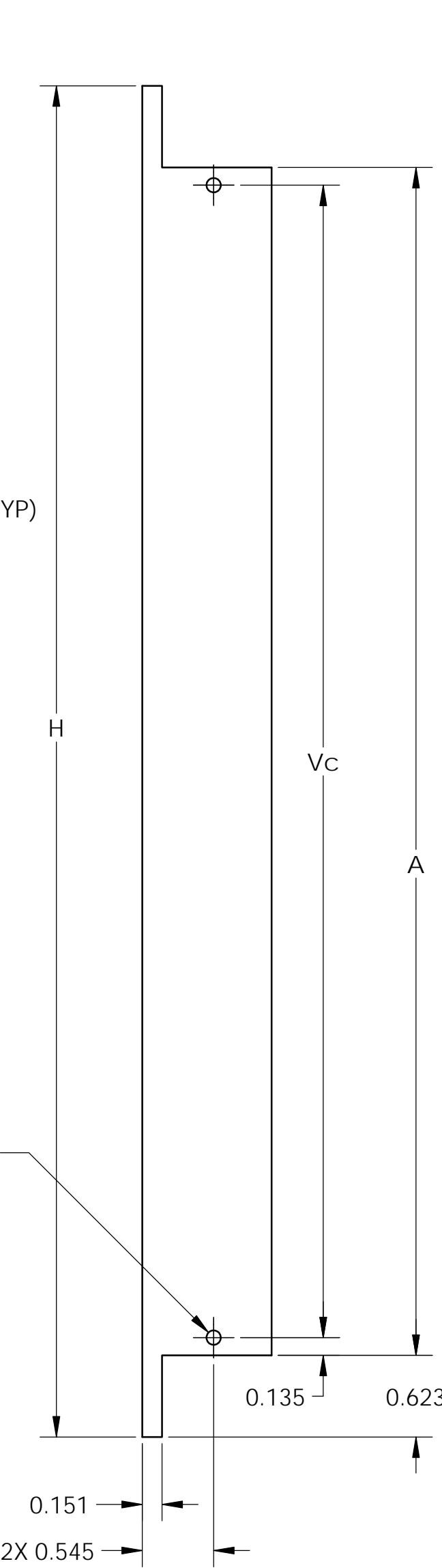

6U or 9U X 5HP

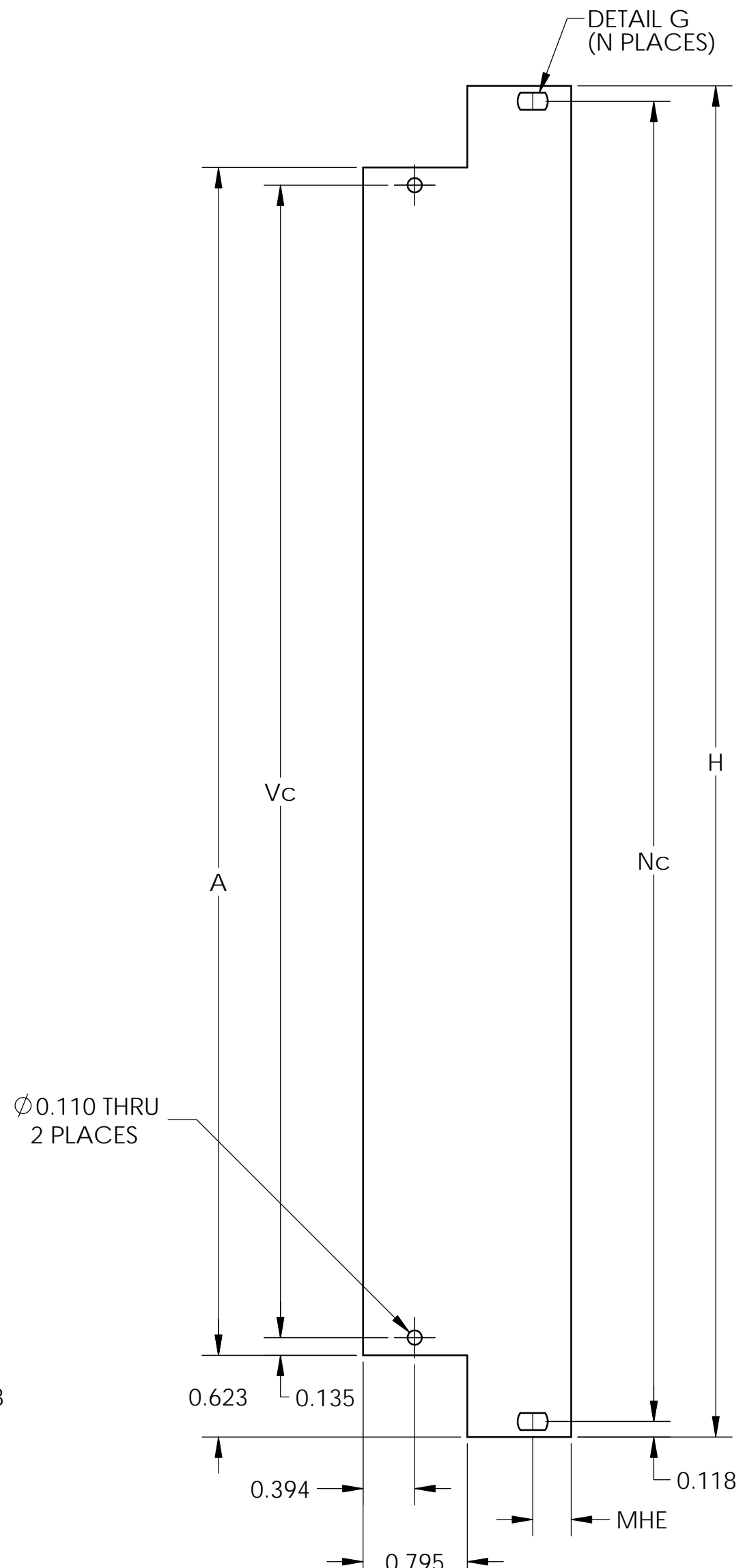

6U or 9U X 8HP

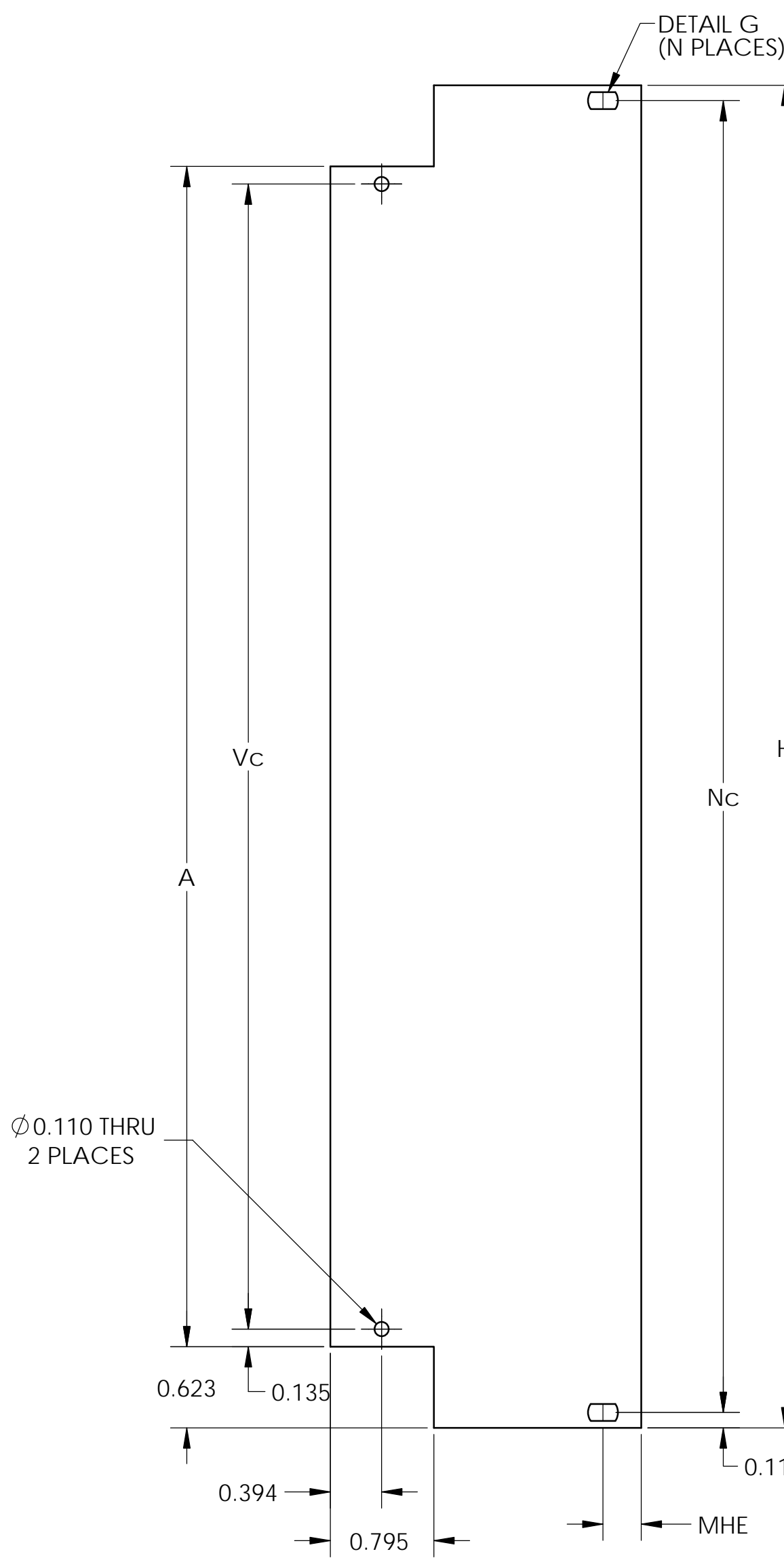

6U or 9U X 12HP

6U/9U FRONT PLUG-IN CARDS AND RTM (REAR TRANSITION MODULE)

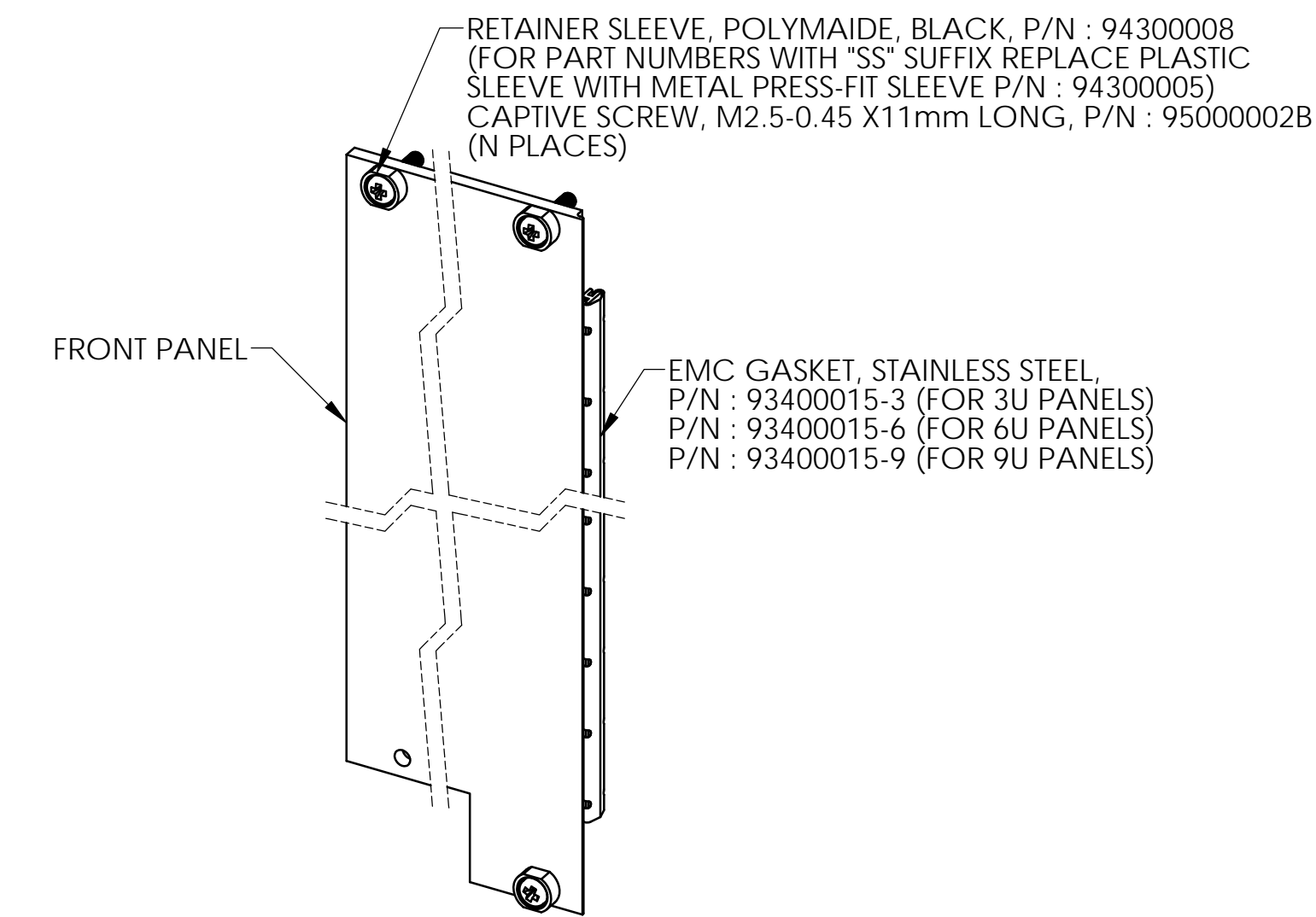

FPXXAXHP-1 FRONT PANEL ASSY

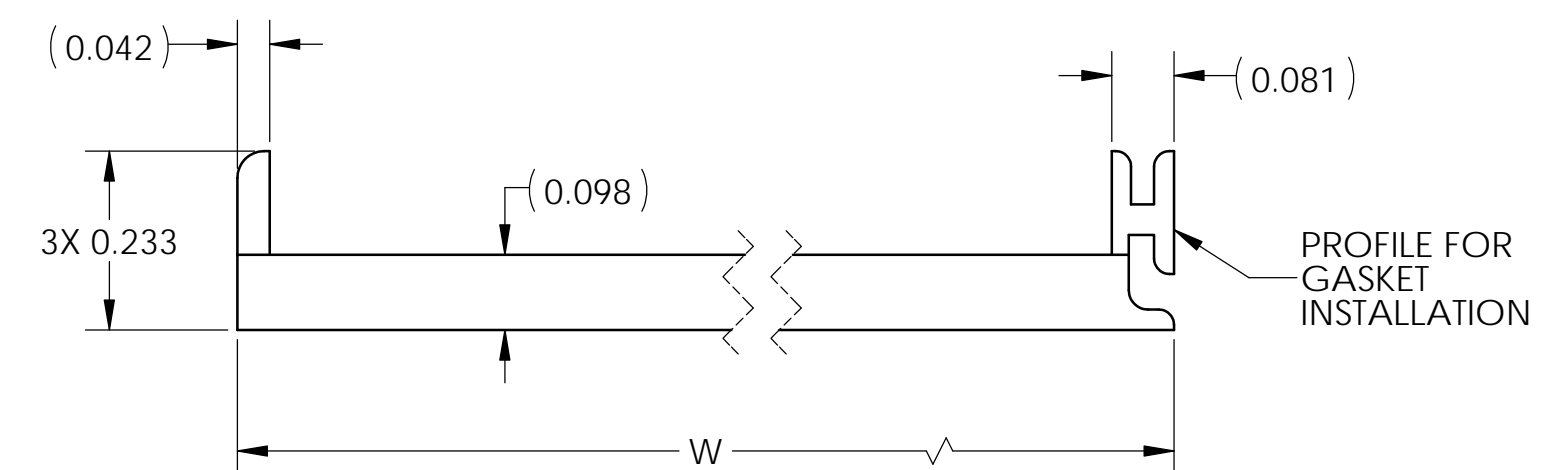

PANEL PROFILE DETAIL

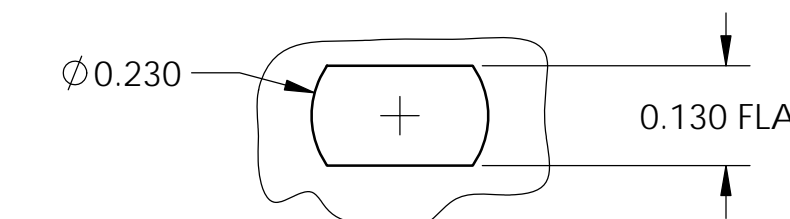

DETAIL G
SCALE 4 : 1

VECTOR ELECTRONICS & TECHNOLOGY, INC. 11115 VANOWEN ST., NORTH HOLLYWOOD, CA 91605 www.vectorinc.com

EMC FRONT PANEL, 1101.10 / 1101.11

SIZE	DWG. NO.	REV
D	FPXXBXHP-1	F

SCALE: 1:1 CAGE CODE: 82893 SHEET 2 OF 3

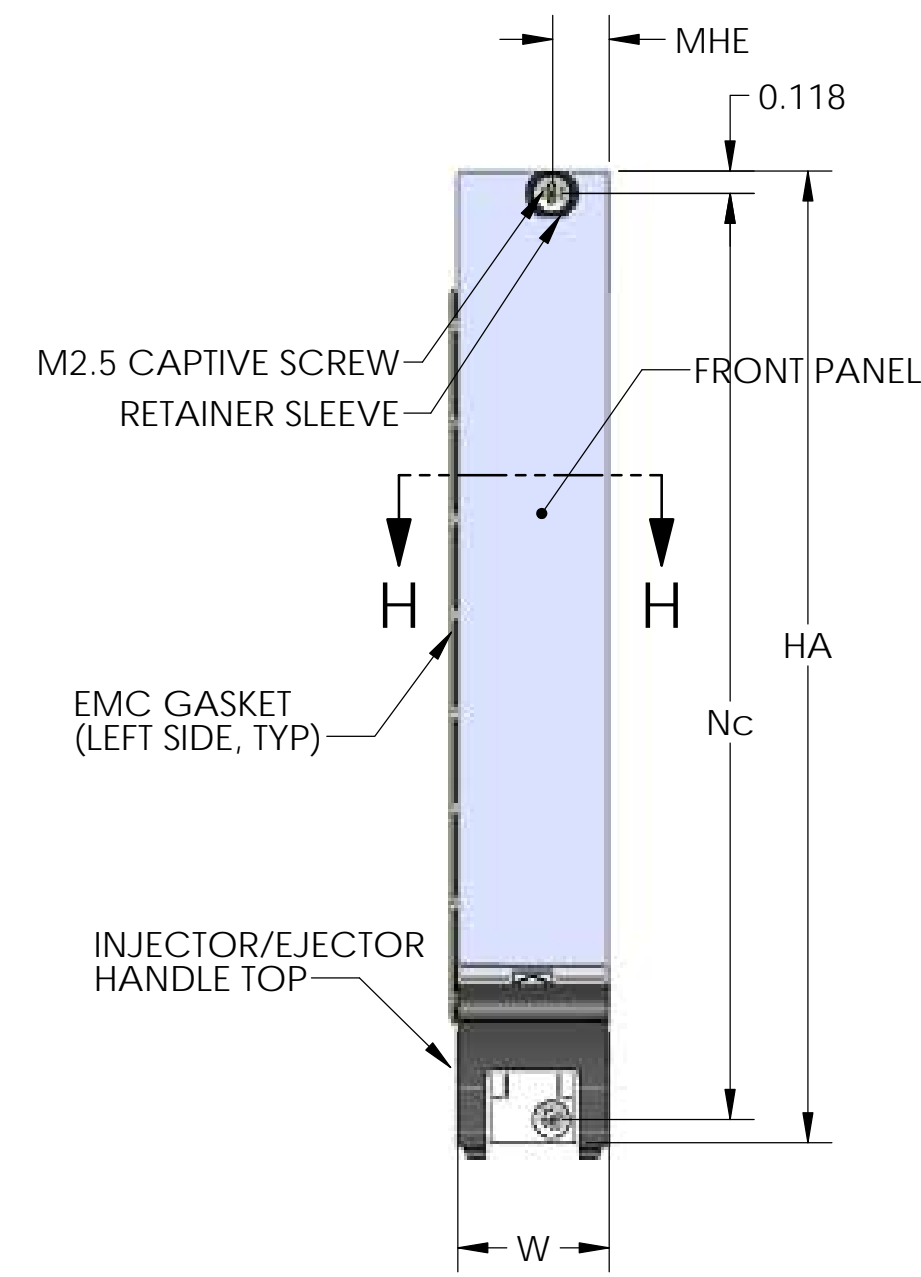

3U X 4HP

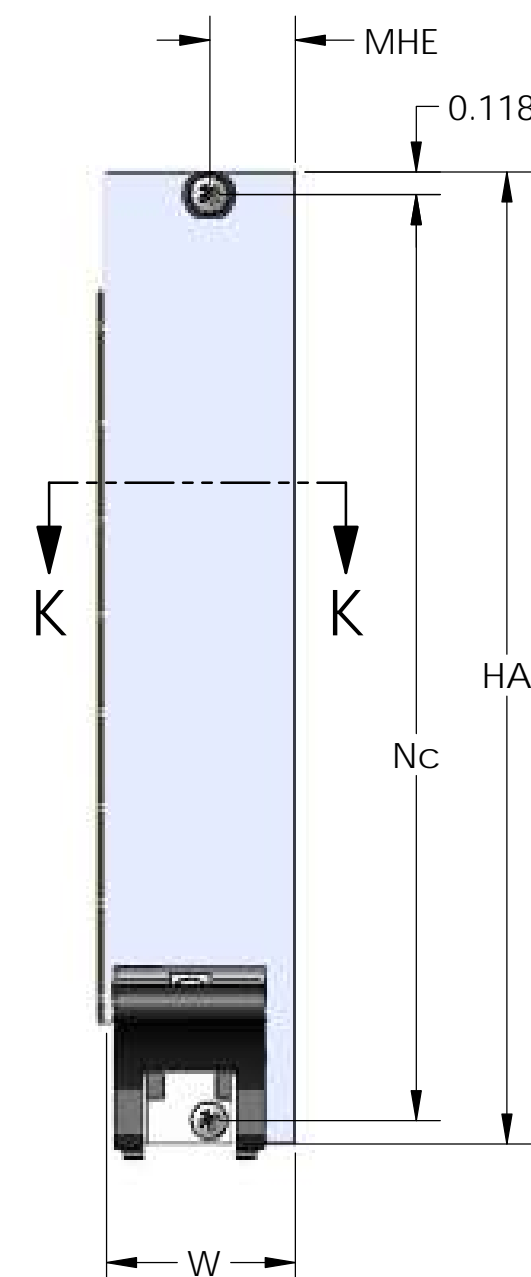

3U X 5HP

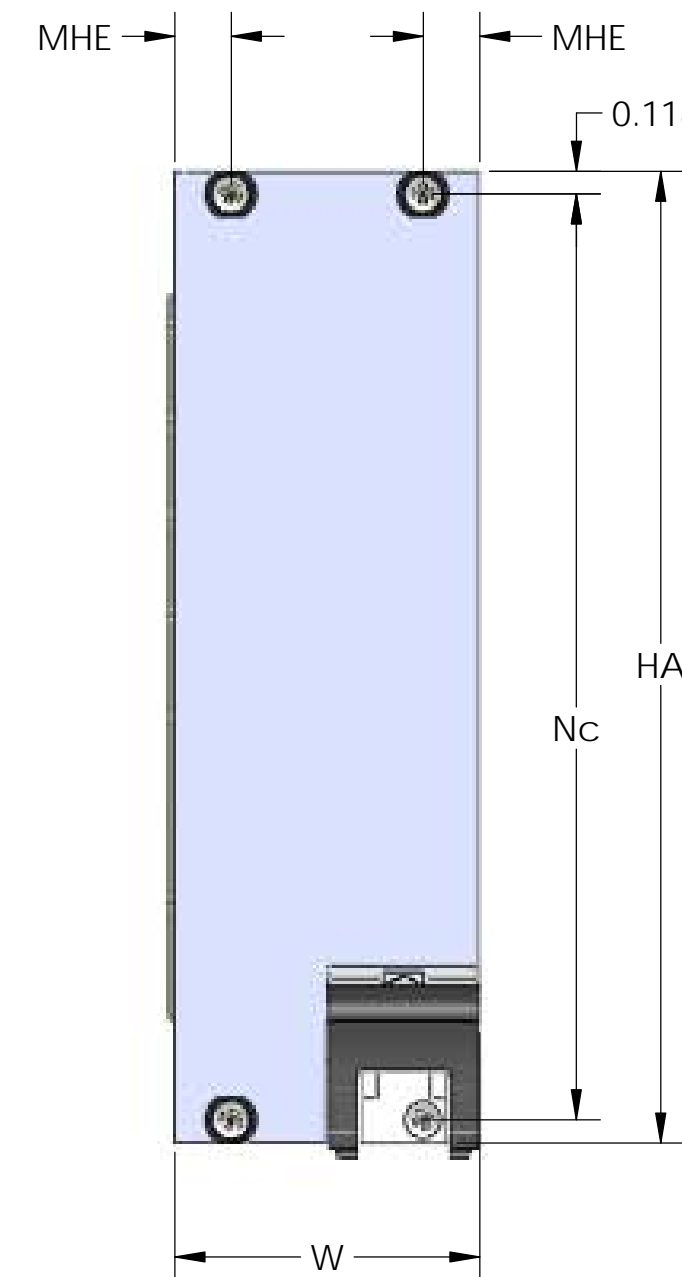

3U X 8HP

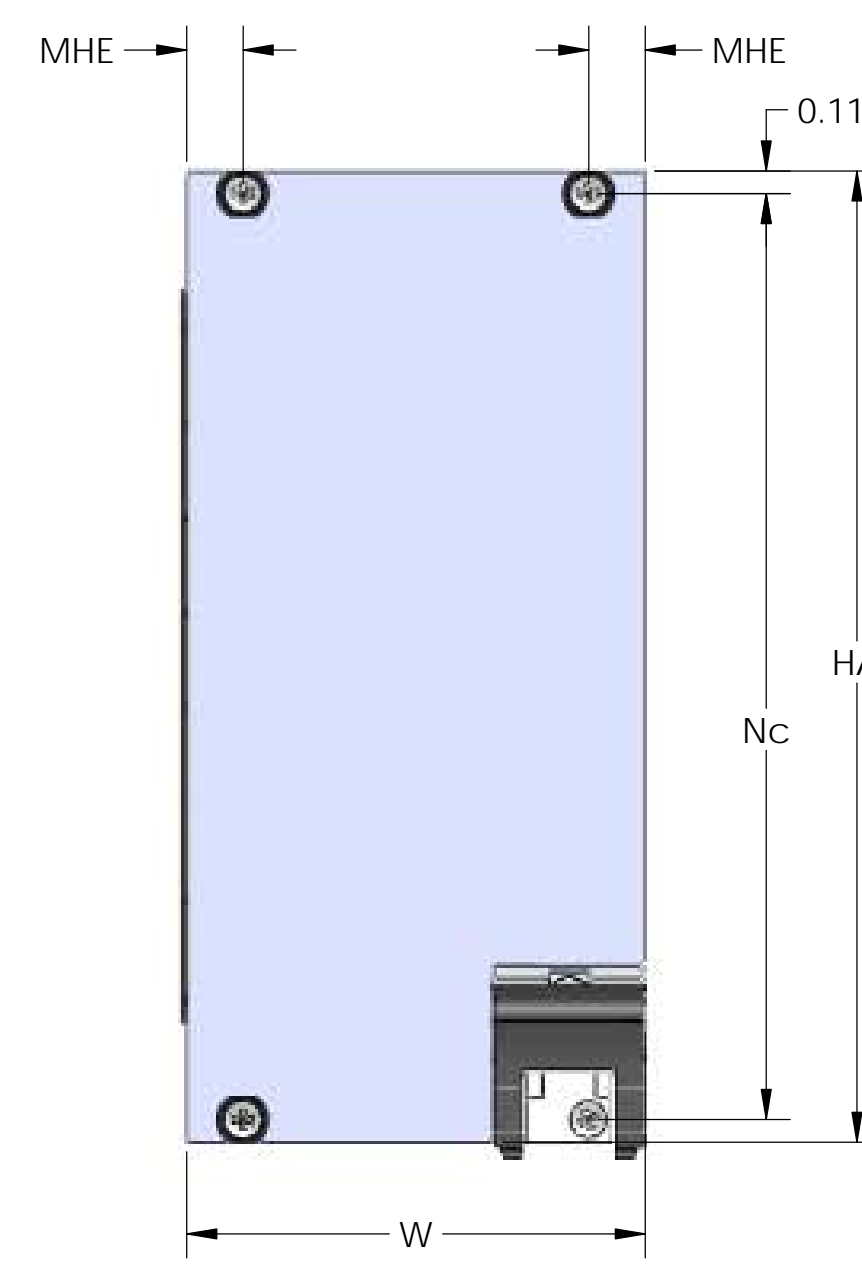

3U X 12HP

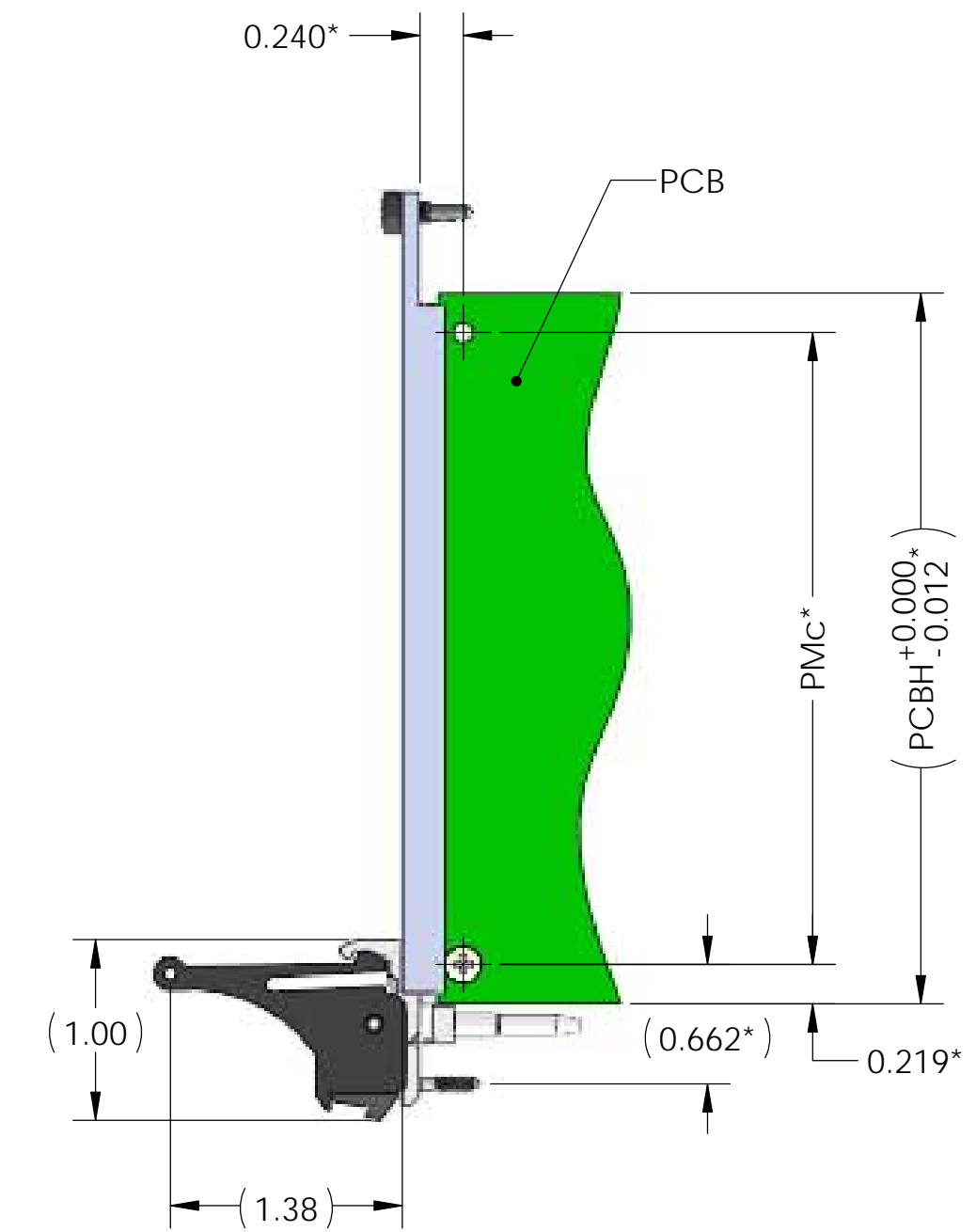

SIDE VIEW 3U PANELS

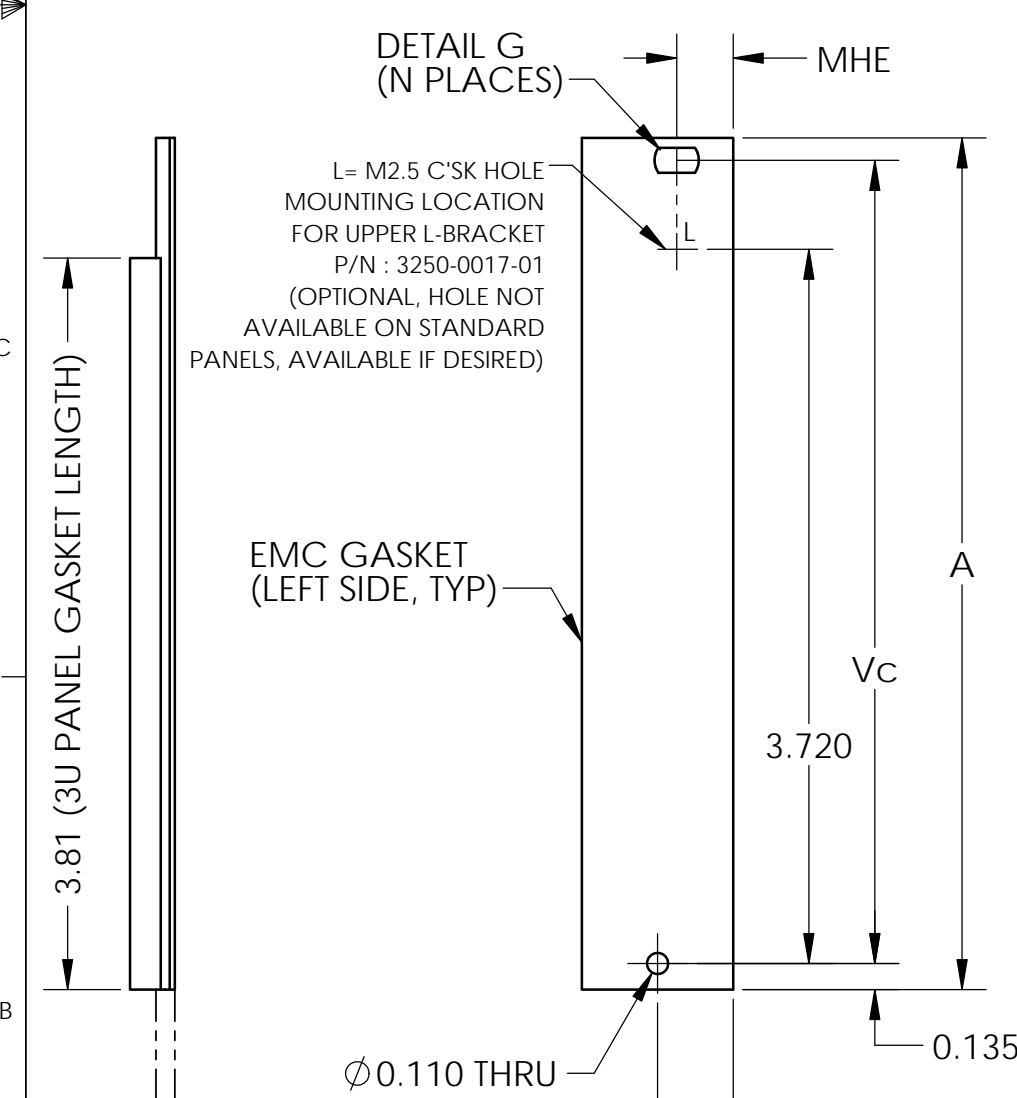

3U X 4HP

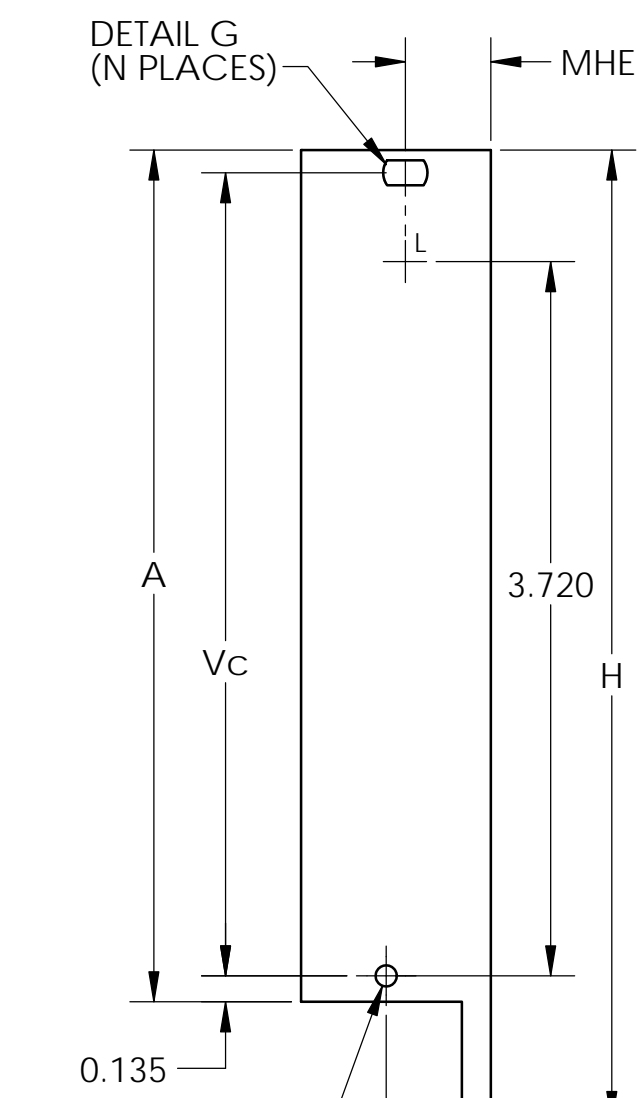

3U X 5HP

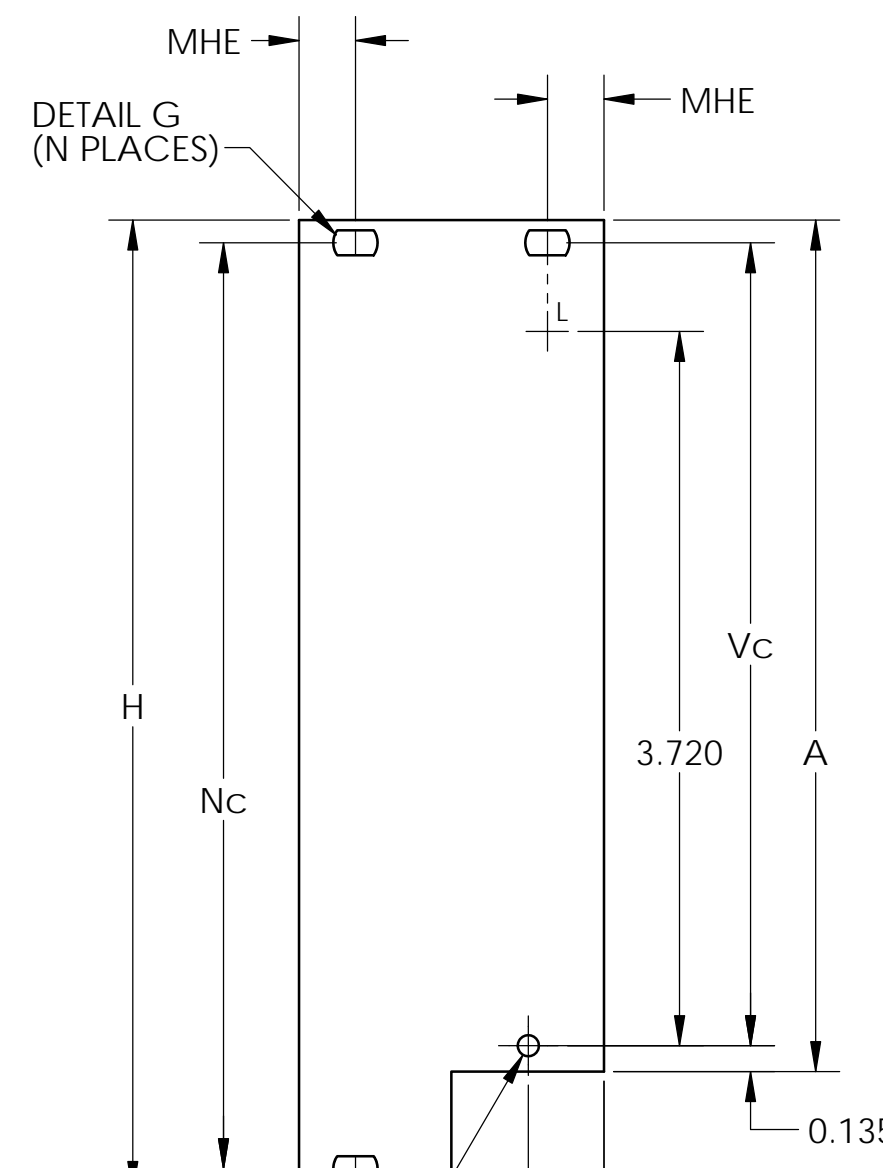

3U X 8HP

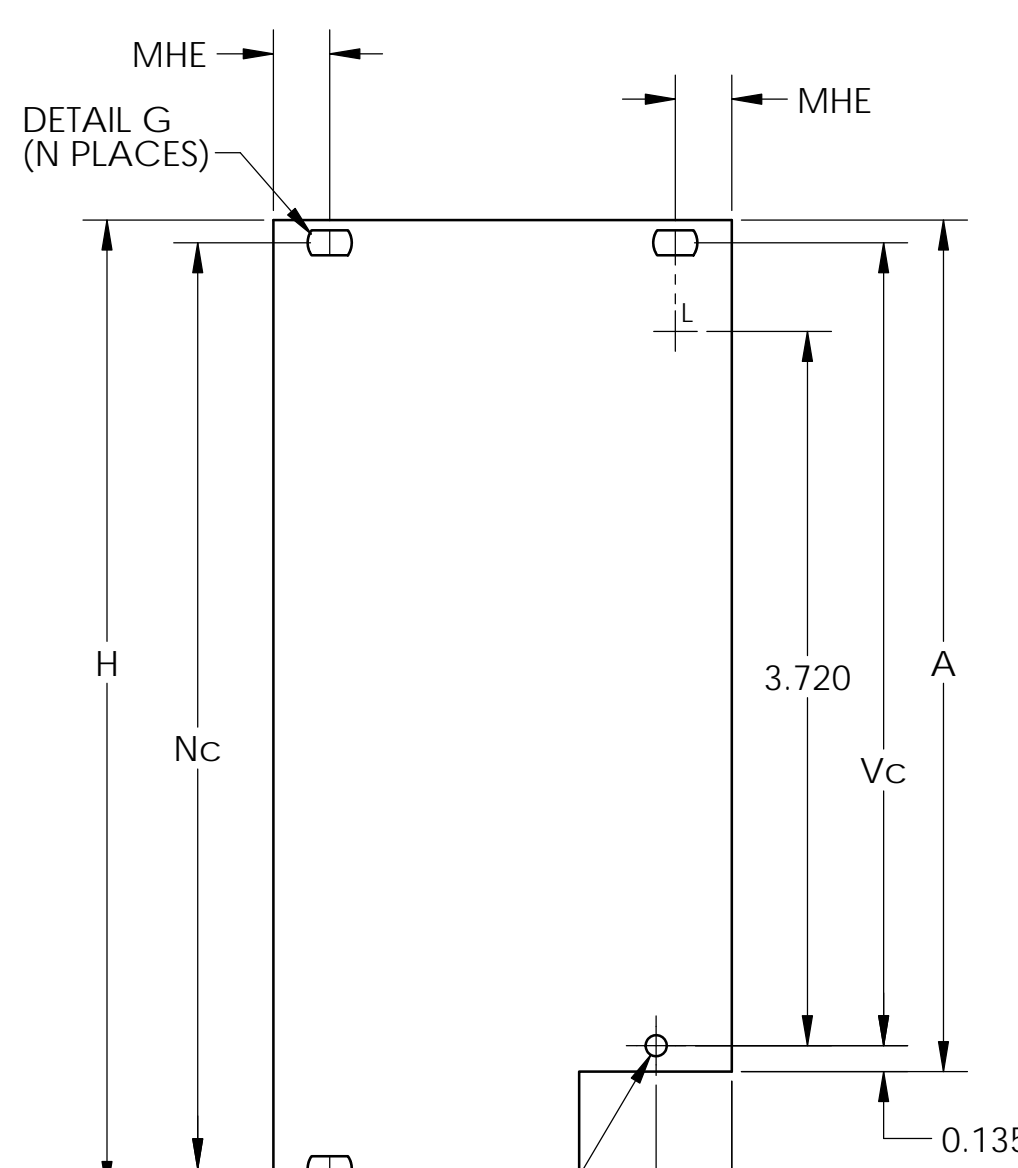

3U X 12HP

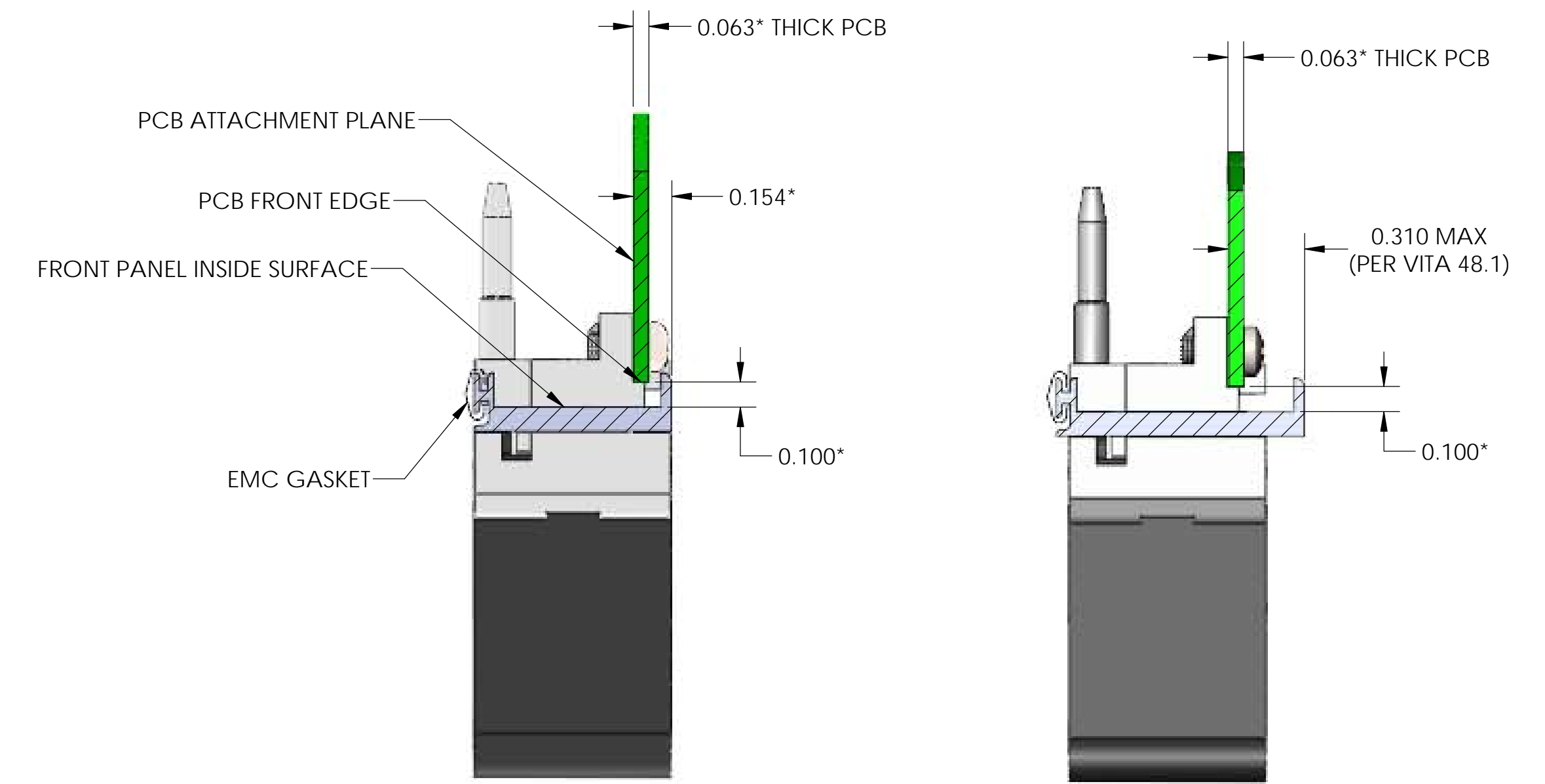

**SECTION H-H
FOR 3U, 6U, AND 9U
4HP, 8HP, 12HP WIDE PANELS.
RTM PLUG-IN CARDS.
SCALE 2 : 1**

**SECTION K-K
FOR 3U, 6U, AND 9U
5HP WIDE PANELS.
RTM PLUG-IN CARDS.
SCALE 2 : 1**

3U RTM (REAR TRANSITION MODULE) PLUG-IN CARD