

THERMA-FUSER™

EL - DDC INTEROPERABLE LINEAR VAV DIFFUSER

INSTALLATION, BALANCING & MAINTENANCE



Table Of Contents

INSTALLATION INSTRUCTIONS.....	2
CONNECTING WIRING	2
NETWORK CREATION AND COMMISSIONING OF EL DIFFUSERS	2
CREATE A LONMAKER NETWORK.....	3
INTRODUCE THE EL TO LONMAKER NETWORK.....	3
CREATE LONMAKER FUNCTIONAL BLOCK	3
CONFIGURE THE EL.....	4
POWER FAILURE.....	7
BINDING NETWORK VARIABLES.....	7
PUTTING THE EL IN OPERATING MODE.....	7
AIR DENSITY COMPENSATION.....	7
SYSTEM AIR BALANCING	7
TROUBLE SHOOTING	8
MAINTENANCE	11
CONTROLLING THE SYSTEM.....	11
MEASURING ENERGY CONSUMPTION.....	15
TWO YEAR WARRANTY	15

DAMAGED FREIGHT CLAIM PROCEDURE

When the diffusers are received, inspect for damage, which may have occurred during shipment. If damage is evident, it should be noted on the carrier's freight bill. A written request for inspection by the carrier's agent should be made at once.

STORAGE

Cartons should always be stacked on end. Do not stack cartons flat on the sides. Excessive weight may cause damage to the diffusers.

Do not store for prolonged times at temperatures exceeding 130°F(56°C). Acceptable humidity level 5-95% relative humidity noncondensing.

IDENTIFICATION

Models are factory shipped one per carton. The model designation is on the diffuser and on the carton.

INSTALLATION PRECAUTIONS

When installing diffusers make sure construction debris does not enter the diffuser or duct system.

Because the EL controls room temperature by sensing the room air induced up from the room, care should be taken not to disturb room air induction and entrainment

POWER REQUIREMENTS

24⁺³/₋₂VAC 18VA min.

INSTALLATION INSTRUCTIONS

- inspect the carton for damage before opening. Notify carrier if external damage exists. Submit all claims for shipping damage to the carrier.
- Move cartons to installation area. Note unit identification.
- Remove cardboard box and cardboard insert. Discard packing material.
- Connect and secure the supply duct to the collar. Flexible duct should NOT be formed in less than one diameter turn.
- Connect twisted pair network wiring to either screw terminals or RJ 45 jacks. For daisy chaining connect both input and output leads to screw terminals or use one RJ 45 jack for input and the other for output.
- Connect 24 VAC power to the screw terminal labeled 24 VAC.
- Commission all EL diffusers. See 'Network Creation and Commissioning of EL Diffusers'.
- Balance the system. See 'System Air Balancing'

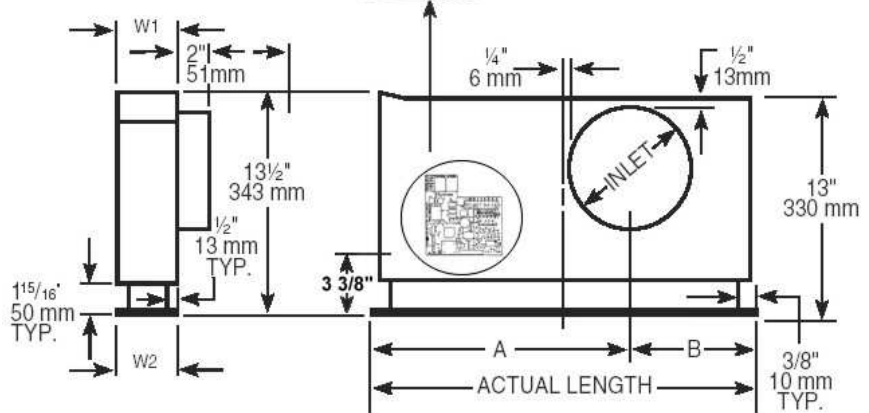
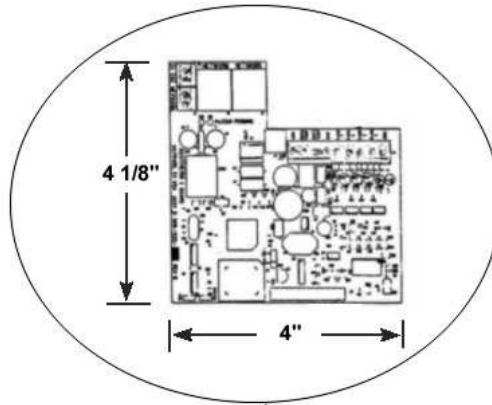

ONE AND TWO SLOT						W2	
NOMINAL LENGTH	ACTUAL LENGTH	INLET	A	B	W1	2SLOT 1WAY	2SLOT 2WAY
36"	35 3/4"	5 7/8"	21 1/16"	14 11/16"	4"	3 3/4"	4 "
48"	47 3/4"	7 7/8"	28 1/16"	19 11/16"	4"	3 3/4"	4 "
FOUR SLOT						W2	
NOMINAL LENGTH	ACTUAL LENGTH	INLET	A	B	W1	4SLOT1 WAY	
48"	47 3/4"	9 7/8"	28 1/16"	19 11/16"	6 5/16"	6"	

CONNECTING WIRING

See detail above. The following steps are performed on each EL that is physically on site. If you are building the network off site, these steps are completed after mechanical installation and during network commissioning.

- Connect network cable to the EL 'Network' terminals. Two wires are required. A twisted pair is most commonly used. The free topology FTT-10 transceiver can be used in bus, loop, star and daisy chain topologies. Two RJ-45 terminals and one screw terminal on the EL allow for daisy chaining or temporarily connecting to a computer.
- Connect 24 VAC to the '24 VAC' terminal of the EL.

NETWORK CREATION AND COMMISSIONING OF EL DIFFUSERS

Download the XIF file from Acutherm web site: www.acutherm.com.

This part of the document is prepared only for users having LonMaker For Windows as the network management tool. Please refer to the specific user's guide if you have other network management software. Refer to the LonMaker User's Guide and the LonMaker For Windows help file.

Create a LonMaker Network

1. To create a new network:
From Windows desktop click on Start -> Programs -> LonMaker For Windows.
From the first window screen of LonMaker click on the 'New Network' button then enter the new network name in the 'Network Name' field. Accept the default values for the 'Network Database Path' and 'Network Drawing Path' then click on 'Next' and go to step 4.
2. To open an existing network:
From Windows desktop click on Start -> Programs -> LonMaker For Windows.
From the drop down list in the 'Drawing Directory' field, choose the network you want to open, then click on 'Open Network'.
3. In the 'Network Interface' window, select 'Network Attached' if the PC is attached to the physical network and you want to communicate with the devices. Accept the default 'Network Interface' or choose the appropriate network interface if you have more than one network interface in your PC. Click 'Next'.
4. Enter your user name and password if required. Check the 'Write Access' box if you are going to make changes to the network.
5. If you are connected to the network, the 'Management Mode' window will appear. Check the 'OnNet' option if you want changes to be propagated immediately to the device. If the 'Offnet' option is checked, changes won't be propagated to the devices on the network until LonMaker is 'OnNet'. Click 'Next'.
6. The 'Plug-in Registration' window allows you to choose which plug-ins to register with this network. Click 'Finish'.

Introduce The EL To LonMaker Network

1. Place a 'Device' shape on the drawing by dragging it from the LonMaker basic shapes stencil.
2. The 'New Device Wizard' window appears. Provide a 'Device Name' and select 'Commission Device' if LonMaker is in the 'Online' mode. Press 'Next'.
Note: If EL devices are added to the network in 'Offline' mode or 'Commission Device' option is not selected, a 'Configuration Properties Warning' box is displayed with the following contents: 'There are no default configuration properties available for this device. If this device was previously installed in another system, its configuration properties values may need to be reset'. Click OK.
3. The 'Specify Device Template' window appears. If the EL being added is the first, check the 'Load XIF' option and then select 'Browse.'
Note: The XIF file provides LonMaker For Windows information about the EL.
4. Navigate to the directory where the EL.XIF file is located then double click on it. You will be returned to the 'Select Device Template' window with the 'File' and 'Template Name' fields defined based on your selection. Press 'Next' to continue.
Note: If the EL being added has been placed on the drawing before, its template will already be available and can be accessed by checking the 'Existing Template' option. Then the 'Name' can be selected from the drop down list provided.
5. The 'Specify Device Channel' window appears. Select 'TP/FT-10' as the 'Xcvr Type' and if necessary select the appropriate channel from the 'Name' drop down list. Press 'Next' to continue.
6. The 'Specify Device Properties' window appears. Accept the default settings and press 'Next' to continue.
7. The 'Identify Device' window appears. You can choose either the 'Service Pin' or 'Manual' method of identifying the controller. Typically, the default service pin method is selected. Press 'Next' to continue.
8. The 'Specify Device Application Image Name' window appears. Typically no changes are required to this screen so press 'Next' to continue.
9. The window titled 'New Device Wizard' appears. This is when you define the state of the device and the source of the configuration property values. Select 'Online' for the state and 'Default values' for the source of the configuration properties values. Press 'Next' to continue.
10. A screen appears prompting for a service pin. (See sketch, p. 10) Press the service pin on the EL to finish the commissioning process. In the project drawing, the device shape should now be green indicating it is addressed and online.

Create LonMaker Functional Block

1. A functional block represents a collection of network variables and configuration properties that perform a related function on a device. To create functional blocks for the EL:
2. Place a Functional Block shape on the drawing by dragging it from the LonMaker Basic Shapes stencil. The 'New Functional Block Wizard' window appears. This is where the device and functional block instances are selected. In the 'Device' area, set the 'Name' of the EL associated with this functional block. In the 'Functional Block' area, set the 'Name' of the functional block to 'Virtual Functional Block'.

Configure The EL

The EL unit is shipped with the default values shown below. When configuring, review the default values and change only what is necessary:

Configuration Variables

Function	Description	Symbol On Screen (SCPTs, SNVTs)	Default value	Range Available
Occupancy Temperature Setpoint	The temperature setpoint of the space to be maintained by the EL for the occupancy modes: occupied, unoccupied, standby.	SCPTsetPnts	¹ 23°C (73.4°F), 25°C (77°F), 27°C (80.6°F), 21°C (69.8°F), 19°C (66.2°F), 16°C (60.8°F)	50 – 95F (10 –35C)

¹ This variable consists of six fields: Occupied cool, standby cool, unoccupied cool, occupied heat, standby heat, unoccupied heat

Function	Description	Symbol On Screen (SCPTs, SNVTs)	Default value	Range Available
Location Label	This is designation for the space in which the EL is located, i.e. Conf Rm 12	SCPTlocation	Blank	Max length: 31 characters
Maximum Flow	Reserved for future use.	SCPTmaxFlow	65535 l/s	Do not change from factory default setting.
Occupancy Bypass Time	The amount of time in seconds the EL operates in occupied mode when the occupancy input is set to OC_BYPASS.	nciOccBypassTime	30	6553.4 secs.
Operation Mode	Configures the EL to operate in cooling only or heat and cool mode.	nciHeatCoolMode	HVAC_AUTO	HVAC_AUTO, HVAC_HEAT, HVAC_COOL, HVAC_MRNG_WRMUP, HVAC_NIGHT_PURGE
Receive Heartbeat	The maximum time that elapses after the last update to a bound network input before the VAV object adopts a default value for the following: nviSpaceTemp, nviSetpointOffset, nviApplicMode, nviEnergyHoldOff, nviCO2, nviDuctTempln	SCPTmaxRcvTime	0	0 sec – 6553.4 sec
Send Heartbeat	The maximum period of time that expires before the following network variable outputs will automatically be updated: nvoSpaceTemp, nvoUnitStatus, nvoBoxFlow, nvoTerminalLoad, nvoEffectSetPt, nvoEnergyHoldff	SCPTmaxSendTime	0	0 sec – 6553.4 sec
Minimum Send Time	The minimum period of time between output network variable transitions.	SCPTminSendTime	0	0 sec – 6553.4 sec

Minimum Flow	Reserved for future use.	SCPTminFlow	0	Do not change from factory default setting.
Minimum Flow Standby	Reserved for future use.	SCPTminFlowStby	0	Do not change from factory default setting.
Duct Area	Reserved for future use.	SCPTductArea	0	Do not change from factory default setting.
CO2 Set point	Reserved for future use.	nciCO2Threshold	5000	Do not change from factory default setting.

Input Network Variables

Function	Description	Symbol On Screen (SCPTs, SNVTs)	Default value	Range Available
Space Temperature	Allows the EL to connect to a space temperature sensor other than the one installed in the EL.	nviSpaceTemp	327.67°C (621.806°F)	0 – 327.67°C (0 – 621.806°F)
Temperature Setpoint	Allows the temperature setpoint for the occupied and standby modes to be changed via the network. It is used to reset the temperature rather than change them.	nviSetPoint	327.67°C (621.806°F)	10 – 35°C (50 – 95°F)
Setpoint Offset	Shifts the temperature control point via the network. It is typically bound to a supervisory node providing outside air temperature compensation or to an external wall diffuser having a relevant setpoint knob. Operates only on occupied and standby setpoints.	nviSetPtOffset	No offset = 32°F/0°C	-10°C to 10°C (14°F to 50°F)
Occupancy	Commands the EL diffuser into different occupancy modes. It is typically set by a supervisory node.	nviOccCmd	OC_NUL	OC_OCCUPIED, OC_UNOCCUPIED, OC_BYPASS, OC_STANDBY, OC_NUL
Duct Inlet Temperature	Allows the EL to be used with another mfr's inlet temperature sensor	nviDuctInTemp	327.67°C (621.806°F)	10 – 49°C (50 – 120°F)
VAV Manual Override	Commands the controller into a manual mode	nviManOverride	HVO_OFF, 0.000, 0	² See below
Emergency Command	Commands the EL into different emergency modes. It is typically set up by a supervisory node.	nviEmergCmd	EMERG_NORMAL	EMERG_NORMAL, EMERG_PRESSURIZE, EMERG_DEPRESSURIZE, EMERG_PURGE, EMERG_SHUTDOWN, EMERG_NUL
Flow	Allows the EL to be used with another manufacturers flow sensor located on the network.	nviBoxFlow	65535 l/s (138862 cfm)	0 – 65535 l/s (0 – 138862 cfm)

Energy Hold-Off	Forces the EL into a lower energy consumption mode. For example, an opened window could close the diffuser in the cooling mode or cause the EL to go to the unoccupied setpoint if in the heating mode	nviEnergyHoldOff	0.0 0 (2 fields separated by a space)	0 to 100%, 0 or 1
Terminal Command Input	This input network variable is to be used for the trouble shooting purpose by manufacturer.	nviTermCmdIn	<blank>	N/A
CO2	Reserved for future use.	nviCO2	32767	Do not change from factory default setting.
Application Mode	The EL uses 'nciHeatCoolMode' instead	nviApplicMode	HVAC_AUTO	See nciHeatCoolMode

² This variable consists of three fields: state, percent, and flow.

Valid range

State : HVO_OFF, HVO_POSITION, HVO_FLOW_VALUE, HVO_PERCENT, HVO_OPEN, HVO_CLOSE, HVO_MAXIMUM, HVO_MINIMUM, HVO_NULL

Percent: **Reserved for future use. Do not change from factory default setting.**

Flow: **Reserved for future use. Do not change from factory default setting.**

Note: Input network variables have higher priority than configuration variables.

Example: the EL diffuser will use the value of nviSetPoint (if this value is valid/non-default) as set point instead of nciSetPnts.

Output Network Variables

Function	Description	Symbol On Screen (SCPTs, SNVTs)	Default value	Range Available
Space Temperature	Reports current space temperature.	nvoSpaceTemp	Current room temp	10 – 49°C (50 – 120°F)
Supply Air Temp	Reports the supply air temperature to the network.	nvoSupplyAirTemp	Current SA temp	10 – 49°C (50 – 120°F)
Unit Status	Reports EL status. Combines the operating mode, capacity of heating and cooling used and any indication of alarms present.	nvoUnitStatus	HVAC_OFF, 0.000, 0.000, 0.000, 0.000, 0	³ See below
Effective Setpoint	Informs the network of the effective setpoint when the setpoint is changed.	nvoEffectSetPt	Current set point	50 – 95°F (10 – 35°C)
Flow	Reports what the EL flow rate is.	nvoBoxFlow	Current flow	See Performance Guide
Current Energy Hold-Off State	Reports the current energy consumption state of the EL. See Energy Hold-Off	nvoEnergyHoldOff	0.0 0 (2 fields separated by a space)	0 to 100%, 0 or 1
Terminal Load	Reports energy use as a function of percentage of maximum flow setting and supply air temperature.	nvoTerminalLoad	0.000	-163.84 % TO 163.84 %

Terminal Command Output	Reports the condition requested by the nviTermCmdIn variable.	nvoTermCmdOut	blank	N/A
-------------------------	---	---------------	-------	-----

³ This variable consists of seven fields: operating mode, heat_output, heat_output_secondary, cool_output, econ_output, fan_output, in_alarm.

Valid range

Operating mode : HVAC_HEAT, HVAC_COOL, HVAC_MRNG_WRMUP, HVAC_NIGHT_PURGE, HVAC_OFF.

Heat_output : 0 – 100 % Max Flow

Heat_output_secondary : Not used

Cool_output : 0 – 100 % Max Flow

Econ_output : Not used

Fan_output : Not used

In_alarm : Refer to Acutherm EL Trouble Shooting Guide

Power Failure

Configuration values are stored in non-volatile memory so that the EL diffusers can resume normal operation when power is restored after failure. Input network variable values will be restored only if updated via network.

Binding Network Variables

1. Drag an 'Input' or 'Output' Network Variable shape from the LonMaker Basic Shapes stencil over to the drawing and place it on top of the Functional Block.
2. The 'Choose a Network Variable' window appears. Choose one or more of the network variables available for the specified functional block and click 'OK.' The network variables selected appear on the functional block.
3. Drag a Connector shape to the drawing and drop it so one end of the connector shape locks onto one of the network variables you want to connect (the point where they connect will be highlighted red). Then drag the unconnected end of the connector shape to the other network variable you want to connect.
4. Repeat steps 1, 2, 3 for other network connections.

Putting The EL In Operating Mode

1. If the network was built off-site and it is time to put the physical EL in operating mode, connect wires to the EL and then from the network drawing right click on the particular EL device shape and choose 'Commission'.
2. A screen appears prompting for a service pin. Press the service pin (sketch, p.10) on the EL to finish the commissioning process. In the project drawing, the device shape should now be green indicating it is addressed and online.

AIR DENSITY COMPENSATION

Installation at altitudes above 1650 ft/ 503 m requires modified settings for air density effects. This can be factory or field installed as follows:

Use the network management tool to set the value of the network variable 'nviTermCmdIn' according to the table below:

Altitudes	nviTermCmdIn
1648 – 3279 ft / 502 – 999 m	"altoffset#1650"
3280 – 4920 ft / 1000 – 1500 m	"altoffset#3500"
4921 – 6561 ft / 1500 – 2000 m	"altoffset#5500"
6562 – 8202 ft / 2000 – 2500 m	"altoffset#7000"
Above 8202 ft / 2500 m	"altoffset#9000"

Example: To operate an EL diffuser at 2000 ft / 610 m, set nviTermCmdIn to "altoffset#1650" (no space between characters).

SYSTEM AIR BALANCING

VAV systems are balanced for design air volume at maximum air flow and systems using Therma-Fuser VAV diffusers are no exception. When all the Therma-Fuser diffusers are set for maximum airflow by fully opening them, the system is really a constant air volume system and is balanced as a constant volume system. Balancing dampers are best located at the takeoff before the runout to the diffuser.

1. Prepare system for balancing. (Make necessary checks for diversity, fan capacities, fan rotation, minimum outside air requirements, duct leaks and static pressure controller design setting. Set outside air control damper for minimum air and return air control damper for maximum air.)

2. Open EL diffusers for balancing.

EL diffusers are opened by using balancing stops (contact factory)

or

by adjusting the value of the network variable 'nviManOverride' to 'HVO_OPEN, 0.000,0'. Allow 10-15 minutes for all diffusers to open fully.

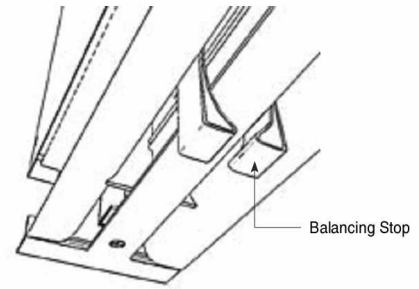

3. Start fans, adjust system for 100% air flow and make system checks. (Measure static pressure across filters and coils and at sensor for static pressure controller. Measure supply, return and branch duct air flow.)
4. Measure air flow from each EF diffuser and adjust the damper at the duct takeoff to obtain maximum design air flow. Air flow measurement may be with a direct reading diffuser balancing hood or air velocity meter. **In either case, measurements are made with all appearance panels in place.** This is because the appearance panel affects pressure drop through the diffuser. When velocity meter is used to measure the discharge velocity, the velocity is measured at the top edge of the housing.
5. When balancing is complete, return each model EF diffuser to normal operation by
 - removing the balancing stop
 - or
 - returning the value of the network variable 'nviManOverride' to 'HVO_OFF, 0.000, 0'.

Note: Diffuser noise is caused by higher velocity air through the diffuser which is caused by a high static pressure. Acutherm recommends a static pressure no higher than .25" wg/ 62 Pa but some system designers may accept higher noise levels and opt for a higher static pressure. Care should be taken not to exceed the design maximum static pressure at the takeoff to the first EF diffuser after the static pressure control or, if none, after the fan.

TROUBLE SHOOTING

Before examining the Therma-Fuser diffuser for failure it is worth the time to be sure the system is functioning properly and that nothing has been overlooked.

The system should be:

1. Delivering 50°–68°F/ 10°–20°C supply air when in the cooling mode.
2. Delivering 80°–120°F/ 26.5°–49°C supply air when in the heating mode.
3. Maintaining static pressure at the inlet to each Therma-Fuser diffuser between .05 and .25"wg/ 12 Pa and 62 Pa.
4. Maintaining continuous fan operation during occupied hours.

Once the above checks have been completed examine and record the following:

1. Conditions outside the EL
 - A. Room temperature 4 ft/1200 mm above the floor directly under the Therma-Fuser diffuser.
 - B. Supply air temperature at the Therma-Fuser diffuser. (Temperature may vary over time. Several measurements at different times may be required.)
 - C. Static pressure at the inlet of the Therma-Fuser diffuser.
2. EL General
 - A. Determine the current setpoint.
 - Use a computer on the network with software for LonMaker or other network management tool to select or highlight the specific EL unit.
 - Browse the network variables to locate the variable "nvoEffectSetPt". The value of this variable is the current setpoint for the EL unit.
 - Check that other network variables are not overriding the current setpoint or limiting flow. Following are network variables that can override and the normal operation for each.
nviEmergCmd = "EMERG_NORMAL" or "EMERG_NUL."

nviManOverride = "HVO_OFF,0.000,0."

nviEnergyHoldOff = "0.00 0."

If they are other than as shown above, temporarily set the variables for normal operating condition before further checking the EL unit.

B. Damper blade position estimated visibly from views shown below:

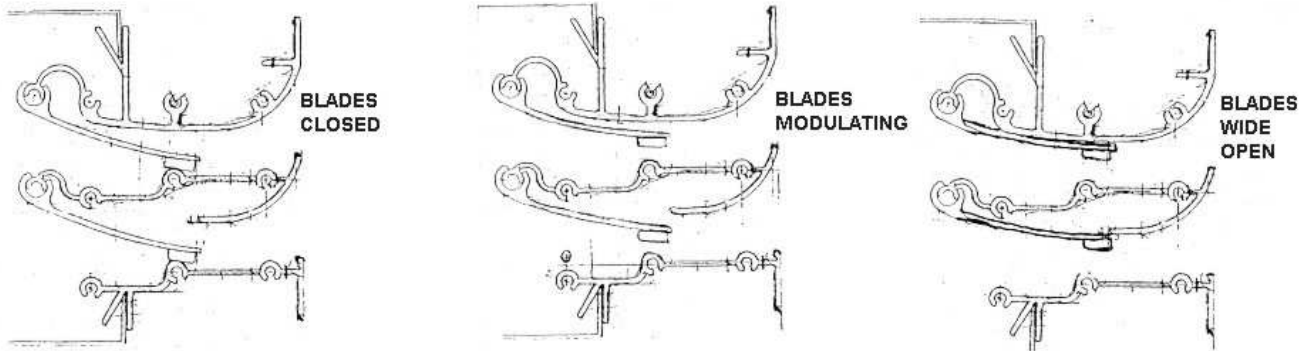

C. Use the information from steps 1 and 2 on the previous page to determine if the damper blades are correct for the conditions.

- Determine mode. The EL unit should be in cooling if the supply air temperature (1.B. previous page) is below the set point (2.A. previous page). It is heating if the supply air temperature is above both the room temperature and the set point.
- For room temperatures (1.A. previous page) more than 2°F/1.2°C from set point (2.A. previous page), damper blades should be as shown in the table below.

Notes:

Room temperature more than ±2°F/1.2°C from set point has been selected as a general rule of thumb for trouble shooting to avoid more complicated control algorithms within that band. Control is intended to be tighter but will depend on system conditions.

If any of the set points are changed to achieve full open or full closed conditions, wait 5 to 10 minutes to make sure the room and system have stabilized.

For room temperatures less than 2°F/1.2°C from setpoint, the damper blades may be somewhere between open and closed.

MODE	ROOM TEMP minus SET POINT	DAMPER BLADE POSITION (sec 2.B.)	VOLTAGE TO THE HEATER (sec 2.E.)
Cooling	+2 F/1.2 C	Open	> 25VDC
	- 2 F/1.2 C	Closed	< 1VDC
Heating	+2 F/1.2 C	Closed	< 1VDC
	- 2 F/1.2 C	Open	> 25VDC

D. If the damper blades are not according to the table, check for any overrides limiting opening or closing? See step 2.A. on the previous page.

E. If there are no limiting flow stops or overrides, measure the voltage supplied to the heater. Remove the controller cover and measure the voltage across the terminals marked heat. See sketch of controller. If the voltage is not according to the above table, complete step 3 "EL Electrical" before contacting Acutherm.

TO REMOVE CONTROLLER COVER

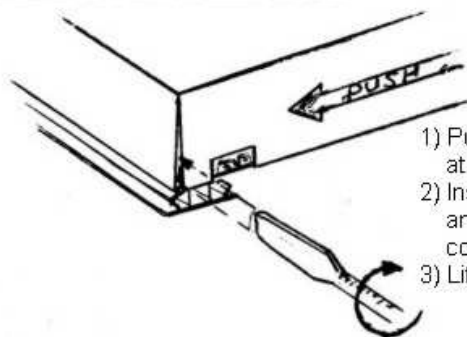

- 1) Push controller cover sideway and at the same time,
- 2) Insert flat screwdriver in slot at corner and twist to push out tab at bottom of cover end.
- 3) Lift cover.

3. EL Electrical

A. LED indicators on EL board.

- Yellow off / Green on – unit operating OK. See D. Both LED's off – no power. Supply voltage should be 22-26 VAC. Measure voltage between terminal screws.
- If not 22-26 VAC, check source and make sure wire are making contact with the terminals.
- Yellow on / Green off – no program. Contact Acutherm.
- Yellow blinking / Green off – needs to be commissioned using network management tools.
- Yellow off / Green blinking (long: 1 sec, short: .5 sec)
 - 1 long 1 short = Faulty room temp. sensor / wiring connection. See C. below.
 - 1 long 2 short = Faulty supply air temp. sensor / wiring connection. See C. below.
 - 1 long 3 short = Out-of-range reference voltage. Must be cleared by resetting. See D.
 - 1 long 4 short = Faulty flow sensor / wiring connection. See C. below.
- Both LED's on – contact Acutherm.

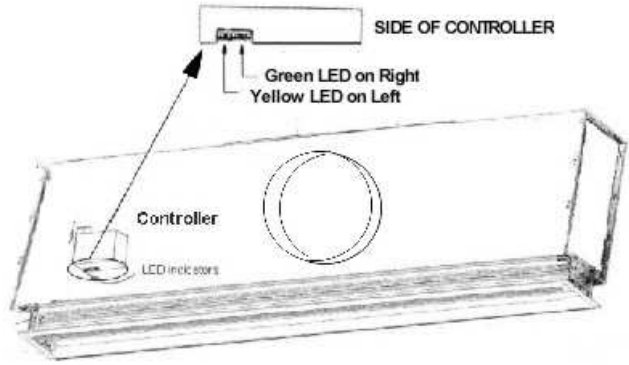

B. Network Information

- Use a computer on the network with software for LonMaker or other network management tool to select or highlight the specific EL unit.
- Browse the network variables to locate "nvoUnitStatus."
- Go to the end of the fields and look at the last number set which is "ALARM". The alarm codes are:
 - 1= Faulty room temp. sensor / wiring connection. See C. below.
 - 2= Faulty supply air temp. sensor / wiring connection. See C. below.
 - 4= Faulty flow sensors / wiring connection. See C. below.
 - 8= Out-of-range reference voltage. Must be cleared by resetting. See D.

Combinations of codes are:

3=1+2	7=1+2+4	11=1+2+8	15=1+2+4+8
5=1+4	9=1+8	12=4+8	
6=2+4	10=2+8	13=1+4+8	

- C. Where faulty sensor / wiring connections are indicated, remove the controller cover. Then remove the wires to each sensor (room temp, duct temp and flow 1) from the terminal and measure the resistance between each wire and the terminal marked common. If the resistance is between 360 and 2000, reinstall the wire making sure that it makes contact with the terminal. If the resistance is outside the range, check the common terminal connections. If all common wires are in contact with the terminals and the resistance is still outside the range, contact Acutherm.

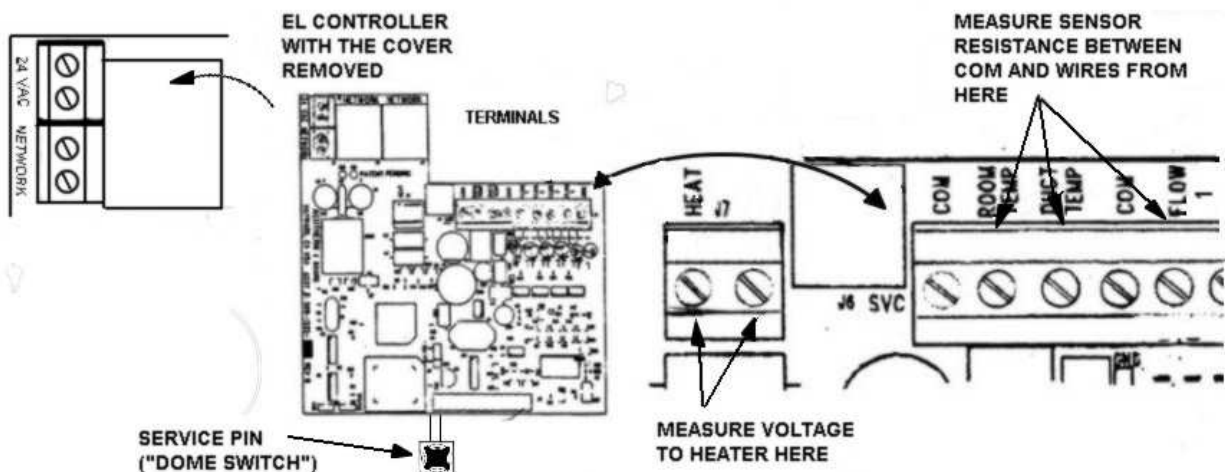

- D. Resetting may clear a communication problem and is necessary for an out-of-range reference voltage fault. Methods for resetting are:
- Power off and then on. This can be done by removing one of the 24 volt power wires from the terminal and then reconnecting it. Be careful not to touch anything else with the bare wire as it's live.
 - Send a reset command from a computer on the network with software for LonMaker or other network management tool. An error message means resetting was unsuccessful. If so, try resetting by power off and then on. Wait 2 to 3 minutes after resetting before rechecking the condition of the EL unit. If it still has a communication problem or signals an out-of-range reference voltage, contact Acutherm.

MAINTENANCE

The moving parts of the EL diffuser have no maintenance or lubrication requirements. We are often asked to recommend periodic maintenance procedures and a spare parts stock. Recommended maintenance is to clean the outer surfaces of the Therma-Fuser diffuser—nothing else. We do not recommend stocking any spare parts. Our customers also confirm that stocking is unnecessary.

CONTROLLING THE SYSTEM

References:

- System Design, p4.
- Chapters 2.2, 3.1 and 3.2, pp 6, 7 and 8, Designing Modular VAV Systems, Form 5.2
- Air Handling and Fan Coil Units Subzoned with Therma-Fuser VAV Modules, Form 6.7
- DX Equipment Zoned with Therma-Fuser VAV Modules, Form 6.5

Supply Air Temperature

The sources of cooling and heating are controlled from supply air temperature. As with all VAV systems the goals are to achieve a constant supply air temperature (may be reset to another **constant** supply air temperature) and to limit the supply air temperature. Limits for supply air temperature should be between 50°F/10°C and 68°F/20°C when cooling and between 80°F/26.5°C and 120°F/49°C when heating. The heating temperature limit should be as low as possible. These objectives are best achieved by modulating chilled water valves, hot water valves and other variable equipment from supply air temperature. On/off equipment such as DX compressors and electric heat are cycled from supply air temperature. Use a discharge air sensor for the supply air temperature signal.

Mode change between heating, recirculation and cooling is controlled from room temperature. Signals from the EL Therma-Fuser may be used for mode change. A “majority rules” approach is recommended.

See the flow charts on the next page for an example control sequence.

Static Pressure

As with all VAV systems, the fan must run continuously during occupied times. Goals of static pressure control are to provide enough static pressure to obtain the required air volume especially at the diffuser farthest from the fan, to limit static pressure at both full flow and turndown to avoid diffuser noise and to provide pressure independence or consistent operation as the system flow changes.

These objectives can be achieved with the usual methods of automatic static pressure control: bypass dampers, discharge dampers, zone dampers, and fan control (variable speed drives, inlet dampers, etc.). Locate the static pressure sensor as far down the duct as possible—at least 2/3 down the duct from the first takeoff.

Flow Chart For AHU Controller (Main Page)

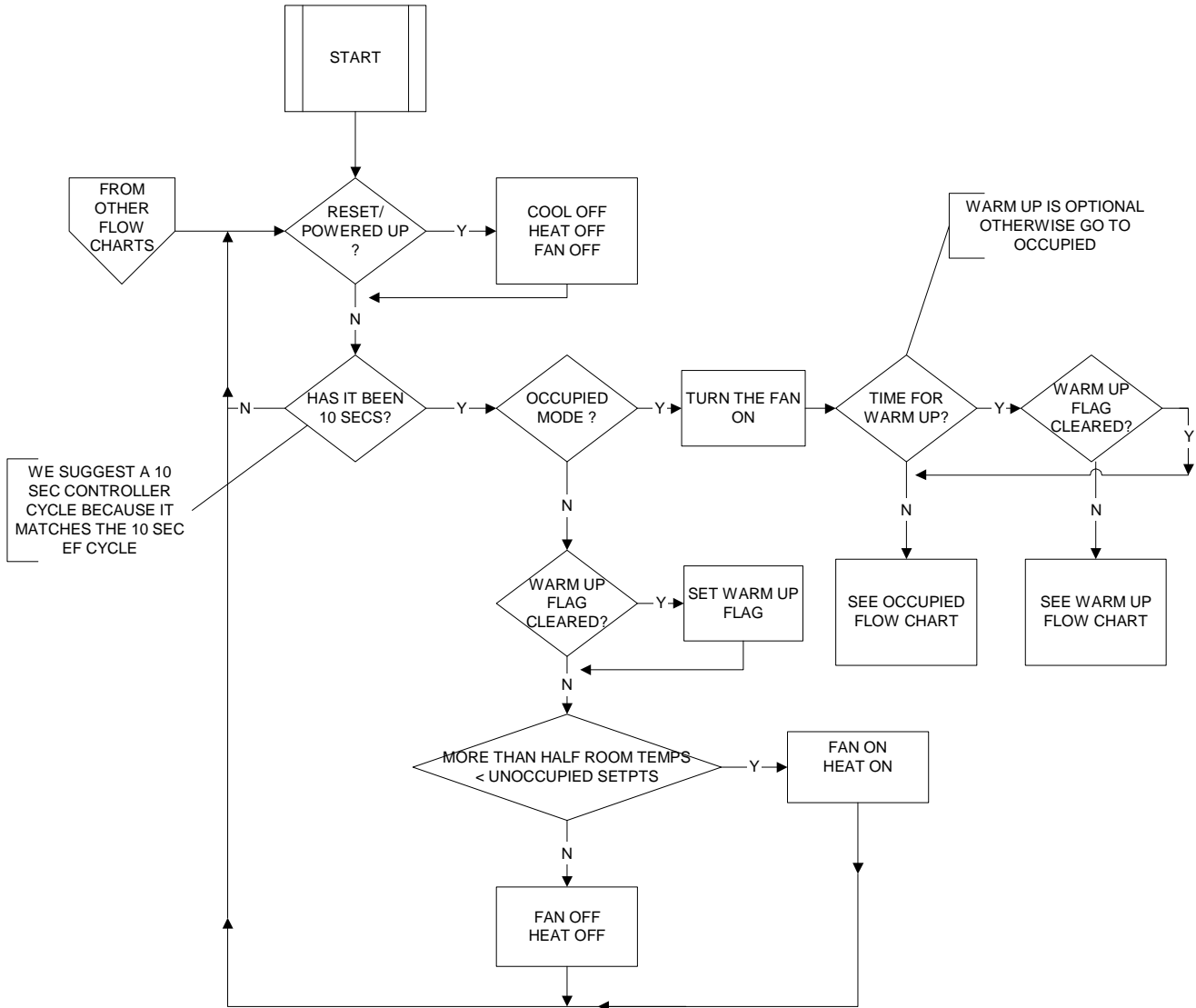

Flow Chart For AHU Controller (Occupied Mode)

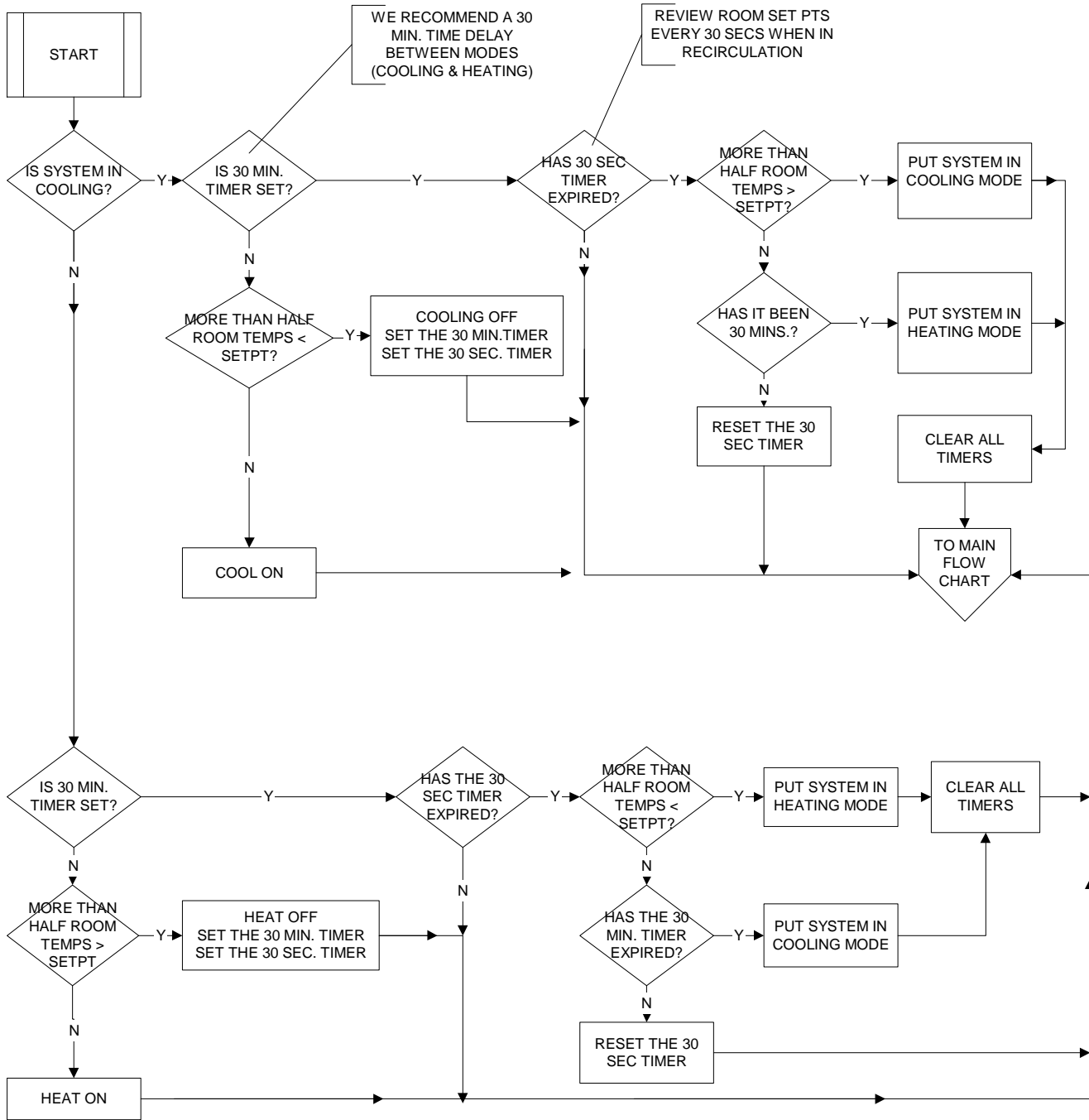

Flow Chart For AHU Controller (Warm Up)

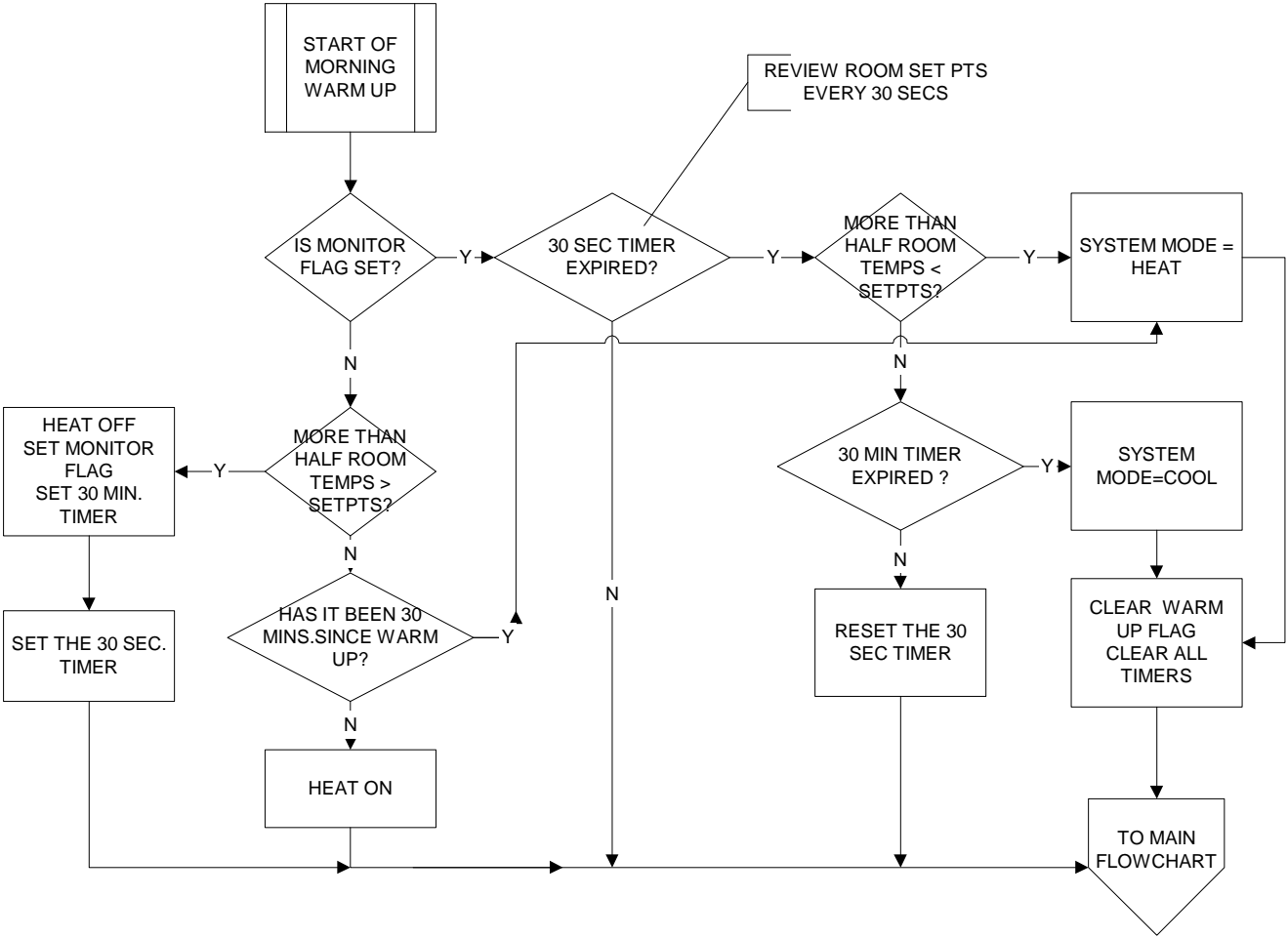

MEASURING ENERGY CONSUMPTION

Supply air temperature, room temperature and flow from the EL can be logged and used to calculate the energy used by each diffuser in BTU/HR or watts. This function will have to be written into either a computer connected to the network or another device capable of this type of computation. The formula's are:

BTU/HR = difference in °F between supply and room temps X flow in cfm X 1.10

Watts = difference in °C between supply and room temps X flow in l/s X 1.23

TWO YEAR WARRANTY

Acutherm warrants that its EL Therma-Fuser diffusers, exclusive of any options and accessories (whether factory or field installed) shall be free from defects in material or workmanship for a period of two (2) years from the date of shipment and agrees to repair or replace, at its option, any parts that fail during said two (2) year period due to any such defects which would not have occurred had reasonable care been taken, provided that such parts have been inspected by Acutherm and found defective and provided the diffusers have been given normal and proper usage and all parts and controls remain unaltered. Acutherm makes NO WARRANTY OF MERCHANTABILITY OF PRODUCTS OR OF THEIR FITNESS FOR ANY PURPOSE OR ANY OTHER EXPRESS OR IMPLIED WARRANTY WHICH EXTENDS BEYOND THE LIMITED WARRANTY ABOVE. ACUTHERM'S LIABILITY FOR ANY AND ALL LOSSES AND DAMAGES RESULTING FROM DEFECTS SHALL IN NO EVENT EXCEED THE COST OF REPAIR OR REPLACEMENT OF PARTS FOUND DEFECTIVE UPON EXAMINATION BY ACUTHERM. IN NO EVENT SHALL ACUTHERM BE LIABLE FOR INCIDENTAL, INDIRECT OR CONSEQUENTIAL DAMAGES OR DAMAGES FOR INJURY TO PERSONS OR PROPERTY. Acutherm shall not be responsible for freight to or from its plant in connection with the inspection, repair or replacement of parts under the terms of this limited warranty nor for cost of removal or installation.



**The Individual
Temperature Control People**
1766 Sabre Street
Hayward, CA 94545
Tel: (510) 785-0510
Fax: (510) 785-2517
<http://www.acutherm.com>
e-mail: info@acutherm.com

Subject to change without notice.
FORM 54.2 REV 0703 • Supersedes FORM 54.2 REV 0608