

## PART 1 - GENERAL

### 1.01 DESCRIPTION

- A. General
1. Furnish 50/50 Hydraulic System complete from one manufacturer. Provide all labor, materials, tools and equipment to furnish the 50/50 System complete as herein specified.

### 1.02 RELATED WORK BY OTHERS

- A. Preparation of opening including jambs and header will be by General Contractor. Any deviation of site conditions contrary to approved shop drawings must be called to the attention of the architect.
- B. All header, blocking, support structures and jambs as required.
- C. Paint or otherwise finishing all trim and other materials adjoining door.
- D. Provide hydraulic fluid in quantity necessary for proper system operation.

### 1.03 SUBMITALS

- A. Product Data
1. Submit manufacturer's product data and roughing-in diagrams.
  2. Complete shop drawings are to be provided prior to fabrication indicating construction and installation details.

### 1.04 QUALITY ASSURANCE

- A. Provide each 50/50 System as a complete unit by one manufacturer, including frames, panels, brackets, guides, hardware, operators and installation accessories to suit opening(s).
- B. Wind Loading: Design and reinforce 50/50 system to withstand a wind loading pressure to comply with state and federal code requirements.
- C. Preparation of the opening shall conform to the criteria set forth by UBC, 2000 International Building Code & 1999 Standard Building Code (ASCE 7-98).

### 1.05 PRODUCT DELIVERY, STORAGE AND HANDLING

- A. Proper storage of the 50/50 system before installation and continued protection during and after installation will be the responsibility of the general contractor.

### 1.06 WARRANTY

- A. Frame/Panel, hydraulic cylinders and controls shall be guaranteed for one year against defects in material and workmanship from date of shipment to the job site.
- B. Optional factory-supplied, manufacturers standard, aluminum, inside-sash retainer assembly and 7/8" IG or 1/4" glass shall be guaranteed for one year against defects in material and workmanship from date of shipment to the job site.
- C. Retainer assembly, glass or other cladding/covering by others is not included in this warranty.

## PART 2 - PRODUCTS

### 2.01 ACCEPTABLE MANUFACTURERS

- A. Subject to compliance with requirements, manufacturers offering products which may be incorporated into the work, include, but are not limited to, the following:

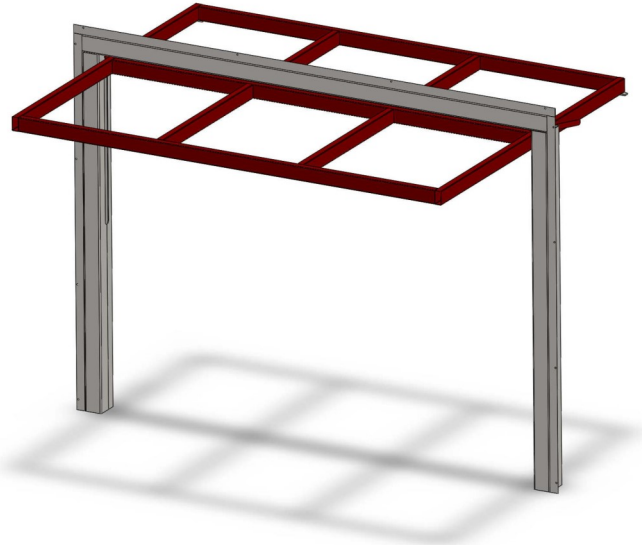

**Crown Incorporated**  
135 McLeod Avenue South  
Plato, MN. 55370  
(320) 238-2616  
www.crowndoors.com  
info@crowndoors.com

- B. Upon compliance with all of the criteria specified in this section, manufacturers wishing to bid products similar to the product specified must submit to the architect - 10 days prior to bidding - complete data in support of compliance. The submitting manufacturer guarantees the proposed substituted product complies with the product specified and as detailed on the drawings.

### 2.02 MATERIALS

- A. Product to be the 50/50 Hydraulic System as furnished by Crown Incorporated
1. Construct panel/frame with structural steel tube (of ASTM-A500 grade minimum) framing to comply with applied wind code.
    - a. Optional: 304 stainless steel tube framing for highly corrosive environments.
  2. Frames shall be constructed of structural steel tubing and other structural steel shapes, and designed to the same loading requirements for live, dead and wind loads as the surrounding construction, with a maximum CTC from vertical and horizontal members of 60".
  3. Panel frame shall be designed so that no center "cane bolt" is required in the floor.

4. Panel frame shall not exceed 6" [153] thickness.
  5. Panel frame shall be factory-welded at all joints and connections, with smooth welds not to exceed 1/4" [6] thickness.
  6. Panel frame shall be primed with rust-resistant red oxide to provide corrosion resistance, and be prepared for field finishing, if required.
  7. Factory-Supplied neoprene seals/weather stripping will be shipped loose for field-install to protect against damage during transport.
- B. 50/50 System shall be operated by hydraulic cylinders that are mechanically fastened to the panel frame.
1. Cylinders will be designed to carry the required loads during operation, open position and closed position. Internal stops will be installed as not to allow over-extension of the cylinders, therefore not allowing the system to open or close beyond its limit.
  2. System speed shall be no less than 20' [6096] per minute.
- C. Power Operator - All electrical controls meet National Electrical Code Section 513. Standard voltage is 220V single phase.
1. Hydraulic power unit; 220v, single phase, "up-down" push button or key switch stations for separate mounting.
  2. Power unit to power (2) hydraulic cylinders which open and close the door/window. Power unit to be pre-wired, factory-tested and provided with supply cables for final hook-up (by others).
  3. "Open-Close" control units will be wired for constant-hold operation.
  4. Single phase (220V) or three phase (220/460V) electrical source to hydraulic power unit to be supplied by others (manufacturer's standard).
  5. Each door operator shall have thermal overload protection for the motor.
- D. Other Requirements:
1. Cladding hardware to be provided by others.
  2. Interior (if required) and exterior panel covering shall be specified; Furnished by 50/50 System manufacturer is optional.
- E. Finishes
1. Entire system frame and panel shall be cleaned and primed with rust-resistant red-oxide primer, prepared for field finish (by others).
    - a. Optional Finishes
      - i. Manufacturers' standard RAL powder-coated
- F. Available Accessories/Options
1. Photo eyes or lead-edge sensor that stops (or stops and reverses) the downward movement of the door/window.
  2. Warning horn/Strobe light assembly
  3. Remote receiver w/transmitter
    - a. Additional transmitters available
  4. 24v DC battery back-up system
  5. 3-Phase option
  6. External, weather-resistant, "open-close" control wired for constant-hold
  7. Framing for 36" x 80" man-door (only available with R.O. heights 8' [2438] or higher).
  8. Custom-designed and fitted, aluminum, inside-sash retainer system and custom-sized glazing.
    - a. Optional Glazing Types:
      - 7/8" [22] thick, tempered IG units
      - 3/16" [5] thick, tempered, laminated lites
- 2.03 OPERATION
- A. The 50/50 System shall be opened/closed in the rough opening using a constant-hold push-button or key switch, operating hydraulic cylinders mounted within the door/window frame.
- PART 3 - EXECUTION**
- 3.01 SAFETY
- A. Hydraulic power unit to have a manual emergency let-down valve for closing the system in case of a power outage.
- B. Photo eyes or lead-edge sensor optional.
- 3.02 INSTALLATION
- A. Installation of the 50/50 System shall be by a contractor familiar with this type of installation, and be in strict accordance with the approved build drawings and manufacturers standard printed specifications, instructions and recommendations. All moving parts will be left in good operating condition.
- B. Permanent or temporary electric wiring shall be brought to the power unit location before installation. After the 50/50 System is installed, the general contractor assumes the responsibility of any damage to the system or system components during construction until the building is turned over to the owner.
- C. Fill reservoir with hydraulic fluid (provided by others). Use ATF for cold weather applications or #32 hydraulic fluid for all other applications.
- 3.03 CLEANING
- A. All surfaces shall be wiped clean and free of handprints, grease and soil.
- 3.04 TRAINING
- A. Installer shall demonstrate proper operation and maintenance procedures to owner's representative.
- B. Operating keys and owner's manual shall be provided to owner's representative.

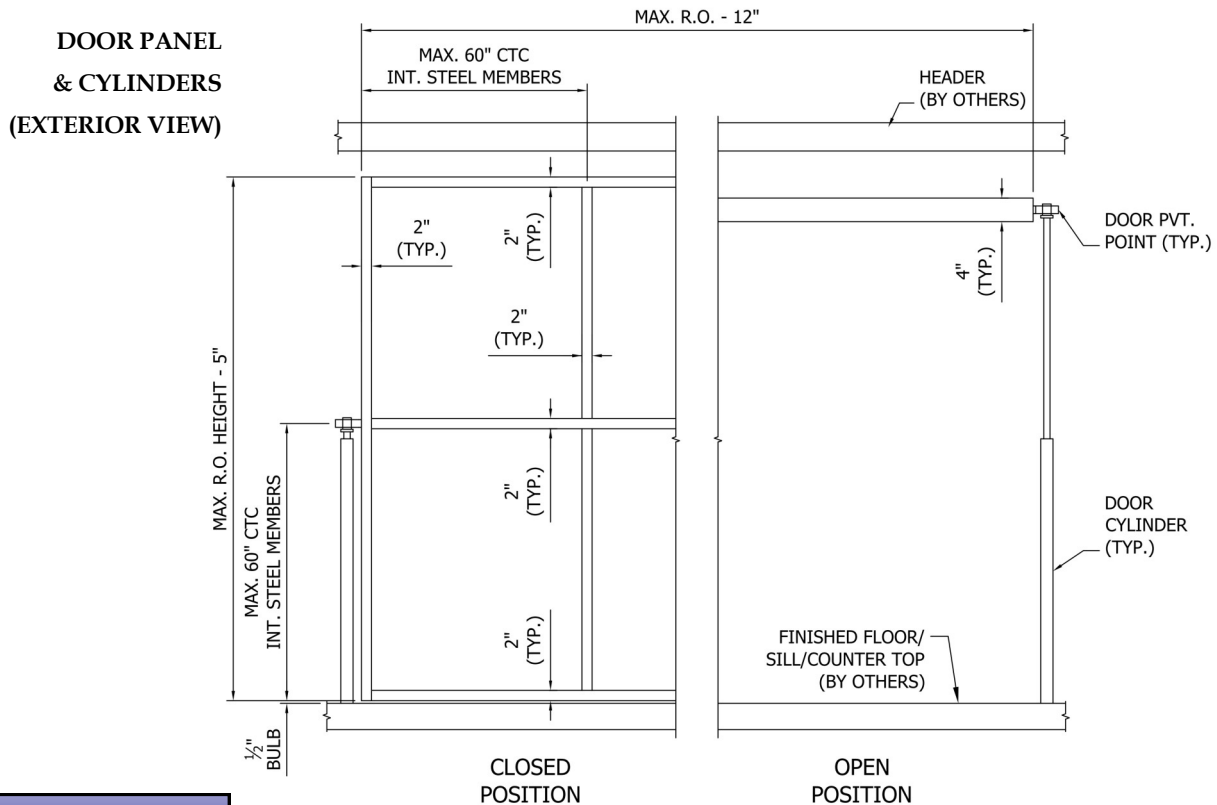
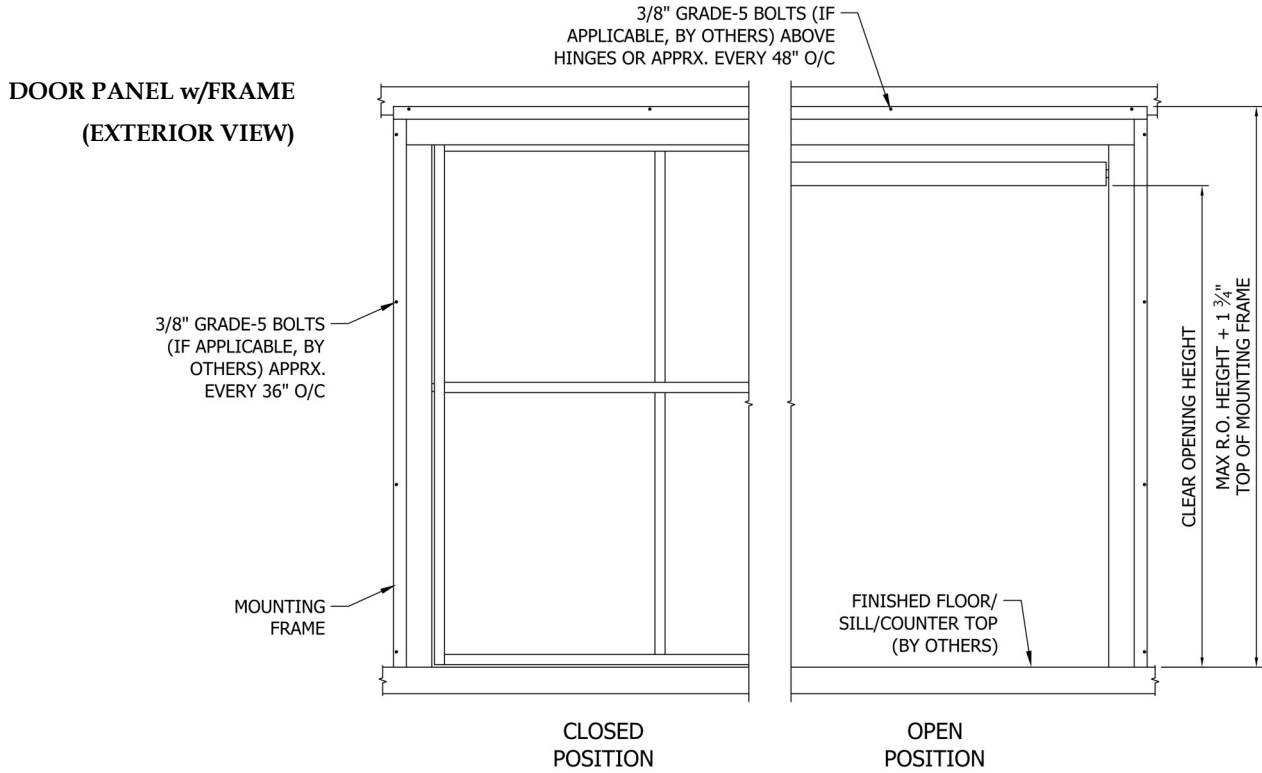

**ELEVATIONS**

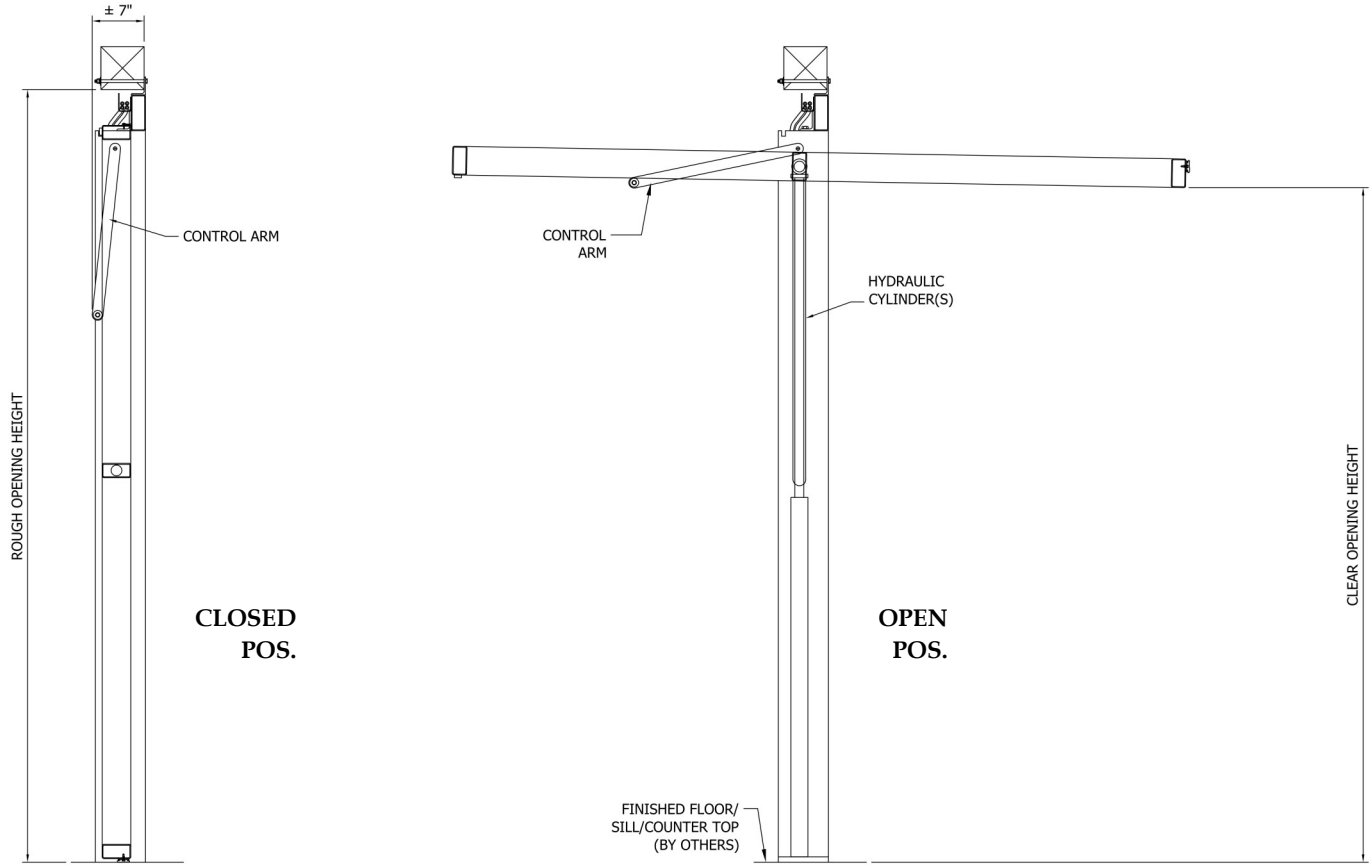

## VERTICAL SECTION VIEWS

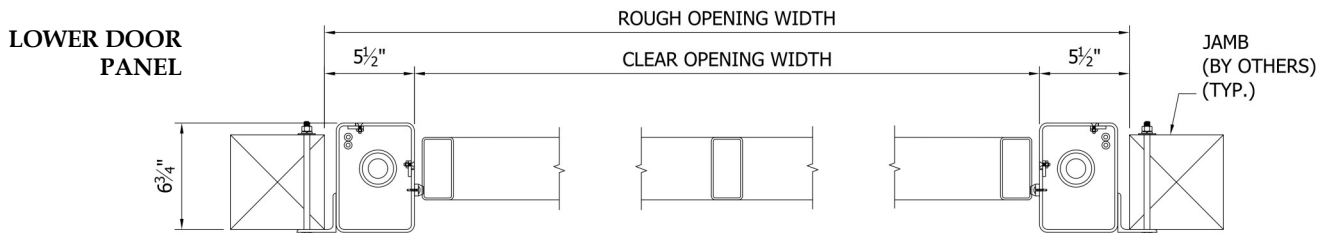
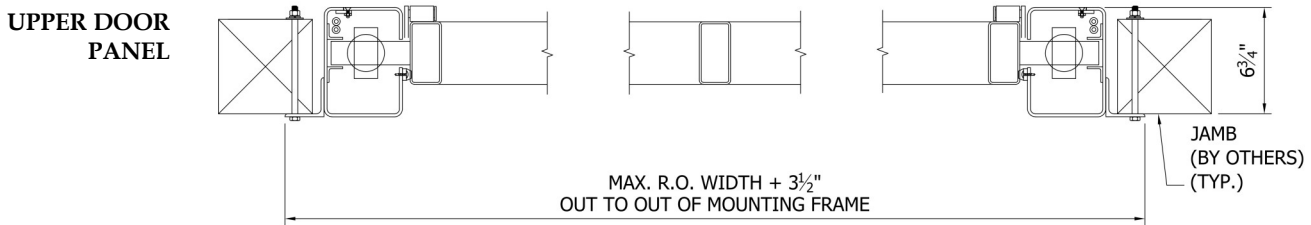

## HORIZONTAL SECTION VIEWS

**SECTION VIEW  
@ HEAD**

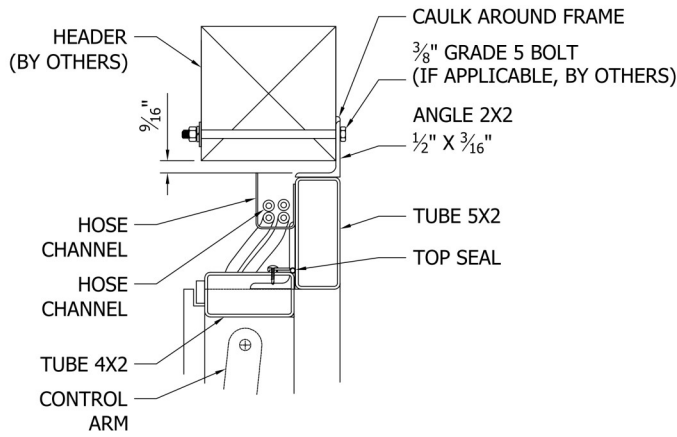

**SECTION VIEW  
@ JAMB**

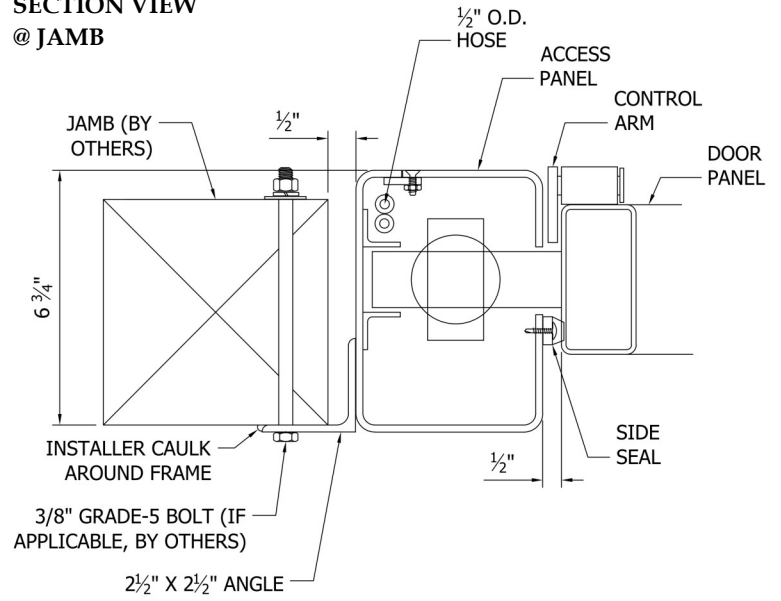

**ATTACHMENT DETAILS**

**SECTION VIEW  
@ MID HORIZONTAL**

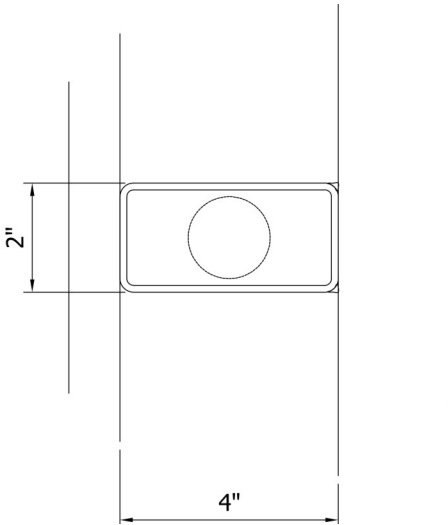

**SECTION VIEW  
@ BOTTOM HORIZONTAL**

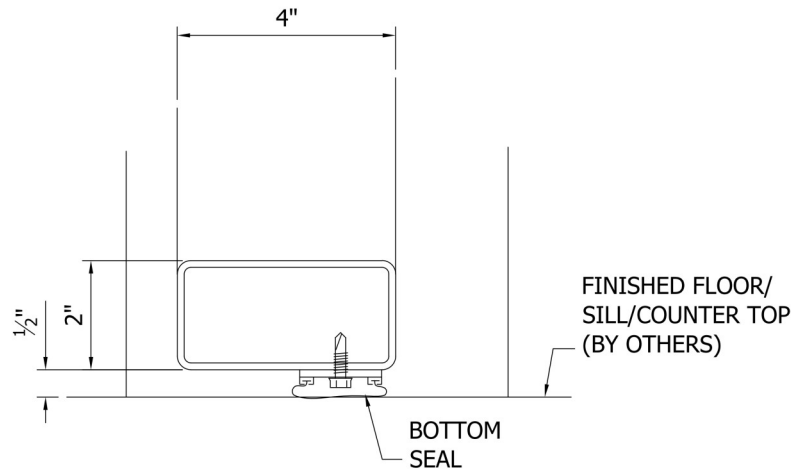

**FRAME DETAILS**

For more information, please contact us at [info@crowndoors.com](mailto:info@crowndoors.com) or visit our website: