

D Systems Residential Fire Pump
13D Compliant Pump Submittal Data Sheet-
3A1HP Dcono Package

Model F-3A12-D

Pump Data

- 3A1 HP 6-1/8 Imp, 1 Stage Centrifugal Pump
- 316L SS Corrosion Resistance Construction
- Built-In Overload , Auto-Reset Provided
- 15.5amp 230V Single Phase UL Motor
- *110V not available
- 1-1/2 F IPT Suction

Pump Flow

(not for certification use)

GPM	0	30	40	45	50	55
PSI	59	55	53	51	50	49

Component

- A - Flow Switch
- B - 1-1/2 Galvanized Riser F NPT
- C - Supervised Control Valve
- D - Pressure Gauge
- E - D Panel Control Box with Full Steel Frame
- F - 40 60 Pressure Switch
- G - Bypass Line w/ 3/4 Backflow Preventer
- H - 3A1 HP Pump
- *Wiring in Liquid Tight Conduit (not shown)

Check Box for Optional Equipment

- I - Butterball Tamper Switch

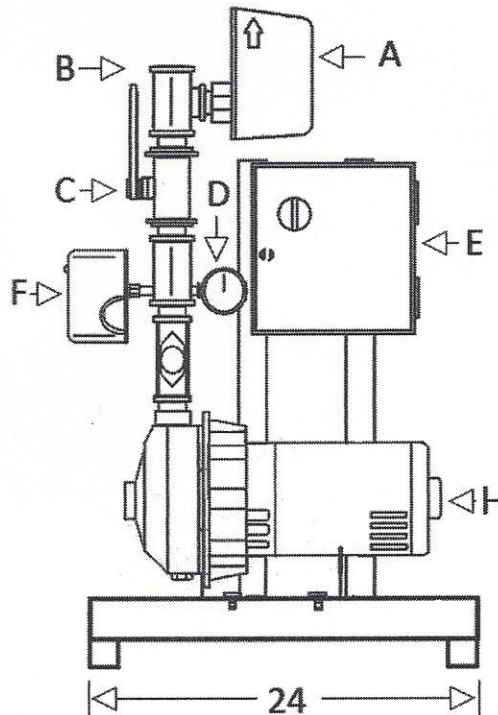
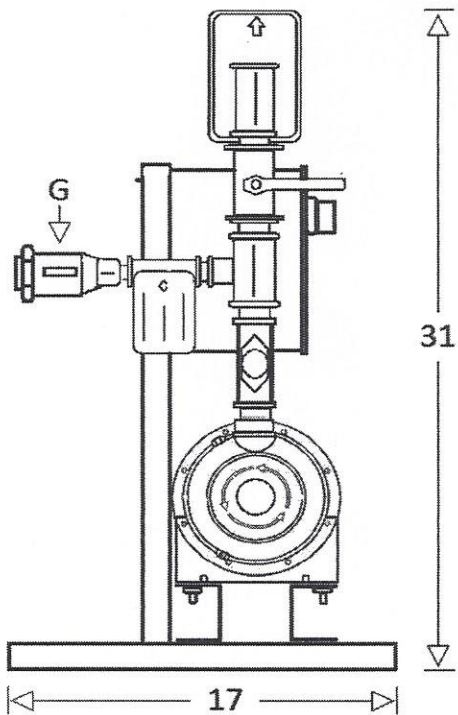

*Note: all measurement in inches