

# ES8622 and ES8544 Assembly Instructions

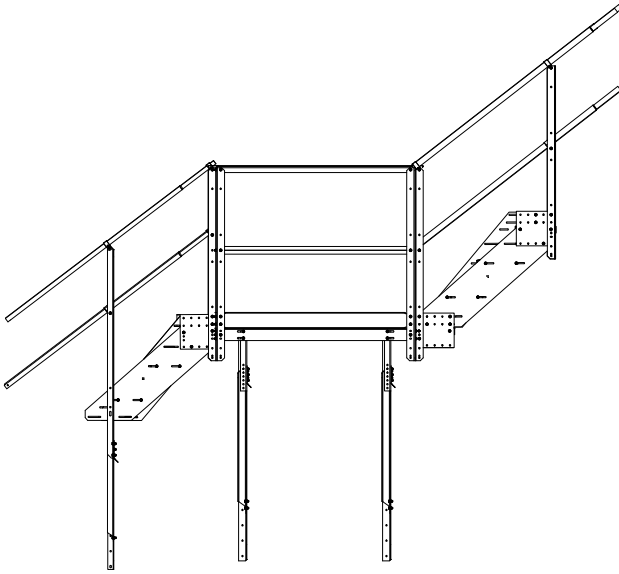

Greene Galvanized Stairs

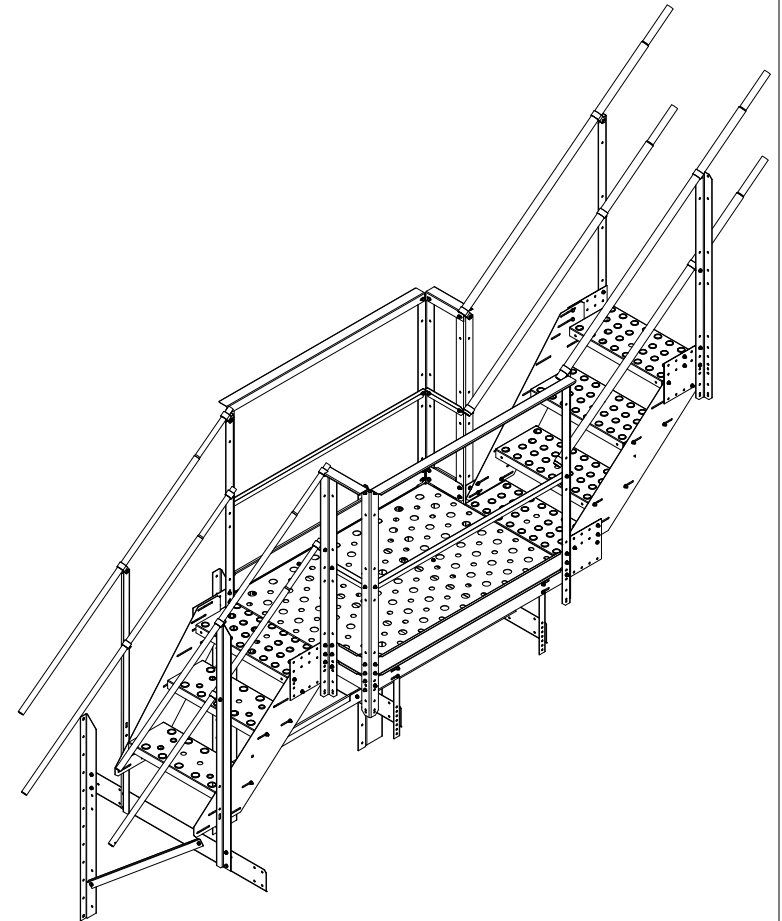
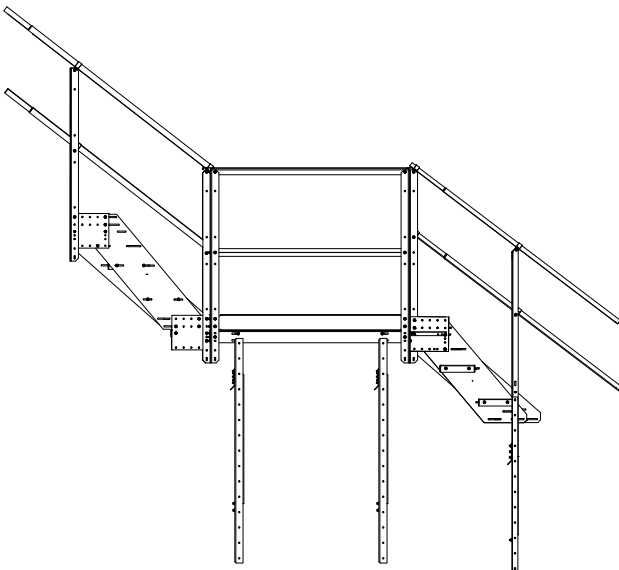

# Parts List

ES-0006

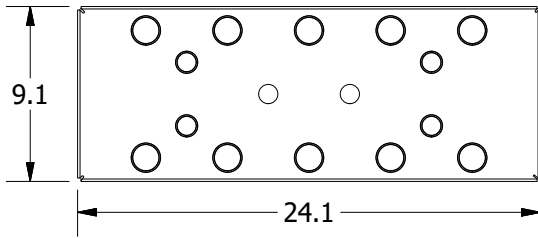

ART-0006

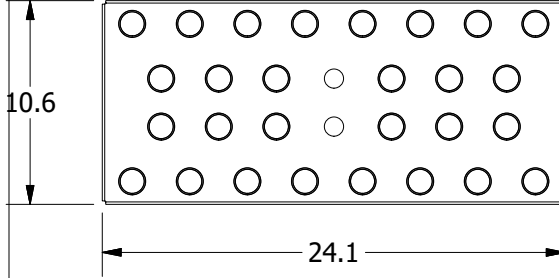

ES-8602

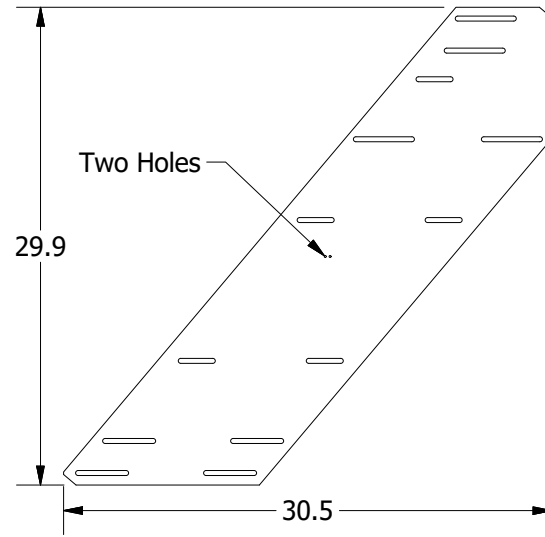

ES-8603

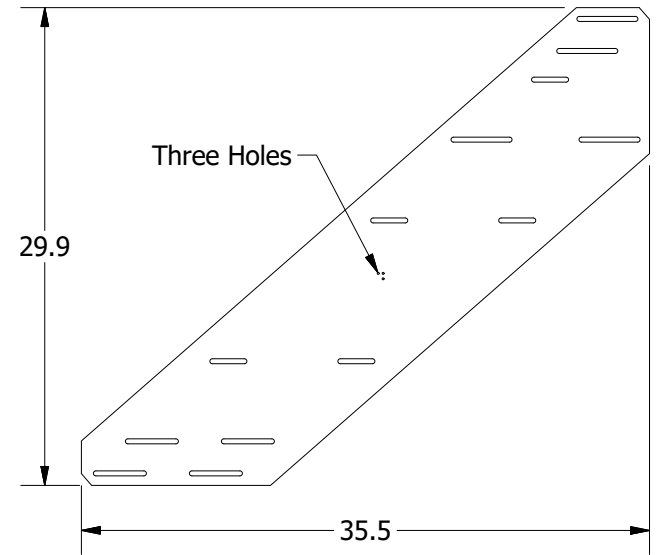

ES-8601

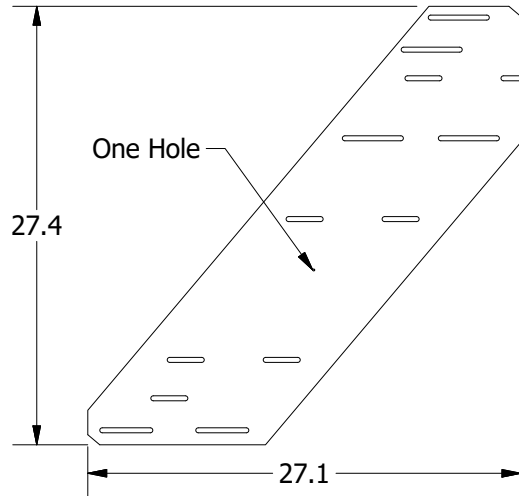

ES-8604

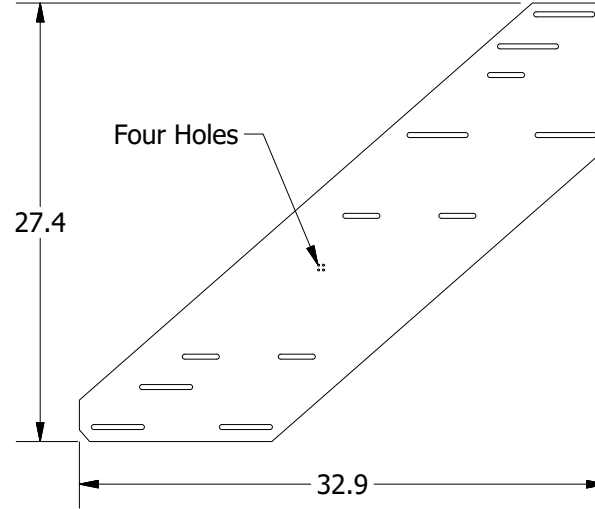

ES-8501

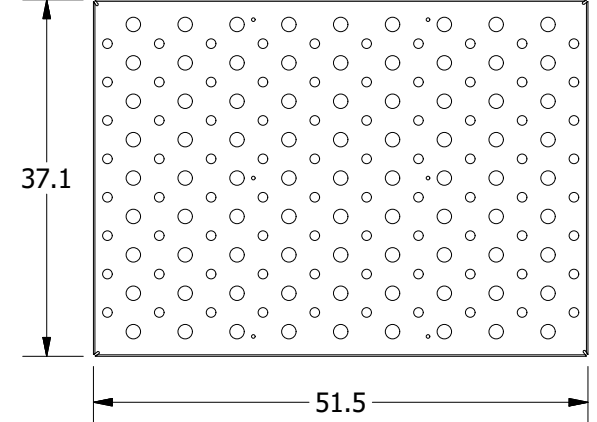

ES-8002

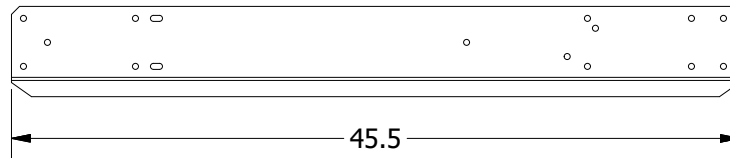

DRAWN Marcus	2/9/2018	Greene Galvanized Stairs East Lynn, IL 217.375.4244 www.greenebinstairs.com	
CHECKED		TITLE	
QA			
MFG			
APPROVED			
		SIZE A	DWG NO ES8622_Assembly_Instructions
		SCALE 1/10	REV
			SHEET 2 OF 15

# Parts List (Continued)

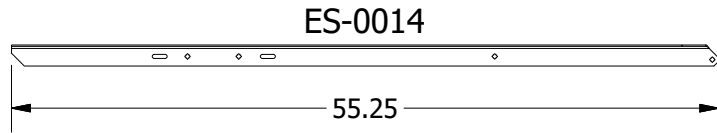

ES-8514

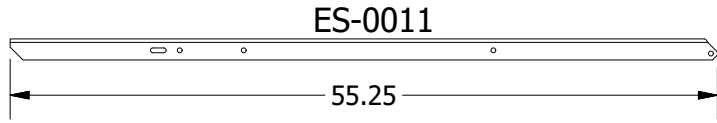
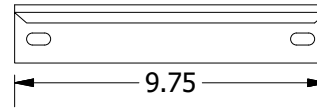

5/16-18x3/4FB

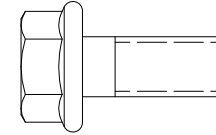

5/16-18SFN

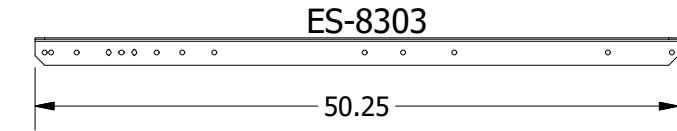
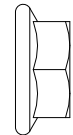

ES-8515

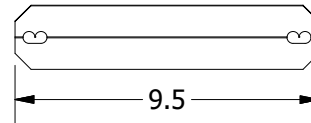

HRC1500

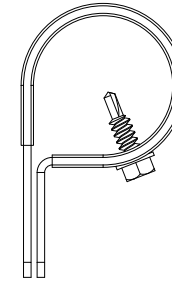

HRC1000

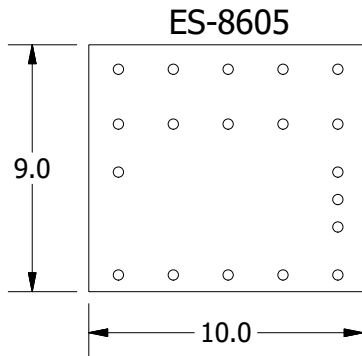
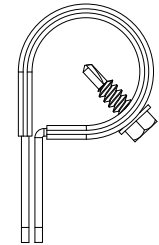

ES-0021

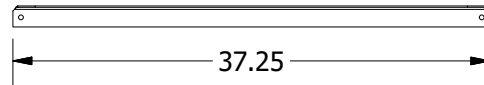

ES-8011

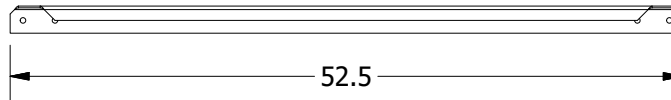

ES-8504

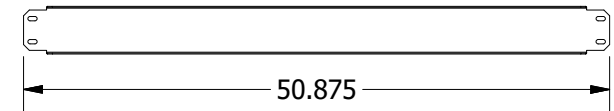

ES-8544

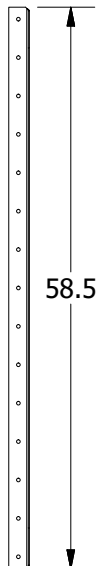

ES-0001

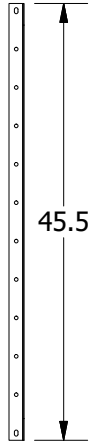

ES-8001

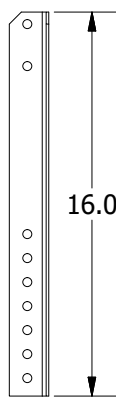

ES-4406

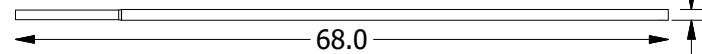

TR1506808

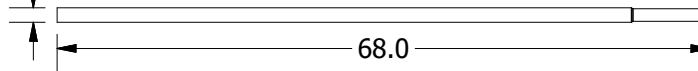

ES-8506

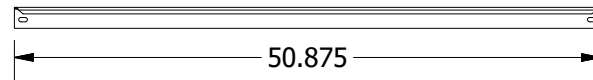

ES-8508

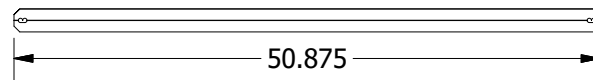

ES-8516

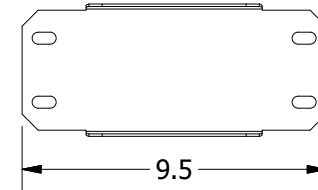

DRAWN Marcus	2/9/2018	Greene Galvanized Stairs East Lynn, IL 217.375.4244 www.greenebinstairs.com	
CHECKED		TITLE	
QA		MFG	
MFG		APPROVED	
APPROVED		SIZE A	DWG NO ES8622_Assembly_Instructions
		SCALE 1/15	REV 3 OF 15

PARTS LIST			
ITEM	QTY	PART NUMBER	DESCRIPTION
1	1	ES-0001	Easy Step Wall Base
2	1	ES-8002	Bracket Extended Stair Wall Cross
3	1	ES-0014	Inside Handrail Post
4	1	ES-0021	Easy Step Knee Brace
5	1	ES-0011	Easy Step Stair Post
6	160	5/16-18x3/4FB	5/16"-18 x 13/4" Flange Bolt
7	160	5/16-18SFN	5/16"-18 Whiz Lock Nut
8	1	ES-8601	Plate Siderail Inside Lower
9	1	ES-8604	Plate Siderail Inside Upper
10	2	ES-0006	Easy Step Stair Step
11	5	ART-0006	A-Series Stair Step
12	6	ES-8605	Plate Siderail Extension
13	2	ES-8002	Eave Wall Cross
14	2	ES-8544	44" Wall Brace
15	2	ES-8011	Knee Brace
16	4	ES-8001	Eave Platform Mount Post
17	1	ES-8501	Platform Deck Skin
18	2	ES-8008	Platform Mid Brace
19	10	ES-8303	Eave Platform Post
20	2	ES-8516	Plat Entry Kickboard
21	2	ES-8504	Platform Side Kickboard
22	2	ES-8514	Plat Entry Handrail
23	2	ES-8515	Plat Entry Int Rail
24	2	ES-8506	Platform Long Handrail
25	2	ES-8508	Platform Side Intermediate Rail
26	1	ES-8602	Plate Siderail Inside Upper
27	1	ES-8603	Plate Siderail Outside Upper
28	4	ES-4406	Easy Step 44 Handrail
29	4	TR1506808	Upper Run Handrail
30	8	HRC1500	1.5" Handrail Clamp
31	8	HRC1000	1.0" Handrail Clamp
32	16	Floorscrews	Self-tapping Handrail Clamp Screws

DRAWN Marcus	2/9/2018	Greene Galvanized Stairs East Lynn, IL 217.375.4244 www.greenebinstairs.com		
CHECKED		TITLE		
QA				
MFG				
APPROVED				
		SIZE A	DWG NO ES8622_Assembly_Instructions	REV
		SCALE	SHEET 4 OF 15	

# STEP 1

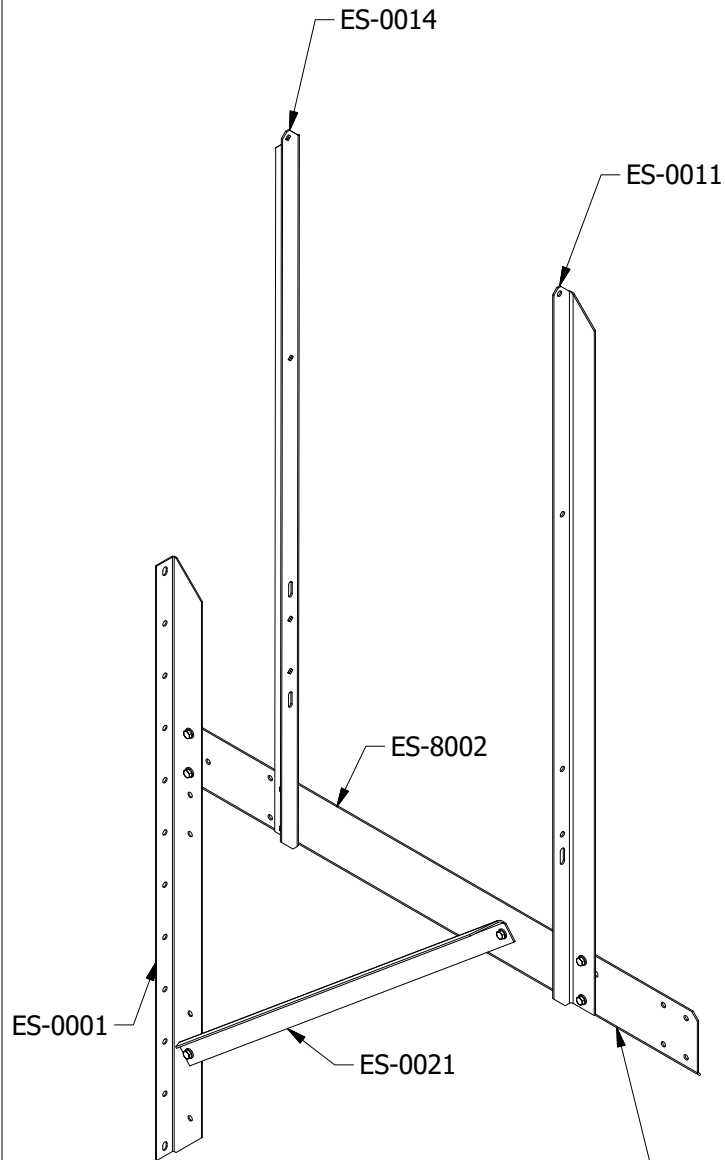

Assemble the lower stair bracket as shown. Trim any excess from ES-8002 after this step is completed.

Fasten the wall bracket to the bin in the desired location.

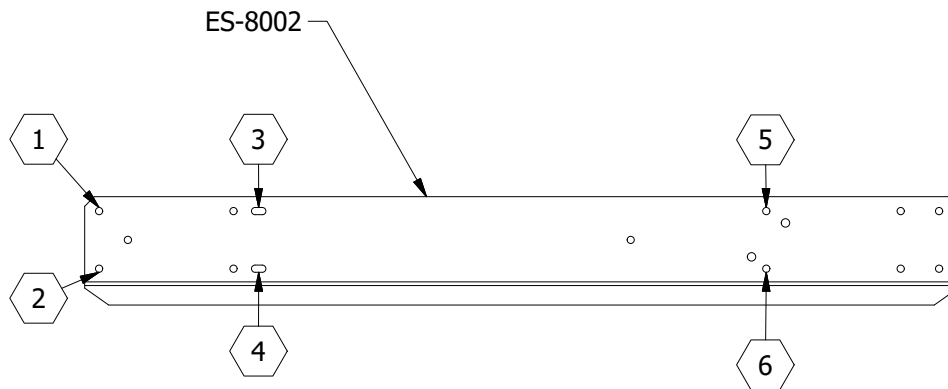

Remove excess cross bar length

DRAWN Marcus	2/9/2018	Greene Galvanized Stairs East Lynn, IL 217.375.4244 www.greenebinstairs.com	
CHECKED		TITLE	
QA			
MFG			
APPROVED			
		SIZE A	DWG NO ES8622_Assembly_Instructions
		SCALE 1/12	REV 5 OF 15

# STEP 2

Hole Patterns for ES-8601 thru ES-8604		
Number of Holes	Part Number	Location Placement
1	ES-8601	Lower Inside
2	ES-8602	Upper Inside
3	ES-8603	Upper Outside
4	ES-8604	Lower Outside

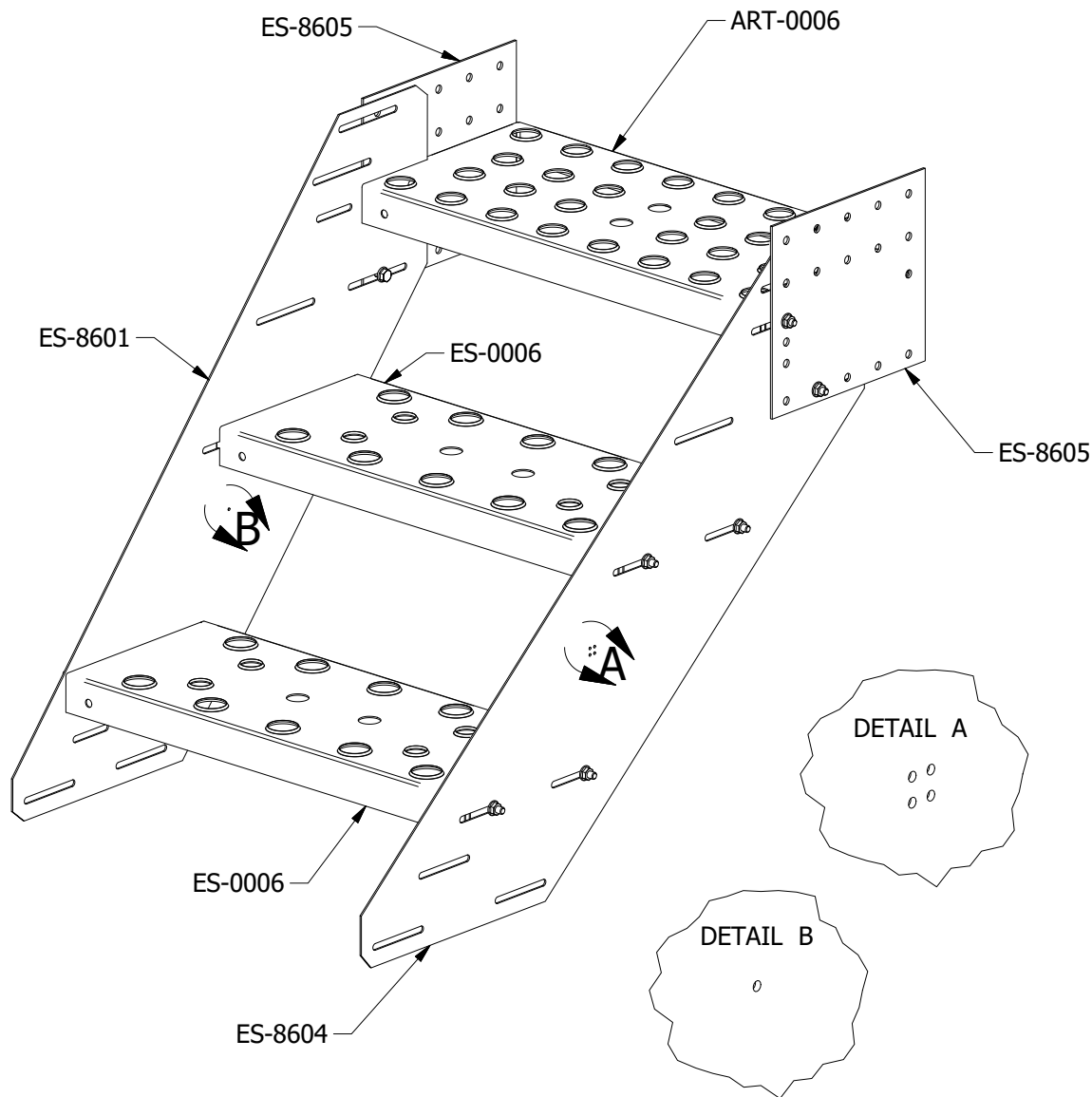

Assemble the lower stair section as shown. Note that the lower two stair treads are ES-0006's and the upper is an ART-0006.

DRAWN Marcus	2/9/2018	Greene Galvanized Stairs East Lynn, IL 217.375.4244 www.greenebinstairs.com		
CHECKED		TITLE		
QA				
MFG				
APPROVED				
		SIZE A	DWG NO ES8622_Assembly_Instructions	REV
		SCALE 1/8	SHEET 6 OF 15	

# STEP 3

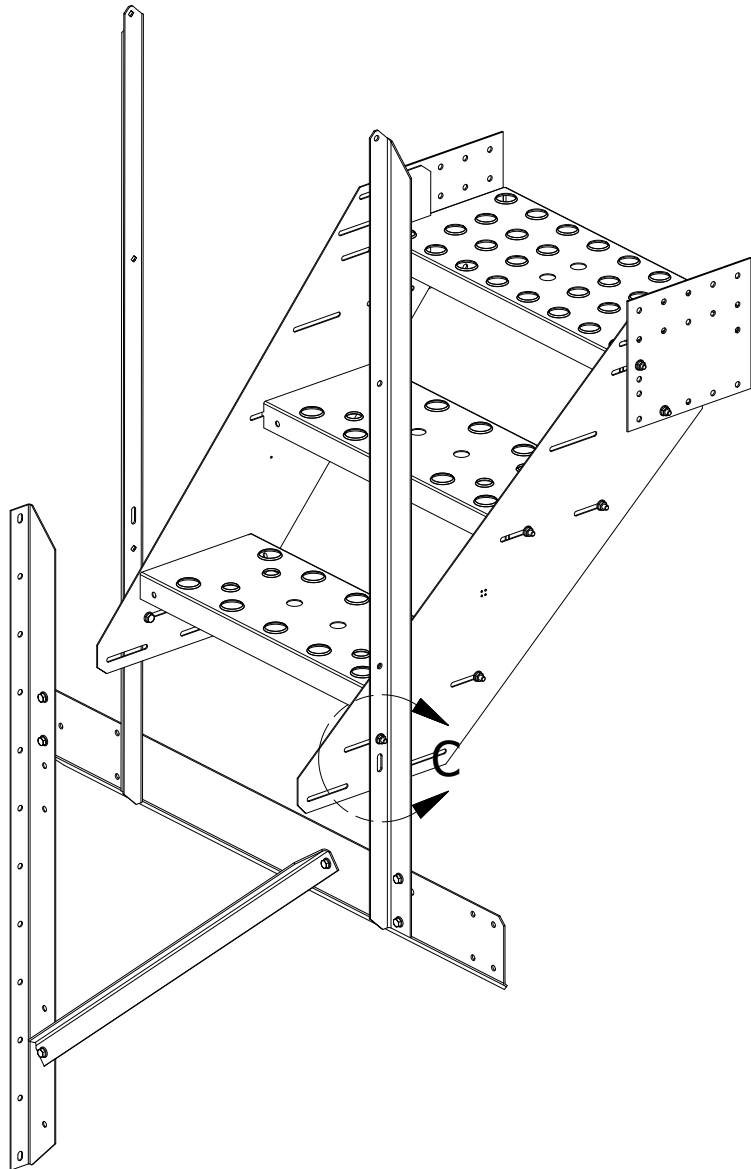

Install the assembled lower stair run to the wall bracket. They are secured to the wall bracket with one bolt on each post, using the second-lowest slot.

DETAIL C

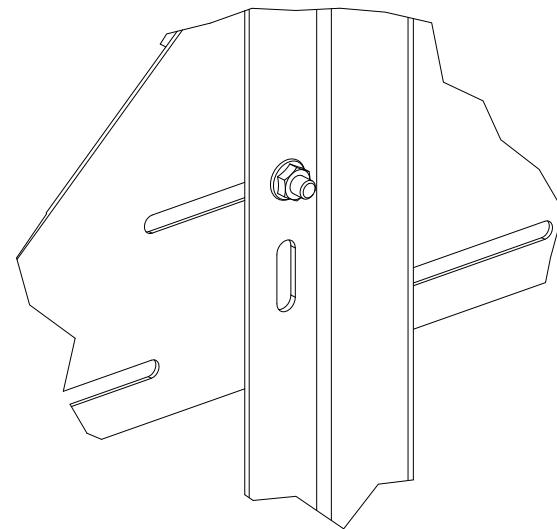

DRAWN Marcus	2/9/2018	Greene Galvanized Stairs East Lynn, IL 217.375.4244 www.greenebinstairs.com	
CHECKED		TITLE	
QA			
MFG			
APPROVED			
		SIZE A	DWG NO ES8622_Assembly_Instructions
		SCALE 1/12	REV
			SHEET 7 OF 15

# STEP 4

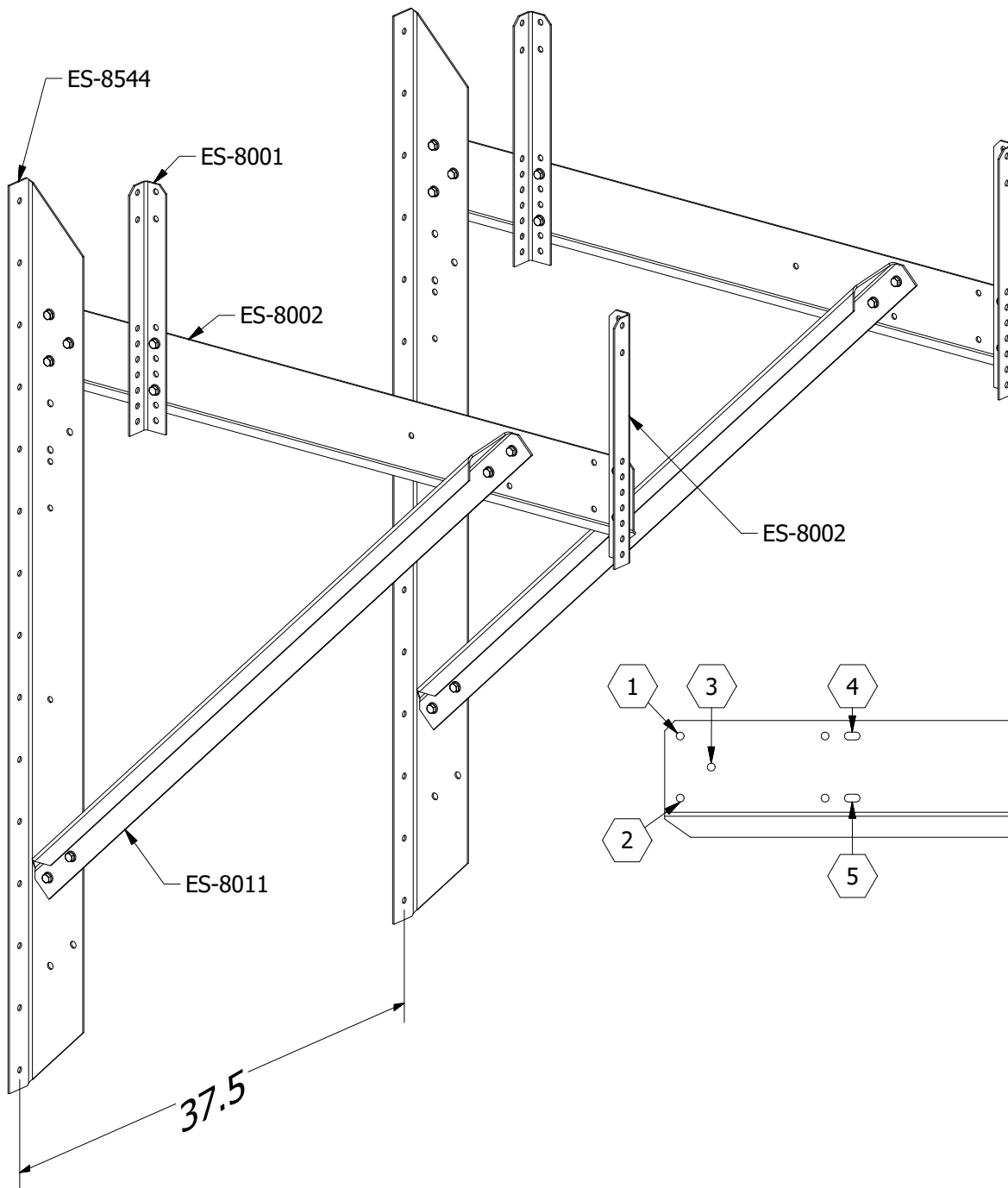

Assemble the two platform wall brackets as shown. They are identical in their bolt hole locations.

Fasten the first (lower) platform bracket four bolt spaces away from the stair bracket, and the second platform bracket four spaces from the first platform bracket.

DRAWN Marcus	2/9/2018	Greene Galvanized Stairs East Lynn, IL 217.375.4244 www.greenebinstairs.com	
CHECKED		TITLE	
QA			
MFG			
APPROVED			
		SIZE A	DWG NO ES8622_Assembly_Instructions
		SCALE 1/10	REV
		SHEET 8 OF 15	



# STEP 5

Begin assembling the platform by securing four ES-8303 posts to the platform skin. For two of the posts, they will be secured with three bolts. For the other two posts, they will be secured with one bolt in this step and two more bolts in the next step.

Attach the two ES-8008 braces to the underside of the platform skin with three bolts each. The bolt heads should be on the surface of the platform, facing down.

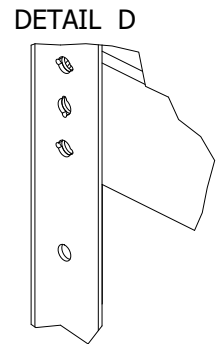
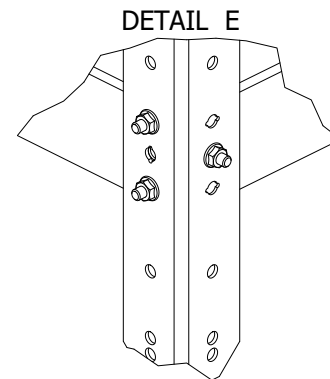
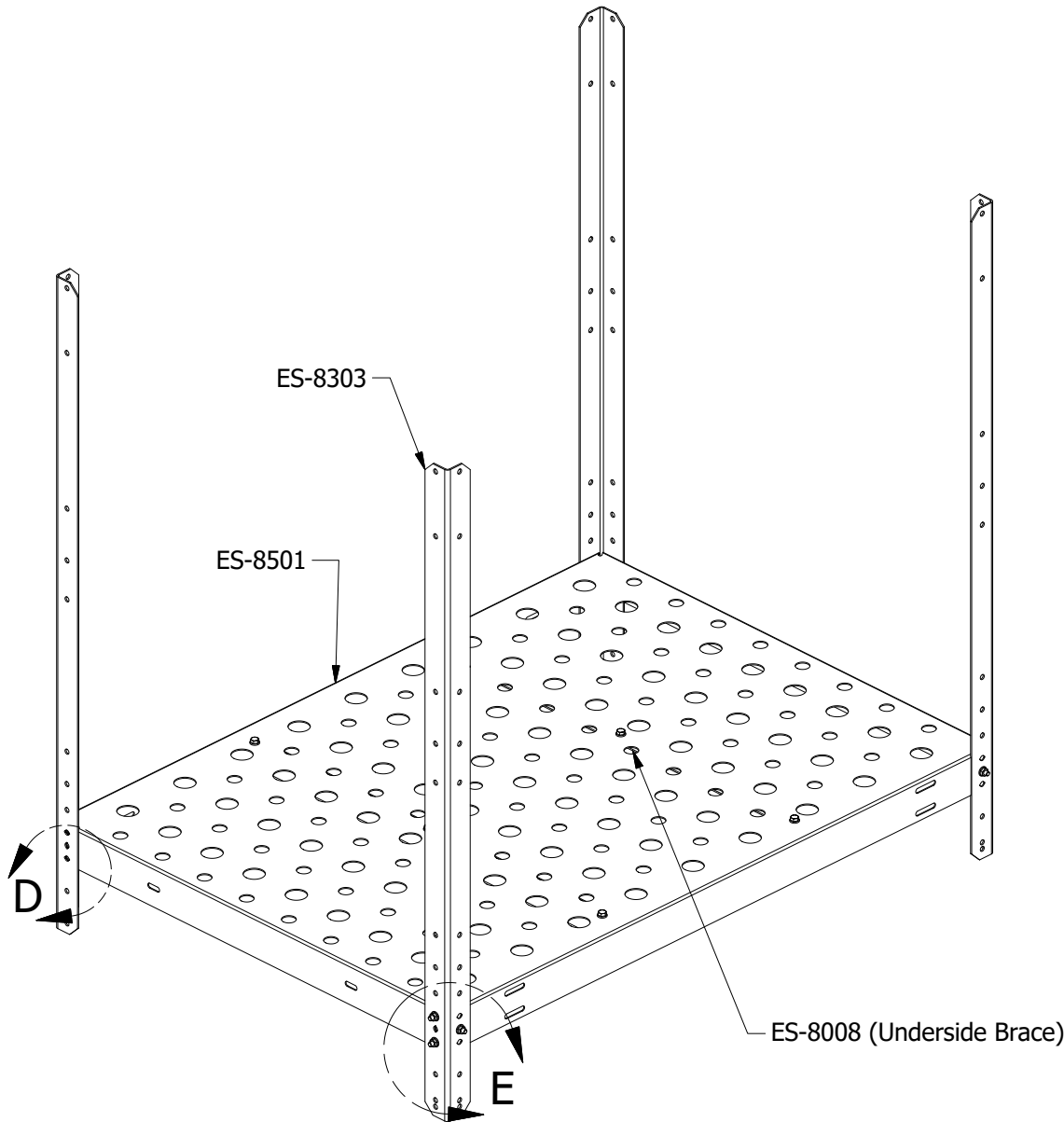

DRAWN	Marcus	2/9/2018	Greene Galvanized Stairs	
CHECKED			East Lynn, IL 217.375.4244	
QA			www.greenebinstairs.com	
MFG			TITLE	
APPROVED				
			SIZE	DWG NO
			A	ES8622_Assembly_Instructions
			SCALE	REV
			1/12	
			SHEET 9 OF 15	

# STEP 6

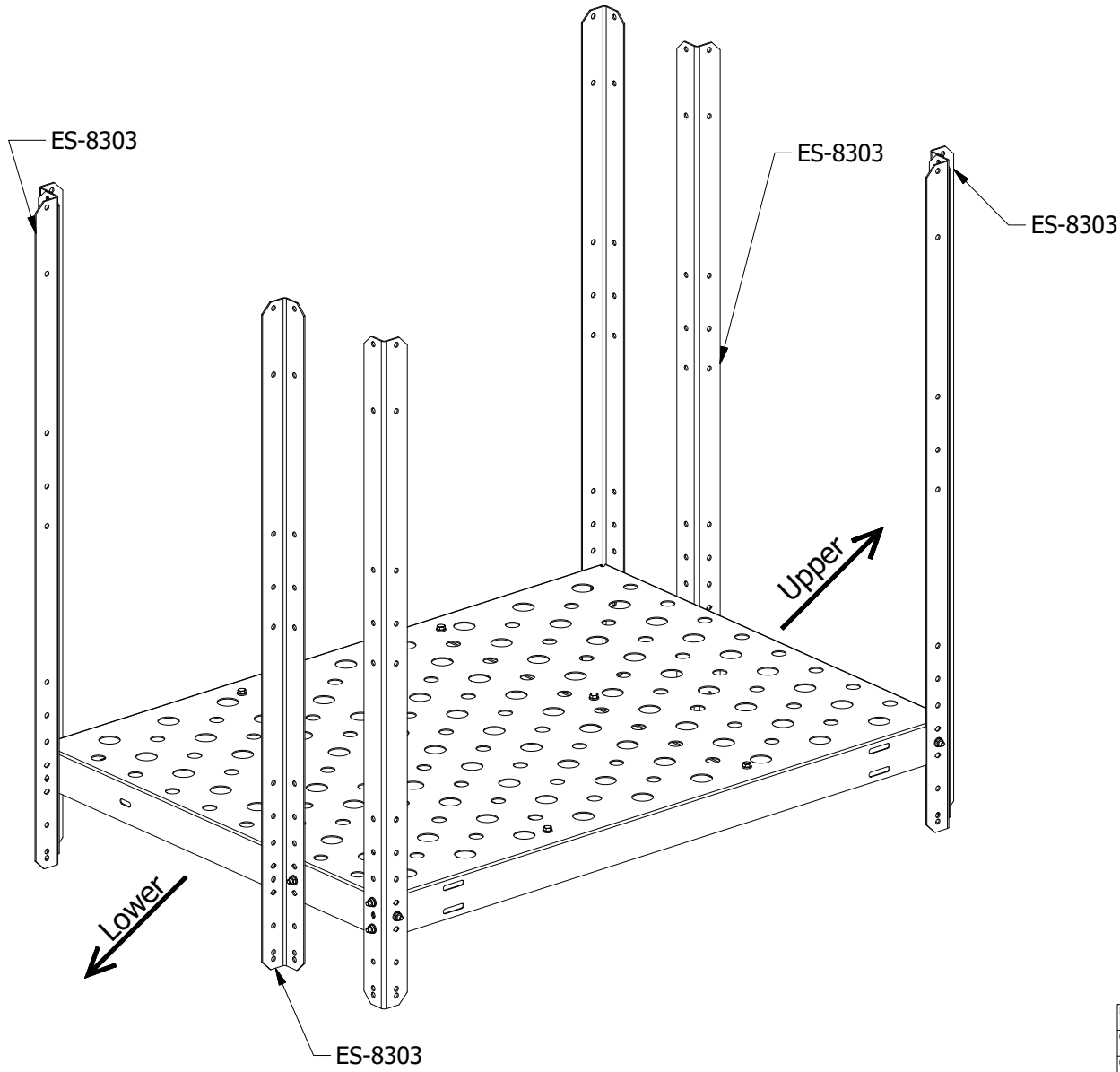

Install four ES-8303 posts as shown. They will be used to secure the stair sections to the platform.

DRAWN Marcus	2/9/2018	Greene Galvanized Stairs East Lynn, IL 217.375.4244 www.greenebinstairs.com	
CHECKED		TITLE	
QA			
MFG			
APPROVED			
		SIZE A	DWG NO ES8622_Assembly_Instructions
		SCALE 1/12	REV REV
		SHEET 10 OF 15	

# STEP 7

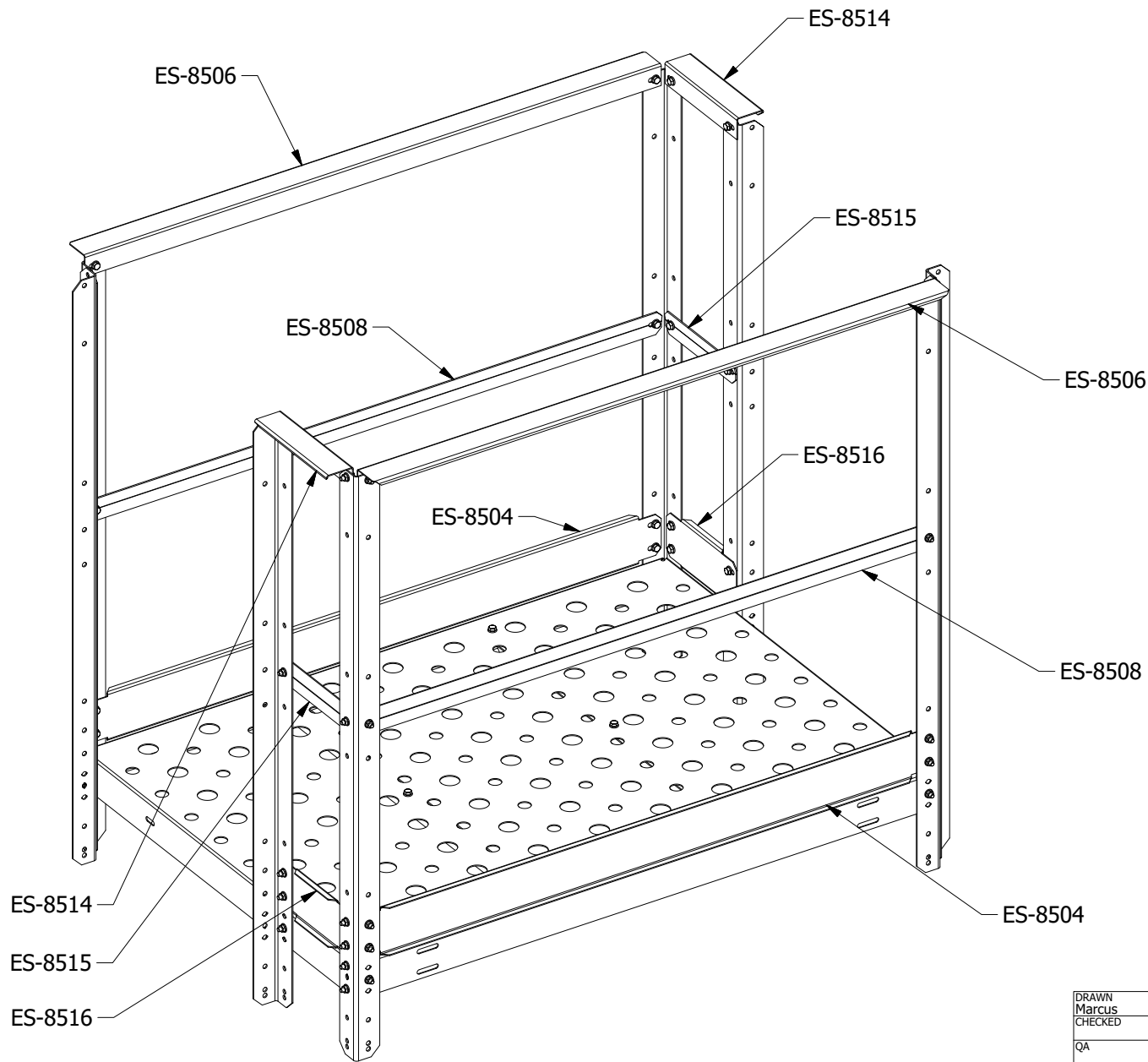

Secure the handrails, intermediate rails, and kickboards to the platform posts using 28 bolts and nuts.

DRAWN Marcus	2/9/2018	Greene Galvanized Stairs East Lynn, IL 217.375.4244 www.greenebinstairs.com	
CHECKED		TITLE	
QA			
MFG			
APPROVED			
		SIZE A	DWG NO ES8622_Assembly_Instructions
		SCALE 1/12	REV 11 OF 15

# STEP 8

Attach the assembled platform to the platform mounting posts and the lower stair run.

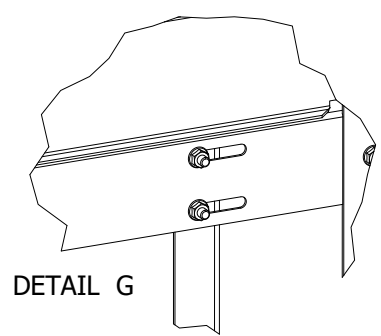
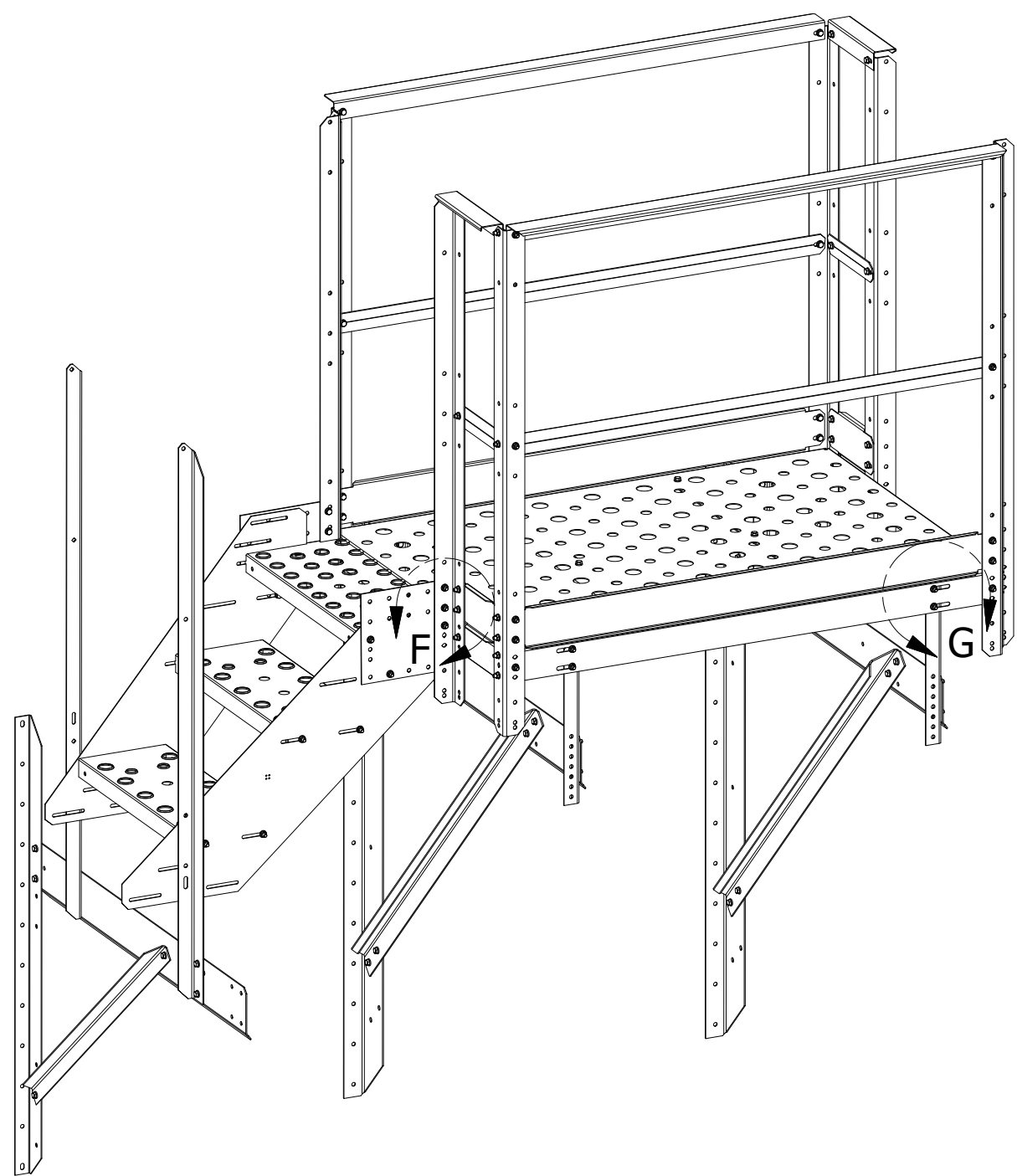

DETAIL G

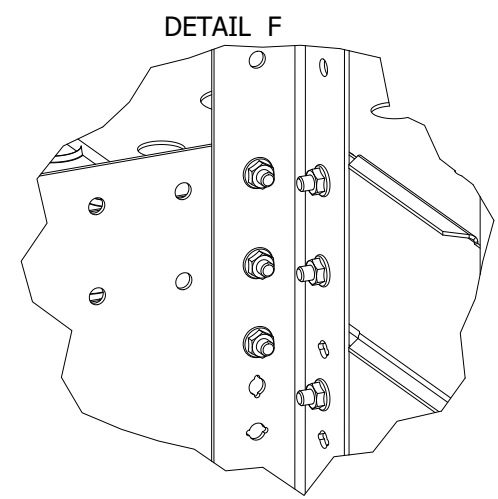

DETAIL F

DRAWN Marcus	2/9/2018	Greene Galvanized Stairs East Lynn, IL 217.375.4244 www.greenebinstairs.com	
CHECKED		TITLE	
QA			
MFG			
APPROVED			
		SIZE A	DWG NO ES8622_Assembly_Instructions
		SCALE 1/15	REV
			SHEET 12 OF 15

# STEP 9

Hole Patterns for ES-8601 thru ES-8604		
Number of Holes	Part Number	Location Placement
1	ES-8601	Lower Inside
2	ES-8602	Upper Inside
3	ES-8603	Upper Outside
4	ES-8604	Lower Outside

Assemble the higher stair section as shown. All four steps are ART-0006's.

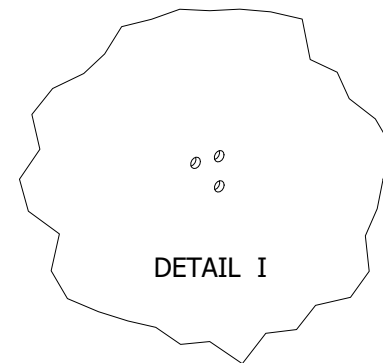
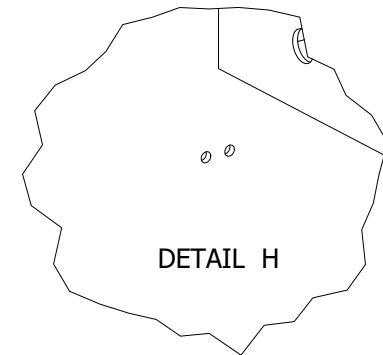
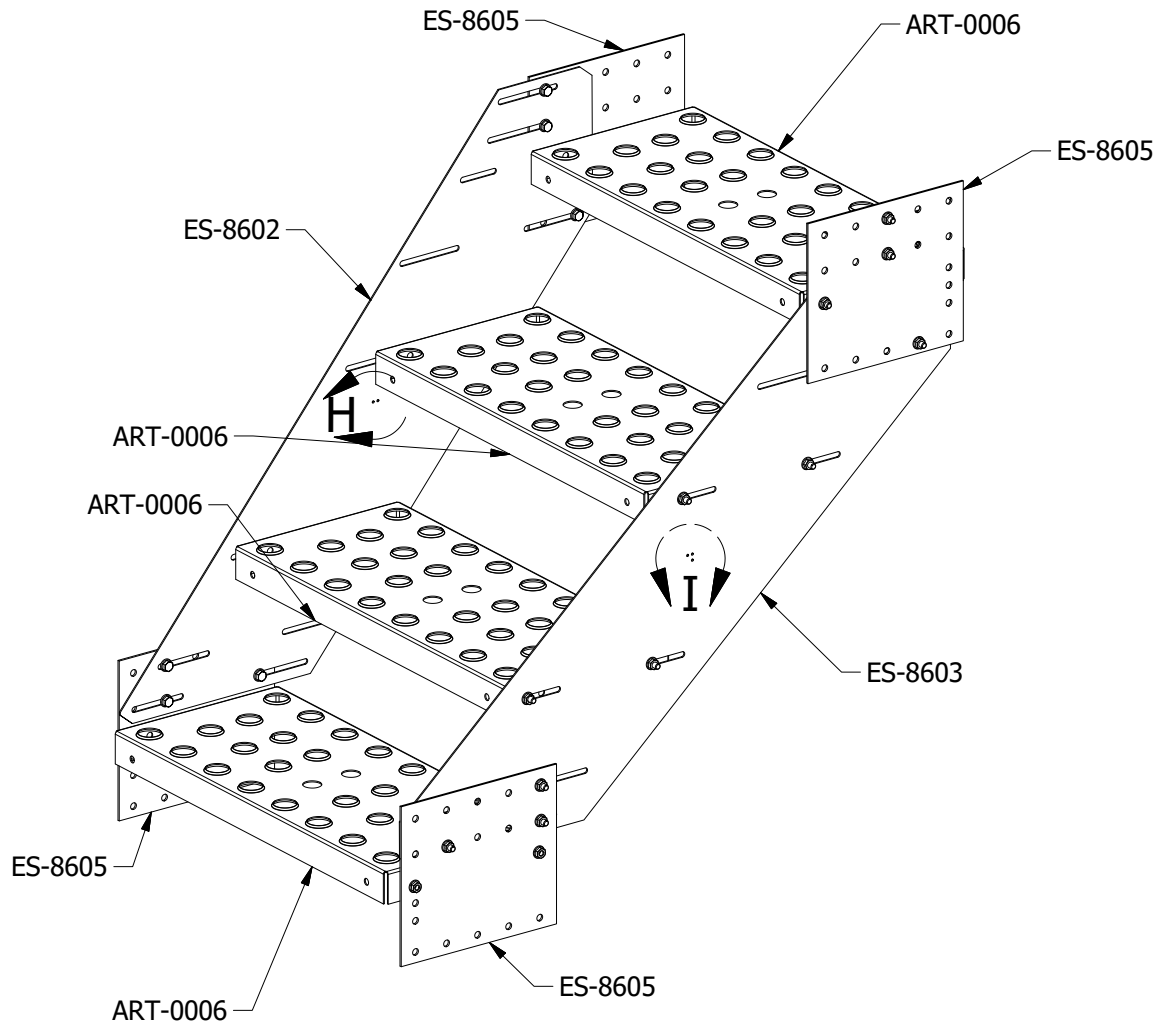

DRAWN Marcus	2/9/2018	Greene Galvanized Stairs East Lynn, IL 217.375.4244 www.greenebinstairs.com	
CHECKED		TITLE	
QA			
MFG			
APPROVED			
		SIZE A	DWG NO ES8622_Assembly_Instructions
		SCALE 1/10	REV REV
		SHEET 13 OF 15	

# STEP 10

ES-8303

ES-8303

Attach two ES-8303 posts to the upper stair section, and attach the upper stair section to the platform as shown.

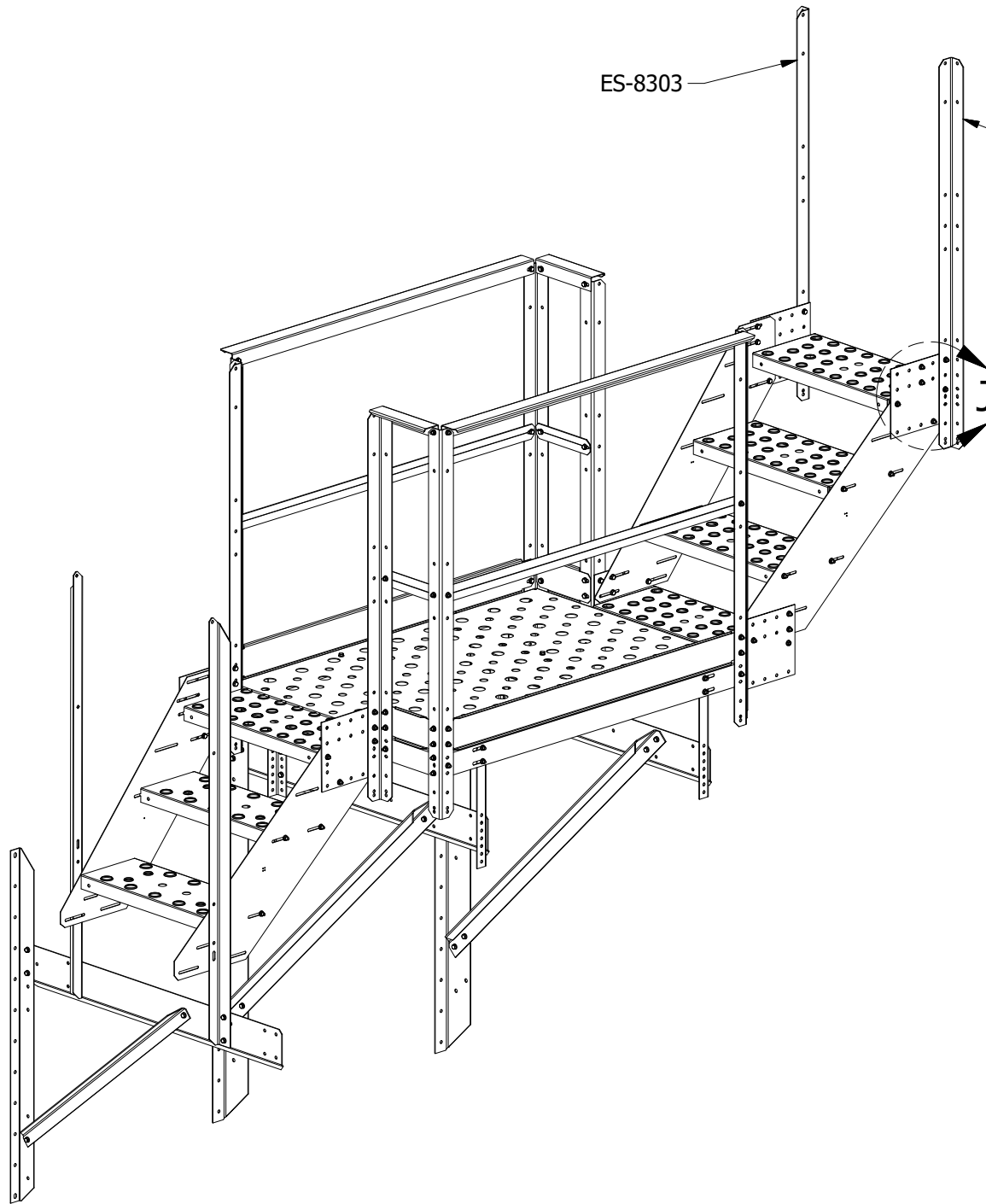

DETAIL J

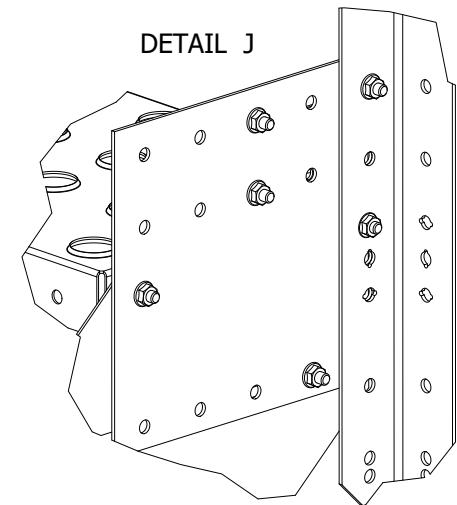

DRAWN Marcus	2/9/2018	Greene Galvanized Stairs East Lynn, IL 217.375.4244 www.greenebinstairs.com	
CHECKED		TITLE	
QA			
MFG			
APPROVED			
		SIZE A	DWG NO ES8622_Assembly_Instructions
		SCALE 1/20	REV 15
		SHEET 14 OF 15	

# STEP 11

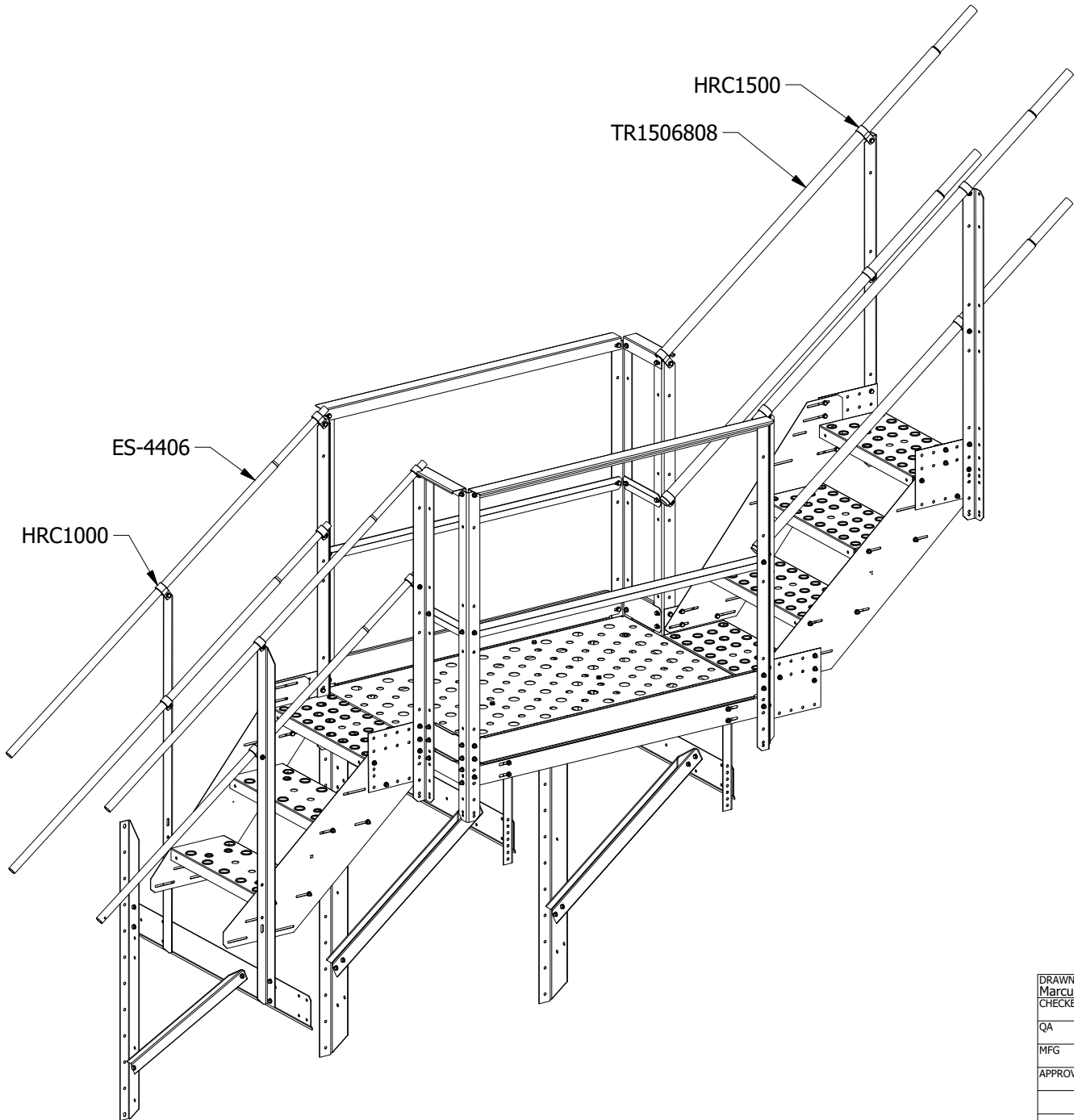

Using the HRC1000 handrail clamps and ES-4406 handrails, install the handrails and intermediate rails on the lower stair section.

Using the HRC1500 handrail clamps and TR1506808 handrails, install the handrails and intermediate rails on the upper stair section.

DRAWN Marcus	2/9/2018	Greene Galvanized Stairs East Lynn, IL 217.375.4244 www.greenebinstairs.com		
CHECKED		TITLE		
QA				
MFG				
APPROVED				
		SIZE A	DWG NO ES8622_Assembly_Instructions	REV
		SCALE 1/22	SHEET 15 OF 15	