

Car Infotainment Systems: A Survey

Ms. Sayali Gupte, Prof. A.R. Askhedkar

VLSI and Embedded MITCOE, Pune, India

Abstract—Automotive industry is expanding at a very fast rate demanding improvements in every possible way. Car manufacturers continuously need to strive hard to make their product better compared to their competitors so as to survive in the market. An infotainment system used in cars is one of the main ECUs. It is too, not spared from the always increasing demand for the improvements from the customers. Every day, advanced features are introduced in infotainment systems such as internet radio, smartphone charging, talk to text etc. In this paper, a comparative study is done between the infotainment systems already available in the market. Also, an innovative design of the infotainment system is proposed introducing a unique feature of wireless connectivity using a smartphone application wherein the tone parameters such as treble, bass, fade, balance and volume can be controlled from the smartphone. This proposed design eliminates the need of head unit thereby reducing the size of the system considerably. It aims at taking the infotainment systems to a different level altogether in terms of size, cost and comfort.

Index Terms—ECU, Head unit, IVI, ADAS, Infotainment, CD.

I. INTRODUCTION

Infotainment systems have evolved through years from a basic AM amplifier to today's high end, intelligent systems. In past, cars did not have any source of entertainment and thus no distraction for the driver other than focusing on the road. Around 1930, radio was introduced in cars after the first radio station appeared in US in late 1920s. However, no customized playlist and average audio quality led to the era of magnetic tapes. They were cheap and small in size and gave passengers the freedom of enjoying their favorite tracks. They were popular in market for over a decade with an acceptable audio quality. Though magnetic tapes ruled market for quite a long time many improvements were not done in audio quality during its entire life span. Meanwhile CD (compact disk) players started gaining popularity in the market thus leading to its introduction in the car industry. It gave far better audio quality than the magnetic tapes and dominated the market for few years. However it started to become obsolete as the smartphones surged in the market increasing its user base rapidly.

Nowadays infotainment systems are getting adapted more to smartphone apps and Internet of Things (IoT) making CD players out of date. Car makers have started to incorporate touchscreen interfaces to their infotainment systems by introducing menu driven screens and apps. This has given rise to

Guided by: Lear Corporation Ltd.

the today's intelligent in-car-entertainment paving a way for new challenges and opportunities for the auto makers. Multiple number of audio inputs are available such as radio, pen drive, Bluetooth, internet etc. Infotainment systems are becoming smarter which not only play music but have features such as GPS, voice control for smartphones, internet radio, parking assistance with touchscreen interface and sensors.

II. EXISTING INFOTAINMENT SYSTEMS

Tech features and distinctive systems are always the selling point for every car brand however most of them are more or less similar. At times there are slight differences in every car model of same brand. The mainstream car brands include Chevrolet, Jeep, Fiat, Honda, Hyundai, Nissan, Toyota, Volkswagen etc. GPS, auxiliary audio jack, bluetooth, USB are the common features found in the basic music systems of these brands.

MyLink, Uconnect, SYNC3 are the interface names for Chevrolet, FIAT and FORD respectively. Brands like GMC, Mazda, and Toyota also have their interfaces customized to names like Intellink, Mazda Connect and Entune respectively. All these system have touchscreen with screen sizes varying from 5 inches to as large as 8 inches in higher end models of Nissan. Knob and button controls are provided on center console in Mazda and Mini and redundant dash-mounted knob controls are provided in FIAT.

Many car manufacturers have incorporated car play in their infotainment system. Apple car play is an apple standard that allows user to use their iPhone in the car. It connects iPhone directly to the cars infotainment display and has features such as GPS, making call, reading messages, music player and so on. The reason behind popularity of Car Play is that it can be added to the current design with an aftermarket system. A similar standard for Android OS is developed by Google known as Android Auto. When an Android device is connected to the compatible head unit using Android auto then the user can broadcast apps such as GPS, SMS, web search etc. on the systems display. Internet radio like Pandora, Sticher, iHeartRadio, Spotify are common these days. The other noticeable features include customizable menu layout,

3G and 4G, LTE WiFi, wireless smartphone charging, remote vehicle control. From security and safety point of view, features like teen driver settings, talk-to-text, automatic post-collision 911 calling (via your phone), car-finding app are

available. Some unique features like maintenance reminders and online manuals are also provided by Honda.

III. RELATED WORK

Hand gesture recognition is also used in infotainment systems.[1] has work contribution wherein free-hand gestures are used to control the infotainment system. Hand gestures are recorded using a Creative Gesture Camera(CGC). Point cloud which is the extension of 3D data points is divided into cubes of fixed size which is then fed to the Convolutional Neural Network (CNN). CNN extracts the necessary information in the form of filters for the task of object recognition. The hand gesture database is shown in fig 1. These hand gestures are used for controlling the infotainment system for example, to switch radio channels, interact with audio or to choose elements.

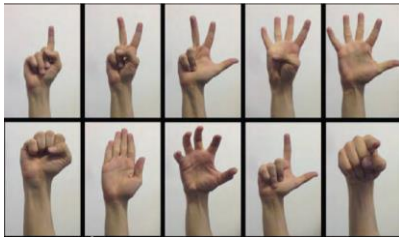

Fig. 1. Hand gesture database consisting of different gestures: ONE, TWO, THREE, FOUR, FIVE, FIST, FLAT, GRAB, PINCH, POINT

Highly interactive infotainment systems need drivers attention and results in increasing distraction and accidents. From safety point of view,[2] describes a design which reduces the driver distraction by introducing additional modes to the traditional speech- recognition system. From passengers point of view, ADAS is one of the important units. The real time communication between IVI (In- Vehicle Infotainment) and ADAS is important. A communication solution is proposed in [3] which uses Ethernet to communicate between ADAS and IVI.

IV. PROPOSED DESIGN

The proposed design gives a unique idea for an altogether different experience to the user. The head unit in the traditional infotainment system is replaced by the Android phone as most of the people nowadays have a smartphone. This design enables the user to control the entire music system just by using his smartphone [4]. An Android application is developed to control the music system. A basic block diagram is depicted in fig 2. The user needs to install this app in the Android smartphone and the system is ready to be used.

The state of the art is that there is no need of head unit on the dashboard which has all the controls in the form of touch screen or knobs as in the earlier systems. Parameters like volume, previous, next can be controlled through the application. Not only this but tone parameters such as bass,

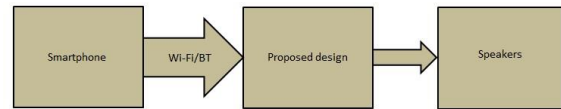

Fig. 2. Block diagram of proposed design

treble, fade and balance can also be controlled giving a high quality audio experience. The entire idea focuses on developing a high end infotainment system with Bluetooth and Wi-Fi connectivity making the complete system wireless as well as user friendly. The car manufacturers can install this wireless amplifier and the customers can readily use this music system by connecting their smartphones to it through Wi-Fi or Bluetooth. Speech recognition is also suggested in [5]. A detailed block diagram is shown in 3.

V. OBJECTIVES

The main objective of this idea is to develop a infotainment system at low cost than the existing systems. Low cost is the major factor which makes it cost effective for auto makers to incorporate this system in their car design. From the customers point of view this is beneficial as they dont have to purchase a separate music system and the cost to be paid is also lower than other infotainment systems available in the market.

Now a days, systems are so designed so as to occupy minimum space as possible. Thus, the proposed design is aimed at reducing the size of the music system considerably. The head unit which occupies considerable space on the dashboard is not required anymore. This saves a lot of space on the dashboard opening up a great opportunity for car designers to incorporate other functionalities in the design by utilizing the available space. Thus size reduction is one of the major objectives of this project.

Due to the rapid development in the field of IoT and technology scaling, customer needs are also increasing rapidly. Thus, providing comfort and luxury becomes important. Proposed design also aims at giving comfort to the customers and making the system user friendly.

VI. IMPLEMENTATION

As seen from the block diagram, Android application, WiFi and Bluetooth module, Microcontroller, DSP, Power amplifier and speakers are the main components of the system. Similar type of system is described in [6].

The Android application has Bluetooth and WiFi feature. Smartphone is connected to the system using this app. Once the mobile and system are connected with each other, user can change the audio settings using the app. Sliders are available to change volume, bass, treble, fade and balance. Depending on the position of the slider, signals are sent through the wifi/Bluetooth module to the controller. This communication occurs using UART (Universal asynchronous receiver transmitter). Once the corresponding signals are received they are

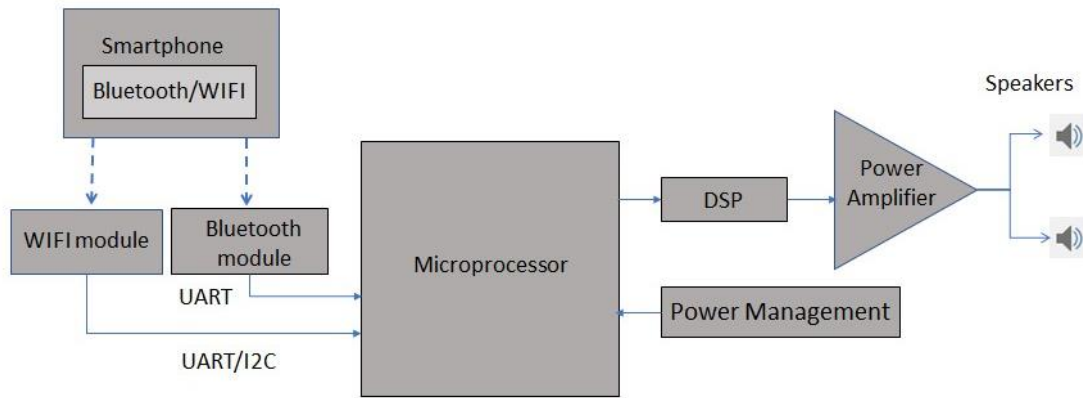

Fig. 3. Detailed block diagram of proposed design

used to control the DSP. It can control volume, bass, treble, fade and balance and it is serially controllable via I2C. DSP performs required operations and music is sent to the amplifier. In the final stage, the amplified music is fed to the speakers and played. As a prototype only two speakers are shown, however it can be scaled to four speakers easily as well as the amplifier improved further in terms of power ratings.

VII. CONCLUSION

The car-infotainment systems are developing over the past few years. So the car manufacturers are constantly trying to improve their infotainment designs and to incorporate as many functionalities as possible. It includes Bluetooth connectivity, USB, radio etc. This paper describes a unique idea for such infotainment system which eliminates the need for a head unit considerably reducing the size of the entire system. The available market solutions are costly and so the main objective of this project is to reduce the cost as much as possible. It aims at developing a system which is wireless and user friendly. It can be controlled through a smart phone app and the control parameters include volume up, down, bass, treble, fade and balance.

REFERENCES

- [1] F. Sachara, T. Kopinski, A. Gepperth, and U. Handmann. Free- handgesture recognition with 3d-cnns for in-car infotainment control in real-time. In 2017 IEEE 20th International Conference on Intelligent Transportation Systems (ITSC), pages 959-964, Oct 2017.
- [2] A. Gaffar and S. M. Kouchak. Minimalist design: An optimized solution for intelligent interactive infotainment systems. In 2017 Intelligent Systems Conference (IntelliSys), pages 553-557, Sept 2017.
- [3] K. Omerovic, J. Janjatovic, M. Milosevic, and T. Maruna. Supporting sensor fusion in next generation android invehicle infotainment units. In 2016 IEEE 6th International Conference on Consumer Electronics - Berlin (ICCEBerlin), pages 187-189, Sept 2016.
- [4] B. Kovacevic, M. Kovacevic, T. Maruna, and D. Rapic. Android4auto: A proposal for integration of android in vehicle infotainment systems. In 2016 IEEE International Conference on Consumer Electronics (ICCE), pages 99- 100, Jan 2016.
- [5] A. Nilakhe and S. Shelke. A design for wireless music control system using speech recognition. In 2016 Conference on Advances in Signal Processing (CASP), pages 337-339, June 2016.
- [6] Z. Bingxiang, L. Jiaqing, W. Shouting, and K. Zhongming. The design of intelligent music system based on internet of things. In 2016 IEEE International Conference of Online Analysis and Computing Science (ICOACS), pages 7-10, May 2016.