

GT2 - TIMBER FRAMED PAIRED GLASSWALL PANELS

WARRANTY

Hufcor Partitions are guaranteed against defects in material and workmanship for a period of one year, excluding any abuse to the product.

The Hufcor Partitions for this installation have been custom made to the architect and owner's specifications. Each partition has been carefully fabricated and installed to provide many years of trouble-free service.

The key to the life of the product is proper operation and care. The correct operation and recommended care are outlined in this Owners Manual for your guidance.

If any malfunction of these partitions occurs, please phone your local Hufcor Distributor for service. This must be done immediately since Hufcor cannot be responsible for damages that result from delays or failure to advise Hufcor or Hufcor's local Distributor.

This partition was sold and installed by:

When calling either your Hufcor Distributor or Hufcor, please have the following information:

Job Name:

Hufcor Order #:

Installation Date:

Description of the Problem:

Person to Contact:

How To Operate Timber Framed Paired Panel Partitions

Paired panel partitions consist of panel groups hinged together and supported by a carrier on each panel. Panels have vinyl sweeps top and bottom.

CAUTION: DO NOT MOVE ALL PANELS TOGETHER IN THE MIDDLE OF THE TRACK. YOUR OVERHEAD SUPPORT SYSTEM MAY NOT BE STRONG ENOUGH TO WITHSTAND THE WEIGHT. IF YOU NEED TO MOVE THEM FROM THEIR STORAGE AREA, OPEN THEM OR SPREAD THEM OUT ALONG THE TRACK.

Setting Up A Partition

1. Stand in the center of the partition and face the first group of panels. Using both hands grasp the edges of the first panel.
2. Gently pull the panel group along the track in its folded position far enough to permit unfolding the panel group. Put slight pressure near the hinge joint as the panel group flattens in order to engage the face activated floor pins at the hinge point. (Fig. 1)
3. Move each panel group down the track towards the opposite jamb or previously positioned panel group. (Fig. 2) Slow the momentum to a stop as you position the panel with the wall or previously positioned panels.
4. **Throw bolt Operation.** Once the panels are in position; engage the edge activated throw bolt on the trail edge of the vertical rail. You will also need to engage the face activated throw bolt of the lead panel in the pair.
This face pin is located at the trail end of the face of the bottom rail. This will engage the throw bolt into the floor plate mounted on the floor.
5. Repeat the previous steps until all panel groups are done, with the exception of the last group. See Step 6.
6. **Setting the Final Panel Group.**
 - a. **Trail Panel Group**
Move the last panel(s) into place and flatten out. Slide panels forward so lead panel engages with the previous panel. Engage the face activated throw bolts on the lower faces of the trail side of the vertical rail of each panel. There will be a gap from the trailside of the trail panel to the wall that is necessary to set up and stack the panels.
 - b. **Optional Hinged Closure Panel**
The hinged closure panel is a full height panel that functions similar to a typical building door. When all panels in the opening have been sealed in place, close the closure panel.

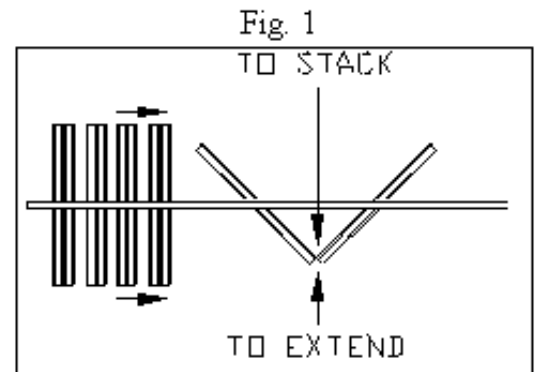

Fig. 2

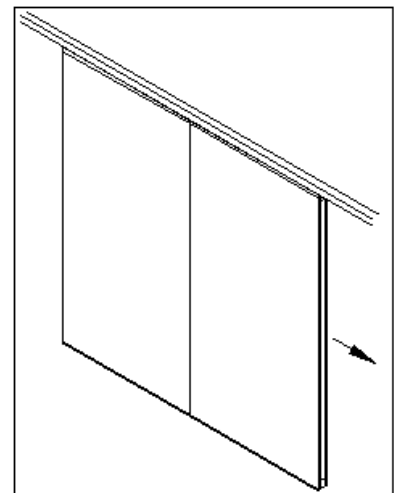
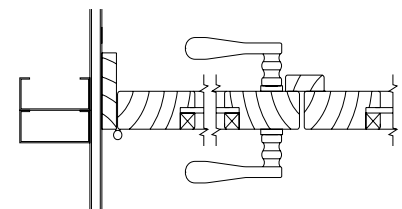

Fig.3



Optional hinged closure panel:

Stacking The Partitions

1. Retract the throw bolts located at the trail end of the bottom rails of the last paired group. This will release the throw bolts from the floor receivers and allow the panels to be moved. Slowly fold the group and push the pair back to the stack side of the partition run until it rests against the wall or hinged closure panel if supplied.
 Optional Hinged Closure Panel: Open closure panel as far as it will go.
2. Retract the edge activated throw bolt of the trail panel and face activated throw bolt of the lead panel. This will release the throw bolts from the floor receivers and allow the panels to be moved.
3. Disengage panels from adjoining group and move each group in the flat position down the track towards the stack area (Fig. 2).
5. Fold panels just in front of the stack area by pushing directly in the center of the panel on the hinged side while holding the lead edge firmly. When the panels break from the flat position, move in front of the panel group and guide the panels flat. (Fig. 1)
6. Stand in front of the panel group facing the stack, and firmly grasp the edge of the panel group. Slowly move the group into the stack until the first group rests against the wall. Repeat Steps 3 - 6 until all panel groups are at rest in the stacked position.

CARE AND MAINTENANCE

Wooden timber frames:

Hufcor Timber framed panels are shipped unfinished to be finished by others in the field. The field finished surface of your Hufcor partition may only be cleaned according to the contracted finishers instructions.

CAUTION: Do not use anything except what is recommended by the contracted finisher.

Clear Glass Surfaces:

The clear glass can be cleaned with standard glass cleaners.

CAUTION: If the glass as etching or has any special decorations, see specific cleaning instructions supplied with the panel shipment.

DAMAGE: Your Hufcor partition is of a unique construction that permits replacement of individual parts. Report all damage promptly to your local Hufcor Distributor.

TROUBLESHOOTING GUIDE

PROBLEM	CAUSE	TREATMENT
Panels hanging out of plumb	1. Loose or broken trolleys 2. Broken trolley support beam	1. Tighten loose carriers to return panel to plumb. 2. Replace broken carrier or support beam
Panels sticking or hard to move	1. Dirt in the track 2. Misaligned track joints 3. Broken trolley	1. Clean track 2. Align joints 3. Replace trolley
Abnormal noise during movement	1. Broken trolley 2. Misaligned track joints	1. Replace trolley 2. Align joints
Broken or worn trolleys	1. Bad track joints	1. Realign track joints. Replace trolleys. 2. Replace trolleys and retrain personnel

RECOMMENDED PREVENTIVE MAINTENANCE

We strongly recommend that you contact your Hufcor Distributor to perform an annual inspection for your partitions (six months if your partitions are used daily). Regular maintenance will keep your partitions in good working condition and make certain they perform properly for many years to come. An annual inspection includes:

1. Clean and lightly lubricate all track running surfaces.
2. Check trolleys for any signs of abnormal wear or breakage. Replace as needed.
3. Check out-of-plumb panels (indicating loose trolley bolts). Correct by adjusting to plumb and tightening trolley nuts.
4. Check track misalignment at all joints and intersections - correct any misalignment.

Hufcor, Inc.
PO Box 591, 2101 Kennedy Rd., Janesville, WI 53547
800/356-6968; Service & Installation Dept: 800.542.6870 or 608.756.1241; FAX: 608.756.1246
Website: www.hufcor.com