

# PRODUCT DATA SHEET

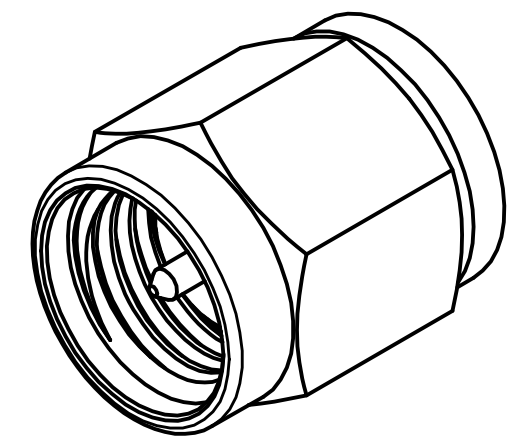
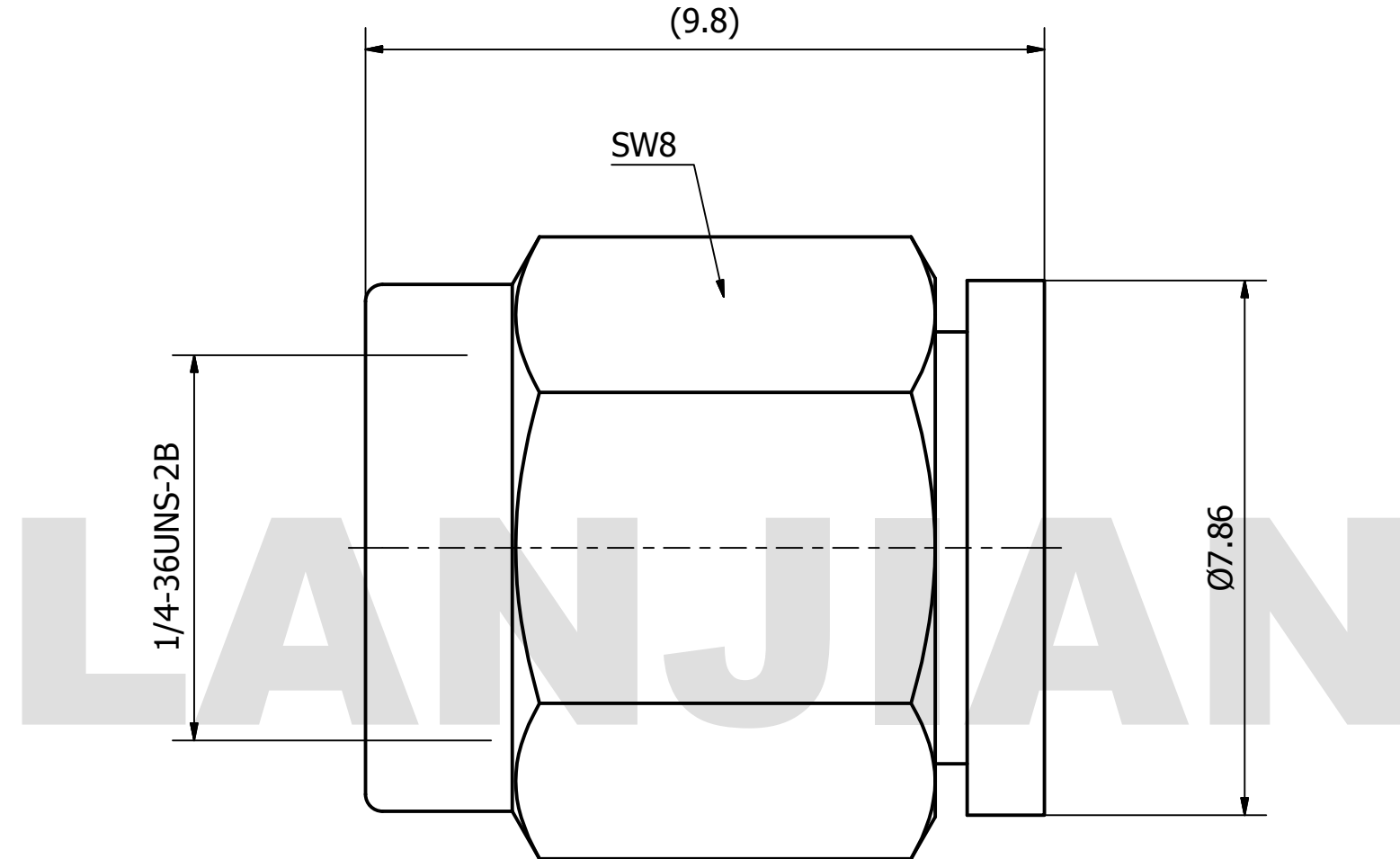

**MATERIAL:**  
 BODY: STAINLESS STEEL PER AMS-5640,  
 ALLOY UNS S30300  
 CONTACT: STAINLESS STEEL PER AMS-5640,  
 ALLOY UNS S30300

THIS DOCUMENT CONTAINS CONFIDENTIAL AND PROPRIETARY INFORMATION THAT CANNOT BE REPRODUCED OR DIVULGED, IN WHOLE OR IN PART, WITHOUT WRITTEN AUTHORIZATION FROM "LANJIAN ELECTRONICS"	MATERIAL :		
	UNLESS OTHERWISE SPECIFIED: DIMENSIONS IN MM		
	TOLERANCES :		
	X.X	± 0.20	ANGULAR : ± 1°
	X.XX	± 0.10	FILLETS R/C : ± 0.10
	X.XXX	± 0.01	SURFACE FINISH : Ra 1.6
			DEBURR AND BREAK SHARP EDGES
		NAME	DATE
	DRAWN		
	CHK'D		
APPV'D			
MFG			
PROJECTION		SIZE	SCALE
		A3	10 : 1

38 Hengtong Road, Xinqu Dingmao  
 Zhenjiang, 212009, Jiangsu, P. R. China

TITLE	
SMA-SHORT short-circuiter	
DWG No. GCPZ3.650.A.008	REV.
DO NOT SCALE THE DRAWING	PAGE 1 / 1