



COMPU-AIRE INC.
Specialized Environmental Air Conditioning Systems

MAXI-KOOL

Installation & Operation Manual

Split & Package Systems

2 to 20 Ton

Air Cooled (**MKA**)

Water Cooled (**MKW**)

Glycol Cooled (**MKG**)

Chilled Water (**MKC**)

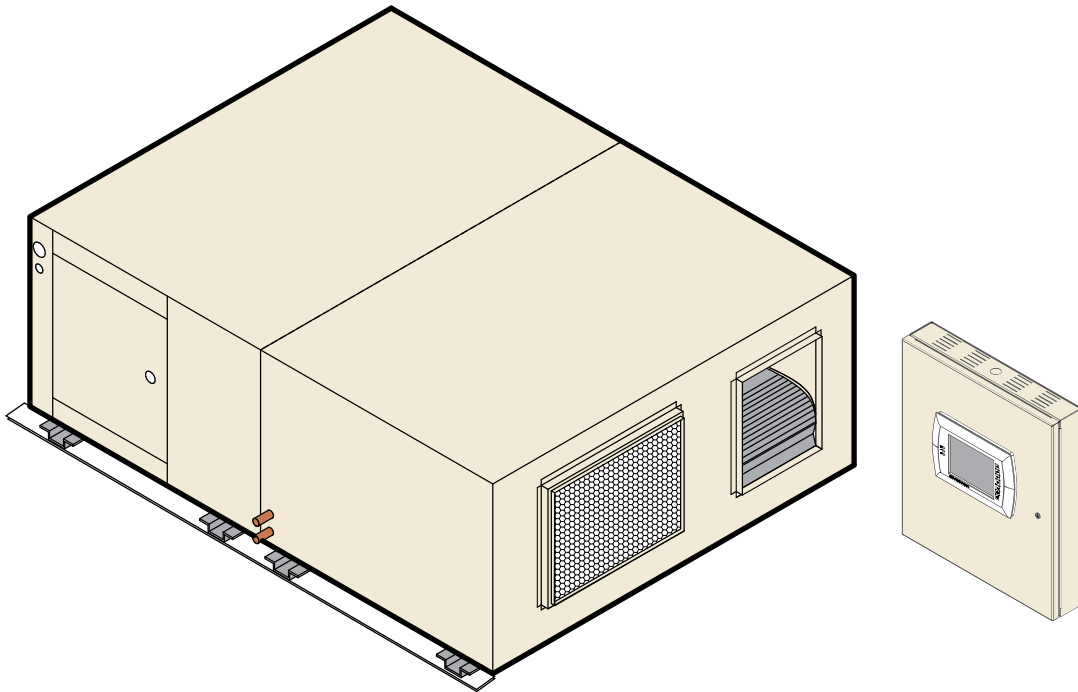

ISO 9001:2008
CERTIFIED



INDEX

DESCRIPTION	PAGE
1. INTRODUCTION	1-2
2. INSTALLATION GUIDELINES	2-9
3. TYPICAL FIELD WIRING	10
4. DIMENSIONAL DATA	11-13
5. TECHNICAL AND ELECTRICAL DATA	14-17
6. WIRING DIAGRAMS	18
7. CONDENSATE DRAIN	24
8. LOW AMBIENT CONTROLS	25
9. STEAM GENERATOR TYPE HUMIDIFIER	25-33
10. START-UP	34-35
11. REMOTE CONTROLS	35
12. MAINTENANCE	36
13. SPARE PARTS LIST	37-39
14. WARRANTY CERTIFICATE	40

INTRODUCTION

MAXI-KOOL

An air conditioner specifically engineered for mini-computer environments and its usefulness extended to spot cooling for any room, any need.

MAXI-KOOL's ceiling mounting allows you to position the unit where it is needed the most thereby reducing cost of long runs of duct work and other related expenses.

MAXI-KOOL provides complete control of temperature and humidity requirements practically anywhere simply and economically.

MAXI-KOOL is usable in:

- a) Mini computer rooms
- b) Any hot spot application such as: Hospitals, laboratories, banks, communication rooms, libraries, foyers and many other special applications.

MAXI-KOOL is designed to be serviceable in place without any rigging devices or service winches thereby eliminating the necessity of undoing electrical and refrigerant connections.

MAXI-KOOL utilizes a variable drive package for the evaporator and condenser sections for ease of field adjustment ability to match specific external static pressure requirements.

Ceiling duct-work can easily be relocated without relocating the air conditioner which allows easy relocation of air distribution devices such as ceiling diffusers and grilles.

CABINET

Cabinet is constructed of heavy gage galvanized steel. The frame of the unit is constructed of steel channels for floor mounting or ceiling mounting with hanger rods.

The evaporator and condenser section of the Air Cooled units are constructed so they can easily be field separated for ease of installation in tight spaces or installation of the two sections in different parts of the building.

FANS

The evaporator and condenser fans are double width, double inlet, centrifugal type. Each fan assembly is properly dynamically and statically balanced and uses a heavy duty stainless steel shaft with permanently lubricated bearings.

The fan motors are internally protected and 1750 rpm. The drive set is of the variable pitch type.

Both fans are located on the down stream side of the coils for proper air flow over the cooling surface for maximum heat transfer.

COILS

Coils are constructed of copper tubes and high efficiency aluminum fins. The evaporator coil is provided with an epoxy coated galvanized steel condensate pan. Condensate pan is provided with a moisture sensing device which when triggered will shut the unit off and send a signal to the remote control panel.

FILTERS

MAXI-KOOL units are supplied with 2" (or optional 4") – 30% pleated FILTERS.

COMPRESSOR

Each refrigerant circuit is provided with an externally equalized expansion valve, filter dryer, sight glass, manually reset high pressure switch, auto reset low pressure switch, schrader fittings for discharge and suction lines.

HUMIDIFIER

The humidifier is of the self contained disposable cylinder type. It is factory piped and wired in the unit. The only field connection required is the water connection.

REHEAT

The reheat coil is of the low watt density finned tubular type and is equipped with dual protection. Reheat is factory installed on the down stream side of the evaporator coil.

ELECTRICAL CIRCUIT

All high voltage electrical control components are located in an easily accessible control box inside the unit. Various electrical components can be accessed while the unit is operating. Each electrical component such as fan motors, compressor(s), reheat, and humidifier is individually protected with branch circuit fuses.

CONTROLS

The Control System is microprocessor based. A solid state, remote, wall mounted MCP -System 2000 is provided as standard Controls.

The MCP-System 2000 is dual display digitally operated controller having capability of controlling the Air conditioner so that the room temperature and humidity can be maintained within the selectable dead bands and set points.

The primary display consists of multi-character alpha-numeric LCD which indicates the unit operating mode at all times. The return air temperature and humidity is also displayed. A secondary display consisting of LED indicators indicates operating modes and malfunctions.

INSTALLATION GUIDE LINES

MAXI-KOOL units are designed to meet various air conditioning requirements. MAXI -KOOL unit lends itself to be mounted on the floor or suspended from the ceilings. For ease of passage thru tight spaces unit can be turned on its sides (extreme care should be exercised while turning the unit on its side).

The MAXI-KOOL Air Cooled is also available as split system [(MKA -(E) and (C)]so that the condensing section may be installed remotely from the evaporator section. Evacuation and balancing of refrigerant charge must be done in the field, and R-22 refrigerant to be field provided. Split units are shipped with a holding charge only.

GENERAL SAFETY INFORMATION

- a) Installation and maintenance are to be performed by qualified personnel only.
- b) Assure all field wiring conforms to the requirements of the equipment and all applicable national and local codes. Assure the voltage on the unit name -plate agrees with the power supply available.
- c) Avoid contact with any sharp edges. It may cause serious injury.
- d) Make all power sources are disconnected before any service work is performed on the equipment.

INSPECTION

- a) Check all items against the bill of lading to make sure all crates and cartons have been received.
- b) Inspect all items for either visible or concealed damage.

If there is any damage, REPORT TO THE CARRIER. Compu-Aire, Inc. IS NOT RESPONSIBLE FOR FILING OF ANY CLAIMS. ALL NEEDED INSPECTION AND CLAIM FILING IS THE RESPONSIBILITY OF THE RECEIVER

3. Then verify the exact voltage of the unit and compare with the voltage source. In case there is any disagreement, contact the factory.

SELECTION OF INSTALLATION SITE

Prior to installing the unit check the structure thoroughly. Ascertain the location of wiring, condensate disposal, ductwork location, ease of access to the unit for maintenance and service . **24" minimum clearance must be provided on all sides except in front of the control panel where 36" clearance is required.**

UNIT MOUNTING

Unit is shipped as a complete package with evaporator and condensing section attached together. If the unit is to be ceiling hung use 3/8" minimum diameter hanging rods for 2 thru 5 ton units and 5/8" minimum diameter hanging rods for 8 thru 12 ton units with washers, locknuts and vibration isolators. Hanger hardware is to be field supplied.

Unit must be level in order to drain condensate properly.

NOTE: Loading limitations of walls, ceilings, and/or floors must be paid particular attention to. Be sure to securely anchor the top ends of the suspension rods if the unit is to be ceiling hung. Make sure all nuts are tight. Be sure to follow all applicable codes.

PIPING CONNECTIONS

- a) Drain line for all types of unit. See "Condensate Drain" section.
- b) Humidifier water supply (1/4" size)
- c) Refrigerant Piping connections between evaporator unit and condensing unit while using air

- cooled split system option.
- d) Water Supply/Return connections for Water cooled units.
 - e) Chilled Water Supply/Return connections for Chilled Water units.

NOTE: All piping should be done in accord with “The Safety Code for Mechanical Refrigeration” and “The Code for Pressure Piping” as well as all applicable local and national codes.

Refrigerant Piping

All air cooled split systems with remote condensing unit require two refrigerant lines per Circuit – Suction Line & Liquid Line. Third line is required if optional Hot Gas Bypass is used.

All refrigeration piping should be installed with high temperature brazed. It is highly recommended that good refrigeration practices should be employed for piping supports, leak testing, dehydration, and charging of the refrigeration units. The refrigeration piping should be isolated from the building by the use of vibration isolating supports.

Take extreme care to keep refrigeration tubing clean and dry prior to installation. The following procedure should be followed.

- a) Use only refrigeration grade copper tubing, properly sealed against contamination. Water tubing often contains wax and other troublesome contaminants.
- b) Suction lines should slope $\frac{1}{2}$ inch per 10 feet towards the compressor.
- c) Suitable “P”-type oil traps should be located at the base of each suction riser to enhance oil return to the compressor.
- d) When brazing refrigerant lines, an inert gas should be passed through the line at low pressure to prevent scaling and oxidation inside the tubing. Dry nitrogen is preferred.
- e) Use only suitable silver solder alloy.
- f) Limit the soldering paste or flux to the minimum required to prevent contamination of the solder joint internally. Flux only the male portion of the connection, never the female. After brazing, remove surplus flux with a damp cloth.
- g) After all lines are connected, the entire system must be leak tested.
- h) After the final leak test, refrigerant lines exposed to high ambient conditions should be insulated to reduce heat pick-up and prevent the formation of flash gas in the liquid lines. Suction lines should be insulated, if exposed, to prevent condensation.

When installing remote condensing unit above the evaporator, the suction gas line should be trapped at the evaporator. This trap will retain refrigerant oil in the off cycle. When the unit starts, oil in the trap carried up the vertical riser and returns to the compressor.

When installing the remote condensing unit below the evaporator, the suction gas line should be trapped with an inverted trap the height of the evaporator. This prevents refrigerant migration to the compressor during off cycles.

Refrigerant Charging

Charging of the system should be carried out using visual reference to the refrigerant sight glass. Charging should be stopped when the sight glass becomes clear. Care must be taken when charging a system with refrigerant. If you are not familiar with the proper charging procedures, contact your refrigerant supplier for assistance.

Water/Glycol Piping

For water/glycol cooled units manual service shut -off valves should be installed at the supply and return line to each unit. This enables routine service and/or emergency isolation of the unit. When the condenser fluid quality is poor, filters that can be easily serviced should be placed in the supply line. These filters extend the service life of the condenser.

Chilled Water Piping

On chilled water units install manual service shut -off valves at the supply and return line of each unit. These shut-off valves are used for routine service or emergency isolation of the unit. A strainer should be installed in the system and cleaned periodically.

NOTE: Water side operating pressure not to exceed 200 PSIG

Chilled water supply and return line must be insulated. Insulating them will prevent condensation of the water supply and return lines of the unit.

LEAK TESTING

No installation is complete until the entire system has been thoroughly checked for leaks. This includes water tubing, humidifier make-up water, and condensate lines.

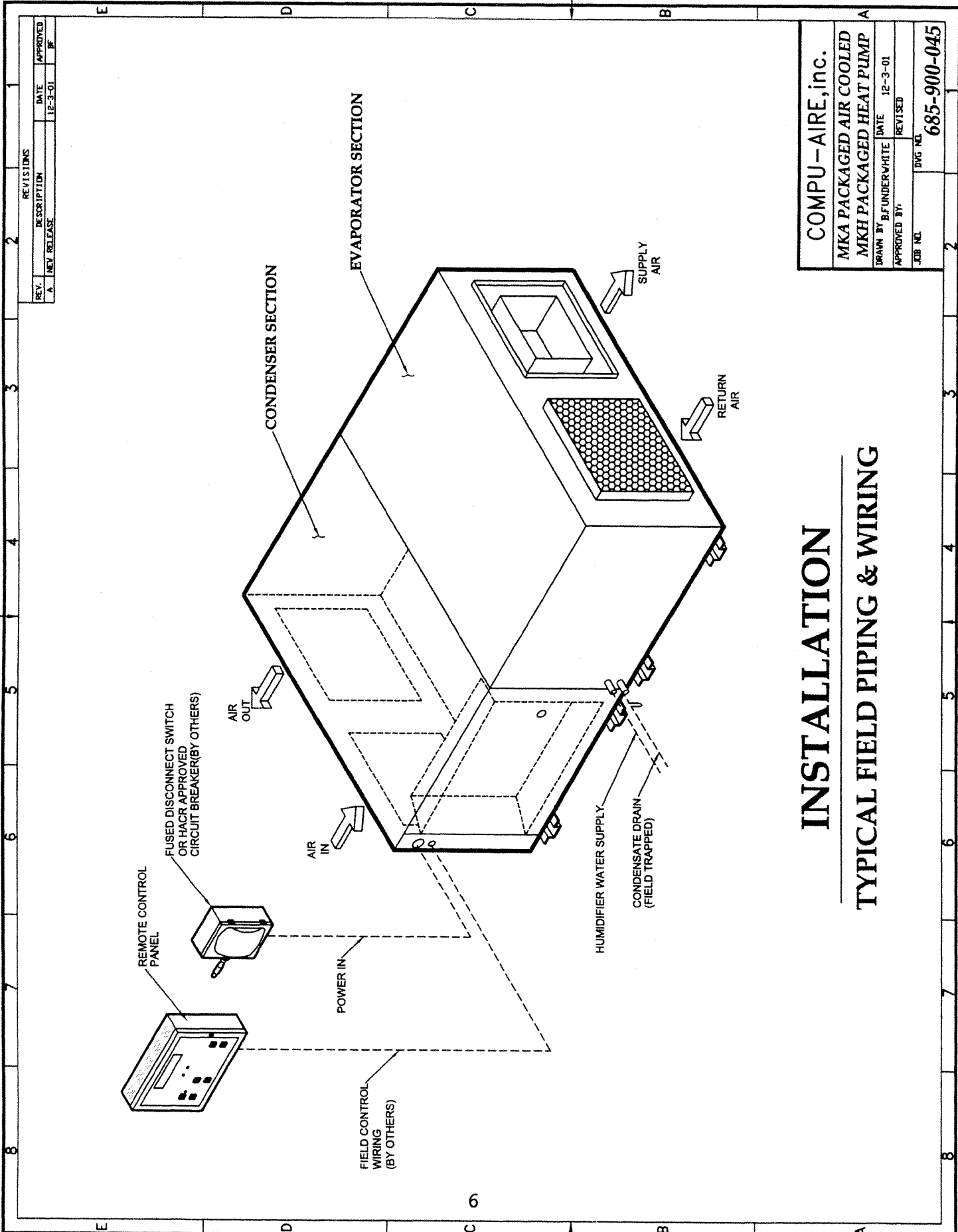

INSTALLATION

TYPICAL FIELD PIPING & WIRING

COMPU-AIRE, inc.	
MKA PACKAGED AIR COOLED MKH PACKAGED HEAT PUMP	
DRAWN BY B.FUNDERWHITE	DATE 12-3-01
APPROVED BY:	REVISED
JOB NO.	DWG NO. 685-900-045

REVISIONS		
REV.	DESCRIPTION	DATE
A	NEW RELEASE	12-3-01
		BF

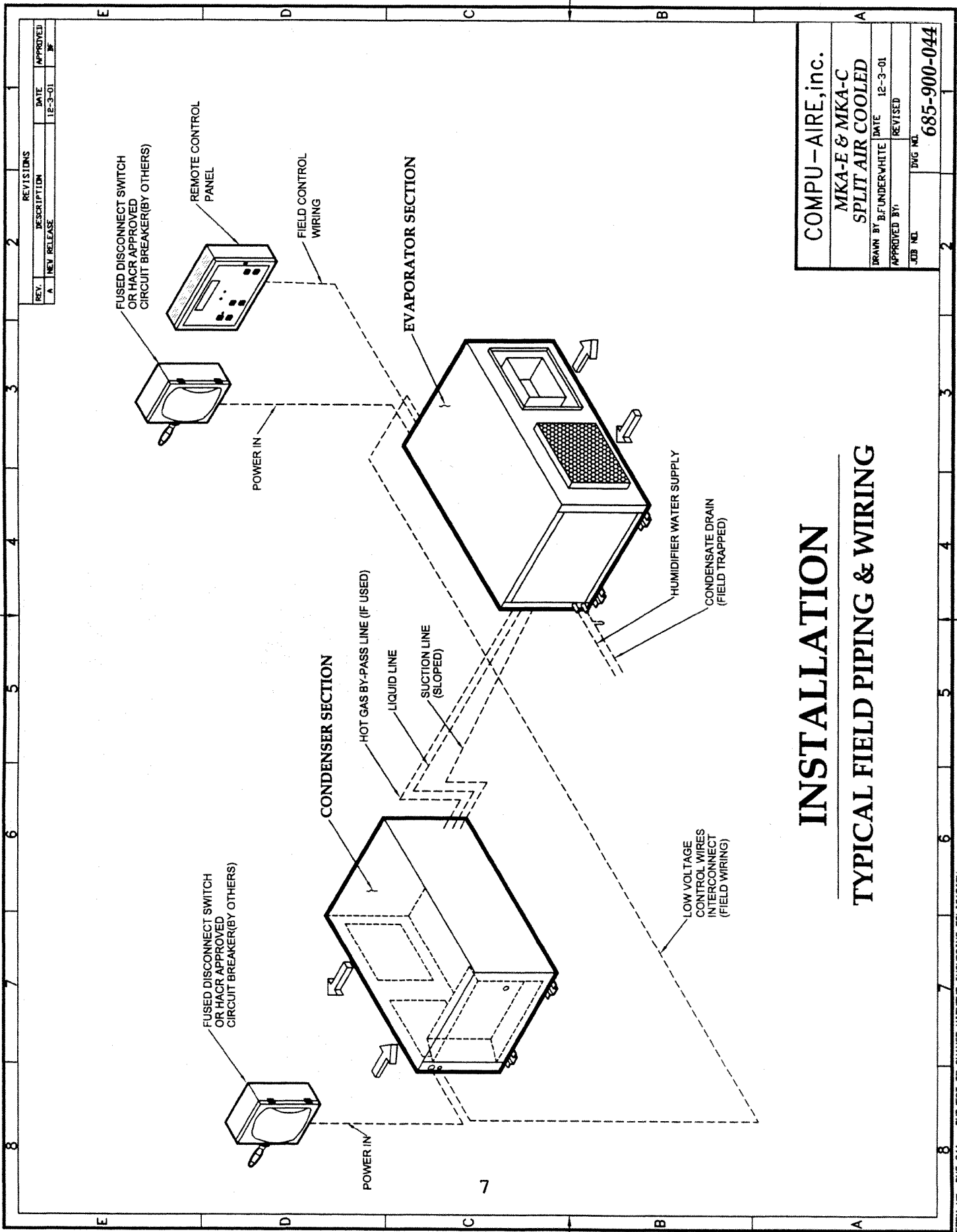

INSTALLATION

TYPICAL FIELD PIPING & WIRING

COMPU-AIRE, inc.	
MKA-E & MKA-C	
SPLIT AIR COOLED	
DRAWN BY B.FLINDERWHITE	DATE 12-3-01
APPROVED BY:	REVISED
JOB NO.	DWG NO. 685-900-044

REV. A		REV. B	
REV. A	NEW RELEASE	DATE	12-3-01
REV. B		DATE	
REV. C		DATE	

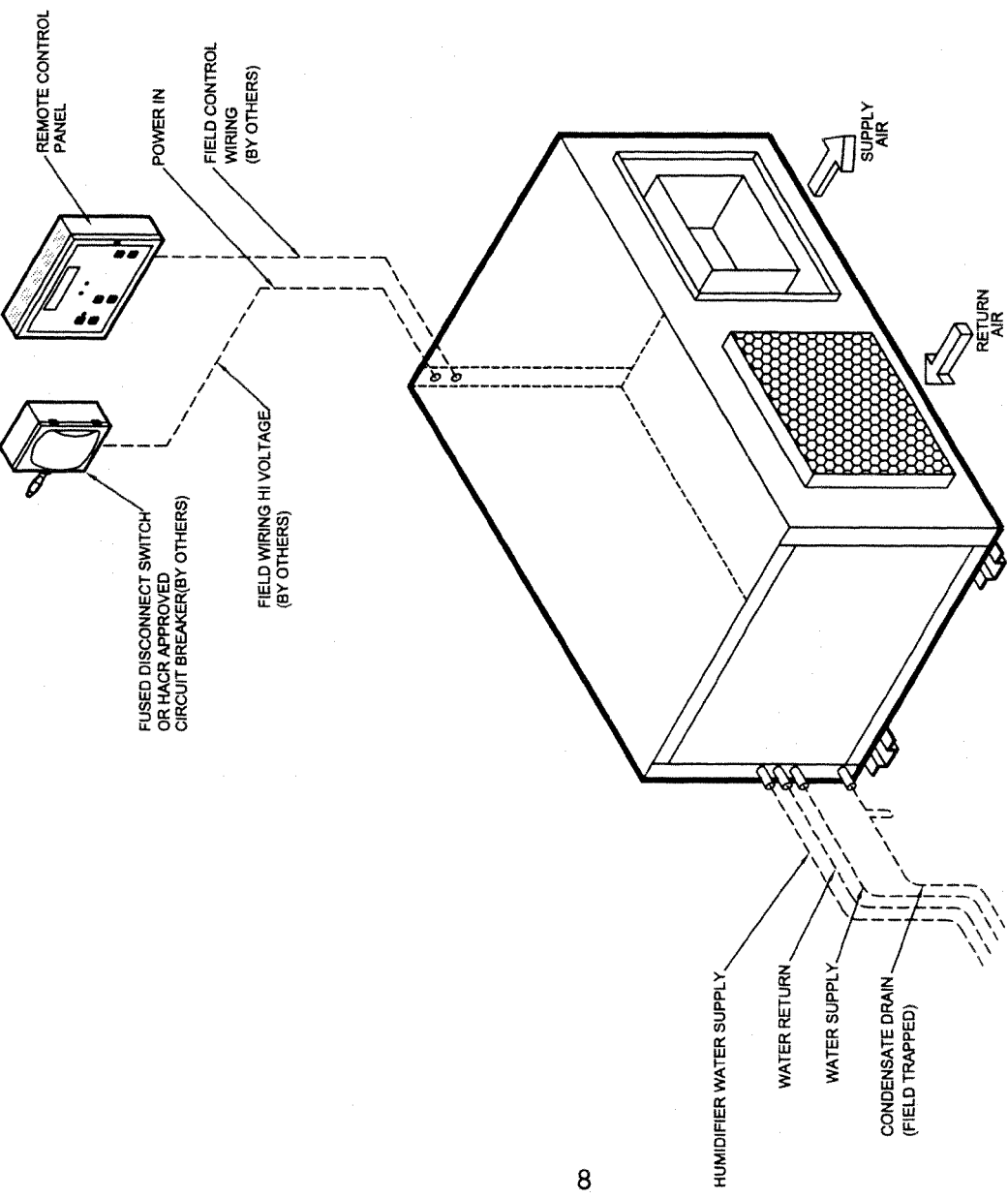

INSTALLATION

TYPICAL FIELD PIPING & WIRING

COMPU-AIRE, inc.	
MKW/MKG OR MKC	
WATER/GLYCOL COOLED	
OR CHILLED WATER	
DRAWN BY	B.FUNDERWHITE
DATE	12-3-01
APPROVED BY:	REVISER
JOB NO.	DWG NO.
	685-900-046

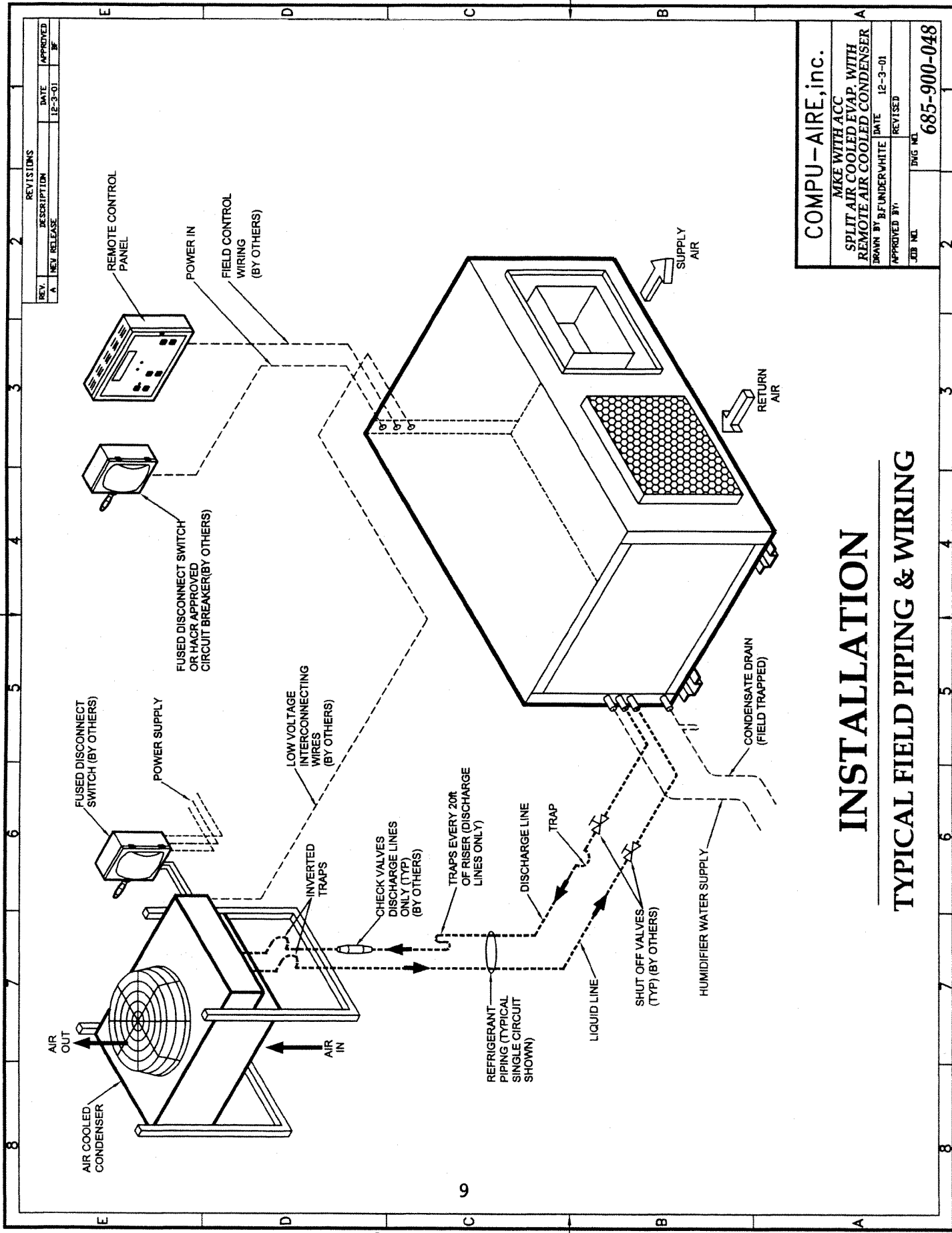

COMPU-AIRE, inc.	
MAKE WITH ACC	
SPLIT AIR COOLED EVAP. WITH	
REMOTE AIR COOLED CONDENSER	
DRAWN BY: B.F. UNDERWHITE	DATE: 12-3-01
APPROVED BY:	REVISED:
JOB NO.:	DWG. NO. 685-900-048

INSTALLATION

TYPICAL FIELD PIPING & WIRING

TYPICAL FIELD WIRING

Units are completely wired at the factory. Refer to the unit wiring diagram when making connections.

CAUTION: UNIT CONTAINS HAZARDOUS ELECTRICAL VOLTAGE. DISCONNECT POWER SUPPLY BEFORE WORKING WITHIN. LINE SIDE OF THE DISCONNECT REMAINS ENERGIZED WHEN DISCONNECT IS OFF.

Prior to any electrical hook up, check the following:

1. Verify the unit voltage, hertz and phase correspond to that specified on the unit name plate. Also, check to be sure that service provided by the utility is sufficient to handle the additional load imposed by this equipment. Refer to the unit rating plate for equipment electrical requirements.
2. Check all connections for tightness.
3. Consult and comply with all applicable local and national codes. Use copper conductors only.
4. Provide fused disconnects one each for evaporator section and one for condensing section for split units and one fused disconnect for the package unit. Provide rain-tight disconnect switch for outdoor unit.
5. Low voltage wiring must be 18 gage minimum up to 50 feet run.

The factory wiring terminates in a single control box for the self contained packaged system and has single point power connection.

Factory wiring terminates in two control boxes one each in the evaporator section and the condensing section for split system.

Remote MCP-System 2000 Control Panel must be wired (low voltage-24Vac) to the unit as per the wiring diagram.

NOTE: Use Copper wiring only. Make sure that all connections are tight.

WARNING: The unit cabinet must have an uninterrupted or unbroken electrical ground to minimize personal injury if an electrical fault should occur. It is important that an electrical ground wire of adequate size can be connected to the ground lug provided inside the control box.

DIMENSIONAL DATA 2 THRU 12 TON

- WATER COOLED • GLYCOL COOLED • CHILLED WATER SYSTEMS
- AIR COOLED SPLIT SYSTEM WHEN USED WITH REMOTE CONDENSER (MKE)

MKW, MKG
MKE, MKC

TABLE NO. 5

NOM. TONS	A	B	C	D	E	F	G	H	I	J	K	L	M
2 AND 3	45" (1143)	36" (914)	24" (610)	30" (762)	18" (457)	12" (305)	4" (102)	3" (76)	2" (51)	14" (356)	4.5" (114)	2.5" (64)	6.5" (165)
4 AND 5	52" (1321)	42" (1067)	30" (762)	36" (914)	23" (584)	18" (457)	4" (102)	3" (76)	2" (51)	18" (457)	3.5" (89)	4" (102)	3.5" (89)
8	72" (1829)	46" (1168)	30" (762)	40" (1016)	30" (762)	20" (508)	4" (102)	3" (76)	2" (51)	18" (457)	4.5" (114)	4" (102)	14" (356)
10 AND 12	80" (2032)	56" (1422)	50" (1270)	50" (1270)	30" (762)	20" (508)	4" (102)	3" (76)	2" (51)	38" (965)	4" (102)	4" (102)	20" (508)

FIGURES IN () ARE METRIC

WEIGHT LBS (APPROXIMATE)	
NOM. TONS	WATER COOLED
2	330
3	410
4	490
5	515
8	800
10	875
12	950

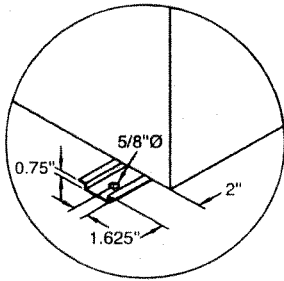

**MOUNTING RAIL
VIEW A-A
(standard on all units)**

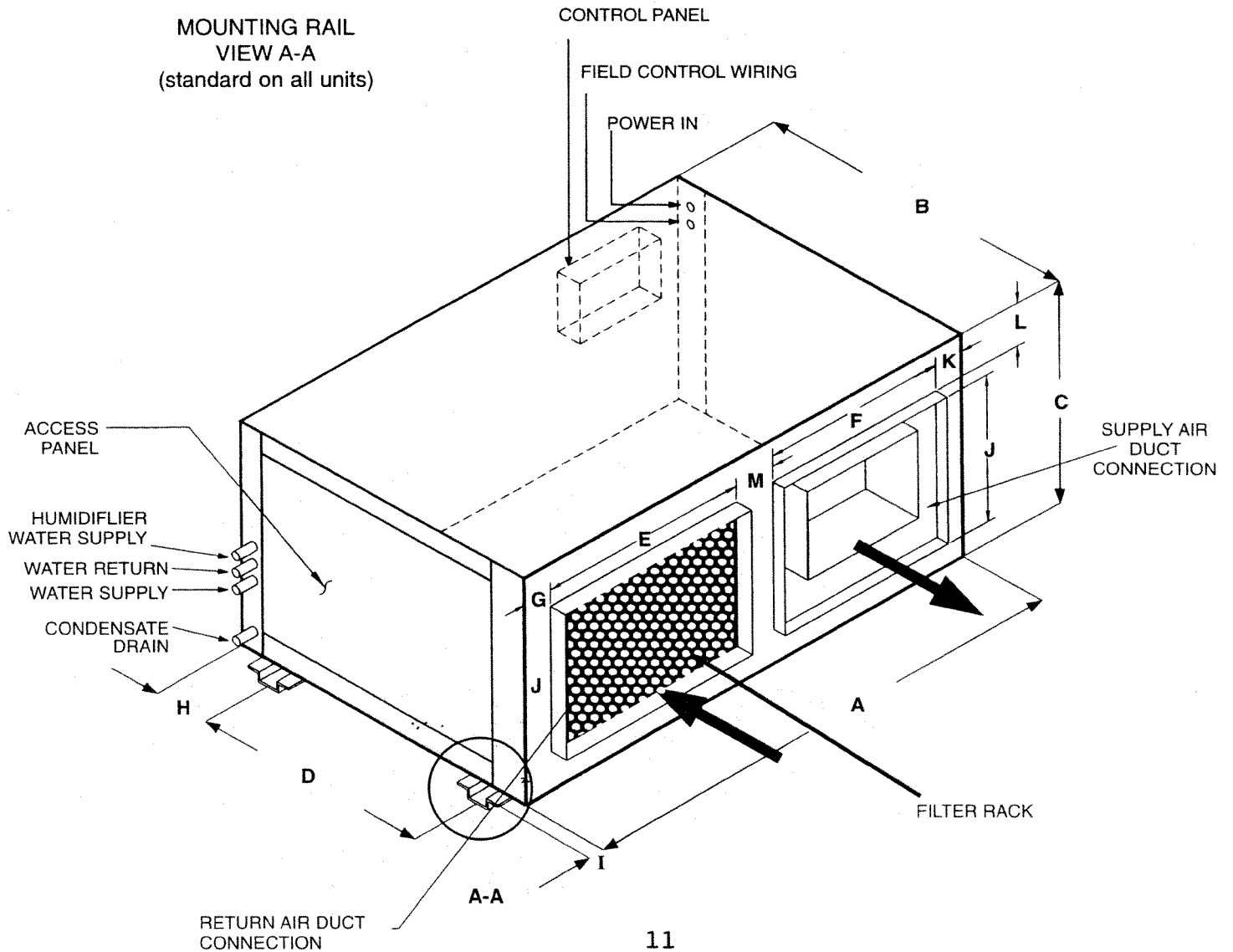

DIMENSIONAL DATA 2 THRU 12 TON AIR COOLED PACKAGED UNIT

TABLE NO. 6

NOM. TONS	A	B	C	D	E	F	G	H	J	K	L	M
2 AND 3	62" (1575)	45" (1143)	24" (610)	29" (737)	30" (762)	32" (813)	3" (76)	49" (1245)	24" (610)	26" (660)	2.5" (64)	14" (356)
4 AND 5	82" (2083)	52" (1321)	30" (762)	30" (762)	42" (1067)	40" (1016)	3" (76)	56" (1422)	36" (914)	34" (864)	4" (102)	18" (457)
8	80" (2032)	72" (1829)	30" (762)	38" (965)	40" (1016)	40" (1016)	3" (76)	76" (1930)	34" (864)	34" (864)	4" (102)	18" (457)
10 AND 12	100" (2286)	80" (2032)	50" (1270)	38" (965)	50" (1270)	50" (1270)	3" (76)	86" (2184)	44" (1118)	44" (1118)	4" (102)	38" (965)

NOM. TONS	N	P	Q	R	S	T	U	V	W	X	Y	Z
2 AND 3	12" (305)	4" (102)	18" (457)	18" (457)	1.5" (38)	16" (406)	16" (406)	2" (51)	16" (406)	16" (406)	3.5" (89)	9.5" (241)
4 AND 5	18" (457)	4" (102)	23" (584)	18" (457)	1.5" (38)	18" (457)	20" (508)	3" (76)	18" (457)	18" (457)	3.5" (89)	12.5" (318)
8	20" (508)	4" (102)	30" (762)	23" (584)	2" (51)	24" (610)	24" (610)	3" (76)	20" (508)	20" (508)	14" (356)	20" (508)
10 AND 12	22" (559)	4" (102)	30" (762)	38" (965)	4" (102)	30" (762)	40" (1016)	3" (76)	24" (610)	40" (1016)	20" (508)	16" (406)

ALL BOLD FACE DATA IN METRIC UNITS (mm)

FILTER 2" PLEATED 30%		
NOM. TONS	QTY	SIZE
2 AND 3	1	20" X 20"
4 AND 5	1	20" X 25"
8	2	16" X 25"
10 AND 12	4	16" X 20"

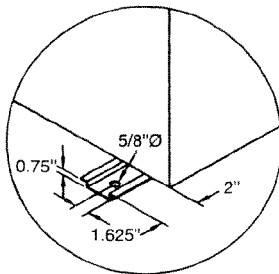

MOUNTING RAIL
VIEW A-A
(standard on all units)

WEIGHT LBS (APPROXIMATE)			
NOM. TONS	EVAP. SECTION	COND. SECTION	TOTAL
2	240	285	525
3	275	320	595
4	330	430	760
5	340	440	780
8	460	685	1145
10	485	725	1210
12	520	755	1275

Weight For MKC Is Same As That Of Evap. Section

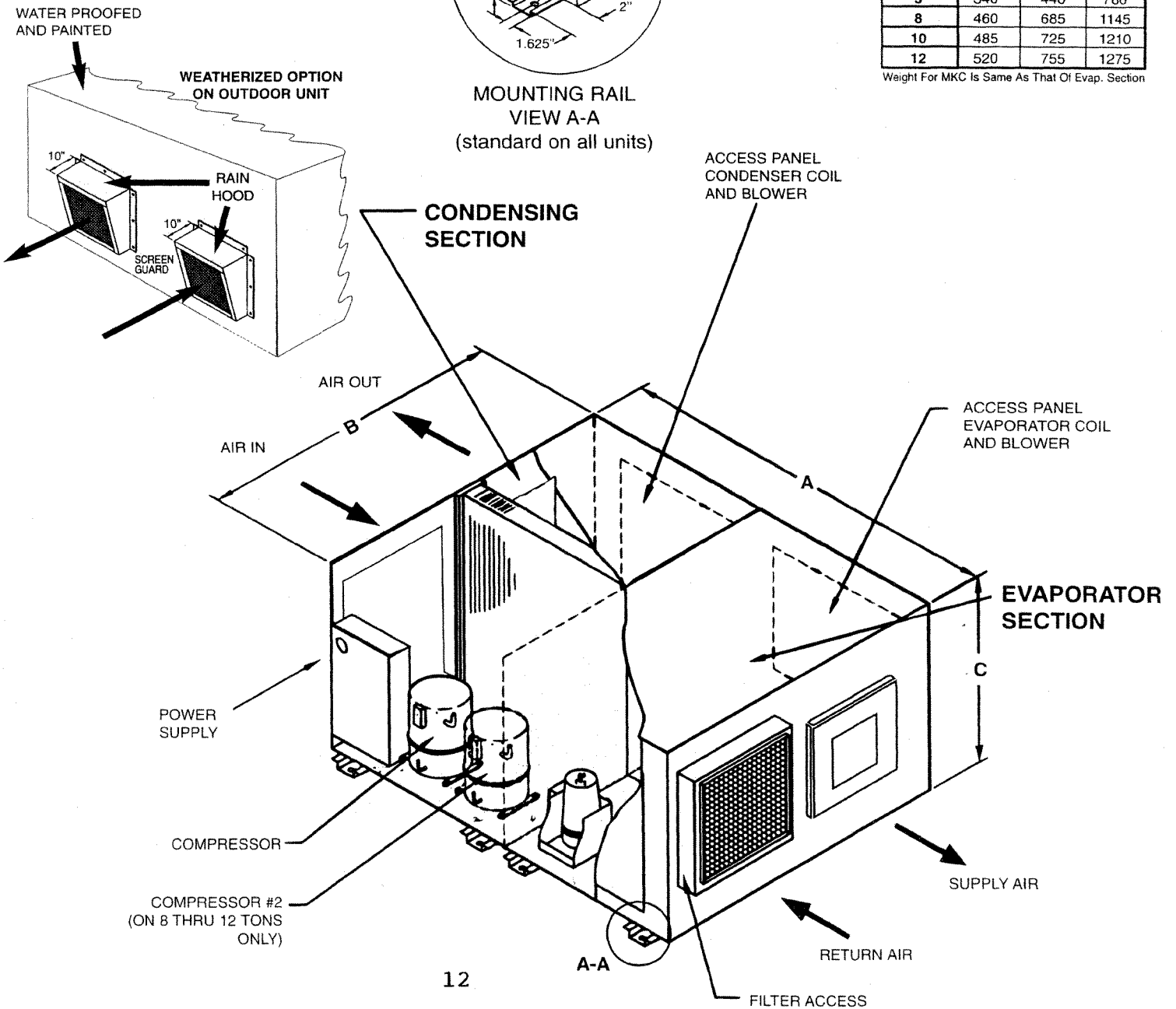

**DIMENSIONAL DETAILS FOR 2 THRU 12 TON
AIR COOLED PACKAGED UNIT**

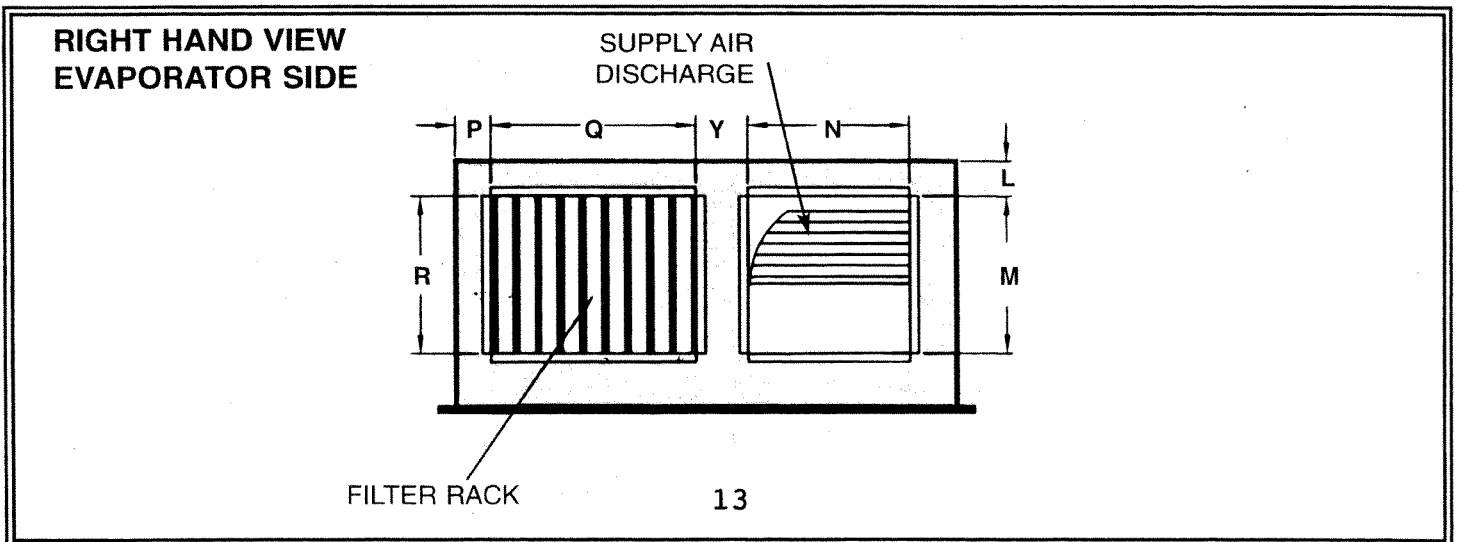
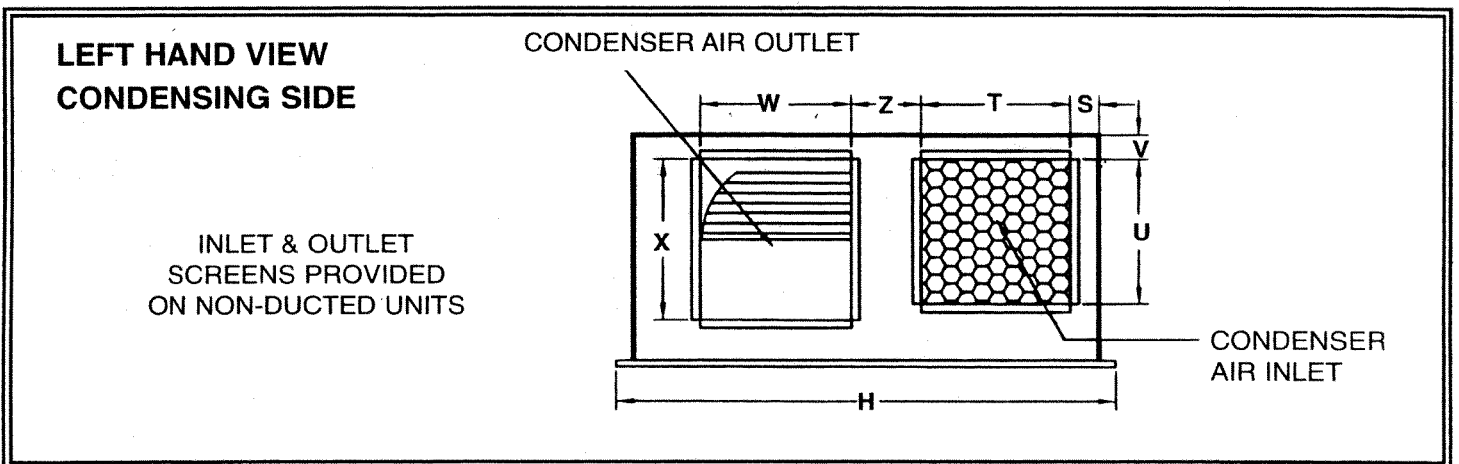
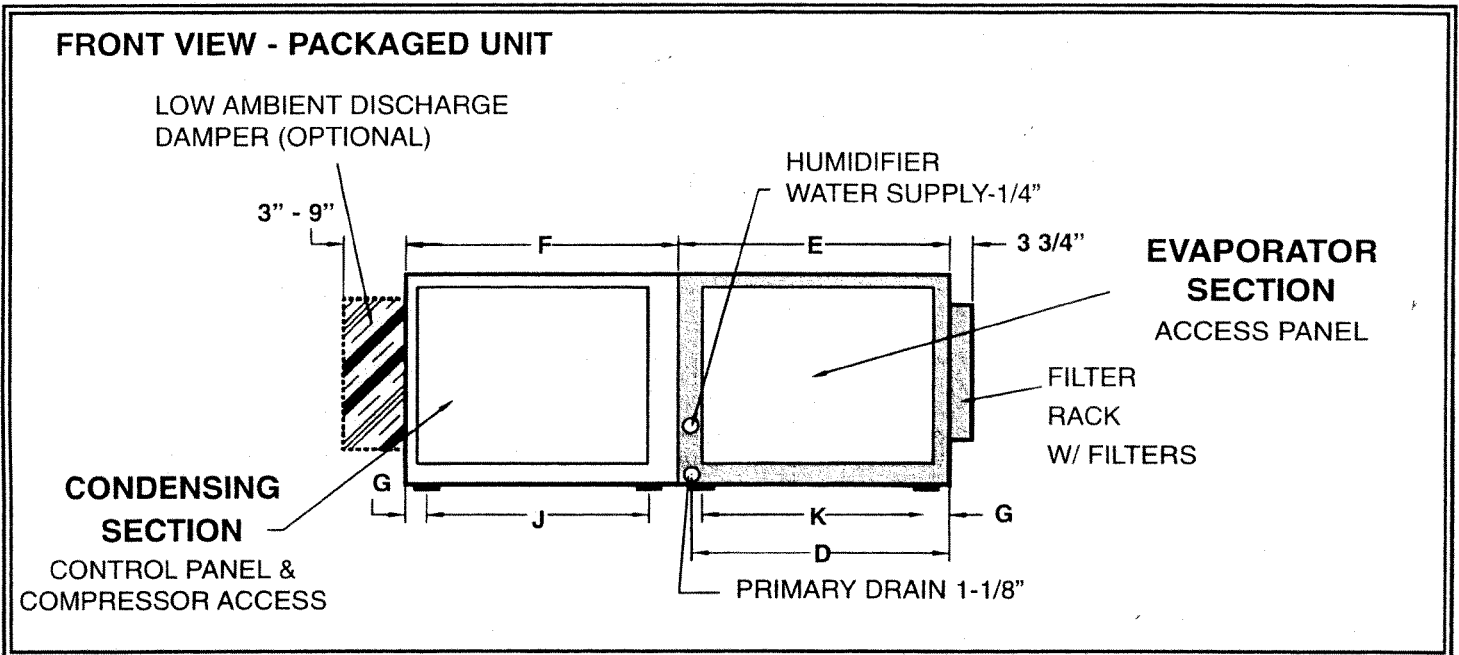

TABLE NO. 1		TECHNICAL DATA						
MKA: AIR COOLED								
NOMINAL TONS:	2	3	4	5	8	10	12	
DESCRIPTION:MODEL:MKA 208/1/60	212	312	412	512	N/A	N/A	N/A	
208-230/3/60	232	332	432	532	832	1032	1232	
460/3/60	234	334	434	534	834	1034	1234	
COOLING CAPACITY								
Entering Air 80°F DB, 67°F WB, 95°F Ambient (26.7°C DB, 19.4°C WB, 35°C Ambient)								
Total-Btu/hr (kW)	29,800 (8.7)	42,150 (12.3)	55,400 (16.2)	63,500 (18.6)	110,100 (32.2)	134,500 (39.4)	146,500 (42.9)	
Sensible-Btu/hr (kW)	22,100 (6.5)	33,720 (9.9)	46,170 (13.5)	54,100 (15.8)	97,320 (28.5)	101,950 (29.8)	115,600 (33.8)	
EER	10.2	10.2	10.3	10.1	10.2	10.3	10.1	
Entering Air 72°F DB, 60°F WB, 95°F Ambient (22.2°C DB, 15.5°C WB, 35°C Ambient)								
Total-Btu/hr (kW)	21,200 (6.2)	31,200 (9.1)	41,200 (12.1)	51,500 (15.1)	83,100 (24.3)	106,350 (31.1)	116,100 (34.0)	
Sensible-Btu/hr (kW)	17,500 (5.1)	25,800 (7.6)	36,400 (10.7)	44,500 (13.0)	75,600 (22.1)	92,500 (27.0)	105,250 (30.8)	
EVAPORATOR SECTION								
AIR FLOW DATA								
CFM - Based on 0.5" ESP (L/s)	900 (425)	1,500 (708)	2,000 (945)	2,500 (1,180)	3,350 (1,580)	4,000 (1,888)	4,800 (2,265)	
Fan Motor HP	0.75	1.0	1.0	1.5	2.0	3.0	3.0	
EVAPORATOR COIL- Copper Tubing, Aluminum Fins								
Face Area-Square Ft. (m ²)	1.75 (0.16)	3.6 (0.33)	5.0 (0.46)	5.0 (0.46)	7.5 (0.70)	12.8 (1.19)	12.8 (1.19)	
Rows	5	4	5	5	5	4	5	
CONDENSER SECTION								
AIR FLOW DATA								
CFM- Based on 0.5" ESP (L/s)	1,600 (755)	2,250 (1,062)	2,750 (1,298)	3,250 (1,535)	5,000 (2,360)	7,000 (3,300)	8,000 (3,775)	
Fan Motor HP	0.75	1.0	1.0	1.5	2.0	5.0	5.0	
CONDENSER COIL - Copper Tubing, Aluminum Fins								
Face Area-Square Ft. (m ²)	4.5 (0.42)	4.5 (0.42)	6.75 (0.63)	6.75 (0.63)	6.75 (0.63)	12.85 (1.19)	14.45 (1.34)	
Rows	4	4	5	5	6	6	6	
COMPRESSOR DATA - High Efficiency Scroll R-22								
Tonnage	2.0	3.0	4.0	5.0	4.0	5.0	6.0	
Quantity	1	1	1	1	2	2	2	
REHEAT (Electric)								
kW /Stages	7.5/1	7.5/1	7.5/1	7.5/1	15/2	15/2	15/2	
Btu/hr. Includes Fan Motor	27,522	28,160	28,160	29,433	57,245	57,245	59,793	
HUMIDIFIER-Self Generating Type with Disposable Cylinder								
kW	3.4	3.4	3.4	3.4	3.4	6.8	6.8	
Lbs/hr (kg/hr)	10 (4.5)	10 (4.5)	10 (4.5)	10 (4.5)	10 (4.5)	17.5 (8.0)	17.5 (8.0)	
PIPING DATA								
Condensate Drain-O.D.	1-1/8"	1-1/8"	1-1/8"	1-1/8"	1-1/8"	1-1/8"	1-1/8"	
*Liquid Line-O.D.	3/8"	1/2"	5/8"	5/8"	(2)5/8"	(2)5/8"	(2)5/8"	
*Suction Line-O.D.	1/2"	5/8"	7/8"	7/8"	(2)7/8"	(2)7/8"	(2)7/8"	
Humidifier Supply	1/4"	1/4"	1/4"	1/4"	1/4"	1/4"	1/4"	

BOLD FACE DATA IN METRIC UNITS

* For Split Units

TABLE NO. 2	TECHNICAL DATA						
MKW : WATER COOLED / MKG: GLYCOL COOLED							
NOMINAL TONS:	2	3	4	5	8	10	12
DESCRIPTION:MODEL:MKW/MKG 208/1/60	212	312	412	512	N/A	N/A	N/A
208-230/3/60	232	332	432	532	832	1032	1232
460/3/60	234	334	434	534	834	1034	1234
COOLING CAPACITY *							
Entering Air 80°F DB, 67°F WB (26.7°C DB, 19.4°C WB)*							
Total-Btu/hr (kW)	26,200 (7.7)	38,900 (11.4)	58,300 (17.1)	64,600 (18.9)	91,400 (26.8)	134,500 (39.4)	146,500 (42.9)
Sensible-Btu/hr (kW)	22,000 (6.4)	32,600 (9.5)	48,900 (14.3)	54,300 (15.9)	76,800 (22.6)	101,950 (29.8)	115,600 (33.8)
EER	10.4	10.9	12.8	11.2	11.1	12.4	11.4
Entering Air 72°F DB, 60°F WB (22.2°C DB, 15.5°C WB)*							
Total-Btu/hr (kW)	21,800 (6.4)	32,100 (9.4)	42,400 (12.5)	53,000 (15.6)	78,800 (23.2)	106,350 (31.1)	116,100 (34.0)
Sensible-Btu/hr (kW)	18,100 (5.3)	26,600 (7.8)	37,300 (11.0)	45,800 (13.5)	65,400 (19.2)	92,500 (27.0)	105,250 (30.8)
WATER FLOW DATA **							
GPM 85°F Entering Water (L/s)	6.0 (0.38)	9.0 (0.57)	12.0 (0.76)	15.0 (0.95)	24.0 (1.51)	30.0 (1.89)	36.0 (2.27)
Pressure Drop psig (kPa)	8.5 (58.6)	9.5 (65.5)	13.1 (90.3)	10.2 (70.3)	13.4 (92.4)	10.6 (73.1)	11.6 (80.0)
AIR FLOW DATA -							
CFM - Based on 0.5" ESP (L/s)	900 (425)	1,500 (708)	2,000 (945)	2,500 (1,180)	3,350 (1,580)	4,000 (1,888)	4,800 (2,265)
Fan Motor HP	0.75	1.0	1.0	1.5	2.0	3.0	3.0
EVAPORATOR COIL - Copper Tubing, Aluminum Fins							
Face Area-Square Ft. (m²)	1.75 (0.16)	3.6 (0.33)	5.0 (0.46)	5.0 (0.46)	7.5 (0.70)	12.8 (1.19)	12.8 (1.19)
Rows	5	4	5	5	5	4	5
COMPRESSOR DATA - High Efficiency Scroll R-22							
Tonnage	2.0	3.0	4.0	5.0	4.0	5.0	6.0
Quantity	1	1	1	1	2	2	2
REHEAT (Electric)							
kW/Stages	7.5/1	7.5/1	7.5/1	7.5/1	15/2	15/2	15/2
Btu/hr. Includes Fan Motor	27,522	28,160	28,160	29,433	57,245	57,245	59,793
HUMIDIFIER-Self Generating Type with Disposable Cylinder							
kW	3.4	3.4	3.4	3.4	3.4	6.8	6.8
Lbs/hr (kg/hr)	10 (4.5)	10 (4.5)	10 (4.5)	10 (4.5)	10 (4.5)	17.5 (8.0)	17.5 (8.0)
PIPING DATA							
Condensate Drain-O.D.	1-1/8"	1-1/8"	1-1/8"	1-1/8"	1-1/8"	1-1/8"	1-1/8"
Water Supply-O.D.	5/8"	5/8"	7/8"	7/8"	1-1/8"	1-5/8"	1-5/8"
Water Return-O.D.	5/8"	5/8"	7/8"	7/8"	1-1/8"	1-5/8"	1-5/8"
Humidifier Water Supply	1/4"	1/4"	1/4"	1/4"	1/4"	1/4"	1/4"

BOLD FACE DATA IN METRIC UNITS

*** MKG CAPACITIES : MULTIPLY WATER COOLED CAPACITIES BY 0.853 TO OBTAIN CAPACITIES FOR GLYCOL / WATER SOLUTION @ 30%**

**** CONSULT FACTORY FOR GLYCOL PRESSURE DROP, FLUID COOLER, AND PUMP SELECTIONS**

TABLE NO. 3		TECHNICAL DATA						
MKC: CHILLED WATER								
NOMINAL TONS:		2	3	4	5	8	10	12
DESCRIPTION:MODEL:MKC	208/1/60	212	312	412	512	N/A	N/A	N/A
	208-230/3/60	232	332	432	532	832	1032	1232
	460/3/60	234	334	434	534	834	1034	1234
COOLING CAPACITY								
BASED ON 45°F ENTERING WATER AND 10°F TEMPERATURE DIFFERENCE								
Entering Air 80°F DB, 67° F WB (26.7°C DB, 19.4°C WB)*								
Total-Btu/hr (kW)		25,500 (7.5)	39,800 (11.7)	52,200 (15.3)	64,700 (18.9)	93,200 (27.3)	193,719 (56.7)	224,000 (65.6)
Sensible-Btu/hr (kW)		18,300 (5.4)	32,700 (9.6)	42,300 (12.4)	53,700 (15.7)	77,400 (22.7)	128,191 (37.5)	149,876 (43.9)
Entering Air 72°F DB, 60°F WB (22.2°C DB, 15.5°C WB)*								
Total-Btu/hr (kW)		16,100 (4.7)	30,400 (8.9)	39,200 (11.5)	47,100 (13.8)	75,200 (22.0)	96,831 (28.4)	112,166 (32.8)
Sensible-Btu/hr (kW)		15,000 (4.4)	29,300 (8.6)	38,600 (11.3)	46,700 (13.7)	74,400 (21.8)	96,831 (28.4)	112,166 (32.8)
AIR FLOW DATA								
CFM - Based on 0.5" ESP (L/s)		900 (425)	1,500 (708)	2,000 (945)	2,500 (1,180)	3,350 (1,580)	4,500 (2,124)	5,400 (2,548)
Fan Motor HP		0.75	1.0	1.0	1.5	2.0	3.0	3.0
COOLING COIL DATA - Copper Tubing, Aluminum Fins								
Face Area-Square Ft. (m ²)		1.75 (0.16)	3.6 (0.33)	5.2 (0.48)	5.2 (0.48)	7.6 (0.71)	12.8 (1.19)	12.8 (1.19)
Rows		4	4	4	4	4	4	4
GPM (L/s)		4.3 (0.27)	6.5 (0.41)	8.9 (0.56)	11.1 (0.70)	16.0 (1.01)	38.5 (2.43)	44.8 (2.83)
Pressure Drop FT of Water (kPa)		16.8 (50.2)	15.4 (46.0)	14.7 (44.0)	15.5 (46.3)	17.1 (51.1)	25.1 (75.0)	37.7 (112.7)
REHEAT (Electric)								
kW /Stages		7.5/1	7.5/1	7.5/1	7.5/1	15/2	15/2	15/2
Btu/hr. Includes Fan Motor		27,522	28,160	28,160	29,433	57,245	59,793	59,793
HUMIDIFIER-Self Generating Type with Disposable Cylinder								
kW		3.4	3.4	3.4	3.4	3.4	6.8	6.8
Lbs/hr (kg/hr)		10 (4.5)	10 (4.5)	10 (4.5)	10 (4.5)	10 (4.5)	17.5 (8.0)	17.5 (8.0)
PIPING DATA								
Condensate Drain-O.D.		1-1/8"	1-1/8"	1-1/8"	1-1/8"	1-1/8"	1-1/8"	1-1/8"
Water Supply-O.D.		5/8"	5/8"	7/8"	7/8"	1-1/8"	1-5/8"	1-5/8"
Water Return-O.D.		5/8"	5/8"	7/8"	7/8"	1-1/8"	1-5/8"	1-5/8"
Humidifier Water Supply		1/4"	1/4"	1/4"	1/4"	1/4"	1/4"	1/4"

BOLD FACE DATA IN METRIC UNITS

TABLE NO. 4		ELECTRICAL DATA								
UNIT MODEL		VOLTAGE / PHASE / HERTZ								
		208-230 / 1 / 60			208-230 / 3 / 60			460 / 3 / 60		
		FLA	MCA	MFS	FLA	MCA	MFS	FLA	MCA	MFS
Air Cooled Packaged Unit Without Reheat And Humidifier										
MKA-2		24.8	28.2	40	14.5	16.6	25	7.5	8.6	15
MKA-3		31.5	36.0	50	19.4	22.3	35	9.9	11.3	15
MKA-4		40.0	46.6	70	23.0	26.8	40	12.2	14.4	25
MKA-5		50.7	58.7	90	30.7	35.5	60	15.2	17.7	30
MKA-8		N/A	N/A	N/A	45.0	48.8	60	24.0	26.2	35
MKA-10		N/A	N/A	N/A	65.8	70.6	90	32.6	34.9	40
MKA-12		N/A	N/A	N/A	68.6	73.8	100	32.6	34.9	40
Air Cooled Packaged Unit With Reheat And Humidifier										
MKA-2		60.9	73.3	90	35.3	42.6	50	16.9	20.4	25
MKA-3		67.6	81.0	100	40.2	48.3	60	19.7	23.8	30
MKA-4		76.1	91.7	125	43.8	52.8	70	21.6	26.1	35
MKA-5		86.8	103.8	150	51.5	61.5	80	24.6	29.5	40
MKA-8		N/A	N/A	N/A	71.7	85.9	100	34.2	41.1	50
MKA-10		N/A	N/A	N/A	88.2	103.5	125	41.8	48.4	60
MKA-12		N/A	N/A	N/A	89.6	105.2	125	41.8	48.4	60

TABLE NO. 4 Continued

ELECTRICAL DATA

UNIT MODEL	VOLTAGE / PHASE / HERTZ								
	208-230 / 1 / 60			208-230 / 3 / 60			460 / 3 / 60		
	FLA	MCA	MFS	FLA	MCA	MFS	FLA	MCA	MFS
Air Cooled Split Unit - Evaporator Section									
Without Reheat And Humidifier									
MKA-2 (E)	5.6	7.0	15	3.0	3.8	15	1.5	1.9	15
MKA-3 (E)	6.8	8.5	15	3.9	4.9	15	1.8	2.3	15
MKA-4 (E)	6.8	8.5	15	3.9	4.9	15	1.8	2.3	15
MKA-5 (E)	9.3	11.6	20	5.7	7.1	15	2.4	3.0	15
MKA-8 (E)	N/A	N/A	N/A	7.5	9.4	15	3.4	4.3	15
MKA-10 (E)	N/A	N/A	N/A	10.5	13.1	20	4.8	6.0	15
MKA-12 (E)	N/A	N/A	N/A	10.5	13.1	20	4.8	6.0	15
Air Cooled Split Unit - Evaporator Section									
With Reheat And Humidifier									
MKA-2 (E)	41.7	52.1	60	23.8	29.8	30	10.9	13.6	15
MKA-3 (E)	42.8	53.5	60	24.7	30.9	35	11.2	14.0	15
MKA-4 (E)	42.8	53.5	60	24.7	30.9	35	11.2	14.0	15
MKA-5 (E)	45.4	56.7	60	26.5	33.1	40	11.8	14.8	20
MKA-8 (E)	N/A	N/A	N/A	49.2	61.5	70	22.2	27.8	30
MKA-10 (E)	N/A	N/A	N/A	52.2	65.2	70	23.6	29.5	30
MKA-12 (E)	N/A	N/A	N/A	52.2	65.2	70	23.6	29.5	30
Air Cooled Split Unit - Condensing Section									
MKA-2 (C)	19.2	22.6	35	11.5	13.6	20	6.0	7.1	15
MKA-3 (C)	24.7	29.2	45	15.4	18.3	30	8.5	10.2	15
MKA-4 (C)	33.2	39.8	70	19.0	22.8	40	10.4	12.6	20
MKA-5 (C)	41.4	49.4	80	25.0	29.8	50	12.6	15.1	25
MKA-8 (C)	N/A	N/A	N/A	37.5	41.3	60	20.6	22.8	30
MKA-10 (C)	N/A	N/A	N/A	55.3	60.1	80	27.6	30.1	40
MKA-12 (C)	N/A	N/A	N/A	59.1	63.3	90	27.6	30.1	40
Water Cooled Unit									
Without Reheat And Humidifier									
MKW-2	19.2	22.6	35	11.5	13.6	20	3.0	7.1	15
MKW-3	24.7	29.2	45	15.4	18.3	30	8.5	10.2	15
MKW-4	33.2	39.8	70	19.0	22.8	40	10.4	12.6	20
MKW-5	41.4	49.4	80	25.0	29.8	50	12.6	15.1	25
MKW-8	N/A	N/A	N/A	37.5	41.3	60	19.8	21.9	30
MKW-10	N/A	N/A	N/A	49.1	53.9	70	24.8	27.3	40
MKW-12	N/A	N/A	N/A	51.9	57.1	80	24.8	27.3	40
Water Cooled Unit									
With Reheat And Humidifier									
MKW-2	55.3	67.7	80	32.3	39.6	50	15.4	18.9	25
MKW-3	60.8	74.2	90	36.2	44.3	60	17.9	21.9	30
MKW-4	69.3	84.9	110	39.8	48.8	70	19.8	24.3	35
MKW-5	77.5	94.5	125	45.8	55.5	80	22.0	26.9	35
MKW-8	N/A	N/A	N/A	64.2	78.4	90	30.4	37.2	45
MKW-10	N/A	N/A	N/A	71.5	86.8	110	33.6	40.8	50
MKW-12	N/A	N/A	N/A	72.9	88.5	110	33.6	40.8	50
Chilled Water Unit									
Without Reheat And Humidifier									
MKC-2	5.6	7.0	15	3.0	3.8	15	1.5	1.9	15
MKC-3	6.8	8.5	15	3.9	4.9	15	1.8	2.3	15
MKC-4	6.8	8.5	15	3.9	4.9	15	1.8	2.3	15
MKC-5	9.3	11.6	20	5.7	7.1	15	2.4	3.0	15
MKC-8	N/A	N/A	N/A	7.5	9.4	15	3.4	4.3	15
MKC-10	N/A	N/A	N/A	10.5	13.1	20	4.8	6.0	15
MKC-12	N/A	N/A	N/A	10.5	13.1	20	4.8	6.0	15
Chilled Water Unit									
With Reheat And Humidifier									
MKC-2	41.7	52.1	60	23.8	29.8	30	10.9	13.6	15
MKC-3	42.8	53.5	60	24.7	30.9	35	11.2	14.0	15
MKC-4	42.8	53.5	60	24.7	30.9	35	11.2	14.0	15
MKC-5	45.4	56.7	60	26.5	33.1	40	11.8	14.8	20
MKC-8	N/A	N/A	N/A	49.2	61.5	70	22.2	27.8	30
MKC-10	N/A	N/A	N/A	52.2	65.2	70	23.6	29.5	30
MKC-12	N/A	N/A	N/A	52.2	65.2	70	23.6	29.5	30

FLA : Full Load Amps
MCA : Minimum Circuit Ampacity
MFS : Maximum Fuse Size

WIRING DIAGRAMS: PLEASE REFER THE SEPARATE FILE.

CONDENSATE DRAIN

Evaporator and the condensing sections (air cooled only) are provided with individual condensate drains, 3/4" stub. Hook both drains with "P" traps. Provide 1/4" slope per 10 feet.

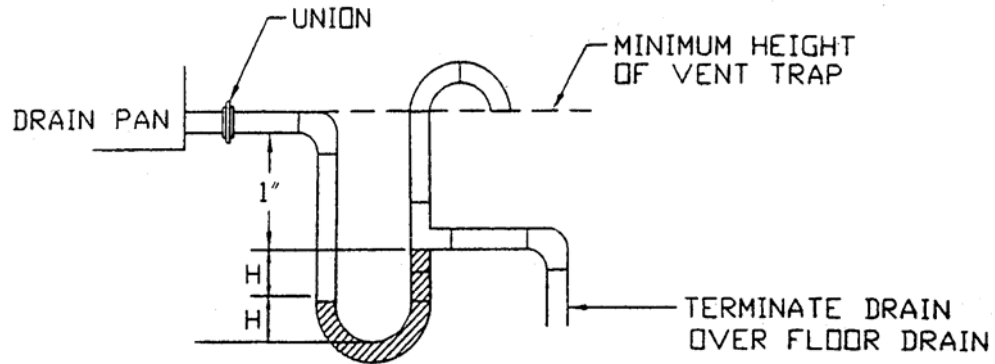

BLOW-THRU UNIT

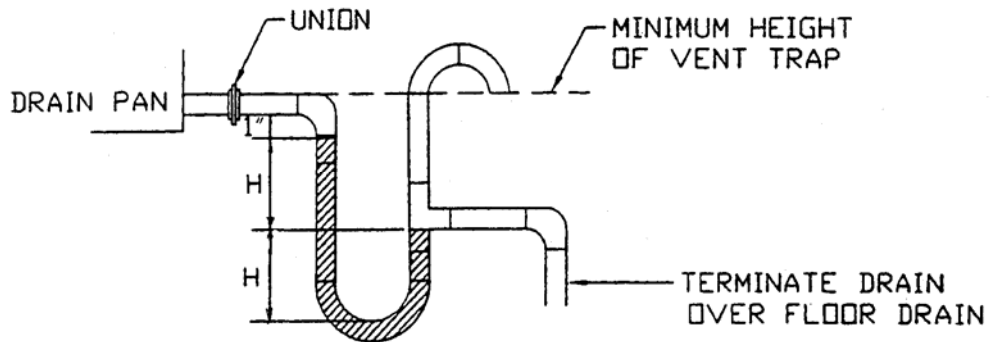

DRAW-THRU UNIT

NOTE: 'H' EQUALS THE NEGATIVE ESP ON DRAW-THRU UNITS
'H' EQUALS THE TSP ON BLOW-THRU UNITS

CAUTION: Drain line contains boiling water from humidifier. Use copper or other suitable material for the drain.

NOTE: COMPU-AIRE HIGHLY RECOMMENDES AN AUXILIARY DRAIN PAN TO BE PROVIDED UNDER THE UNIT. (TO BE FIELD FURNISHED AND INSTALLED BY OTHERS)

AIR FLOW

The evaporator and the condensing sections are provided with variable pitch motor pulley which are field adjustable. Refer to the specification data for the air flow data. In case field adjustments are made, check to verify the motor full load amps.

LOW AMBIENT CONTROLS

(A) Fan Cycling Control (Standard):

A standard Maxi-Kool Air Cooled unit is provided with a Fan Cycling (On/Off) control on condenser fan. The Fan Cycling Control provides mild ambient down to 50 ° F.

(B) Low Ambient Damper Control (Optional):

Locations where the AIR COOLED unit is needed to operate below 50°F. A low ambient damper control is provided at condenser fan discharge. The damper control can be effective down to 0 ° F.

(C) Head Pressure Control (Optional) - Low ambient Control Below -20°F

This type of low ambient control includes head pressure control valves and the receiver package. The head pressure control valve is factory installed on the condensing coil. The receivers are also mounted inside the unit.

Operation of Head Pressure Control Valve:

During periods of low ambient temperatures the condensing temperature falls until it approaches the setting of the head pressure control valve, which throttles towards a closed setting, thus restricting the flow of the liquid from the condenser. This causes the refrigerant to back up in the condenser and reduces the effective condenser surface. The check valve opens after the head pressure control has offered enough restriction and then causes the differential between the condensing pressure and the receiver pressure to exceed 20 psig. The hot gas flowing through the check valve serves to heat the cold liquid being passed by the limitizer valve. Thus, the liquid reaches the receiver warm and with sufficient pressure to assure proper expansion valve operation. The check valve and limitizer valves modulate the flow automatically to maintain proper condensing pressures.

STEAM GENERATING HUMIDIFIER

PRINCIPLE OF OPERATION:

When the humidistat calls, the cylinder fills to 110% of the Full Load Amperage (F.L.A.) or to the top of the cylinder, whichever comes first.

If it reaches 110% F.L.A. the water heats and boils away to a level giving only 90% F.L.A.

An electronic timer uses the rate of fall to determine the water level. The objective is to concentrate current-carrying minerals in the cylinder so that a smaller volume of water is required to produce the rated steam output.

This achieve the longest life for the disposable cylinder because of minimum electrode coverage and uses less energy because the high concentration allows minimal d rain rate.

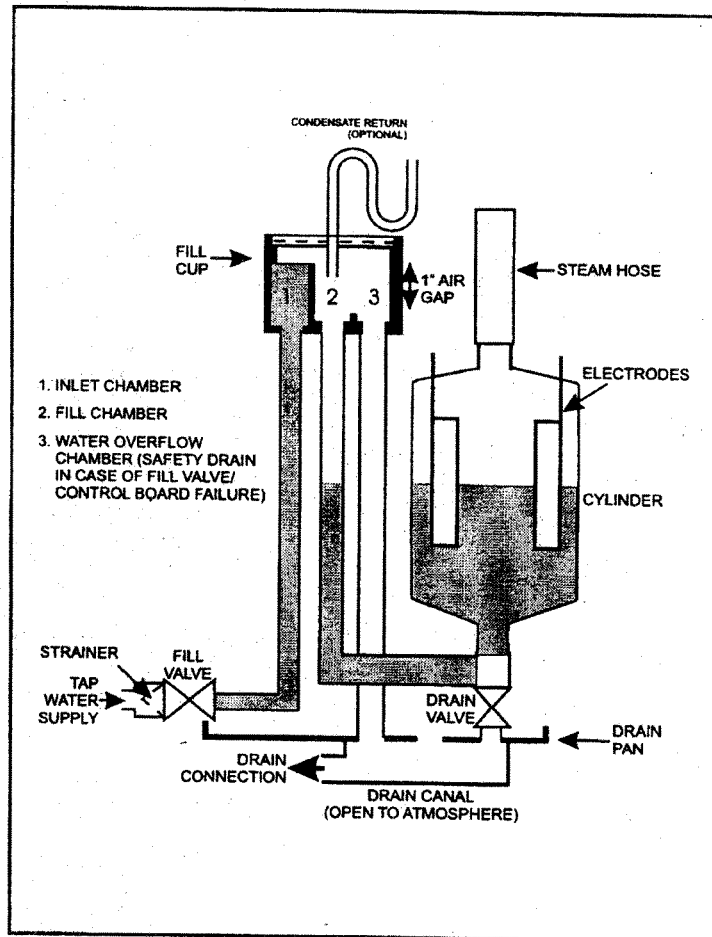

When it reaches 90% F.L.A. the fill valve will open refilling cylinder to 110% FLA. On occasion, the drain valve will also come on if water level is too high a concentration and the requirement for a dilution of the water in the cylinder.

If the water reaches top of cylinder before 110% F.L.A. the fill valve shuts off via the sensor and fill -boil- fill-boil cycle continues, cycling off the red full cylinder light until the concentration becomes high enough to reach 100% F.L.A. Then the following described control process takes over.

WATER SUPPLY AND PLUMBING

- 1) The orifice in the fill valve(s) is sized for an extended water pressure range of 30 to 85 psi.
- 2) For water pressure between 15 and 30 psi, notify the factory and the next larger size of fill valve will be supplied.

- 3) For cases below 15 psi, notify the factory and fill valve with largely oversized orifice will be supplied.
- 4) For cases above 85 psi, install a pressure reducing valve in the water feed line to the unit. Otherwise insufficient cylinder water will drain when fill and drain mix during the automatic dilution cycle.
- 5) With extremely dirty or muddy water sources, e.g. some well sources, ensure proper filtration by adding an external filter to the water line entering the unit. (Consult factory for accessories such as filters).
- 6) DO NOT soften water with this humidifier unit because it is much too conductive.
- 7) DO NOT use completely demineralized water with this humidifier unit as it is the minerals that allow the electrode principle to work.
- 8) DO NOT use a hot water source as it will cause deposits to eventually block the fill valve orifice.

Water Connection

- 1) A copper compression olive type coupling for 1/4" soft copper tubing is provided with unit and requires no soldering for the water connection to the unit.
- 2) An isolating gate valve should ALWAYS be placed in feed water line allowing service of the fill valve.

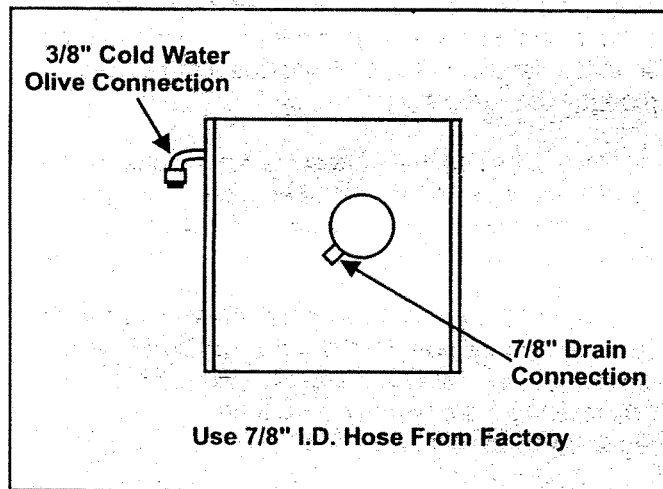

Bottom view of MES-U unit

- 3) Each unit is fitted with a fill solenoid valve located on the base drain pan. Flow orifices are designed for water pressures from 30 -85 psi and are protected by the built-in strainer.
- 4) For inlet water pressure outside this range, the factory should be contacted. (See also water supply section)

HUMIDIFIER START-UP:

Check to see that the unit is securely mounted on a level surface with the proper drain and water supply. Check for correct voltage with appropriately sized service. Check that the steam distributor, steam supply hose and condensate line are correctly installed and routed back to the unit. Ensure that the external control humidistat is located in an area to properly sense the relative humidity to be maintained by the humidifier, and that the inter-connecting low voltage wires between the humidistat and unit's control terminal strip are in accordance with the wiring diagram.

Check **all electrical connections** for wires which may have become **loose in shipping**. Components burnt due to loose connection are NOT under warranty.

Check electrode plugs to ensure they are pressed firmly onto the electrode pins .

Important: Loose connections will cause overheating of the cylinder plugs and probably melting of the plugs and/or cylinder.

Open the isolating gate valve in the feed water line to the unit.

Make sure the humidistat is set high enough to call for humidification.

Turn on the main disconnect in the primary service feeding the unit and check that unit has power at the primary terminal block.

“PUSH THE AUTO ON/OFF/DRAIN SWITCH TO “ON””.

Water will start to enter the cylinder through its bottom port and rise in the cylinder to a point determined by the solid state control circuitry.

It is not unusual upon initial start-up for the water to fill the cylinder an cycle on the red high water sensor light.

The red light simply acts as a safety to shut off the fill valve and prevent over fitting. With the red light on, the water in the cylinder will continue to heat and after a few minutes start to boil. After the boiling action of the water has lowered the water level below the sensor at the top of the cylinder, the red light will go out and the fill solenoid will again open until the cylinder is again full.

This cycling of the red light and fill valve will continue until the unit's full output capacity is reached after which the water level will automatically lower itself in the cylinder. (The increased concentration allows for lower electrode coverage while maintaining the same output). When a stabilized condition is reached the water will be boiling close to the cylinder seam level. The solid state circuitry will maintain the proper concentration in the cylinder by introducing short drains only when necessary.

If the cylinder is manually drained, the above process will repeat itself.

LOW WATER CONDUCTIVITY

Should normalization of the unit be required immediately after start-up, the installer may speed up the process by artificially increasing water conductivity. The installer should dissolve half a teaspoon of table salt (no more) in a cup of water and add it to the cylinder by means of the fill cup attached to the plumbing section.

Open the plumbing compartment and add salt solution through cylinder outlet. Excessive amounts of salt will result in erratic operation of the unit, however, normalization of the unit will occur automatically through the solid-state control sequence.

CAPACITY ADJUSTMENT

The M.E.S. series of humidifiers are factory set to cover most normal conditions. If an extreme situation is encountered notify the factory for instructions.

CYLINDER REPLACEMENT

After an extended period of operation in accordance with life expectancy information, the cylinder is completely used as indicated by a red light illuminated on the face of the cabinet. When this condition is reached, a new replacement cylinder is to be installed.

NOTE: Red light may come on during initial start -up but does not mean cylinder replacement.
See "Humidifier Start-up" Section

Consult factory or agent for replacement. Quote the cylinder model from the white 3 -digit label on the cylinder or quote model, voltage and serial number from unit specification label.

When to replace the stem cylinder:

The steam cylinder is disposable and must be replaced at the end of cylinder life. Cylinder life is dependent on water supply conditions and humidifier usage. Failure to replace the cylinder at the end of cylinder life may result in unit damage.

Extended Shutdown:

Any time that the unit is going to be shut down for an extended period of time, including summer shutdown, **ALWAYS drain** down the cylinder before disconnecting power. Otherwise, the electrodes are subject to harmful corrosion which drastically shortens the cylinder life. Do not leave the switch in the DRAIN position indefinitely as the drain coil could burn out. Leave the switch in the OFF position and

REMOVING THE CYLINDER

- 1) Turn off the water supply to the unit
- 2) The old cylinder must be drained completely before removing. This is done by pushing the auto on/off drain switch to the "drain" position.
- 3) When completely drained, push the auto/on/off drain switch to the "off" position.
- 4) Open the main disconnect during the entire cylinder change operation.
- 5) The power wires to the cylinder are attached by cylinder plugs to the electrode pins on top of the cylinder. Pull these plugs vertically off the pins.
- 6) Using slot screw driver, loosen the steam hose clamp(s) and pull steam hose off vertically.

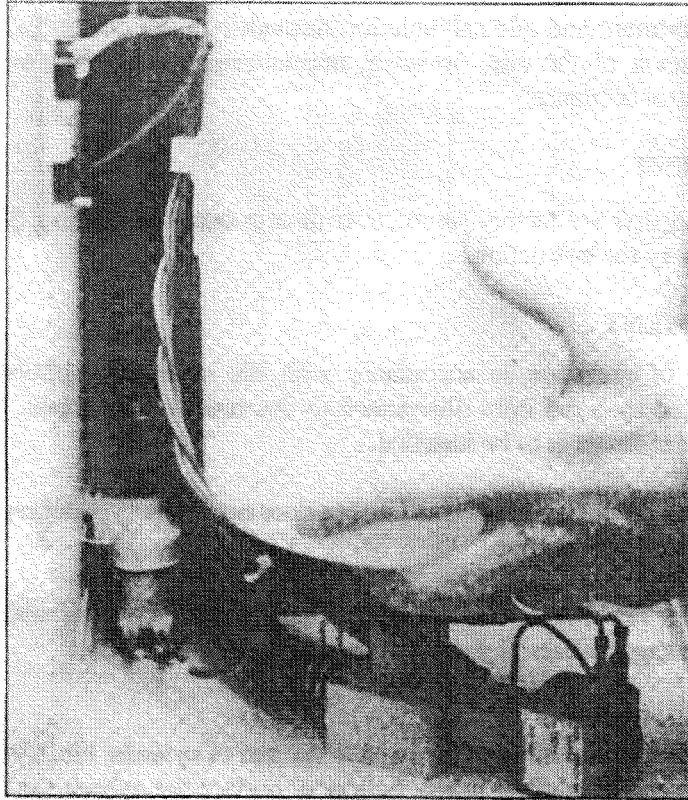

Cylinder Removal

- 7) The cylinder is now ready to be lifted out of the unit.

INSTALLING THE NEW CYLINDER

- 1) The reverse procedure should be followed to install a new cylinder. The main disconnect is to be left open until the cylinder is completely installed and reconnected.
- 2) Ensure that the cylinder mounting stubs are seated properly in the allotted side mounting slots within the unit.
- 3) The white cylinder plug on all units is for the sensor electrode which always goes on the single pin offset from the others.
- 4) Ensure that cylinder plugs are very snug on the pins.

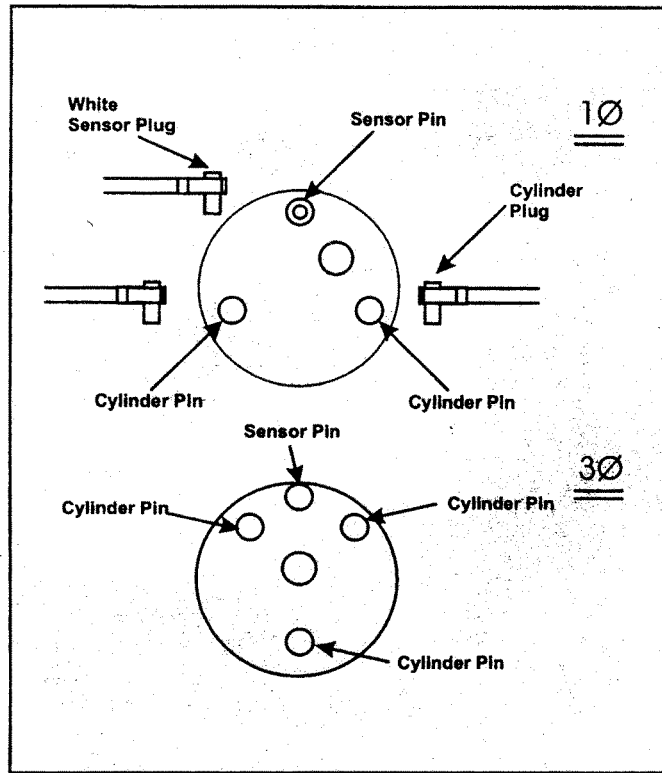

Cylinder Plugs

- 5) For loose fitting plugs, a temporary solution is to squeeze plugs with a pair of pliers before installing. Since loose plugs may generate enough heat to melt and destroy the plug and cylinder new plugs must be ordered.

TROUBLE-SHOOTING HUMIDIFIER

Auto on/off/drain switch in "on" position -unit will not fill:

When the on/off control circuit is made and the "auto on/off/drain" switch is pushed to "on", the 24 volt holding coil of the primary contactor should energize. The resulting magnetic pull closes the high voltage contacts with a distinct and audible "clunk". If the contactor will not make, then inspect the following while referring to the wiring diagram.

- 1) Check for 24VAC across pins 18 and 26.
- 2) Jumper the humidistat on external control terminal strip. If contactor operates then control system is at fault.
- 3) The low voltage 3 amp fuse located in the control box could be blown.
- 4) The contactor holding coil could be open or shorted.
- 5) The switch could be defective.

Recheck that the "auto/on/off drain" switch is still at "on". If it is, then shut off the main disconnect and

check fuses or breaker of the main disconnect. If they are serviceable, turn power back on.

To test for a defective "auto/on/off drain" switch, connect a wire from the fuse directly to terminal 6 on the external control strip. If the contactor activates, the "on" side of the switch is defective. If the contactor does not activate, then the basic unit p.c. board could be defective.

If the 3 amp control fuse blows when the wire from the fuse touches terminal 6 on the external controls strip, contactor holding coil could be shorted. Replace the contactor if necessary.

Return wires to normal.

After the necessary components have been replaced and the contactors pull in, there is high voltage to the cylinder and the control sequence can begin.

Approximately 30 seconds after the contactor pulls in, the fill valve coil should energize. There is also a visible fill relay on the basic printed circuit board. It is the one located farthest from the C.T. core. The points on this relay must be touching in order for the fill valve could be energized.

If the points will not touch after the built-in time delay, then the sensor input may be interfering. To confirm, remove the red and black sensor wires from the terminal 6 and 10 on the PC board. Wait 30 seconds and if the fill relay point now touch, then sensor should be replaced. If they do not touch, then the PC board could be faulty. To confirm, disconnect the red wire from terminal 18 and touch it to terminal 14. If the fill valve coil activates then the basic PC board should be replaced. If it still does not activate then the fill valve coil should be replaced.

Having changed the necessary components, water starts filling the cylinder and begins to submerge the electrodes. Because of the high voltage across the electrodes, the water can now conduct electricity.

Red "Change Cylinder" light on - Water at top of cylinder:

- Common occurrence on start-up - See "Humidifier start up and Operation" section.
- If cylinder is old, it indicates replacement time (can be ordered from factory). See "When to replace steam cylinder" section..

Red "Change Cylinder" light on - water NOT at top of cylinder:

- Water foaming to top of cylinder to activate red light, also may be accompanied by arcing (flashing) inside cylinder

Water remains at high level and won't concentrate:

- Normal on cold start-up, can be accelerated by adding maximum 1 tsp. of salt to the cylinder (thorough the plastic fill cup) on fill cycle. "See Low Water Conductivity" section.
- If the unit has been operating extensively, observe for normal fill -boil-fill-boil cycle; no drain should be occurring. Check for leaking drain valve or back pressure.

Water beyond top of cylinder up into spout:

- Red light not on and fill still activated; jumper across connection of sensor on basic unit PC board, if fill remains on when connection is jumped, then basic PC board is faulty.

- If fill shuts off, then verify primary voltage to cylinder (contactor energized). If primary voltage is present, the high water sensor PCB is defective.

Unit drains continually:

- May be caused by foaming and/or back pressure, or leaking drain valve.
- Cylinder is almost empty, check for magnetic pull on drain solenoid indicating miswiring. If no pull, drain actuator is blocked open, remove, disassemble and clean.
- If drain is occurring through activated drain valve, valve is miswired or electronics are faulty – consult factory.
- If drain is occurring through the overflow on the fill cup, this is due to abnormal restriction on the steam line and back pressure forces water out of the cylinder, therefore, water cannot concentrate and level must stay high, review installation of steam line to ensure no blockages or excessive static pressure in air system.

START-UP

PHASE I

1. Check all electrical connections for tightness.
2. Check belt tension.
3. Check pulley and motor screws for tightness.
4. Check supply voltage on all three phases. A variance of more than 10% from the nameplate rating cannot be tolerated.
5. Check auxiliary equipment wiring: remote condensers, pump, etc.
6. Check to see that the air filter is installed.
7. Turn unit on and check for proper blower motor rotation.
8. Turn unit off.
9. Be sure the humidifier is filled with water.

PHASE II

1. With the unit off, set the temperature set point at high.
2. The air cooled split unit can be charged at this time. Liquid refrigerant can be put into the high side at the receiver only. Once the receiver and refrigerant container pressures have equalized, continue the charging process at the low side of the compressor with vapor only.
3. Turn unit on. The blower motor and the reheat should be running. Check and record these amperages. Make sure they do not exceed the nameplate ratings.
4. Reset the temperature set point at low. The reheat will go off and the compressor will come on. (On split air cooled units, continue to charge the unit with refrigerant gas). The Chilled Water Valve will open on chilled water units.

CORRECT PHASING OF SCROLL COMPRESSORS:

The scroll compressor is an unidirectional compressor and will only compress refrigerant in one rotation direction. Therefore, the proper rotation of the scroll compressor must be checked. The scroll compressor will run in the reverse direction but it will not pump refrigerant and will draw substantially reduced current as compared to listed values, and will result in elevated sound levels. Scroll compressor will trip on internal protection after running for some time in the reverse direction.

Verification of proper rotation of the scroll compressor can be done by observing that suction

pressure drops and discharge pressure rises when the compressor is energized.

WARNING: EXTENDED IMPROPER ROTATION OPERATION MAY ALSO VOID COMPRESSOR WARRANTY.

5. Check and record the compressor amperage. Make sure it does not exceed the nameplate readings.
6. Check and record the suction and discharge refrigerant pressures.
7. Set Humidity set point at high to energize the humidifier. Check and record the amperage. Compare to the nameplate rating. See "Humidifier Startup" Section for details.
8. Reset the Temperature set point at high to cut off the compressor.
9. Reset the high Humidity set point at low. Check to make sure the compressor comes on to dehumidify.
10. Before completing the start-up procedure, check to make sure the air loop is properly mated to the heat load. Is there any short cycled air? Are there enough grille spaces in the high heat load areas?
11. Reset controls properly. Turn unit off.

OPTIONAL SETTINGS:

Temperature Set Point	72° - 75°F
Humidity Set Point	45% - 55%
Suction Pressure	55-65 Psig
Discharge Pressure	205-300 Psig

REMOTE CONTROLS

The control system is microprocessor based. The solid state, remote, wall mounted MCP-System 2000 is provided as standard controls for field installation.

The MCP-System 2000 Panel has built in Processor, Display Board and Temp/Hum Sensor Board.

The remote wall mounted panel should not be installed more than 25 feet away from the unit.

NOTE: Be sure that the supply air does not hit the Temp/Hum Sensor built in the remote MCP System - 2000 Panel.

Refer to the **MCP-System 2000 User's Guide** for Programming, Operation, Troubleshooting and other detail information

MAINTENANCE

The items listed below should be maintained on a regular basis. The frequency of the maintenance depends entirely upon the usage of the unit.

WARNING: ALWAYS DISCONNECT THE POWER SUPPLY BEFORE DOING ANY MAINTENANCE WORK ON THE UNIT.

1. Filter should be checked regularly for restricted airflow and changed when necessary.
10. Belts-tension and wear should be checked.
11. Blower(s) should be checked for cleanliness and any debris should be removed. Check to see if the blower wheel tightly mounted on the fan shaft and do not rub against the fan housing during rotation.
12. Blower bearing collar should be checked and tightened.
13. Electrical connections should be checked for tightness especially in the power circuit. Also the operation sequence should be checked.
14. Refrigeration lines should be checked for leaks semi -annually.
15. For Refrigeration cycle Suction Pressure, Head Pressure and Superheat should be checked semi -annually.
16. Check the TXV for proper location and contact with the suction line.
17. Check and clean the condensate pan.
18. Humidifier Pan should be removed and cleaned.
19. Cylinder Type Humidifier: "See Humidifier" Section for detail.
20. Check and clean condensate pan.
21. Outdoor heat exchanger (Condenser) coil should be checked for dirt accumulation and Cleaned.
22. Water/Glycol cooled units should be checked for water valve adjustment, water flow and water leaks semi-annually.
23. Stainless Steel Reheat Elements should be inspected regularly for cleanliness. Should inspection reveal corrosion particles on the reheating element or adjoining surfaces appropriate cleaning should be performed.
24. Chilled Water units should be checked for proper valve operation and water leaks semi -annually.
25. **Cleaning:** For cleaning of the panels, a common all -purpose household cleaner may be used. DO NOT USE SOLVENT.

NOTE: It is recommended that these items be checked weekly until a proper maintenance routine can be established.

SPARE PARTS LIST
MAXI-KOOL – MKA/MKE/MKW/MKG/MKC(s)

PART NUMBER	DESCRIPTION	UNIT MODEL(S) (WHERE USED)
-------------	-------------	-------------------------------

REFRIGERATION COMPONENTS

201-020-001	COMPRESSOR 2 TON, 208/3/60	MKA/W(s)-2
201-020-002	COMPRESSOR 2 TON, 460/3/60	MKA/W(s)-2
201-020-003	COMPRESSOR 2 TON, 208/1/60	MKA/W(s)-2
201-030-001	COMPRESSOR 3 TON, 208/3/60	MKA/W(s)-3
201-030-002	COMPRESSOR 3 TON, 460/3/60	MKA/W(s)-3
201-030-003	COMPRESSOR 3 TON, 208/1/60	MKA/W(s)-3
201-040-001	COMPRESSOR 4 TON, 208/3/60	MKA/W(s)-4, 8
201-040-002	COMPRESSOR 4 TON, 460/3/60	MKA/W(s)-4, 8
201-040-004	COMPRESSOR 4 TON, 208/1/60	MKA/W(s)-4
201-050-001	COMPRESSOR 5 TON, 208/3/60	MKA/W(s)-5,10
201-050-002	COMPRESSOR 5 TON, 460/3/60	MKA/W(s)-5,10
201-050-004	COMPRESSOR 5 TON, 208/1/60	MKA/W(s)-5
201-060-001	COMPRESSOR 6 TON, 208/3/60	MKA/W(s)-12
201-060-002	COMPRESSOR 6 TON, 460/3/60	MKA/W(s)-12
239-020-002	EXPANSION VALVE – SVE-2 GA	MKA/W(s)-2
239-030-003	EXPANSION VALVE – SVE-3 GA	MKA/W(s)-3
239-040-001	EXPANSION VALVE – SVE-4 GA	MKA/W(s)-4, 8
239-050-001	EXPANSION VALVE – SVE-5 GA	MKA/W(s)-5,10
236-223-002	HI-PRESS SWITCH MG21-2060	ALL MKA/W(s)
236-121-002	LO-PRESS SWITCH MG20-1229	ALL MKA/W(s)
233-075-001	FILTER DRIER – 1/2" ODF	MKA/W(s)-2-10
233-100-001	FILTER DRIER – 5/8" ODF	MKA/W(s)-12
255-200-022	A/C LIMIT CONTROL:100-425 PSI	ALL MKA(s)

AIR MOVING PARTS

208-010-003	BLOWER – A10-8A (3/4" BORE)	MKA/W/C(s)-2
208-012-003	BLOWER – A12-9A (1" BORE)	MK(s)-2,3,4,5
208-015-003	BLOWER – A15-9A (1" BORE)	MKA(s)-4,5
208-015-013	BLOWER – A15-15A (1" BORE)	MK(s)-8,10,12
208-018-007	BLOWER – A18-18A (1" BORE)	MKA(s)-10,12
206-007-008	MOTOR 3/4 HP, 208/1/60	MK(s)-2
206-007-009	MOTOR 3/4 HP, 208/460/3/60	MK(s)-2

PART NUMBER	DESCRIPTION	UNIT MODEL(S) (WHERE USED)
206-010-006	MOTOR 1.0 HP, 208/1/60	MK(s)-3,4
206-010-007	MOTOR 1.0 HP, 208/460/3/60	MK(s)-3,4
206-015-002	MOTOR 1.5 HP, 208/1/60	MK(s)-5
206-015-004	MOTOR 1.5 HP, 208/460/3/60	MK(s)-5
206-020-005	MOTOR 2.0 HP, 208/460/3/60	MK(s)-8
206-030-003	MOTOR 3.0 HP, 208/460/3/60	MK(s)-10,12
206-050-003	MOTOR 5.0 HP, 208/460/3/60	MKA(s)-10,12
210-144-001	PULLEY-VAR PITCH – 1VP44(5/8")	MK(s)-2,3,4,5,8
210-150-001	PULLEY –VAR PITCH – 1VP50(5/8")	MK(s)-3
210-256-003	PULLEY – VAR PITCH – 2VP56(1-1/8")	MK(s)-10
210-250-003	PULLEY – VAR PITCH – 2VP50(1-1/8")	MK(s)-10,12
210-256-003	PULLEY – VAR PITCH – 2VP56(1-1/8")	MK(s)-12
211-164-001	PULLEY – FIXED PITCH – AK64H	MK(s)-2,3,4,5
211-174-001	PULLEY – FIXED PITCH – AK74H	MKA(s)-2,4,8
211-184-001	PULLEY – FIXED PITCH – AK64H	MKA(s)-5
211-294-001	PULLEY – FIXED PITCH – 2AK94H	MK(s)-8,10
211-284-001	PULLEY – FIXED PITCH – 2AK84H	MK(s)-12
211-296-001	PULLEY – FIXED PITCH – 2AK104H	MKA(s)-12
211-297-001	PULLEY – FIXED PITCH – 2AK114H	MK(s)-10
214-001-039	BELT – “A” SECTION – A39	MK(s)-2,3
214-001-045	BELT – “A” SECTION – A45	MK(s)-4
214-001-046	BELT – “A” SECTION – A46	MKA(s)-8
214-001-052	BELT – “A” SECTION – A52	MK(s)-4 Thru12
215-001-001	BALL BEARING – 3/4” BORE	MK(s)-2,3
215-002-001	BALL BEARING – 1” BORE	MK(s)-2 Thru12
222-100-011	AIR FLOW SWITCH	ALL MK(s)
220-120-202	AIR FILTERS – 2”, 30%	MK(s)-2,3
220-120-252	AIR FILTERS – 2”, 30%	MK(s)-4,5
220-116-252	AIR FILTERS – 2”, 30%	MK(s)-8
220-116-202	AIR FILTERS – 2”, 30%	MK(s)-10,12
<u>WATER REG./CHILLED WATER VALVES</u>		
249-212-021	HEAD PRESS. REG. VALVE, 2-Way, 1/2”	MKW-2
249-213-031	HEAD PRESS. REG. VALVE, 2-Way, 3/4”	MKW-3 Thru 10
249-215-051	HEAD PRESS. REG. VALVE, 2-Way, 1-1/4”	MKW-12

PART NUMBER	DESCRIPTION	UNIT MODEL(S) (WHERE USED)
248-022-212	CW VALVE ASSEY.-24V, 2-Way, NC, 1/2"	MKC-2
248-122-241	CW VALVE BODY, 2-Way, NC, 1/2"	MKC-3
248-122-251	CW VALVE BODY, 2-Way, NC, 3/4"	MKC-4,5,8
248-122-291	CW VALVE BODY, 2-Way, NC, 1-1/4"	MKC-10,12
248-301-411	CW VALVE ACTUATOR-SPST, 24V-MA-5213	ALL MKC(s)
248-201-331	VALVE LINKAGE, AV-600	ALL MKC(s)

REHEAT ELEMENTS

259-252-002	REHEAT ELEMENT 2.5KW @220V	ALL MK(s)
259-257-002	REHEAT ELEMENT 2.5KW @277V	ALL MK(s)

HUMIDIFIER CYLINDERS

262-210-411	HUM CYLINDER #202 – 208/277V, 10 LBS	MK(s)-2 Thru 8
262-210-713	HUM CYLINDER #204 – 440/600V, 10 LBS	MK(s)-2 Thru 8
262-220-413	HUM CYLINDER #303 – 208/240V, 20 LBS	MK(s)-10,12
262-220-733	HUM CYLINDER #311 – 208/240V, 20 LBS	MK(s)-10,12

ELECTRICAL COMPONENTS

274-030-243	CONTACTOR 2 POLE/30 AMPS	MK(s)-2 Thru 8
274-030-323	CONTACTOR 3 POLE/20 AMPS	ALL MK(s)
271-225-310	FUSE-250V, 10A, FRN-R-10	MK(s)-2,3,4,5
271-225-315	FUSE-250V, 15A, FRN-R-15	MK(s)-2,3
271-225-320	FUSE-250V, 20A, FRN-R-20	ALL MK(s)
271-225-325	FUSE-250V, 25A, FRN-R-25	MK(s)-5
271-225-330	FUSE-250V, 30A, FRN-R-30	ALL MK(s)
271-160-210	FUSE-600V, 10A, KTK-R-10	MK(s)-2 Thru 8
271-160-215	FUSE-600V, 15A, KTK-R-15	ALL MK(s)
271-160-220	FUSE-600V, 20A, KTK-R-20	MK(s)-5 Thru 12
275-675-012	TRANSFORMER 75VA-24V, PV: 208/460	ALL MK(s)

MICROPROCESSOR CONTROLS

254-111-001	MCP-SYSTEM 2000 PANEL, VER-2.3P	ALL MK(s)
254-112-001	TEMP/HUM SENSOR BOARD-SYSTEM 2000	ALL MK(s)



8167 Byron Rd., Whittier, CA 90606
 PH (562) 945-8971 FAX (562) 696-0724

STANDARD ONE YEAR WARRANTY

Job Name: _____ Job No. _____ Date: _____

We warranty this Compu-Aire, Inc. computer room unit to be free from defects in material and workmanship; our obligation being limited to repairing or replacing at our factory any part (except as noted below) within one year from the date of shipment to the original purchaser. Parts to be returned to us PREPAID. Proof of start-up date must be submitted to the factory.

This warranty is effective only if the unit has been installed in accordance with our instructions and connected to proper and adequate electric, water and drain services, correctly dehydrated and placed into operation by a competent service representative.

Fan motor compressor warranty is covered by original manufacturer's warranty and any repair or replacement should be made by the local authorized service facility as listed the telephone book.

Maintenance and service such as replacing filters, humidifier cylinder, infra-red lamps, float valve assemblies, belts, cleaning, lubrication, calibration and adjusting are NOT INCLUDED in this warranty.

Replacement or repair parts shall be shipped from the factory pre-paid and invoiced for the full amount. Upon receipt of warranted parts within 30 days with prepayment of the component and which our inspection discloses the parts are defective, and show no signs of misuse, alterations, or abuse, full credit will be issued.

Compu-Aire, Inc. does not assume any responsibility for the labor expense for changing defective parts or replacement of any refrigerant or other cooling medium such as glycol etc.

All parts and goods are thoroughly inspected and packed to meet the requirements of railroad freight classifications bureaus, and under standard shippers risk, when they leave our factory. SHOULD GOODS ARRIVE DAMAGED, call the agents attention to damage, and have same noted on freight bill. For concealed damage, demand immediate inspection from agent of the shipping company and insist on a notation being made on freight bill.

Purchaser-User	Model Number	Serial Number
		Serial Number
		Serial Number
		Serial Number

Authorized by
 X _____
Quality Manager