

PROPRIETARY AND CONFIDENTIAL
 THE INFORMATION CONTAINED IN THIS DRAWING IS THE SOLE PROPERTY OF
 VECTOR ELECTRONICS & TECH., INC. ANY REPRODUCTION IN PART OR AS A WHOLE
 WITHOUT THE WRITTEN PERMISSION OF VECTOR ELECTRONICS & TECH., INC. IS
 PROHIBITED.

REVISIONS				
ZONE	REV	DESCRIPTION	DATE	APPROVED
ALL	A	TABLE REDRAWN ECO 3290	12/10/86	
	B	REMOVED UNUSED PART NOS	02/10/09	
	C	ADDED TS209N	03/04/11	
	D	ADDED TS-425	09/13/12	
	E	ADDED TS240, TS336	02/11/16	
	F	DETAIL 3 SLOT LOADING CUT WAS OPPOSITE SIDE. FINISH IS CLEAR CHEM FILM, WAS PRE-ANODIZED	05/26/11	
	G	ADDED +/-0.030 TOLERANCE TO PARTS LIST. CHANGED TOLERANCE TO 0.015 WAS 0.005.	05/30/17	
	H	ADDED DETAIL 4, P/N TS29850	02/15/18	
	I	DETAIL 3 ADDED LOADING SLOT TO OPPOSITE END.	09/19/19	
	J	ADDED P/N TS25000 (25.000 LONG, DET 1)	02/12/20	
	K	ADDED P/N TS-16900 (16.900 LONG, DET 1)	04/15/20	
	L	ADDED LIGHT GRAIN NOTE 7	01/08/21	

DETAIL 1

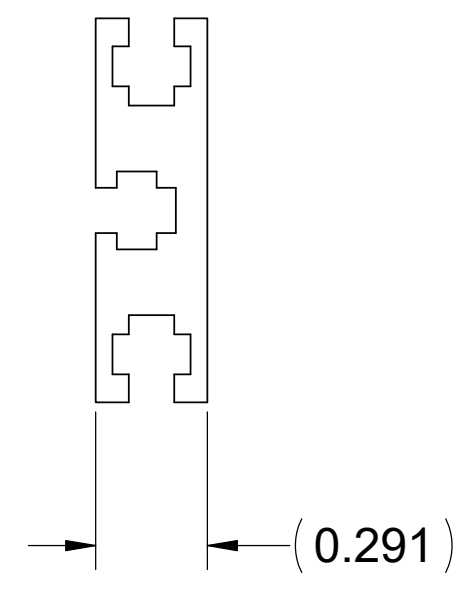
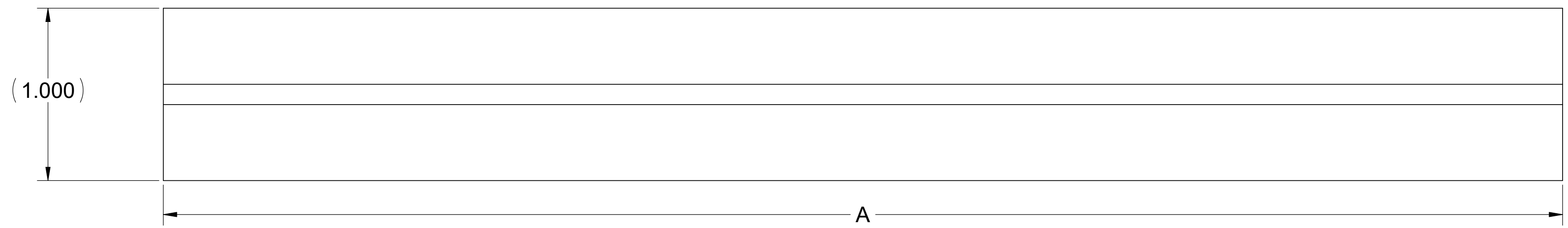

DETAIL 2

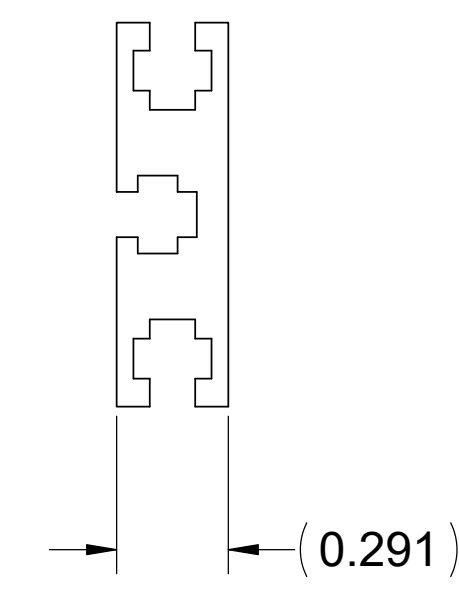
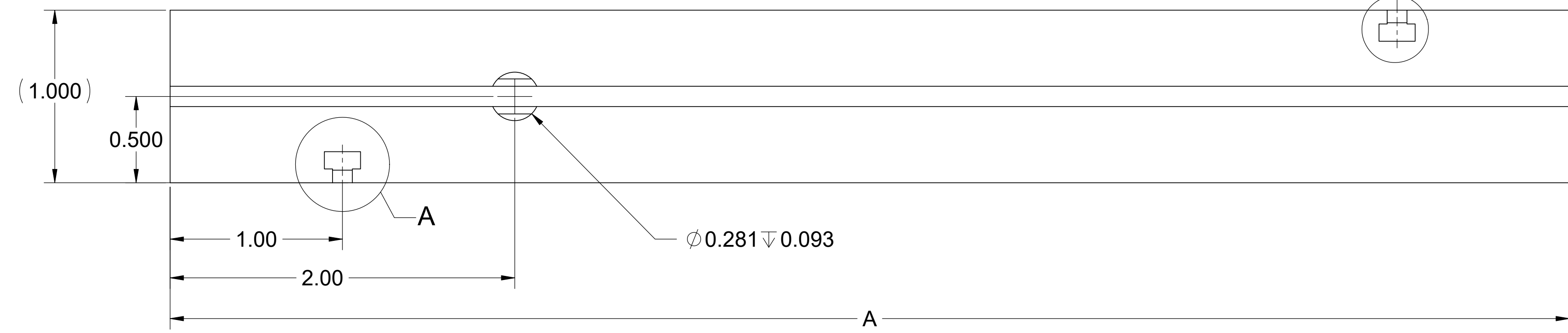

DETAIL 3

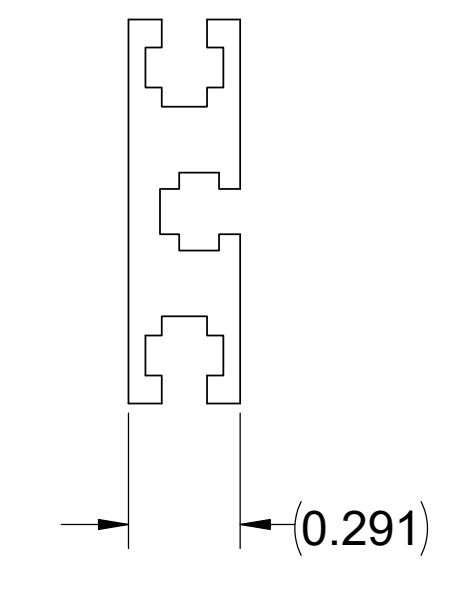
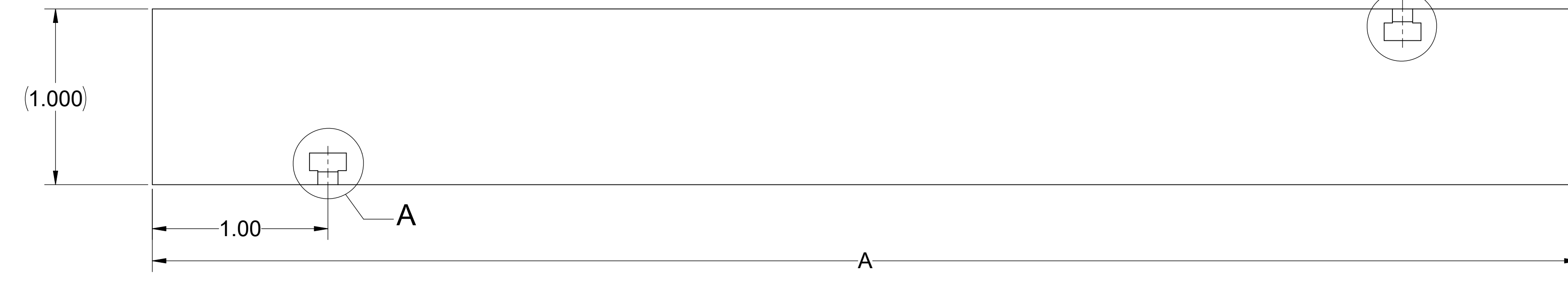

DETAIL 4

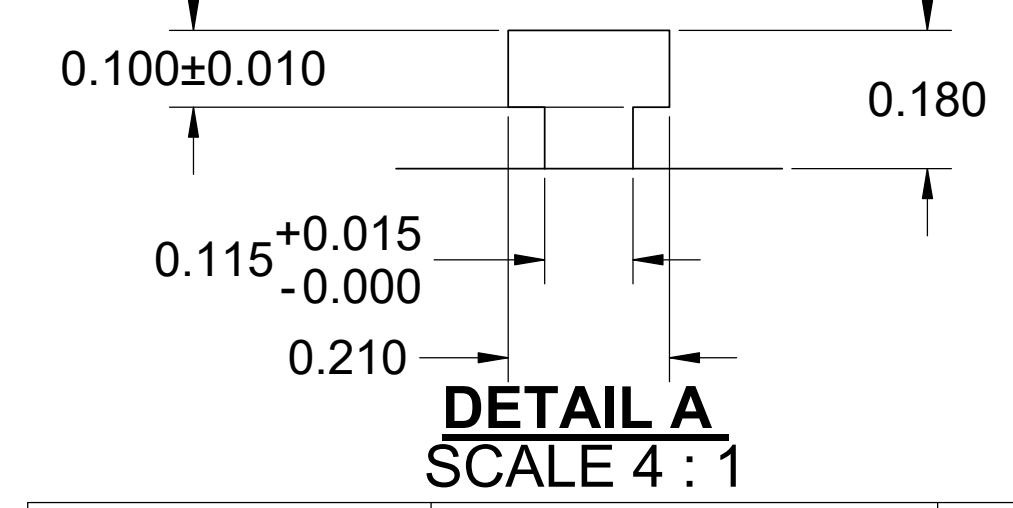
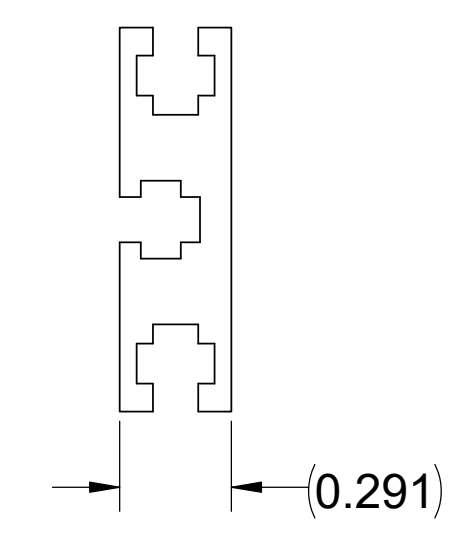
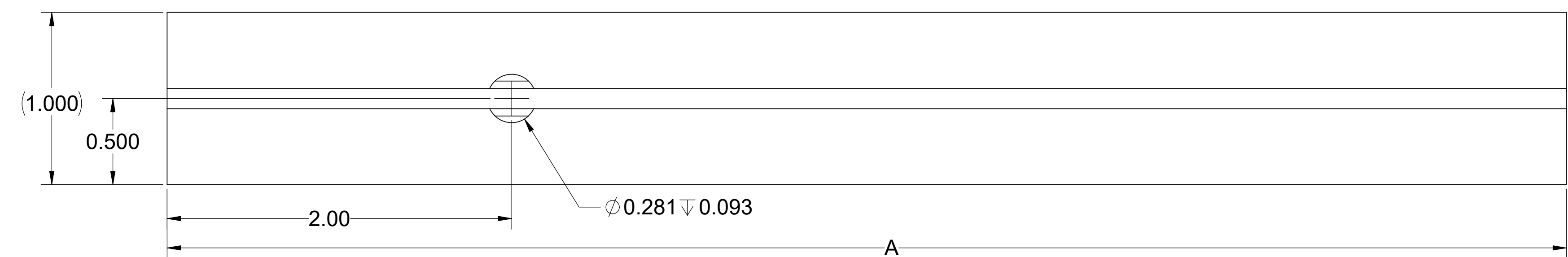

PART NO	DIMENSION "A"	DETAIL NO
TS81	8.120	2
TS169	16.850	2
TS209	20.850 +/- 0.030	2
TS300	30.00 +1.50/-0.00	1
TS600	60.00 +1.50/-0.00	1
TS169-3	16.850	3
TS209N	20.850 +/-0.030	1
TS180	18.000 +/-0.030	1
TS190	19.000 +/-0.030	2
TS195	19.500 +/-0.030	2
TS195-0	19.500 +/-0.030	1
TS170	17.000	2
TS-4125	4.125	2
TS169-10170	10.170	2
TS240	24.050 +/-0.030	2
TS336	33.600 +0.125/-0.030	1
TS169-08500	8.500	2
TS29850	29.850 +/-0.030	4
TS25000	25.000	1
TS-16900	16.900	1

- 6. DEGREASE
- 5. STRAIGHT WITHIN 0.015 PER 10 INCHES IN LENGTH
- 4. CUT ENDS TO BE SQUARE WITHIN 0.0025 PER INCH IN WIDTH
- 3. FINISH : CLEAR CHEM FILM, CLASS 1A, IAW MIL-C-5541
- 2. MATERIAL : ALUMINUM EXTRUSION 6063-T6,
MAKE FROM PART NO. TS100
- 1. REMOVE ALL BURRS AND SHARP EDGES

7. LIGHT GRAIN BOTH SIDES IN DIRECTION OF MATERIAL
 GRAIN USING 180 GRIT

NOTES : UNLESS OTHERWISE SPECIFIED

UNLESS OTHERWISE SPECIFIED	
DIMENSIONS ARE IN INCHES	
TOLERANCES:	
DEC X.X	+/-0.1
DEC X.XX	+/-0.06
DEC X.XXX	+/-0.015
FRACTIONS	+/-0.050
ANGLES	+/-1°
GD & T	: ASME Y14.5-2009
MATERIAL	2
FINISH	3 7

APPROVALS	NAME	DATE
DRAWN	TRUSHAR	02/06/09
CHECKED		
ENGINEER		
QA		

VECTOR ELECTRONICS & TECHNOLOGY, INC. www.vectorelect.com
 11115 VANOWEN ST.,
 NORTH HOLLYWOOD,
 CA 91605

**T-STRUTS
 W/O INSERTS**

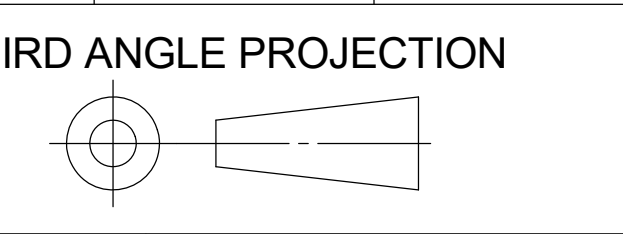

SIZE	DWG. NO.	REV
D	5280006	L
SCALE: 2:1	CAGE CODE: 82893	SHEET 1 OF 1

PROPRIETARY AND CONFIDENTIAL
 THE INFORMATION CONTAINED IN THIS DRAWING IS THE SOLE PROPERTY OF
 VECTOR ELECTRONICS & TECH., INC. ANY REPRODUCTION IN PART OR AS A WHOLE
 WITHOUT THE WRITTEN PERMISSION OF VECTOR ELECTRONICS & TECH., INC. IS
 PROHIBITED.

PART NO	DIMENSION "A"	DIMENSION "B"	DIMENSION "C"	PLACES "N"
TS81-5/90	8.120	7.250	0.435	30
TS169-6/90	16.850	15.750	0.675	64
TS169-5/90	16.850	15.750	0.550	64

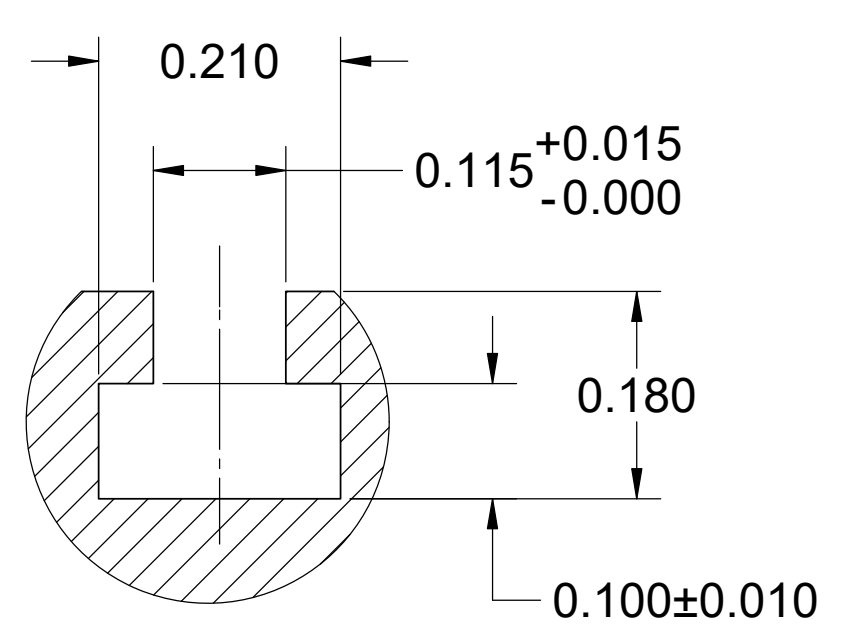

DETAIL E
 SCALE 6 : 1
 2 PLACES

REVISIONS				
ZONE	REV	DESCRIPTION	DATE	APPROVED
ALL	A	RELEASED FOR PROTOTYPE. 100 UNITS OF CCK13S, 50 CCM14S AND 50 CCK13S	02/14/80	
	A1	P/N TS81-5 NO. OF HOLES WAS 30 ACTUAL STOCK PARTS HAVE 31	07/31/80	
	B	P/N TS81-5 "B" DIM. WAS 7.500 NO. OF HOLES WERE 31/ ECO2013	03/26/81	
	C	MOVED 1.000 DIM. LOCATION CALLOUT FOR CLARITY NO ECO		
	D	ADDED TS81-6 & -7		
	D	INC ECO 2628	12/17/84	
	E	INC ECO 3924		
	F	REMOVED P/N# TS81-6, -7, TS169-5, TS209-5	02/10/09	
	G	ADDED P/N TS169-5/90	02/13/13	
	H	CHANGED FINISH TO CLEAR CHEM FILM WAS PRE-ANODIZED	05/26/16	
	I	ADDED LIGHT GRAIN NOTE 9	01/08/21	

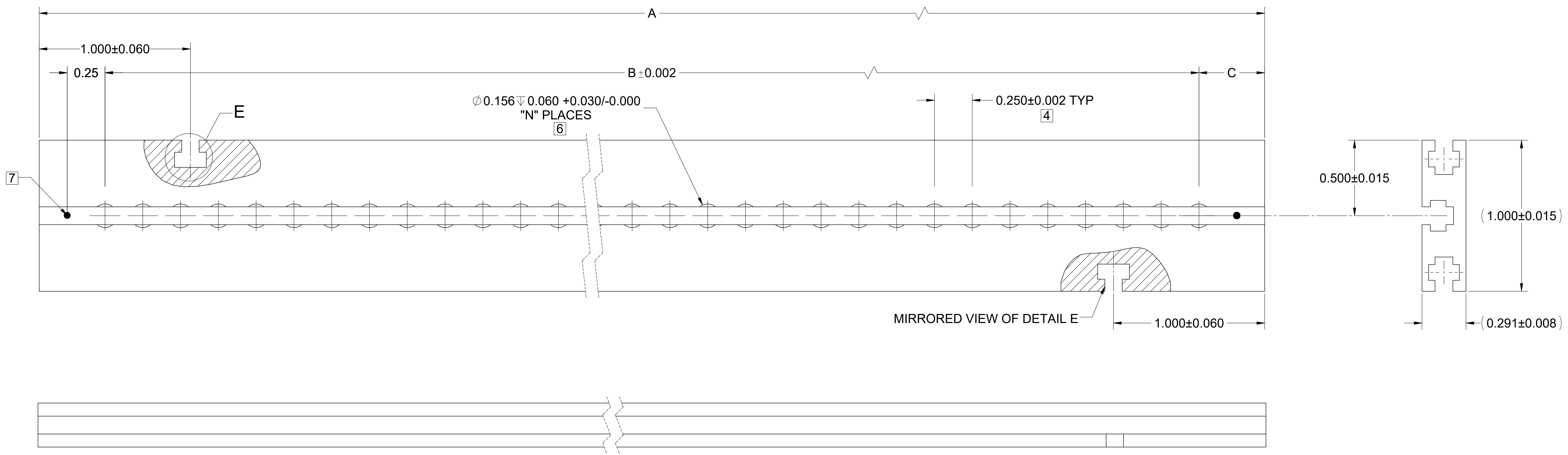

- 9. LIGHT GRAIN BOTH SIDES IN DIRECTION OF MATERIAL GRAIN USING 180 GRIT
- 8. FINISH : CLEAR CHEM FILM, IAW MIL-C-5541, CLASS 1A
- 7. TOOLING MARK MAY APPEAR
- 6. USE Ø0.1565 PUNCH TO FORM RADIUS EQUAL WITHIN ±0.005 FROM C_Q OF SLOT
- 5. PART TO BE FREE OF BURRS AND SURFACE SCRATCHES
- 4. NON CUMULATIVE TOLERANCE
- 3. PART TO BE STRAIGHT WITHIN 0.015 PER 10 INCHES IN LENGTH
- 2. CUT ENDS TO BE SQUARE WITHIN 0.0025 PER INCH IN WIDTH
- 1. MATERIAL : ALUMINUM EXTRUSION 6063-T6, MAKE FROM PART NO. TS100

NOTES : UNLESS OTHERWISE SPECIFIED

INSPECTION REQUIREMENTS	
1	CHECK OVERALL LENGTH
2	CHECK DIMENSION "C"
3	VERIFY 0.156 DIA. WILL FIT INTO PUNCHED RADII & 0.160 DIA WILL NOT FIT INTO PUNCHED RADII
4	CHECK DIMENSION "B"
5	NO CHIPS IN THE BOTTOM OF SLOT

UNLESS OTHERWISE SPECIFIED	
DIMENSIONS ARE IN INCHES	
TOLERANCES:	
DEC X.X	±0.1
DEC X.XX	±0.02
DEC X.XXX	±0.005
FRACTIONS	±0.050
ANGLES	±1°
GD & T : ASME Y14.5-2009	
MATERIAL	1
FINISH	8

APPROVALS	NAME	DATE
DRAWN	TRUSHAR	02/10/09
CHECKED		
ENGINEER		
QA		

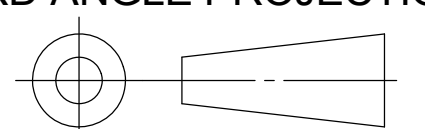

VECTOR ELECTRONICS & TECHNOLOGY, INC. 11115 VANOWEN ST., NORTH HOLLYWOOD, CA 91605 www.vectorelect.com

T-STRUTS SNAP-IN GUIDES

SIZE D	DWG. NO. M6336D4.2	REV I
SCALE: 3:1	CAGE CODE: 82893	SHEET 1 OF 1