

EF-B-T BACnet™ THERMAL/ELECTRIC VAV DIFFUSER INSTALLATION, OPERATION AND MAINTENANCE

Models: EF-B-T BACnet Interoperable Thermal/Electric Square VAV Diffuser

CONTENTS

CONTENTS 1
 DAMAGED FREIGHT CLAIM PROCEDURES 1
 STORAGE 1
 IDENTIFICATION 1
 INSTALLATION PRECAUTIONS 1
 POWER REQUIREMENTS 1
 INSTALLATION 1
 COMMISSIONING 2
 POWER FAILURE 2
 AIR DENSITY COMPENSATION 2
 SYSTEM AIR BALANCING 2
 TROUBLESHOOTING 3
 System 3
 Conditions Outside the EF-B 3
 EF-B Properties 3
 EF-B Electrical 4
 MAINTENANCE 5
 CONTROLLING THE SYSTEM 5
 Supply Air Temperature 5
 Static Pressure 5
 TWO YEAR WARRANTY 6

DAMAGED FREIGHT CLAIM PROCEDURES

When the diffusers are received, inspect for damage, which may have occurred during shipment. If damage is evident, it should be noted on the carrier's freight bill. A written request for inspection by the carrier's agent should be made at once.

STORAGE

Cartons should always be stacked on end with the arrows on the cartons pointing up. Do not stack cartons flat on the sides. Excessive weight may cause damage to the diffusers. Do not store for prolonged times at temperatures exceeding 130°F/56°C. Acceptable humidity level 5-95% relative humidity noncondensing.

IDENTIFICATION

Models are factory shipped one per carton. The model designation is on the diffuser and on the carton.

INSTALLATION PRECAUTIONS

When installing diffusers make sure construction debris does not enter the diffuser or duct system.

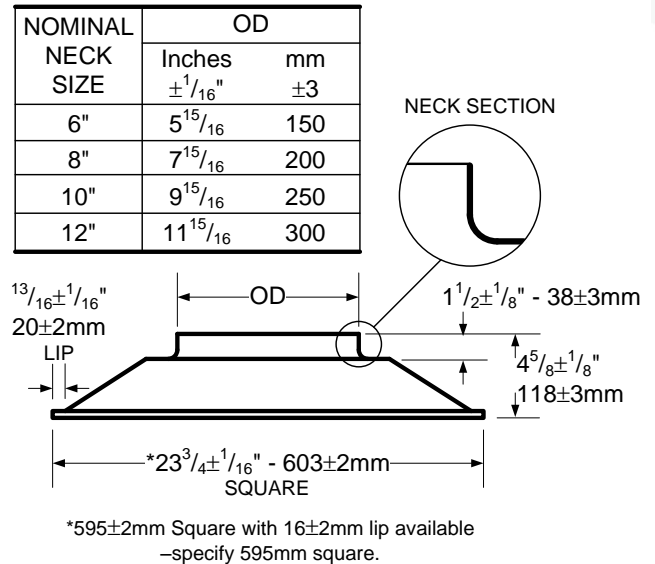

Fig. 1 Dimensions

Because the EF-B controls room temperature by sensing the air induced up the center of the room, care should be taken not to disturb room air induction and entrainment. For example, location next to walls or dropped lights results in the reflection of supply air back at the Therma-Fuser diffuser and should be avoided. A three way blow Therma-Fuser diffuser should be used in this instance if either the light or the Therma-Fuser diffuser cannot be relocated.

POWER REQUIREMENTS

24 +3/-1VAC 10VA max.

INSTALLATION

1. Inspect the carton for damage before opening. Notify carrier if external damage exists. Submit all claims for shipping damage to the carrier.
2. Move diffusers (in cartons) to installation area. Note unit identification.
3. Remove cardboard box and cardboard insert. Recycle packing material.
4. If other than 4 way blow pattern is installed note the "AIRFLOW" markings on the top of the diffuser and locate those sides in the proper direction.
5. Install in ceiling grid. Install T-bar support wire close to each corner of diffuser. Make sure that only wire suspended T-bars are used to support

EF-B BACnet THERMAL/ELECTRIC VAV DIFFUSER INSTALLATION OPERATION AND MAINTENANCE

diffuser weight. Follow all local codes for seismic restraints. (Adaptor frames are available for other than lay in ceilings.)

6. Connect and secure the supply duct to the collar. Flexible duct should NOT be formed in a centerline radius of less than 1½ times the duct diameter.
7. Connect shielded twisted pair network wiring to the screw terminals labeled (+) and (-) and connect the drain wire to COM (see Fig. 7 Wiring Diagram). All network wiring should be to ASHRAE Standard 135 and EIA-485.
8. Connect 24 VAC power to the screw terminal labeled 24VAC (POWER IN) (see Fig. 7 Wiring Diagram).
9. Commission all EF-B diffusers (see BACnet Object List Form 091.202).
10. Balance the system (see System Air Balancing below).

COMMISSIONING

The EF-B unit is shipped with default values and will start to operate once power is supplied.

1. To establish communication, switch dip switch AUTOM 'off' and set the MAC address using the seven dip switches labeled 1 through 64 using standard seven bit addressing (i.e. 1 'on' is 1, 1 'off' and 2 'on' is 2, 1 'on' and 2 'on' is 3, etc...).
2. Turn on the 24VAC supply power.
3. Discover ("who is") the EF-B using preferred BACnet software.
4. Re-assign the Instance Number (ID Number) as required by the specific network. (A random instance number is assigned at the factory.)
5. Refer to the EF-B Object List (Form 091.202) and configure the different properties of the EF-B as required by the project.

POWER FAILURE

Objects designated as Configuration are stored in non-volatile memory so that the EF-B diffusers can resume normal operation when power is restored after failure. See the EF-B Object List (Form 091.202) for a complete list of the Configuration Objects.

AIR DENSITY COMPENSATION

Installation at altitudes above 1650ft / 503m requires modified settings for air density effects (see BACnet Object List Form 091.202).

SYSTEM AIR BALANCING

VAV systems are balanced for design air volume at maximum air flow and systems using Therma-Fuser VAV diffusers are no exception. When all the Therma-Fuser diffusers are set for maximum airflow by fully

opening them, the system is really a constant air volume system and is balanced as a constant volume system. Balancing dampers are best located at the takeoff before the run out to the diffuser.

1. Prepare system for balancing. (Make necessary checks for diversity, fan capacities, fan rotation, minimum outside air requirements, duct leaks and static pressure controller design setting. Set outside air control damper for minimum air and return air control damper for maximum air.)
2. Open EF-B diffusers for balancing.
 - a. Open appearance panel.
 - b. Unhook tension spring from bracket adjacent to thermal actuator (see Fig. 2 Tension Spring and Fig. 4 Actuator Extension).

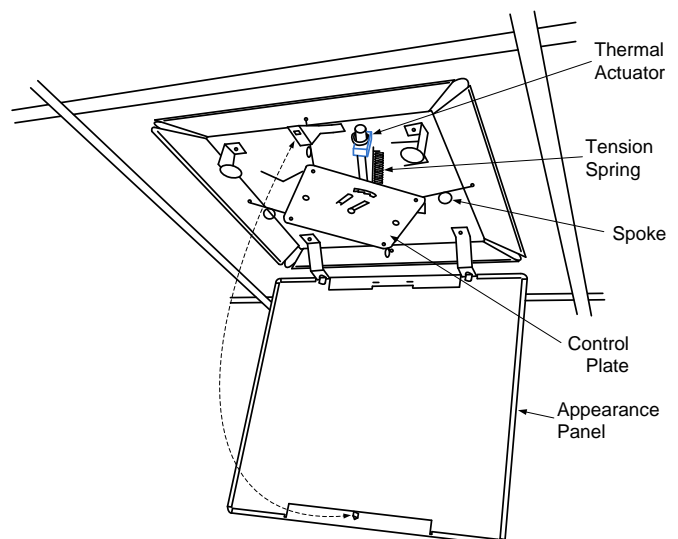

Fig. 2 Tension Spring

- c. If perimeter blades do not immediately drop to open position, turn the control plate slightly until they open.
 - d. Close appearance panel.
- or
- Set the value of the Object analog_value_25 (iOverride) to '1'. Allow 10-15 minutes for all diffusers to open fully.
3. Start fans, adjust system for 100% air flow and make system checks. (Measure static pressure across filters and coils and at sensor for static pressure controller. Measure supply, return and branch duct air flow.)
 4. Measure air flow from each EF-B diffuser and adjust the damper at the duct takeoff to obtain maximum design air flow. Air flow measurement may be with a direct reading diffuser balancing hood or air velocity meter. In either case, measurements are made with all appearance panels in place. This is because the appearance panel affects pressure drop through the diffuser.

When velocity meter is used to measure the discharge velocity, the velocity is measured at the top edge of the housing.

5. When balancing is complete, return each model EF-B diffuser to normal operation by:
 - a. Open appearance panel.
 - b. Attach tension spring to bracket (removed in step 2b).
 - c. Close appearance panel.or
Set the value of the Object analog_value_25 (iOverride) to '0'.

Note: Diffuser noise is caused by higher velocity air through the diffuser which is caused by a high static pressure. Acutherm recommends a static pressure no higher than 0.25"wg / 62Pa at the inlet to the diffuser. Some system designers may accept higher noise levels and opt for a higher static pressure. Care should be taken not to exceed the design maximum static pressure at the takeoff to the first EF-B diffuser after the static pressure control or, if none, after the fan.

TROUBLESHOOTING

Before examining the Therma-Fuser diffuser for failure it is worth the time to be sure the system is functioning properly and that something has not been overlooked.

System

The system should be:

1. Delivering 50°-68°F/ 10°-20°C supply air when in the cooling mode.
2. Delivering 80°-120°F/ 26.5°-49°C supply air when in the heating mode.
3. Maintaining a constant supply air temperature.
4. Maintaining static pressure at the inlet to each Therma-Fuser diffuser between .05 and .25"wg / 12 and 62Pa.
5. Maintaining continuous fan operation during occupied hours.

Once the above checks have been completed examine and record the following:

Conditions Outside the EF-B

6. Room temperature 4ft/1200mm above the floor directly under the Therma-Fuser diffuser.
7. Supply air temperature at the Therma-Fuser diffuser. (Temperature may vary over time. Several measurements at different times may be required.)
8. Static pressure at the inlet of the Therma-Fuser diffuser.

EF-B Properties

9. Check that 24⁺³/₋₁VAC is supplied to the diffuser across the terminals labeled 24VAC (POWER IN) (see Fig. 7 Wiring Diagram).
10. Determine the current set point.
 - a. Use a computer on the network with BACnet network management software to select the specific EF-B unit.
 - b. Discover the diffuser Objects and locate analog_input_3 (oEffectStpt). The value of this Object is the current set point for the EF-B unit.
 - c. Check that other Objects are not overriding the current set point or limiting flow. The following are Objects that can override normal operation and the default setting for each.
 - i. binary_value_0 (iVancancy Mode) = 0
 - ii. analog_value_0 (cMaxFlow) = 1000
 - iii. analog_value_1 (cMinFlow) = 0
 - iv. analog_value_2 (cMinStbyFlow) = 0
 - v. analog_values_4-9 (set points)
 - vi. analog_value_10 (cStPtLimit) = 2
 - vii. analog_value_11 (cStPtReset) = 0
 - viii. analog_value_12 (cMaxHeatsp) = 100
 - ix. analog_value_13 (cHCMMode) = 0
 - x. analog_value_15 (cVacSpOfst) = 2
 - xi. analog_value_21 (iOccMode) = 0
 - xii. analog_value_22 (iHCMMode) = 0
 - xiii. analog_value_23 (iTempSetpt) = 3276
 - xiv. analog_value_24 (iFlowSetpt) = 3276
 - xv. analog_value_25 (iOverride) = 0
 - xvi. analog_value_26 (iRmTemp) = 327
 - xvii. analog_value_27 (iSATemp) = 327
 - xviii. analog_value_28 (iFlowRate) = 3276
 - xix. analog_value_29 (iCO2Level) = 0

If they are other than as shown above, temporarily remove the override to make the Objects normal before further checking.

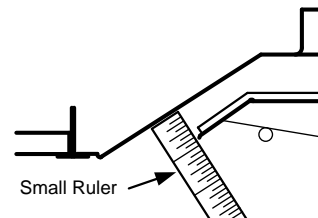

Fig. 3 Blade Opening

EF-B BACnet THERMAL/ELECTRIC VAV DIFFUSER INSTALLATION OPERATION AND MAINTENANCE

11. Measure the damper blade opening from the edge of the housing perpendicular to the housing (see Fig. 3 Blade Opening).
12. Measure the thermal actuator extension (see Fig. 4 Actuator Extension).

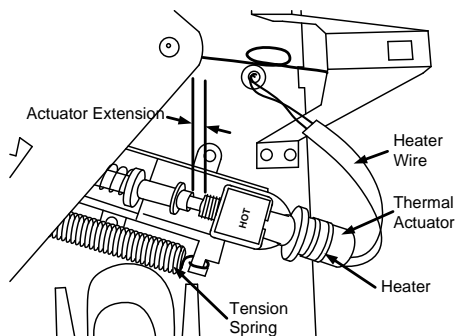

Fig. 4 Actuator Extension

13. Use the information from the steps above to determine if the damper blades are correct for the conditions.
 - a. Determine mode. The EF-B unit should be in cooling if the supply air temperature is below the set point. It is in heating if the supply air temperature is above both the room temperature and the set point.
 - b. For room temperatures more than 2°F/1.2°C from set point, damper blades should be moving to as shown in the Fig. 5 Troubleshooting.

	Cooling		Heating	
	+2°F / 1.2°C	-2°F / 1.2°C	+2°F / 1.2°C	-2°F / 1.2°C
Damper Blade Position	Open	Closed	Closed	Open
Thermal Actuator Position	> 5/8" / 16mm	< 1/2" / 12mm	< 1/2" / 12mm	> 5/8" / 16mm
Voltage to Heater	> 25VDC	< 1VDC	< 1VDC	> 25VDC

Fig. 5 Troubleshooting

Notes:

- i. Room temperature more than ±2°F/1.2°C from set point has been selected as a general rule of thumb for trouble shooting to avoid more complicated control algorithms within that band. Control is intended to be tighter but will depend on system conditions.
- ii. If any of the set points are changed to achieve full open or full closed conditions, wait 5 to 10 minutes to make sure the room and system have stabilized.
- iii. For room temperatures less than 2°F/1.2°C from set point, the damper blades may be somewhere between open and closed.

14. If the damper blades are not according to the table, check the following:
 - a. Are maximum or minimum flow settings or any other overrides limiting opening or closing? See step 10.c. above. Record any maximum or minimum flow settings or other overrides and return to that setting after troubleshooting. For troubleshooting, reset maximum flow to 1000 and minimum flow to 0. Wait 5 to 10 minutes – see step 13.b., note ii.
 - b. Confirm that the heater is wrapped around the thermal actuator (see Fig. 4 Actuator Extension). If not re-wrap it.
 - c. Check that the thermal actuator extension is according to the table. If the extension is correct and the damper blades are not, check the linkages to the damper blades.
15. If there are no limiting flow stops or overrides and if the heater is wrapped correctly, measure the voltage supplied to the heater. Remove the controller cover and measure the voltage across the terminals marked HTR and HTR (see Factory Wiring on Fig. 7 Wiring Diagram). If the voltage is not according to Fig. 5 Troubleshooting, complete EF-B Electrical below before contacting Acutherm.

EF-B Electrical

16. A green LED near the 24VAC Supply Power terminals should be lit indicating good supply voltage (see Fig. 7 Wiring Diagram).
17. Check the fuse near the 24VAC Supply Power terminals (see Fig. 7 Wiring Diagram).
18. Reset the EF-B using the network command ReinitializeDevice. If ReinitializeDevice is unavailable from the preferred BACnet software then cycle the power by unplugging the 24VAC Supply Power terminals and then reconnecting them.
19. Use a computer on the network running the preferred BACnet software to check the Status_Flags on each of the following Objects: analog_input_0 (oRmTemp), analog_input_1 (oSATemp), and analog_input_3 (oFlowTemp).
 - a. If Status_Flag 'overridden' then check analog_value_26 (iRmTemp), analog_value_27 (iSATemp), and analog_value_28 (iFlowRate) respectively.
 - b. If Status_Flag 'in_alarm', 'fault', or 'out_of_service' then check the sensors.
 - i. Remove the controller cover.
 - ii. Remove the wires to each sensor (ROOM TEMP, DUCT TEMP, and FLOW1-4 TEMP) from the terminals (see Fig. 7 Wiring Diagram).

- iii. Measure the resistance between each wire and the terminal marked common.

Temperature	Resistance
50°F / 10°C	2000 Ω
77°F / 25°C	1000 Ω
95°F / 35°C	650 Ω

Fig. 6 Thermistors

- iv. If the resistance is correct per Fig. 6 Thermistors, reinstall the wire making sure that it makes contact with the terminal.
- v. If the resistance is outside the range, check the common terminal connections.
- vi. If all common wires are in contact with the terminals and the resistance is still outside the range, contact Acutherm.

MAINTENANCE

The moving parts of the EF-B diffuser have no maintenance or lubrication requirements. We are often asked to recommend periodic maintenance procedures and a spare parts stock. Recommended maintenance is to clean the outer surfaces of the Therma-Fuser diffuser - nothing else. We do not recommend stocking any spare parts. Our customers also confirm that stocking is unnecessary.

CONTROLLING THE SYSTEM

References:

- System Design section of EF-B Brochure (Form 091.101).
- Chapters 2.2, 3.1 and 3.2, pg. 6, 7 and 8, Designing Modular VAV Systems (Form 5.2).
- Air Handling and Fan Coil Units Subzoned with Therma-Fuser VAV Diffusers (Form 6.7).
- Dx Equipment Zoned with Therma-Fuser VAV Diffusers (Form 6.5).

Supply Air Temperature

The sources of cooling and heating are controlled from supply air temperature. As with all VAV systems the goals are to achieve a constant supply air temperature (may be reset to another **constant** supply air temperature) and to limit the supply air temperature. Limits for supply air temperature should be between 50°F/10°C and 68°F/20°C when cooling and between 80°F/26.5°C and 120°F/49°C when heating. The heating temperature limit should be as low as possible. These objectives are best achieved by modulating chilled water valves, hot water valves and other variable equipment from supply air temperature. On/off equipment such as DX compressors and electric heat are cycled from supply

air temperature. Use a discharge air sensor for the supply air temperature signal.

Mode change between heating, recirculation and cooling is controlled from room temperature. Object analog_input_0 (oRmTemp) from the EF-B Therma-Fuser diffuser may be used for mode change. A "majority rules" approach is recommended.

Static Pressure

As with all VAV systems, the fan must run continuously during the occupied hours. Goals of static pressure control are to provide enough static pressure to obtain the required air volume especially at the diffuser farthest from the fan, to limit static pressure at both full flow and turndown, to avoid diffuser noise and to provide pressure independence or consistent operation as the system flow changes. These objectives can be achieved with the usual methods of automatic static pressure control: bypass dampers, zone dampers, and fan speed control (variable frequency drives, inlet dampers, etc.). Locate the static pressure sensor as far down the duct as possible - at least $\frac{2}{3}$ down the duct from the first takeoff.

Network Wiring Notes from ASHRAE 135

The BACnet MS/TP protocol uses EIA-485 (RS485) as its physical layer. EIA-485 is a three conductor network. All network wiring should be to the ASHRAE Standard 135 (summarized below) with the twisted pair used for '+' and '-', maintain polarity, and use the drain wire as the third conductor for the 'COM'.

ASHRAE Standard 135 9.2.1 Media for network wiring:

- Topology: daisy chain, bus
- Wire: shielded twisted pair (with drain), 18 AWG 0.82mm² conductor area
- Impedance: 100-130Ω
- Capacitance, distributed: between conductors <100pF/m (30pF/ft) and between conductors and shield <200pF/m (60pF/ft)
- Max length: 1200m (4000ft) per segment
- Use terminating 120Ω ¼W 5% resistors at each end

EF-B INTEROPERABLE VAV DIFFUSER INSTALLATION OPERATION AND MAINTENANCE

FORM 091.201 REV 14303

(Supersedes FORM 091.201 REV 1303)

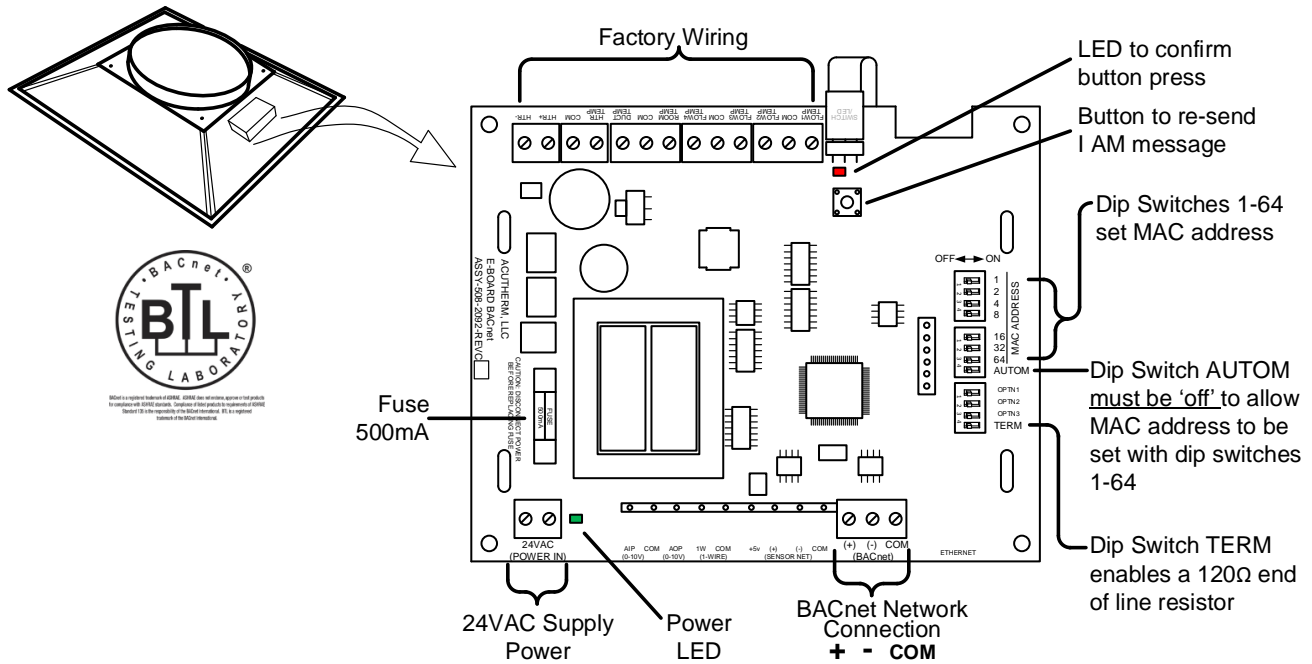

Fig. 7 Wiring Diagram

TWO YEAR WARRANTY

Acutherm warrants that its Model EF-B diffuser, exclusive of any options and accessories (whether factory or field installed) shall be free from defective material or workmanship for a period of two (2) years from the date of shipment and agrees to repair or replace, at its option, any parts that fail during said two (2) year period due to any such defects which would not have occurred had reasonable care and proper usage and all parts and controls remain unaltered. Acutherm makes NO WARRANTY OF MERCHANTABILITY OF PRODUCTS OR OF THEIR FITNESS FOR ANY PURPOSE OR ANY OTHER EXPRESS OR IMPLIED WARRANTY WHICH EXTENDS BEYOND THE LIMITED WARRANTY ABOVE. ACUTHERM'S LIABILITY FOR ANY AND ALL LOSSES AND DAMAGES RESULTING FROM DEFECTS SHALL IN NO EVENT EXCEED THE COST OF REPAIR OR REPLACEMENT OF PARTS FOUND DEFECTIVE UPON EXAMINATION BY ACUTHERM. IN NO EVENT SHALL ACUTHERM BE LIABLE FOR INCIDENTAL, INDIRECT OR CONSEQUENTIAL DAMAGES OR DAMAGES FOR INJURY TO PERSONS OR PROPERTY. Acutherm shall not be responsible for freight to or from its plant in connection with the inspection, repair or replacement of parts under the terms of this limited warranty nor for cost of removal or installation.

