

March 2022

www.nmra-scwd.org

Volume 53 No. 7

CATCH THE TRAINS!

54th Annual

MadCity

**MODEL RAILROAD
SHOW AND SALE**

Sat. Feb. 19, 9AM-5PM • Sun. Feb. 20, 9AM-4PM, 2022
Alliant Energy Center, Exhibition Hall, Madison, WI

Next SCWD Meet
VERONA SENIOR CENTER (Map Page 6)
 March 6, 2022 at 1:00 pm

Next BOD Meeting:
 March 14, 2022 at 7:00 pm
 ZOOM Meeting



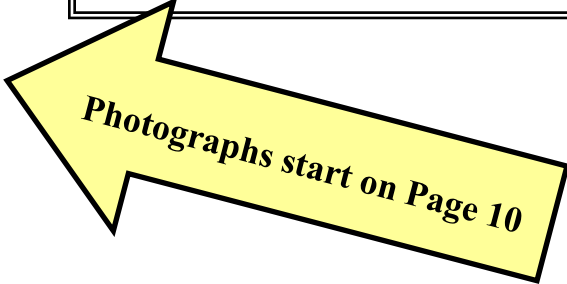

Super's Report

Phil Hottmann
 Division Superintendent

Well, I think we are all feeling good about the level of success of the Mad City Train Show and Sale. I don't know the exact totals yet, but I believe we may be close to our projected targets. There were a lot of indications that the hobby is still alive and thriving. Micro Mark mentioned that their business doubled during the pandemic. I believe we still have work to do to bring more people that are getting into the hobby to join our organization. Steve was able to sign up five new members at the show.

We really need to thank Bob McGeever and his team for all their work through these challenging times. I know there was a lot of work being done with the social media site, marketing and bringing in more credit card machines. Bob Boelter, Tom Morrison, Dave Down, Webb Winn, Corky, Larry and Sue Bunce all need special thanks for the tremendous work they did to make this show a success. We also need to thank all of the other members whether they participated with modular groups, exhibits or were volunteers at the show.

The Company Store did a great amount of business. Webb estimated that we sold about 60% of our inventory. There were some great bargains for those attending our show.

At this point we are starting to look forward to putting on next year's show. We'll probably need to make a few adjustments, but our hope is to break-even on the show.

It turns out that there is another modeling show at the Alliant Center on March 5th. It is the IPMS (International Plastic Modeler's Society). I'm not much of a plastic modeler, but this might be a good opportunity to see what others can do with this material. I also think this may be opportunity to see some great weathering and scenery techniques.

We are planning to have a Summer Picnic again. More details will come as we are able to confirm reservations.

Phil

Clinic Column

by Ken Hojnacki

Our thanks go out to Bill Clancy for another outstanding scenery clinic; Bill knows how to really get down and dirty when it comes to ground cover. I think we were all impressed at how good Bill's grout "dirt" looks. Thanks also to Ed Koehler from the Sunrise Trail Division who fired us up about how to model realistic fire equipment and facilities on our railroads. Lots I never thought about before. Ed's handout for his firefighting clinic is available on the SCWD website.



For March, we'll get an interesting perspective on getting involved with 12" to the foot railroading. Peter Schierloh received a gift from his family of Nevada Northern Railway's Railroad Experience Week. Peter will give us a tour of one of the most complete historical railroads and its facilities, both steam and diesel, and give us an inside look at a program that lets you get hands-on with many aspects of a real railroad.

After the break, we will have an NMRA clinic by Clark Kooning, MMR. Clark has been a leader in the Modeling With The Masters clinics at national conventions. Many of us use Design Preservations kits or wall sections to build structures for our layouts. I have had some frustrations doing that and Clark takes us through lots helpful tips to make not only DPM kits better but can apply to other structure efforts.

So join us for some big and little railroad adventures at the March meeting.

Ken

Layout Tours

Phil Hottmann Chair

We didn't have any layouts open for the February meeting due mainly to the surge in COVID cases. For March we are planning to visit Jerry Lawler's layout. Jerry stated that he has completed quite a bit of new work since we have last seen his layout. It's always a lot of fun to visit Jerry's layout. I'm looking forward to the visit.

Phil

Modeling Project

By Mike Vivion

With less than 2 months left, I remind all of you who signed up for this year's Modeling Project, that you should have your mini-diorama ready to bring to our meeting on April 3rd. As previously announced, there will be separate judging, by popular vote, for HO and N scale entries. Prizes for 1st, 2nd and 3rd place will be awarded for each category. In case you have forgotten the rules for making your entry, I refer you to the "Model & Photography" subsection under "Contests" on our Division home page at nmra-scwd.org. Also, I remind you that in order to get your \$5.00 deposit back for the contest, you must bring your entry to the April meeting for judging (even if it is incomplete).

Hope to see a great turn-out of entries in April!

Mike



HAVE 50 MODEL RAILROADING CLINICS RIGHT IN YOUR LIVING ROOM.

Just because you can't make it to a national convention doesn't mean you have to miss out. Right now the NMRA's Kalmbach Memorial Library has over 50 DVDs of clinics presented at national conventions from 2002 to 2010. All available to NMRA members for the cost of postage.

So you can see clinics on everything from decoders to design, tools to techniques, helixes to highways, and research to resin casting.

All from the comfort of your very own couch.

Visit www.nmra.org and go to the Kalmbach Memorial Library page for a complete listing.

Then, get that popcorn ready.



We make it even more fun.

www.nmra.org
4 2 3 - 8 9 2 - 2 8 4 6

Contest Column

Dave Down, Chair

The Feb contest featured all models, no photos. The theme was **Non-Railroad Structures** (but served by railroads), which meant structures not owned by the railroad.

The **March** contest theme is **Open Freight Cars**.

- A. Open Hoppers
- B. Gondolas
- C. Flat Cars
- D. Miscellaneous (Any open car that doesn't fit in the first three categories)

Good luck and I'm looking forward to seeing all your entries, especially in the Miscellaneous category!

February contest results: Non-Railroad Structures

Model Contest:

Cat. A. Manufacturing (non-food)
 1st Don Swinton: The Weber Company



Cat. B. Manufacturing (food)
 1st Art Dawson: Berenwald Farms dairy transfer station
 2nd Don Swinton: pickle factory



Cat. D. Commercial
 1st Dave Lendved: Toby's Ice Cream



Photo Contest: There were no entries.

There will be no popular vote contest in April as we will be having the model project contest entries will be received.

Happy modeling!
Dave

A BIG thank you

MadCity Train Show Volunteers

As you read this the train show for 2022 is receding into the distance. We had a few moments of “how did we do this before?” and a lot of moments of “oh, that’s right, this is how we are supposed to do this.” Now we have successfully staged the 2022 train show and are hopefully back on a more normal path forward. Which means I will be contacting all of you for volunteer jobs in about eight months to get ready for February 2023. Block this out in your calendars now so you are ready to tell me “yes, I’ll be there.”

Seriously, though, I want to shout out a heartfelt “thank you” to all the volunteers who helped us make the show a success. I didn’t make too many mistakes, but the ones I did make were pretty hard to miss, so I thank you all for adapting and making things work when something didn’t exactly go to plan. As an organization we also need to recognize the contributions of spouses and non-member friends of the SCWD who pitched in to help out. That help was very important.

I expect to be having conversations with many of you over the next weeks to start the process of evaluating our volunteer recruitment efforts to prepare for next year. I know you have ideas because many of you shared some of your thoughts with me.

We had a good show this year and it was only possible because of the work all our volunteers put in to make it happen. (If we have an even better show next year maybe I’ll be able to ask for a raise!). Again, thank you all.

Dave Down
 Volunteer Coordinator
 MadCity Train Show
 608-235-5436. (Leave message)





The BOD candidates in alphabetical order:

Dr. Bill Clancy



My passion for model railroading began in the 1950's as 12 year old building Strombecker wooden freight cars and built a very, very small railroad. As a competitive athlete through high school and college followed by medical school and orthopedic residency, I had no time to devote to it.

I left the U.S. Naval Academy as Head Team Physician to come to Madison in 1974 to be the U.W. Head Team Physician and orthopedist and started the U.W. Hospital Sports Medicine Clinic and program. Between clinics and team coverage, I had little time available but managed to build a small layout with the guidance of Pete Olson and Al Potts.

In 1989 I left for Birmingham, Alabama. With a little more time available, I built two large HO layouts. In 2010 at the request of the U.W., I returned as Head of Sports Medicine and Head Team Physician and retired five years ago which allowed me and my wife to go full steam ahead with my passion.

I first joined the NMRA and the SCWD in approximately 1978. In October of 2013, I started building a large HO layout which is now up and running.

I really enjoy the monthly SCWD meetings particularly the clinics but even more the wealth of knowledge and friendships of the members who graciously share their skills and knowledge which I sorely needed and will need more in the future.

Having been elected to the SCWD Board of Directors for the past four years, I have had the opportunity to become more active in our Division. It was a great eye opener to see how passionate and hardworking the board members were in trying to advance interest, provide more relevant information and make our monthly meetings more meaningful for our membership. I certainly would like to continue on the Board of Directors to help advance the vision of the Division.

David Dingman



With retirement starting to become a light at the end of the tunnel and another weekend spent at the Mad City Model Railroad Show, I decided to join the NMRA and SCWD in the spring of 2016 to become more actively involved in model railroading again. I have participated in the Mad City Model Railroad Show as a volunteer for the last several years to become better acquainted with the members of the SCWD and also help support the division. I was recently honored by being asked about becoming a member of the SCWD Board of Directors.

My first memories of trains involve watching prototype trains maneuver around the Los Angeles area then riding on an ATSF passenger train to San Diego and back. I remember being thrilled to see a real operating steam locomotive and train up close at Disneyland when I was 7 years old. A short time later my father acquired a friend's model railroad layout (12' x 16') that had both O and HO scale track and trains running at the same time. That instilled a lifelong love of both model and prototype railroading. Interest in model railroading survived a very challenging test during the next forty plus years as college, multiple moves and work all limited participation to reading Model Railroader magazine and going to model railroad shows.

David Down



Hello SCWD members. My name is Dave Down and I am running for re-election to our Division's Board of Directors. I have been interested in model railroading starting with my first train when I was 8 years old. I had a large American Flyer set which was big enough to run around both our living room and parlor. My father also introduced me to HO trains when I was 12 when he gave me a refrigerator car (which I still have). While I was in college my parents moved and had an auction, which was the last time I saw the American Flyer. After that time I was pretty much a closet model railroader until I approached retirement.

During the next 45 years I read magazines, acquired

some engines and cars, and started work on a couple different layouts. Work took me on the road and gave me too many chances to procrastinate, so when I approached retirement I set a goal of becoming a model railroader for real. I decided to become a member of the SCWD in the fall of 2015 with the goal of meeting and getting to know people who have already had success in the hobby, and to find which aspect of the hobby will give me the most satisfaction. As a result, I have acquired a model railroad layout based on the Soo Line (Bill Ehlert's Rugby Junction) and hope to have it ready soon for visits, virtual or in person, as the pandemic allows.

It seems obvious to me the SCWD can only be successful in building the hobby when it is effective in helping modelers develop their skills and expand their interests. And it also seems obvious to me the SCWD will only grow and achieve success when its members use their abilities and skills to make the SCWD relevant to its members. I am running for the Board of Directors in an effort to give back to the organization and the hobby. My goal is to encourage others to get involved and to make SCWD an attractive organization to current, new, and future members.

Phil Hottmann

I have been a model railroader for 28 years. Most recently I have served on the SCWD B.O.D as Superintendent and have also been organizing our layout tours.



My focus in the hobby has been on highly detailed and weathered structures. I find this hobby to be extremely interesting and challenging. With recent developments in digital technologies, we have seen a new level of realism. This has also reduced the amount of effort required and has created a real boost to the hobby.

I have enjoyed attending the SCWD meetings and have often been amazed at all of the information provided by the members and for the members. I would like to see the division continue to grow and develop and serve on the Board for another term.

John Kosobucki

As is often the story in model railroading, I was introduced to trains by my parents at Christmas time when I was 7 years old. The Lionel freight train set I received then is still operational, and occupies a 4 x 8 space in the basement along with a few accessories, scenery, and some upgrades. I was introduced to model railroad operations by the late Hank Brown when I was investigating a burglary to one of his properties, and he invited me to see his layout and become one of the regular operating crew. I



became an NMRA, and SCWD member in 1997.

We have some truly talented members of the SCWD, and I am utterly amazed at the detail and workmanship so many of them have accomplished on their layouts. I have been honored to operate on several of these layouts that belong to the best modelers I know.

Outside of the hobby, my professional life included 8 years as a journal clerk for the Wisconsin State Senate; 20 years as a deputy and sergeant for the Dane County Sheriff's Office; and 11 years as the site administrator for a national phone company that contracted with the Dane County Jail for inmate phone service.

As many of you have, I too have volunteered for many years at the SCWD Annual Train Show in Madison. It is great that so many of you have answered the call to make this annual event the success that it is. However, there is so much more that goes on behind the scenes for months and months leading up to this two-day event. Your SCWD BOD plays a significant role in making all of this happen.

I was honored when asked to throw my hat into the ring to run for a position on the SCWD Board of Directors. As the new guy, I know there will be a lot to learn, but I want to serve you, the members of the SCWD, and would be honored to have your vote.

Bill Mitchell

I became a member of the National Model Railroad Association sometime around 1967 and a LIFE member of the NMRA in 1988.



I was appointed to the Board of Directors of the South Central Wisconsin Division in April 2020 to fill a vacancy on the board due to a resignation. I volunteered to take the position of Clerk. I was elected to the Board of Directors at the next annual membership meeting in the Spring of that year.

I enjoy being a member of the SCWD Board of Directors and would like to be re-elected for the 2022 - 2023 term. If elected, I would be like to continue in the position of Clerk.

Steve Preston

Thank you for letting me sit on the board these past few years. I have learned a lot, and have enjoyed being part of our organization. I will continue to do my part for us all.



Thank you for your support.

Verona Senior Center
108 Paoli Street
Verona, WI 53593

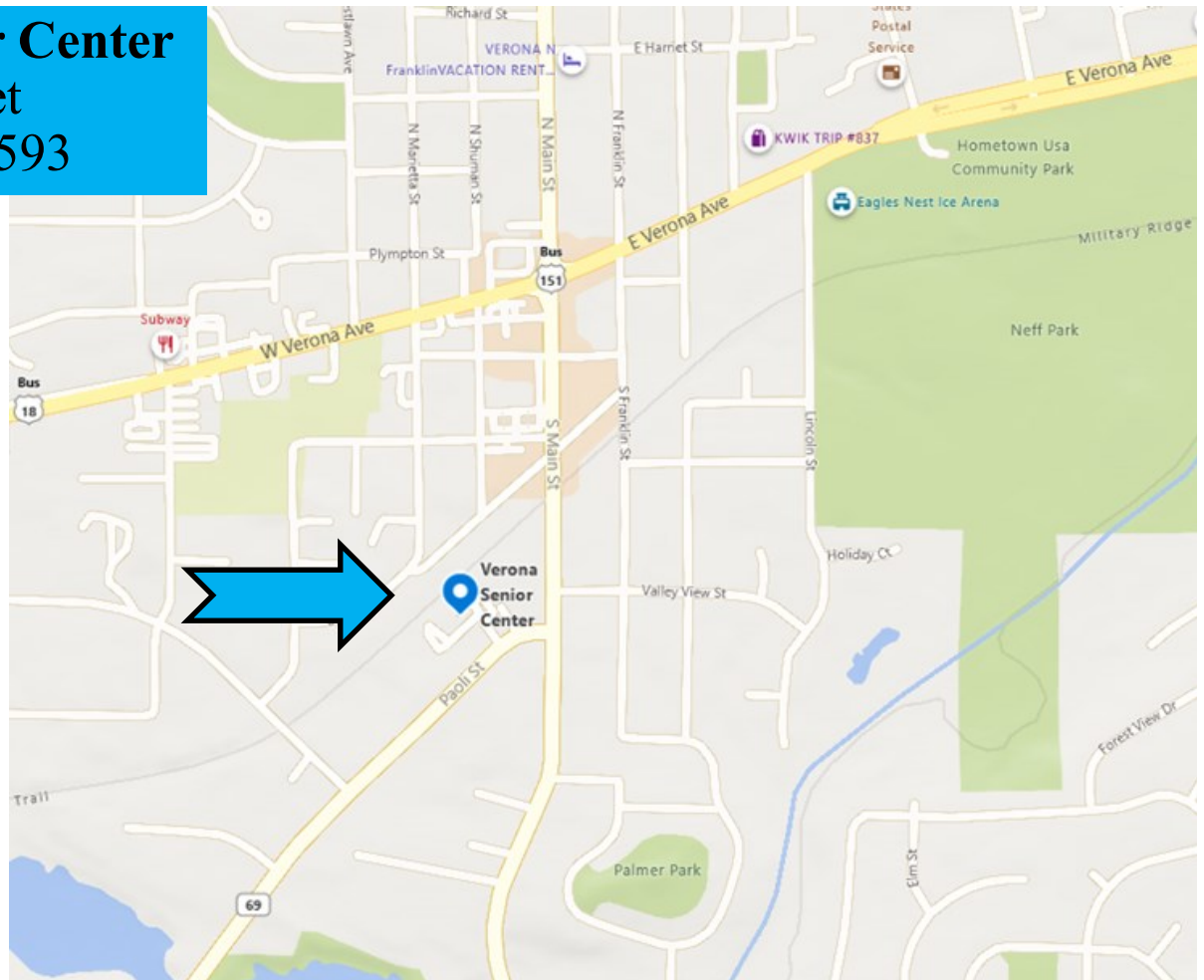

2021-2022 SCWD Video Contest

Steve Lanphear

Planning To Get Out Of Pandemic Jail This Summer And Do Some Railfanning Or Visit Some Layouts? You could enter some of your videos in this Contest!

SCWD 2021-22 Video Contest Guidelines

This year's SCWD video contest will be open for submitting entries on November 1, 2021.

Here are the things you need to know:

- There are two categories: **Prototype** and **Model**.
- The contest is open to those who attend the SCWD meetings.
- The person submitting an entry must be the one who took the video, however you may have help from others in editing your entry.
- The video can be from any time period (it doesn't have to be taken just to enter this contest).
- It has to be a **maximum** of 5 minutes in length, but can be any size less than that and the file has to be less than 2GB in size.
- All videos must be on a railroad or model railroad theme.
- The video can have title screen but not necessary, however there should be no names or identifiers on it (it is a "blind" contest).
- For the **Model Category**, the video can be of anyone's layout, not just your own.
- First, second and third place will be given for each category (no points given toward annual Photographer contest).
- **Deadline for Entries – March 1** (you will upload all entries to the website listed on the SCWD website, Video Contest webpage).
- You may enter more than once (max. of 5 entries per person).
- Voting starts **Mar 10** on the SCWD Video Contest webpage.
- Voting will be closed on end of day **April 15**.
- Winners will be announced at the May 2022 Meeting.

A Word about Constant Contact e-mail

Each Constant Contact e-mail includes links to update or unsubscribe your e-mail address. **Please do not use these links.** If you unsubscribe using the Constant Contact link, your e-mail address will be removed from the NMRA membership database, from the Midwest Region e-mail database and probably from your Division's records. If you get an e-mail that you don't want, just hit the delete key. Furthermore, if you use the update link, your change may not be timely posted to the NMRA membership database.

If you need to change your email address with the NMRA please follow these directions:

The direct way is to log on to the "Members" page of the NMRA website, choose the "View your NMRA membership" box on the right side of the screen, scroll down to the bottom of the page and select "Update". Enter the new email address in the appropriate box and click "Submit".

Fire Under the Rails

By Jim Feldman

Trains are at the mercy of the iron laws of metallurgy. Early experiments with strap iron, cast iron and others all failed because of it. After settling on steel, the issue seemed resolved, but the law is the law and steel isn't immune.

As strong, stable and workable as steel is, it expands when heated and shrinks when cooled, it's the law. With thousands of miles of rail lying exposed to the weather, this is bound to matter. Luckily, these two properties can be used to cancel each other out.

Extreme cold causes steel to shrink and this shrinkage can pull joints apart. On a long straight stretch this might not matter too much, but around curves and switches with their many delicate connections it can matter a lot.

Then there is the issue of snow and ice fouling the operation of switches.

In the brutal winter of 2019, Amtrak cancelled dozens of trips. Rails broke up and down the East Coast.

This problem has been known and understood since the middle 19th century and the solution has always been obvious: set the tracks on fire.

Fire heats switch points, melting the ice that fouls them. It also heats the rails and causes them to expand. Applied properly the expansion is enough to close the gaps opened by freezing or for crews to reconnect broken joints.

Over the years there have been different methods of getting this result. The earliest one was maintenance crews with two gallon buckets of "skunk oil" pouring it on the rails and tossing a match on it, this is rather like the smudge pots that citrus farmers use. The drawbacks are obvious. The fires are essentially uncontrolled, they are near wooden ties and often untrimmed undergrowth. Protocol requires notifying local fire departments of planned fires. Nobody wants local firefighters dumping water on frozen switches.

An old-style kerosene fire.



Crews using a firesnake to defrost tracks.
Firesnake is chemically impregnated rope laid in ten-foot section to heat rails.

More modern methods use built in electric, propane or natural gas heaters with blowers to direct the heat onto the switches and rails.



A Chicago yard after a round of controlled fires 2019.

The engineers among you might be wondering if this can all be avoided by careful design. Well, kind of.

Your first idea would be to take shrinkage into account when you designed and laid the track. They do that. Track is laid at what is known as neutral temperature defined for each location. Track is heated to the neutral temperature, and cools as it is laid. For example, the neutral temperature for Chicago is 70°F. The feds require recording the neutral temperature of each section of rail laid. A deviation of several degrees rarely has any effect. But as much as a hundred degrees below the neutral temperature can cause shrinkage capable of shearing connecting plate bolts or actually fracturing rails.

Alaska, Canada and Siberia have much different neutral temperatures in an attempt to minimize the problem in those very cold locations.

All these techniques and precautions are usually enough to keep the trains running but when temperatures hit -40°F or -50°F the laws of metallurgy take over.

Jim Feldman, SCWD Member



Congratulations to our Train Show Layout Winners



**Best in Show
Midwest Modutrak**



**First Place N Gauge
Milwaukee-N-Southeastern
(First year participant!)**



**Second Place N Gauge
Capital City N'Gineers**



**Third Place N Gauge
Chippewa Valley N-gineers**



**First Place Hi Rail/Garden
Ron Schlicht American Flyer Train**



**Second Place Hi Rail/Garden
Wisconsin Garden Railway Society**



**First Place HO
Wisconsin & Michigan Model Railroad Club**



**Second Place HO
Tamarack Creek Logging & Lumbar RR**



**Third Place HO
Fond du Lac Society of Model Railroad Hobbyists**



**First Place Z gauge
Wiz-Kidz**



**Second Place Z gauge
Royal Train**



**Special Recognition Award to
Madison HO Track
for over 50 years of contributing
to the success of the
South Central Wisconsin
Division
Rail Show and Sale**



Some of the (very happy) Train Set Winners

Photos by Mike Vivion



ON WITH THE SHOW!!!!









and just a few more taken by Ken Hojnacki.....



COMPANY STORE before and after, WOW!!



Madison HO Track assembly at their last show.....



and a module being taken to a new home



Marriott East, 7202 E 21st St
Indianapolis, IN 46219



Four Full Days
Three Regions
Two Day Train Show
One Convention
May 18-22, 2022

Clinics
Layout Tours
Ops Sessions
Prototype Tours



www.IndyJunction2022.org



RPM
CONFERENCE



20210506

A Puzzle for You

You like trains, or train watching, but have you ever wanted to go to an OPS (Operating Session) and run trains on someone else's layout, but were afraid you wouldn't know what to do?



Model Railroad Operation is a fun and interesting role-playing game where the players (operators) use model trains to simulate the movements of the prototype railroad. Operators fill the roles of railroad employees like engineers, conductors, yardmasters, dispatchers, and more. Many of our SCWD members participate each month at multiple layouts to enjoy this fun and stimulating practice of critical thinking and problem solving in the context of railroad operations.

Now, there is a way for you to get your feet wet in this critical thinking and problem-solving railroad environment in the privacy of your own home through the use of railroad switching puzzles.

In July 2020, a group of SCWD members started a project to introduce more of our members to the enjoyment of railroad operations, or as our wives call it, playing trains. Some of us have been engaged in operating sessions for 20 years or more, and would like to get more of you involved.

The project involves getting one to solve a series of train switching puzzles (on paper, or your computer) in the least number of moves possible. You can then submit your solution to see if yours was done in the least number of moves.

Beginners can start with **3 introductory puzzles** to show the kinds of skills used in railroad switching operations. Then, you can advance to a series of more advanced puzzles written and based on actual SCWD member area layouts. Or, if you have already been to an OPS session, you could do an introductory puzzle, and jump right into the more challenging ones.

Join the SCWD listserv now and begin learning what this is all about!

Email Steve Lanphear at scwdmemberlist@frontier.com to be added to the list and start receiving your puzzles now!

Happy Railroading!
Steve



Enjoy receiving interesting rail photos, model railroad tips, Operating puzzles, and challenging Mystery Photos??

Join The 120+ SCWD members and members from other Midwest Regional Divisions who are participating in the SCWD listserv. You can expect 5 - 10 photos of railfan photos or model railroad photos or other items per week on average, as well as SCWD announcements, monthly Mystery Photo contests, Modelers Corner, and OPS Corner Puzzles. The listserv has been running this since April 2012, and it has been quite popular.

The listserv is a one-way email broadcast to you, not a social media type service. The emails are sent in bulk, but as a BCC: type email.

Please save this email so you know how to get a hold of me. So, if you would like to try out this FREE member service, just send me your **Name** and **email address**, and **City/State** to the address below. You may drop out at any time by sending an email stating such to the same address below.

Steve Lanphear
SCWD listserv Coordinator
scwdmemberlist@frontier.com

OPS Puzzles

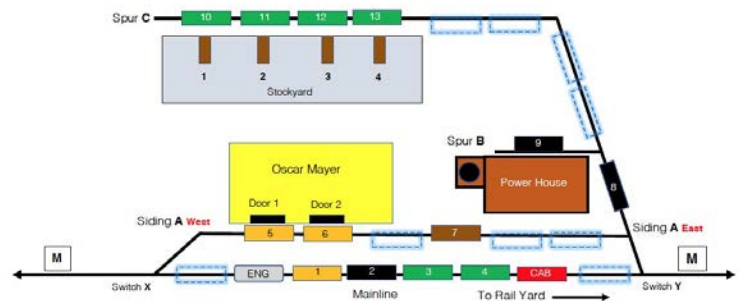

OPS Puzzles have arrived! We now have a section on the SCWD Website that has all 11 puzzles that we have published on the listserv, including the handouts and diagrams. You can start from the beginning, or pick and choose which puzzles you would like to try.

www.nmra-scwd.org/ops-puzzles.html

Steve Lanphear and the Puzzle Development Team.



**Minutes SCWD Board Meeting
7:00 pm, 10 January 2022
via Zoom meeting**



The meeting of the South Central Wisconsin Division Board of Directors was called to order at 7:00 pm by Superintendent Phil Hottmann. Phil Hottmann, Bob McGeever, Dr. Bill Clancy, John Kosobucki, Dave Down, Dave Dingman, Steve Preston, and Bill Mitchell were present.

***BOD Meetings:** Members of the SCWD are invited to join a Board of Directors meeting. Meeting dates are published in the **Bad Order**. Send a request to Phil Hottmann or another member of the SCWD Board for a ZOOM link to the upcoming meeting. The members' contact information is in the REDBOOK.*

Minutes

Motion by McGeever, second by Dingman, to approve the minutes of the December 13, 2021, meeting. Motion carried.

Paymaster Report

Bob McGeever presented the high points of the December Paymaster Report. Table sales for the February Mad City Train Show and Sale are approaching the budgeted income amount. Motion by Mitchell, second by Dingman, to approve the Paymaster Report as presented. Motion carried.

Committee Reports

Achievement Program - nothing to report.

Advertising - nothing to report.

Bad Order - Kathy, our Bad Order Editor, is always looking for more articles for the newsletter.

Special Note 1: The email list comes directly from the NMRA membership list, so please keep your membership active and your email current with the NMRA. All SCWD members are requested to inform the NMRA when their email address changes.

Special Note 2: Kathy, our newsletter editor, is always in need of articles. Please submit articles as soon as possible to have them included in the next publication of the Bad Order to SCWDKATHY@AOL.com via email with attachments in a WORD formatted document.

Clinics - Some possible clinics are being lined up for February.

Contests - Model and Photography - There was only one entry at the January membership meeting. The published schedule in the **Bad Order** is on track.

Modeling Project - nothing to report.

Door Prizes - SPECIAL NOTE - *The Door Prize Winners need to pick up their outstanding gift certificates in a timely manner. SEE NEW BUSINESS!*

Layout Tours - As of today, there are no February layout tours scheduled.

Our SCWD organization is always looking for more people to host virtual or in-person layout tours. Please contact Phil Hottmann about the possibility of opening up your layout for a virtual or in-person tour. Phil's contact information is in the REDBOOK.

Membership - The membership list is up to date.

Reminder - The National Model Railroad Association dues will increase in April. Renew your membership before April to save on your membership fee.

The current SCWD membership list is sent to Steve Preston on a monthly basis. The email address of the SCWD members associated with the membership list is used for the Constant Contact electronic communications system. Each member is responsible for making sure that their email address is valid. If someone has problems renewing their NMRA-SCWD membership using the ON-LINE systems, please contact Steve Preston. His contact information is in the REDBOOK.

Picnic - nothing to report.

Publicity - nothing to report.

Rail School - Our next Rail School will be held in January 2023. One switching layout is major disrepair and will be taken apart. The Rail School committee would like to have a new switching layout to replace this disassembled layout.

Rail Show - Social media and regular publicity is ready to start. Face masks will be required.

Website - www.nmra-scwd.org - The social media system will be leveraging our website.

The www.nmra.org website is *UNDERUSED* by its members. There is a direct link from our SCWD website to the National Model Railroad Association website. You will need to register your NMRA membership to view the "members only" information on the different pages of the NMRA website.

Old Business:

A motion was made by Dr. Clancy, second by Preston, to donate \$100.00 in the name of Fred Robinson (a member of the SCWD who passed away in November) to one of his designated organizations. Phil Hottmann will provide the name and address to Bob McGeever so the donation can be sent.

New Business:

Constant Contact - There was a discussion on some of the system's problems with meeting notices and email providers. Each problem will need to be addressed individually. At this time all members who are experiencing problems need to verify that the messages coming from the SCWD electronic mail are **NOT** being treated as **SPAM** or **BLOCKED** by the member's email provider.

Additional Constant Contact Account - The possibility exists that the SCWD may need to subscribe to another Constant Contact account to promote the February Train Show and Sale because our existing account does not allow for advertisements. A benefit of a new account will allow the train show committee to use the email addresses of people purchasing admission to the train show using credit cards. This account could also eliminate the postcard announcements.

Posting SCWD Clinics to YOUTUBE - This topic may be investigated after the February Train Show and Sale.

Banquet - Planning the banquet will begin after the February Train Show and Sale.

Door Prizes - Door prize gift certificates are not being picked up from the HOBBY STOP in a timely manner. A motion was made by Preston, second by Dr. Clancy, that beginning on March 1, 2022, all door prize gift certificates must be picked up from the HOBBY STOP in 3 months or the gift certificate will be forfeited. Motion carried.

Adjournment:

A motion was made by Kosobucki, second by Dr. Clancy, to adjourn the meeting. Motion carried. The meeting was adjourned at 7:58 pm.

Bill Mitchell - Clerk



Gateway 2022
NMRA National Convention
August 7-13, 2022
Marriott Grand, St Louis, MO
Information/Registration at gateway2022.org

MADISON HOBBY STOP

6622 Mineral Point Road, Madison, WI 53705

Ph: 608-829-3820 • Fax: 608-829-3852 • www.madisonhobbystop.com

Hours: Monday – Friday (10 am – 8 pm) and Saturday (10 am – 5 pm)

Model Railroading • Plastic Model Kits • Rockets & Accessories • Pine Car •
Paints • Tools & more!



**We still have a lot of winter left,
so keep working on the layout
and running trains.**

I have supplies in stock always.

We are closed on Sunday's starting March 6th till late November.

Bring on SPRING!!!!!!!!!!!!!!!!!!!!



**Preorders are 25% off regular price except
Walthers Proto which is 20% off**

New/old consignment coming in weekly, stop in for best selection

Remember, most model railroad items are 20% off

with a valid NMRA or other club id card

Excludes discounted or sale items, magazines, and consignments

Gift Certificates Available

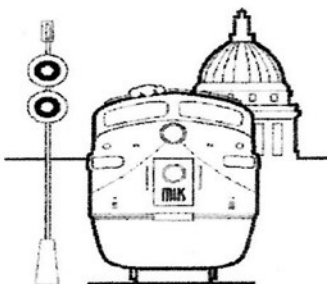

Madison Hobby Stop
Chris Roosli, Proprietor

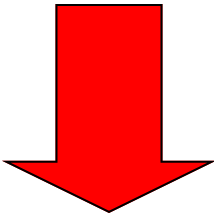

If you change your email address

don't forget to notify the NMRA and Kathy Clancy
Bad Order Editor

Thank you!

The Hobby Depot

Brian Stackpole, owner



See us on the web at: www.hobbydepotmonroe.com



835-17th Street
Monroe, Wisconsin 53566

Phone: 608-325-5107

Call ahead to be sure we're open!

email: hobbydpo@tds.net

TRAINS & MORE

South Central Wisconsin Division of the National Model Railroad Association

Publishes eleven issues yearly of the

BAD ORDER

Official Mailing Address:
BAD ORDER
3940 Trempealeau Trail
Verona, WI 53593

Photos in the Bad Order, unless otherwise noted,
are by Kathy Clancy

Deadline for submissions: **14th of the month
prior to publication.** Email Bad
Order Editor at SCWDKATHY@AOL.com



ADAIR SHOPS

Weight Upgrades for Improved Model Railroad Operation



Weight upgrade kits for
HO freight and passenger
cars (RTR and kits)



HO steel plate
and beam load kits

HO & N bridge kits



For a complete list of kits, along with additional
photos and sale items, visit our website.

www.adairshops.com

Adair Shops, PO BOX 344, Dyersville, IA 52040
adairshops@yousq.net

Place your ad here!!!

Contact

Kathy Clancy

Bad Order Editor

SCWDKathy@aol.com

PLEASE PATRONIZE OUR AREA HOBBY STORES

The Hobby Depot – 835 17th Street – Monroe WI
Madison Hobby Stop – 6622 Mineral Point Rd (inside Clock Tower) – Madison WI *

* = Train Show Ticket advance sales

SCWD 2021-2022 Meeting Schedule

Regular Meeting

BOD

Mar 6, 2022

Mar 14, 2022

Apr 3, 2022

Apr 11, 2022

May 1, 2022

May 9, 2022

June 13, 2022