

**November 2024**

**[www.nmra-scwd.org](http://www.nmra-scwd.org)**

**Volume 56 No. 3**

## **Super's Report**

Art Dawson  
Division Superintendent

Hello fellow modelers,

Fall is finally here and I've had to break out a jacket for the mornings. I'm traveling this month to northern Indiana for the Nickle Plate Historical and Technical Society's annual convention. We get to ride behind #765, a Nickle Plate Berkshire! I'm sure fun will be had.

While we lost Steve Stone last month, the WISE Division has lost John Tews, the major driving force behind Trainfest for many years. Amazing how we keep getting older.

I want to encourage you to participate in this year's modeling contest. These old passenger car kits are basically a box of sticks and a little bit of embossed metal. It's a big change from a box of molded plastic parts that go together in 15 minutes or less. It looks like fun! Please consider giving it a try. Be sure to see Mike Vivion at the next meet. This will be your final opportunity to sign up.

I'm still looking for a Rail School Chairman, or co-chair if you would be so kind as to lend a hand. We have a good pair of clinics lined up for the next meet, and are actively looking for someone to open their layout for viewing.

I'm looking forward to seeing all of you and enjoying our clinics, contests, and layout visits.

Art Dawson  
SCWD Superintendent  
Model railroading is fun!

**Next SCWD Meet**  
**Verona Senior Center, Verona**  
November 3, 2024 at 1 PM

**Next BOD Meeting:**  
November 12, 2024 at 6:30 PM  
ZOOM Meeting



**Next Youth Group**  
**Verona Senior Center, Verona**  
November 9, 2024 1 PM



# Clinic Column

Bob Wundrock

Thanks to Gary Saxton and your Clinics' Chair for their presentations at our September meet.

I had to fill in for Phil Hottman because of a Covid infection. I'll try to get Phil re-scheduled after the first of the year.

In November we'll be having Mark Vaughan from the Chicago area doing a clinic on Less than Car Load (LCL) freight and freight house operations.

Our second clinician will be George Bogatiuk from the decoder manufacturer Soundtraxx. George is the Product Expert at SoundTraxx and his tasks include handling retailer sales, the primary trade show booth attendant, assisting the engineering department in product improvement and product ideas, and assists the Support Department with overflow Customer Service requests and calls.

His clinic will be on the history of SoundTraxx, its Manufacturing process and the fact that they build decoders in Colorado. He'll review the products they offer and a brief demonstration of Blunami and the benefits of going that route.

See you virtually.  
Bob



## Model Railroad School

### Fun. Educational. Free.

Live demonstrations show you how to turn a toy train into an exciting, operating model railroad.

Kid's Make & Take Clinic: **free** freight car kit for kids\* that we help them assemble and run on our test track.

Sunday, January 5, 2025, 1–4 pm

Verona Senior Center, 108 Paoli St., Verona, WI

[www.nmra-scwd.org](http://www.nmra-scwd.org)

Hosted by the South Central Wisconsin Division of the National Model Railroad Association.  
\*While supplies last.

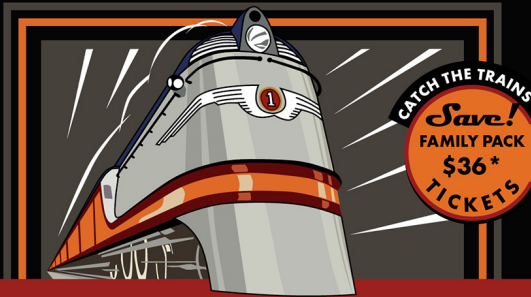

# MadCity

## MODEL RAILROAD SHOW & SALE

February 15–16, 2025  
Saturday 9–5 · Sunday 9–4  
Alliant Energy Center, Exhibition Hall  
Madison, Wisconsin

A GREAT FAMILY ENTERTAINMENT VALUE!

DISCOUNT TICKETS AVAILABLE AT [BIT.LY/MADCITYTRAINSHOW](http://BIT.LY/MADCITYTRAINSHOW)

\*Family Pack includes: two adults (regular/senior) & two kids (5–15). Kids under 5 FREE.



## MODEL RAILROAD SHOW

Sat. Feb. 15, 9AM–5PM • Sun. Feb. 16, 9AM–4PM • 2025

Alliant Energy Center, Exhibition Hall, Madison, WI

One of the Midwest's best model RR events showcasing beautiful model train layouts in Z, N, HO, S, O and G scale; classic toy trains; historical exhibits. **250+ vendor tables** of model train merchandise including tools, railroad collectibles, videos, books, clothing and artwork. Hourly door prizes for adults. Kids, age 5-15, can register to win an HO scale train set!

### FOUR HO TRAIN SETS GIVEN AWAY EACH DAY!

Family Pack \$36: two adults (regular or senior) and two kids (5–15)

Adults \$14 (16 & older), Seniors \$13 (65 & older)

Children \$6 (age 5–15), Kids under 5 FREE

Active duty military \$13. Two day pass \$18. Parking fee not included.

All children under 16 must be accompanied by an adult.

### Advance Sale Discount Tickets

Adults \$13 (16 & older), Children \$5 (age 5–15), Two Day Pass \$17



For more information:

[www.nmra-scwd.org](http://www.nmra-scwd.org)

Presented by the volunteers of the South Central Wisconsin Division of the National Model Railroad Association, Midwest Region

©2024, NMRA-SCWD





# Layout Tours

Phil Hottmann

I want to thank Bob Wundrock for setting up the tours for our October meeting. Unfortunately, I was not able to attend the tours due to Covid. From what I heard the tours were well attended. Thanks to Bob and John Mueller for opening both of their layouts.

If you have not seen John's layout it is spectacular, and I'm always amazed at the work Bob does given his limited dexterity.

It looks like we may not have any layout tours in November. There is a late Packer game so some people may want to get home to see the game.

I'm always looking for new layouts or ones with recent work. I know there are a number of layouts being started or being worked on. I'm looking forward to the opportunity to get these on the schedule. If you would like to be open for the November meeting, I could still get you scheduled. Or if you would like to be on the schedule in February or next season please let me know.

Phil



John Mueller



Bob Wundrock

# Youth Group

Steve Preston, Chair



At the Youth Group meeting this month, Phil Hottmann showed the kids how to use DCC on their layouts. We had each kid bring a DCC engine if they had one and a smart phone. Phil and Karl Hauth set up a large straight rail yard at one end and a large loop on another. Then they were shown how to download an app to their phone and use it to control their engines. They had to pick up cars and drop off cars using their smart phones. They had a blast, they each took turns using their engines on their app on the phone to make their engines sing and dance as they ran down the track.

Thanks to Phil, Karl and Chris Bradley for your help on making this session a great one.

Steve Preston  
Youth Group Chair and  
Membership Chair



# Contest Column

Dave Down, Chair

If your entry into the fall has been disappointing because the sports teams you like to follow have not been doing so well, never fear. Now you won't be distracted from the really important things in life, like your model railroad infatuation. As we work our way through the fall and winter months, our hobby addiction will help us ignore the weather (when it needs to be ignored), to turn off the TV when the political ads get to be too much, and to distract us from sports teams that can't seem to get out of their own way.

For our next contest we are going to look at specialty cars. In this case, model cars that are souvenirs of tourist trains, museums and other organizations. The theme for November 3 is:

## Souvenir Cars

- A. tourist train car
- B. convention car
- C. model RR club or historical society car
- D. museum car

## A quick heads-up for the December contest.

We are going to be repeating a contest from a few years ago called Photo Match. This contest will be only of models which have been made to match a photograph. It can be a picture you took or a picture you found, but the picture will need to come with the model. There will be no photo contest in December.

## October 6 Popular Vote Contest Results — Freight Station

### Models

Cat. A Stand Alone Freight Building

- 1st Don Swinton: D B & S Freight station
- 2nd Sean Hadfield: Bachman Kit
- 3rd Jason Martin: blue and white modern freight house



Cat. B Freight / Passenger Combination Building

- 1st Don Swinton: Combo station
- 2nd Sean Hadfield: Walworth station



Cat D. Open Freight Platform (with or without office)

- 1st Don Swinton: Open wood platform



### Photos - Prototype

Cat. PA Stand Alone Freight Building

- 1st: David Down: Norfolk Southern Freight terminal in Mobile, AL
- 2nd David Down: Belleville WI Freight House

### Photos - Models

Cat. MA Stand Alone Freight Terminal

- 1st David Down: Water Street Freight station

Dave



# Modeling Project

Mike Vivion



As I write this column, we have 12 people signed up as participants for this year's modeling project. Your last chance to sign up will be on November 3rd. I still have plenty of the Walthers HO car kits so you still have a choice of the various passenger styles to choose from. I have not had time to get the rules published on our website, but they are basically as follows:

Rules for the project are that you must be an NMRA member, must build one of the Walthers passenger car kits as part of a mini-diorama that is no larger than 160 x 160 scale feet in size. For HO scale this space is approximately 2 square feet. The mini-diorama does not have to include railroad track. The mini-diorama may also include structures, vehicles, figures, other scenery items (shrubs, turf, grass, etc.), etc. as you prefer. The passenger car can be built as an "abandoned" car or as converted into some kind of business (for example, a diner, gas station, hobby shop, or other retail business) or even as an "abode" that someone is using as housing.

A \$10 deposit is required for you to receive your passenger car kit. Last chance to sign up is at the November SCWD meeting. The deposit will be refunded if you bring the finished mini-diorama for entry into our popular vote contest at the April 2025 SCWD meeting. We will be offering 1st, 2nd and 3rd place prize categories again this year.

Note, to those who have been virtually attending SCWD meeting, you can participate in this project as well. Simply contact Mike Vivion not later than October 30, 2024, via email or phone to work out the details. Mike's contact information is in the SCWD Red Book.

I know this year's project uses only HO car kits, but you are welcome to participate regardless of what scale you model in personally. I hope trying something a little different from the past few years of our modeling projects will be appealing to you and that more of you will choose to sign up and participate.

Mike Vivion  
Modeling Project Chair



**Announcing the Cincinnati Division 7's  
limited-edition, HO scale,  
N&W HC-46 ACF 2-Bay Covered  
Hopper cars  
that we have for sale.**

**This car is unique in that it is a repaint scheme  
with patched-out data.**

The following link provides details about it as well as  
pricing, shipping and ordering information.

[https://division7mid-  
centralregionnmra.godaddysites.com/car-projects](https://division7mid-centralregionnmra.godaddysites.com/car-projects)

*Paul Maciulewicz*

NMRA; MCR; Cincinnati Division 7  
Car Projects Chairman



## FAMILY FUN AT ARCTIC RUN

**Saturday-Sunday,  
January 11-12, 2025**

**27th Arctic Run Model Railroad Show & Sale.** A fun filled family event featuring activities for children as well as adults. Operating model train layouts, exhibitors, and vendors from throughout the upper Midwest will be on hand to entertain, answer questions and sell you the latest in model railroading fun. Saturday, 9 AM – 5 PM, Sunday, 10 AM – 3 PM, Stevens Point Holiday Inn and Convention Center, 1001 Amber Avenue, Stevens Point.

Adults \$5.00, \$2.00 age 12-17. Children 11 and under are **FREE**.

For information call  
Jim Miller (715) 340-0265,  
[jimb67@gmail.com](mailto:jimb67@gmail.com) or  
Don Anderson (715) 340-8105,  
[cwnr\\_mnw@yahoo.com](mailto:cwnr_mnw@yahoo.com).

## A Puzzle for You

You like trains, or train watching, but have you ever wanted to go to an OPS (Operating Session) and run trains on someone else's layout, but were afraid you wouldn't know what to do?



Model Railroad Operation is a fun and interesting role-playing game where the players (operators) use model trains to simulate the movements of the prototype railroad. Operators fill the roles of railroad employees like engineers, conductors, yardmasters, dispatchers, and more. Many of our SCWD members participate each month at multiple layouts to enjoy this fun and stimulating practice of critical thinking and problem solving in the context of railroad operations.

Now, there is a way for you to get your feet wet in this critical thinking and problem-solving railroad environment in the privacy of your own home through the use of railroad switching puzzles.

In July 2020, a group of SCWD members started a project to introduce more of our members to the enjoyment of railroad operations, or as our wives call it, playing trains. Some of us have been engaged in operating sessions for 20 years or more, and would like to get more of you involved.

The project involves getting one to solve a series of train switching puzzles (on paper, or your computer) in the least number of moves possible. You can then submit your solution to see if yours was done in the least number of moves.

**Beginners** can start with **3 introductory puzzles** to show the kinds of skills used in railroad switching operations. Then, you can advance to a series of more advanced puzzles written and based on actual SCWD member area layouts. Or, if you have already been to an OPS session, you could do an introductory puzzle, and jump right into the more challenging ones.

**Join the SCWD listserv now and begin learning what this is all about!**

Email Steve Lanphear at [scwdmemberlist@mhtc.net](mailto:scwdmemberlist@mhtc.net) to be added to the list and start receiving your puzzles now!

Happy Railroading!  
Steve



**Enjoy receiving interesting rail photos, model railroad tips, Operating puzzles, and challenging Mystery Photos??**

Join The 120+ SCWD members and members from other Midwest Regional Divisions who are participating in the SCWD listserv. You can expect 5 - 10 photos of railfan photos or model railroad photos or other items per week on average, as well as SCWD announcements, monthly Mystery Photo contests, Modelers Corner, and OPS Corner Puzzles. The listserv has been running this since April 2012, and it has been quite popular.

The listserv is a one-way email broadcast to you, not a social media type service. The emails are sent in bulk, but as a BCC: type email.

Please save this email so you know how to get a hold of me. So, if you would like to try out this FREE member service, just send me your **Name** and **email address**, and **City/State** to the address below. You may drop out at any time by sending an email stating such to the same address below.

Steve Lanphear  
SCWD listserv Coordinator  
[scwdmemberlist@mhtc.net](mailto:scwdmemberlist@mhtc.net)



## OPS Puzzles

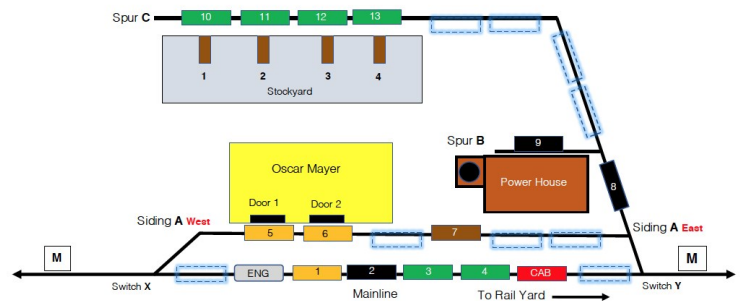

OPS Puzzles have arrived! We now have a section on the SCWD Website that has all 11 puzzles that we have published on the listserv, including the handouts and diagrams. You can start from the beginning, or pick and choose which puzzles you would like to try.

[www.nmra-scwd.org/ops-puzzles.html](http://www.nmra-scwd.org/ops-puzzles.html)

Steve Lanphear and the Puzzle Development Team.



**Verona Senior Center**  
108 Paoli Street  
Verona, WI 53593

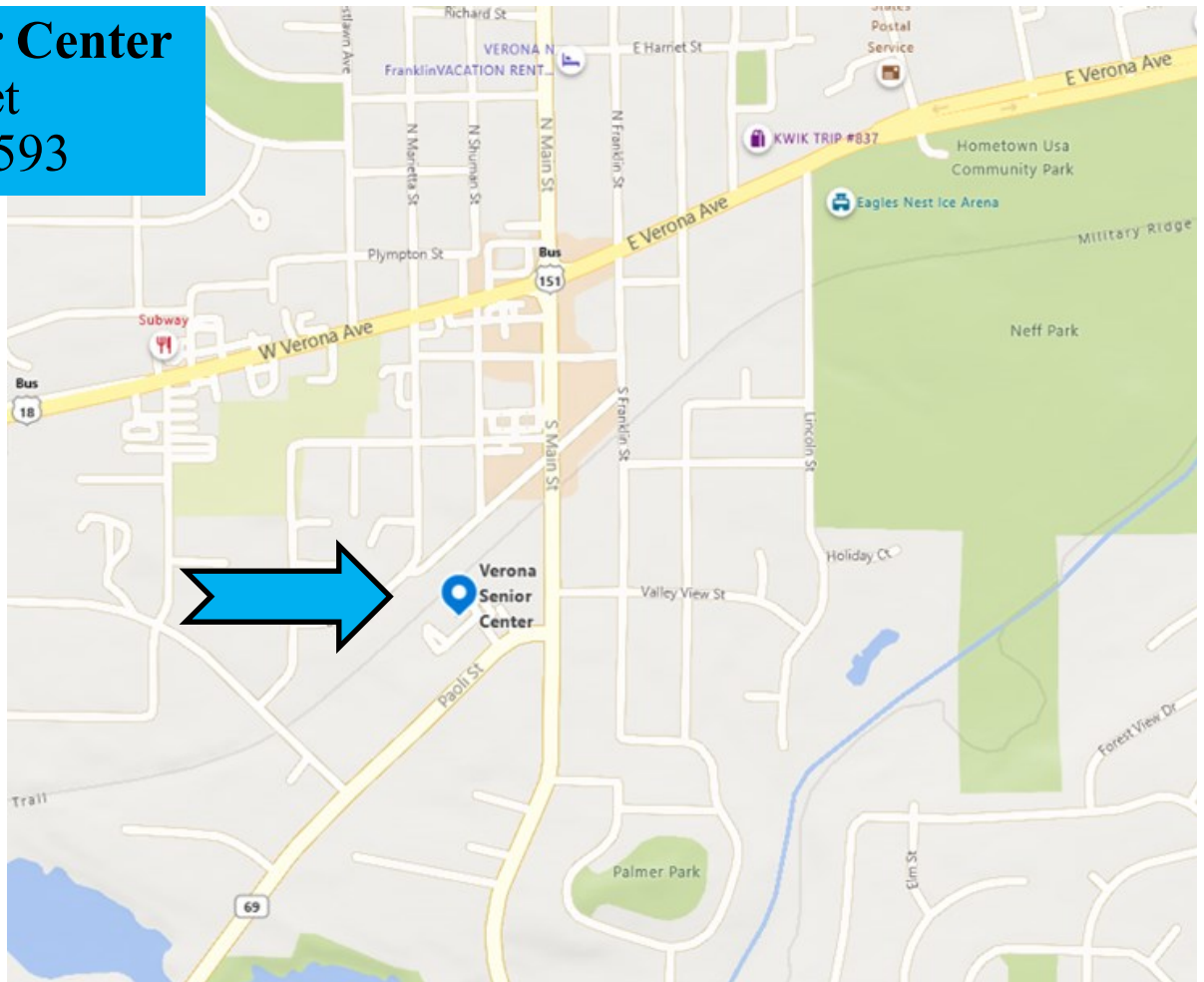



# NMRA NEWS



**July 14 – 19, 2025**  
[www.nmra2025.org](http://www.nmra2025.org)

**Big 2 day  
National Train  
Show!**

**NMRA National  
Convention**

**STATION No. VI**

**2025  
NMRA**

**Novi, MI**

**CELEBRATING 90 YEARS**

## **STATION No. VI NMRA National Convention**

Barrie Hensel

Station No. VI publicity chairman

Hello NMRA members! The 2024 NMRA National Convention is complete and the 2025 National convention

– **STATION No. VI** –

is heading down the track at full steam ahead!

Registration is open and we already have over 100 registrations.

Go to

[\*\*nmra2025.com\*\*](http://nmra2025.com)

to see all of the event details and the registration page.





## Minutes SCWD Board Meeting September 10, 2024 via Zoom meeting



The meeting of the South Central Wisconsin Division Board of Directors was called to order at 7:17 pm by Superintendent Art Dawson. Art Dawson, Bob McGeever, Dave Dingman, Dave Down, and Bill Mitchell were present. Phil Hottmann was unable to attend. Bob Wundrock - Clinics Chairperson, and John Haverberg - Picnic Chairperson, were also in attendance. (Meeting date and start times may vary due to BOD members schedules.)

**BOD Meetings:** Members of the SCWD are invited to join a ZOOM Board of Directors meeting. Meeting dates are published in the **Bad Order**. Send a request to Art Dawson or another member of the SCWD Board for a **ZOOM** link to the upcoming meeting. The members' contact information is in the **RED BOOK**.

### Minutes

Motion by McGeever, second by Dingman to approve the minutes of the SCWD Board Meeting held on August 20, 2024. Motion carried.

### Paymaster Report

Bob McGeever presented the highlights of the August Paymaster Report and some minor changes to the 2024 - 2025 SCWD Budget. Motion by Dingman, second by Preston, to approve the Paymaster Report. Motion carried.

### Committee Reports

**Picnic** - John Haverberg provided an update on the July picnic held at Little Amerricka in Marshall. The application for funds from the National Model Railroad Association member retention program has been approved. Plans are for the same caterer to cater the picnic for our July 2025 picnic. The National Model Railroad Association 2025 NMRA National Convention will be held in Novi, Michigan, on July 14 - 19. Many of our SCWD members plan on attending the 2025 convention. A motion to hold our Summer Picnic at Little Amerricka in Marshall on July 12, 2025, was made by McGeever, second by Preston. Motion carried.

**Achievement Program** - Nothing to report.

**Advertising** - Nothing to report.

**Bad Order** - Articles have been submitted for the newsletter by September 18.

*Special Note 1: The email list comes directly from the NMRA membership list, so please keep your membership active and your email current with the NMRA. All SCWD members are requested to inform the NMRA when their email address changes.*

*Special Note 2: Kathy, our newsletter editor, is always in need of articles. Please submit articles as soon as possible to have them included in the next publication of the Bad Order to SCWDKATHY@AOL.com via email with attachments in a WORD formatted document.*

**Clinics** - Bob Wundrock - ZOOM presentations are working very well. The clinics for October and November are lined up.

**Contests - Model and Photography** - Dave Down is looking for ideas on the **TRAIN MAINTENANCE** categories for an upcoming contest.

**Modeling Project** - Mike Vivion - The old HO passenger car kits distributed at the September 8 membership meeting. Kits will also be available at the October 6 meeting. Every kit has a cost of \$10.00 that will be refunded if the completed diorama is submitted for the April 2025 contest.

**Door Prizes** - Gift Certificates to **MADISON HOBBY STOP** have been purchased for the remainder of 2024. More gift certificates will be purchased for the 2025 SCWD Membership meetings when needed.

**Layout Tours** - Nothing to report. (Phil Hottmann has a few openings for layout tours for the SCWD 2024 - 2025 season.)

*Our SCWD organization is always looking for more people to host virtual or in-person layout tours. Please contact Phil Hottmann about the possibility of opening up your layout for a virtual or in-person tour. Phil's contact information is in the RED BOOK.*

**Membership** - Steve Preston reported the membership renewals are current.

*The current SCWD membership list is sent to Steve Preston on a monthly basis. The email address of the SCWD members associated with the membership list is used for the Constant Contact electronic communications system. Each member is responsible for making sure that their email address is valid. If someone has problems renewing their NMRA-SCWD membership using the ON-LINE systems, please contact Steve Preston. His contact information is in the RED BOOK.*

**Spring Banquet** - Nothing to report.

**Publicity** - A discussion on FACEBOOK advertising will continue during the October Board of Directors meeting.

**Rail School - January 5, 2025** - Someone is still needed to coordinate the Rail School for January 2025. *Hopefully, someone will volunteer to be the coordinator at the October membership meeting. Help will be needed for the January Rail School. Ideas are appreciated.*

**Rail Show** - The *57th Madison Model Railroad Show and Sale* will be held on February 15 - 16, 2025. Vendor table reservations are coming in. A few layouts are scheduled. The vendors and exhibitors enjoy our show. Dave Down: "Volunteers are a key to our Rail Show success".

*Peter Wigglesworth has retired from the Rail Show Unloading / Loading Coordinator position. A new Friday and Sunday Rail Show Unloading / Loading Coordinator is needed to replace Peter.*

**Youth Group** - Steve Preston - A small number of Youth Group members attended the Illinois Railroad Museum on Saturday, August 24. Steve is looking at visiting the National Railroad Museum in Green Bay and the Mid-Continent Museum in North Freedom in 2025. The September 14 Youth Group meeting at the Verona Senior Center has been canceled. Most of the meeting coordinators will be unable to attend. DCC systems and components will be presented at some of our youth group meetings.

**Special Note:** Those SCWD members who have DCC systems may wish to be involved with the review. Contact Steve Preston, Phil Hottmann, or Chris Bradley - contact information is in the RED BOOK.

*Youth Group Notes: Youth 18 years of age and under are welcome to join the SCWD Youth Group. A parent or designated adult is required to attend with the youth. The Youth Group Committee is looking for more members. Also, SCWD members are needed to present model railroading topics.*

**Website** - The website looks to be in good order

**Social Media** - Nothing to report.

**Old Business:**

Nothing to report.

**New Business:**

Please think about our SCWD members who should be recognized at the 2025 Spring Banquet for their involvement with the South Central Wisconsin Division activities.

**Adjournment:**

A motion was made by McGeever, second by Dingman, to adjourn the meeting. Motion carried. The meeting was adjourned at 8:01 pm.

**Bill Mitchell** - Clerk



**For those members that participate in the listserv emails from Steve Lanphear, please remember to send him your new email if you change it! Changing your email with the NMRA does not change it on the listserv. His email is:**

Steve Lanphear  
SCWD listserv Coordinator  
scwdmemberlist@mhtc.net

**FROM the NMRA  
Please Keep in Touch**



Please make sure the NMRA has your current contact information. You will not be able to access the full range of NMRA benefits unless we can reach you.

- Please visit [nmra.org/members](https://nmra.org/members)
- Use your email address and password to log in.
- If you have not yet registered, or forgot your password, there are buttons for that. Take a moment to easily correct any problems.
- Once logged in, click on Member Info (top right corner).
- Make sure your information is correct.
- If not, please go to:

[nmra.org/request-membership-info-changes](https://nmra.org/request-membership-info-changes)

to submit a request for changes to be made.

*Thank you!*





# MADISON HOBBY STOP

6622 Mineral Point Road, Madison, WI 53705

Ph: 608-829-3820 • Fax: 608-829-3852 • [www.madisonhobbystop.com](http://www.madisonhobbystop.com)

**Hours: Monday – Friday (10 am – 8 pm) and Saturday (10 am – 5 pm)**

Model Railroading • Plastic Model Kits • Rockets & Accessories • Pine Car •  
Paints • Tools & more!

**The outside work is coming to an end,  
which means more time to work  
indoors on the layout!**



**New items starting to come in and new/old stock  
is always coming in, shelves are full!!**

**Starting Sunday December 1st we will be open  
Sunday's 12:00-5:00 thru February**



**Preorders are 25% off regular price except  
Walthers Proto which is 20% off**

**New/old consignment coming in weekly, stop in for best selection**

**Remember, most model railroad items are 20% off  
with a valid NMRA or other club id card**

*Excludes discounted or sale items, magazines, and consignments*

**Gift Certificates Available**

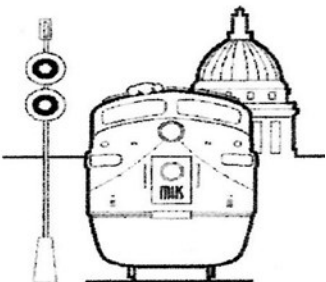

Madison Hobby Stop  
Chris Roosli, Proprietor

# The Hobby Depot

Brian Stackpole, owner



See us on the web at: [www.hobbydepotmonroe.com](http://www.hobbydepotmonroe.com)



835-17th Street  
Monroe, Wisconsin 53566

Phone: 608-325-5107

Call ahead to be sure we're open!

email: [hobbydpo@tds.net](mailto:hobbydpo@tds.net)

**TRAINS & MORE**

## South Central Wisconsin Division of the National Model Railroad Association

Publishes eleven issues yearly of the

### **BAD ORDER**

Official Mailing Address:  
BAD ORDER  
3940 Trempealeau Trail  
Verona, WI 53593

Photos in the Bad Order, unless otherwise noted,  
are by Kathy Clancy

Deadline for submissions: **14th of the month  
prior to publication.** Email Bad  
Order Editor at [SCWDKATHY@AOL.com](mailto:SCWDKATHY@AOL.com)

Place your ad here!!!

Contact

Kathy Clancy

Bad Order Editor

[SCWDKathy@aol.com](mailto:SCWDKathy@aol.com)

# Railroad Collectibles

## **Wanted to Purchase:**

Annual Passes-Card size-Pre 1830

Annual Reports

Brochures-Railroad Brochures, Folders, Booklets

Calendars-Pre-1980 Railroad Issued

Depot Related Items: Telegraph-Telephone-Signs-  
Ticket Dater Machines-W/Brass Die Insert

Diagram Books-Locomotive-Freight-Passenger

Dining Car China-Silverware-Holloware-Glassware

Especially With Railroad Name, Initials,  
Logo

Engineering Data Books-Track Charts-Blue Prints

Great Lakes Car Ferry and Passenger Lines-

Passenger Service Memorabilia

Fred Harvey Restaurant Items-Dishes, Glass, Silver,  
Paper and any Miscellaneous Items

Locomotive Builder Plates

Miscellaneous-Many more items not mentioned

Publications-RR Historical Societies-RR Employee  
Magazines

Signs-Porcelain or Metal with Railroad Logo

Step Boxes-with RR Name/Logo

Timetables-Public and Employee Railroad Sched-  
ules

Wax Sealers-From Railroads or Express Companies

Model Railroad Items: HO Gauge-Brass Equip-  
ment O Gauge (2 Rail 1/4" scale), Brass

Equipment, Kits, Passenger and Freight

## **NOT BUYING:**

No Model Railroad Magazines

No Insulators, Date Nails, Tokens, Post Cards,  
Watches or Belt Buckles

**RAILROAD RELICS**  
**LARRY BUNCE**  
**201 NORTH KERCH ST.**  
**BROOKLYN, WI 53521**  
**(608) 455-4233**

EMAIL: [rrrellmb@charter.net](mailto:rrrellmb@charter.net) or  
[rrrellmb@gmail.com](mailto:rrrellmb@gmail.com)

**\*\*BUY\*\*Shows-Ebay\*\*SELL**

## PLEASE PATRONIZE OUR AREA HOBBY STORES

The Hobby Depot – 835 17<sup>th</sup> Street – Monroe WI  
Madison Hobby Stop – 6622 Mineral Point Rd (inside Clock Tower) – Madison WI \*

\* = Train Show Ticket advance sales

### SCWD 2024-2025 Meeting Schedule

#### Regular Meeting

November 3, 2024  
December 1, 2024  
January 5, 2025 - Rail School  
February 2, 2025  
March 2, 2025  
April 6, 2025

#### BOD

November 12, 2024  
December 10, 2024  
January 14, 2025  
February 11, 2025  
March 11, 2025  
April 15, 2025

#### Youth Group

November 9, 2024  
December 14, 2024  
January 11, 2025  
February 8, 2025  
March 8, 2025  
April 12, 2025

### A Word about Constant Contact e-mail

Each Constant Contact e-mail includes links to update or unsubscribe your e-mail address. **Please do not use these links.** If you unsubscribe using the Constant Contact link, your e-mail address will be removed from the NMRA membership database, from the Midwest Region e-mail database and probably from your Division's records. If you get an e-mail that you don't want, just hit the delete key. Furthermore, if you use the update link, your change may not be timely posted to the NMRA membership database.

#### **If you need to change your email address with the NMRA please follow these directions:**

The direct way is to log on to the "Members" page of the NMRA website, choose the "View your NMRA membership" box on the right side of the screen, scroll down to the bottom of the page and select "Update". Enter the new email address in the appropriate box and click "Submit".