

Organic Link is the ideal product for places of retreat, informal team meetings and elegant waiting areas. The optional privacy panels offer visual and acoustic protection from the open room. The elements can be combined in a straight line to create a bench of potentially unlimited length.

INFINITE POSSIBILITIES

Organic Link



- ERGONOMIC
- EXECUTIVE
- CONFERENCE ROOM
- MULTI-PURPOSE
- LABTEK
- LOUNGE AND WAITING ROOM

Organic Link

TECHNICAL SPECIFICATIONS

- 15 models with the following configurations:
 - 3 benches
 - 3 benches with backrest
 - 7 types of privacy panels allowing for visually and acoustically isolated spaces
 - 2 tables
- Large selection of table colors and finishes, made of particule board or phenolic resin
- Seat and backrest made of plywood with cushions of high resilience polyurethane slab foam
- Frame made of steel (2" x 3/16"), finished with metallic silver paint
- Connectivity module with electrical and USB outlets
- Plastic glides

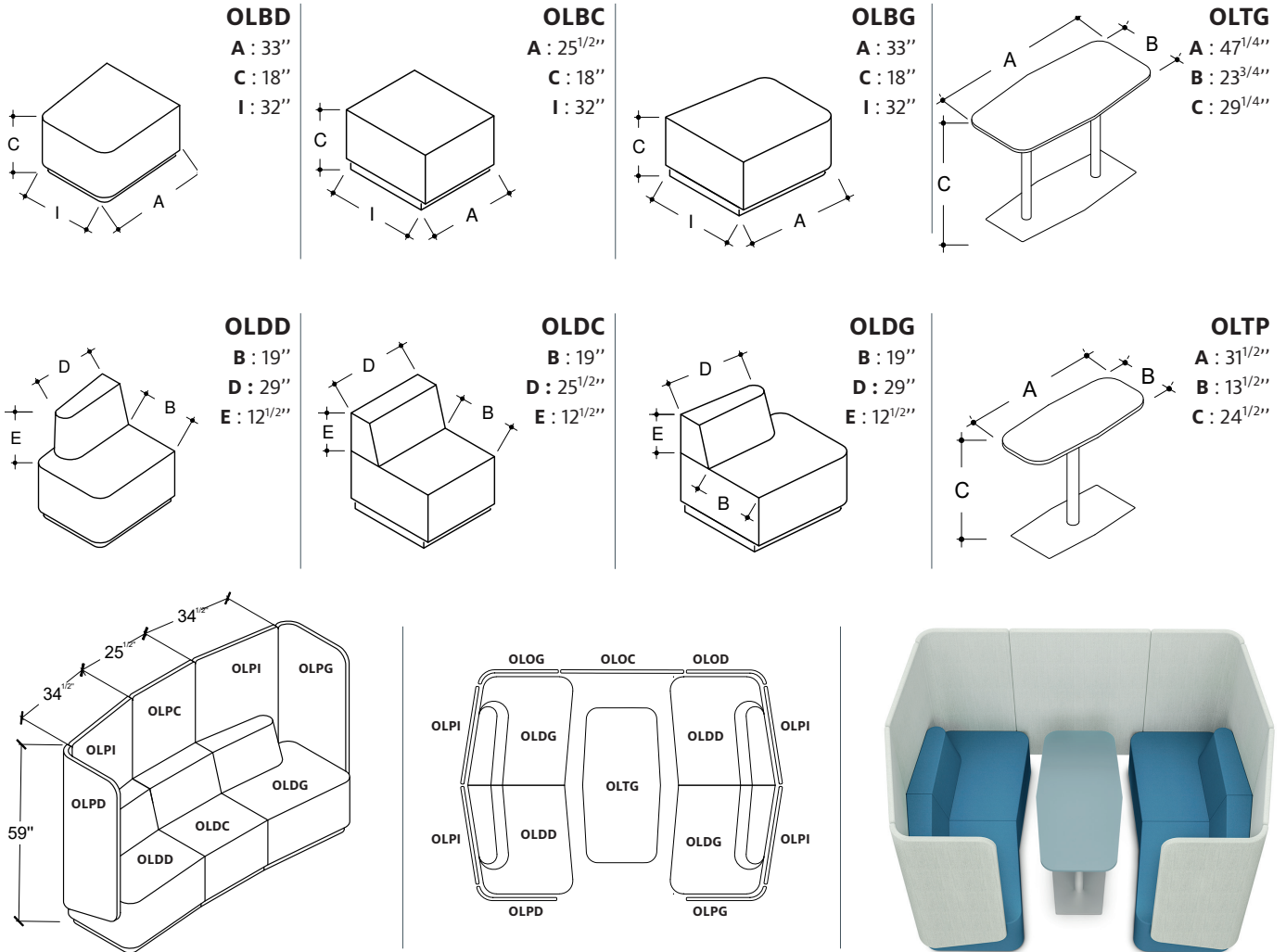

Comfort at work

10871, avenue Salk
Montréal-Nord (Québec) H1G 6M7
T 514.324.0916 • 800.982.6889
F 514.324.2335

bouty.com

