

FOR TANKS 48" X 133"

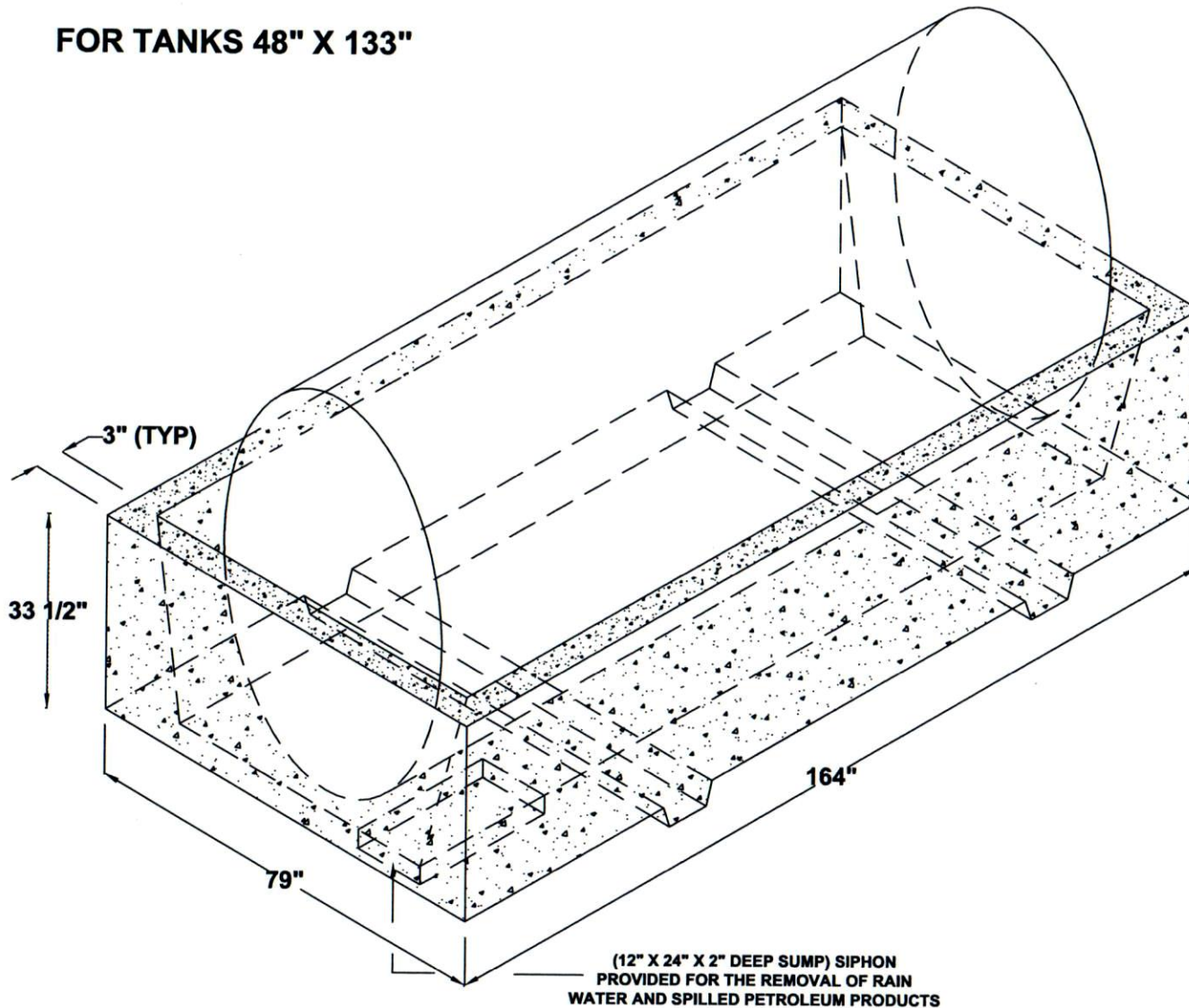

GROVE CONCRETE & SUPPLY, INC.
 18426 DURAND AVENUE P.O. BOX 363
 UNION GROVE, WISCONSIN 53182
 (262) 878-2030 FAX (262) 878-4222
 GroveConcrete.com

NOTES:

1. REINFORCED CONCRETE 4,000 PSI MIN.
2. WALLS & FLOOR REINFORCED WITH #4 REBAR ON 12" CENTERS.
3. FLOOR 5" THICK.
4. WALLS TAPER FROM:
3" AT TOP TO 6" AT BTM.
5. BTM. I.D. DIM. ARE 67" X 152".

1,000 GAL. HAZARDOUS CHEMICAL & FUEL CONTAINMENT VESSEL

FOR ANY MODIFICATIONS CALL GROVE CONCRETE

DRAWN BY: RAY DATE: 12/20/13

SCALE: EST. WEIGHT: VERSION:
NTS 12,500 LBS. 00001

DWG. # SHEET 1 OF 2
CON-1000-1

THIS DRAWING AND THE INFORMATION CONTAINED HEREON IS THE EXCLUSIVE PROPERTY OF GROVE CONCRETE & SUPPLY, INC., AND SHALL NOT BE REPRODUCED, USED, OR DISCLOSED TO OTHERS EXCEPT AS AUTHORIZED THROUGH WRITTEN CONCENT FROM GROVE CONCRETE & SUPPLY, INC.