

# INSTALLATION INSTRUCTIONS

## HONEYCOMB SHADES

### Skylight with **SIMPLICITY MOTORIZATION**



Thank you for your purchase. This shade has been custom built for you from the highest quality materials. To avoid errors and save valuable time, please read these instructions before installing your new shade.



## TOOLS YOU WILL NEED

1. Pencil or Marker
2. Measuring Tape
3. Phillips Screwdriver
4. Carpenter's Level
5. Power Drill
6. Mounting Fasteners



Mounting Surface	Fastener
Drywall, Plaster	Wall Anchors, Expansion Bolts (Not Provided) 
Metal	Sheet Metal Screws (Not Provided) 
Wood	No. 6 Hex Head Screws (Provided) 

# GETTING STARTED

All the required installation components are wrapped in your package along with these instructions. Check that the parts you have correspond to the parts shown below. ***NOTE:*** *Some parts may vary depending upon your mounting option.*

## PARTS

- Installation Brackets .....



- Battery Wand Clip (headrail) .....

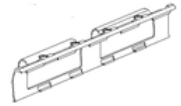

- Battery Wand Clip (wall mount) .....



- Screws .....



## BRACKET & BATTERY PACK PLACEMENT

This application **MUST** be installed as an Inside Mount

Make sure that the battery wire will be able to reach the motor.

There is a minimum of 2-3/4" needed from the back of the bracket to the front of the window opening.

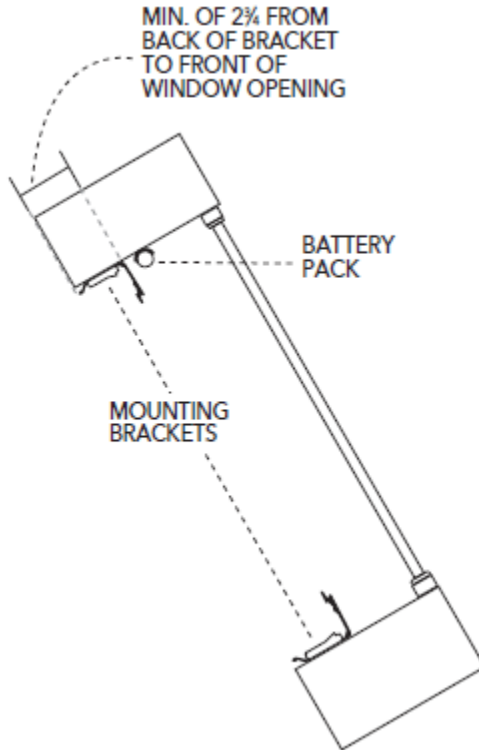

## INSTALLING THE BRACKETS

Shades are shipped with the required number of brackets for proper installation. End brackets should be located approximately 3" from either end.

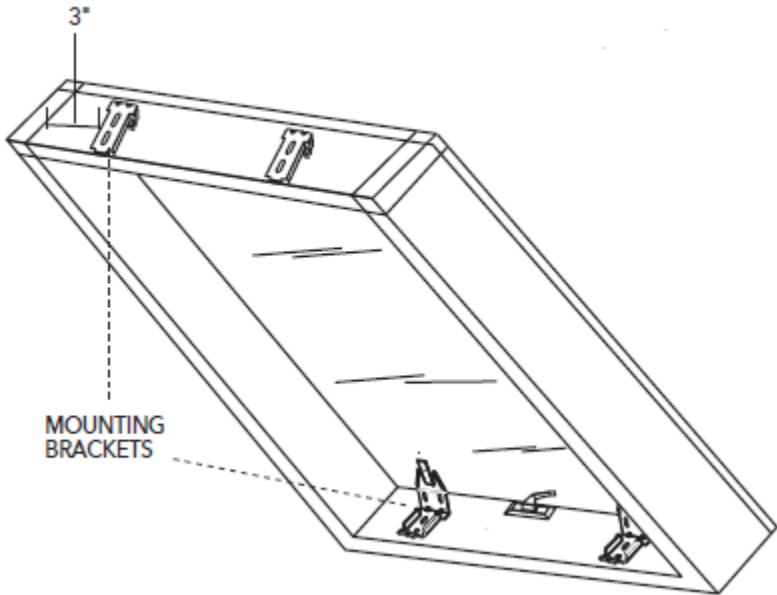

Depending on the width of the shade, additional brackets may be necessary, evenly spaced between the two end brackets.

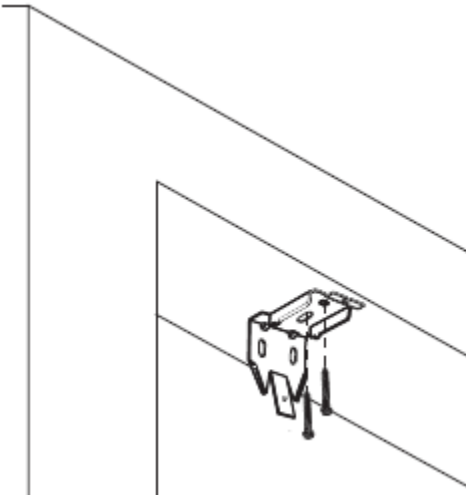

Using the mounting bracket as a template, measure to the edge of the bracket and mark the hole locations with a pencil for drilling. When mounting brackets, make sure they are in line with each other.

## INSTALLING THE BATTERY PACK

Battery Pack - Attach the battery pack clips in the desired location, with the screws provided.

Press the battery pack into the clips.

**Note:** Be sure that the battery wire will reach the motor plug at the position that you are installing it.

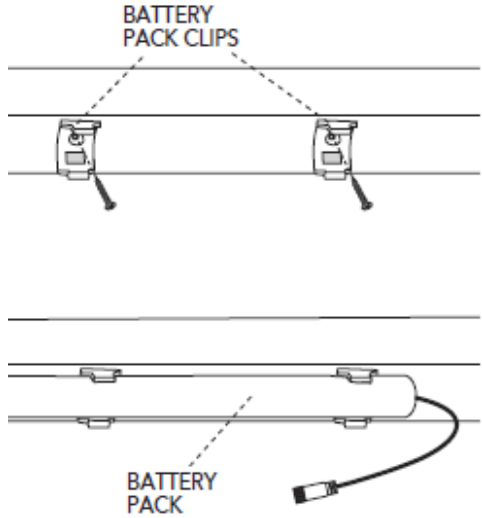

### Attaching the Power Source

Plug the battery wand wire in the motor wire

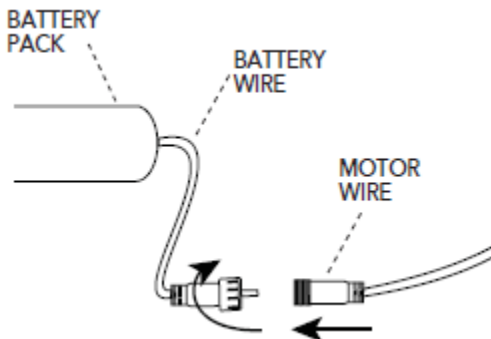

## INSTALLING THE TOP RAIL

Start with the top rail/fabric assembly.

The top rail is the rail with the motor in it.

Before mounting the headrail, make sure that the receiver wire is out of the headrail. For optimal performance position the receiver wire so that it is facing into the room.

Position the motor wire so that it comes out the back side of the shade.

Be sure the motor wire is not pinched by the bracket. Position the rail with the front lip (A) resting on the hooks of all the brackets.

Push the rail firmly up and toward the window until the groove on the rail snaps into place, (B) as shown.

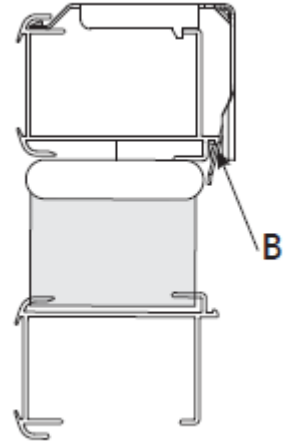
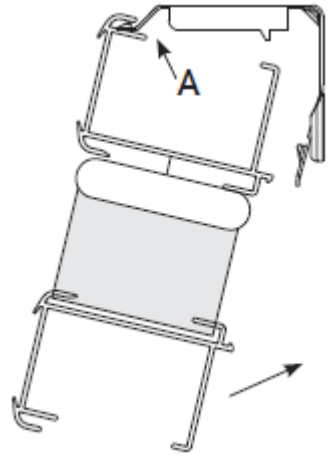

## INSTALLING THE BOTTOM RAIL

Select the desired channel with the "Channel" key. The channel indicator light will illuminate the channel that is on. If all 5 lights are lit, the remote will control all 5 channels at once.

Press the "Down" key to lower the shade.

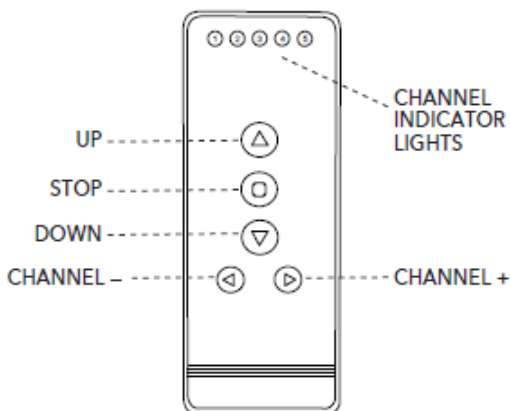

Position the rail with the front lip (A) resting on the hooks of all the brackets.

Push the rail firmly down and toward the window until the groove on the rail snaps into place, (B) as shown.

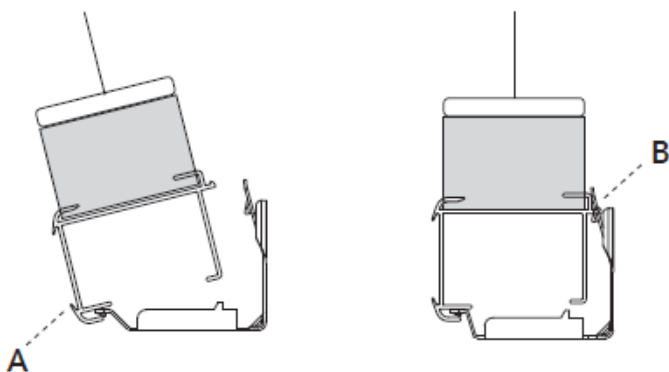

## INSTALLING THE TRACKS

Place the track against the front of the top and bottom rails. Attach the track with the screws provided. Space the screws no more than 12" apart.

Follow the same procedure for the other track. Make sure that the 2 tracks are parallel to each other.

FRONT OF  
TRACK OVERLAPS  
FRONT OF RAILS

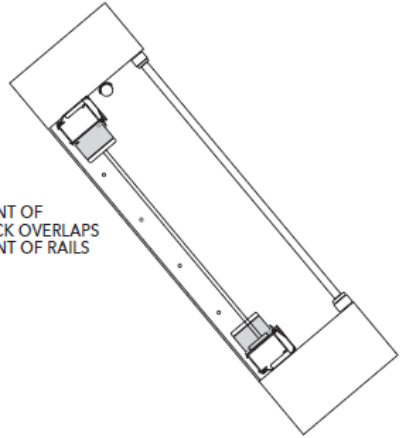
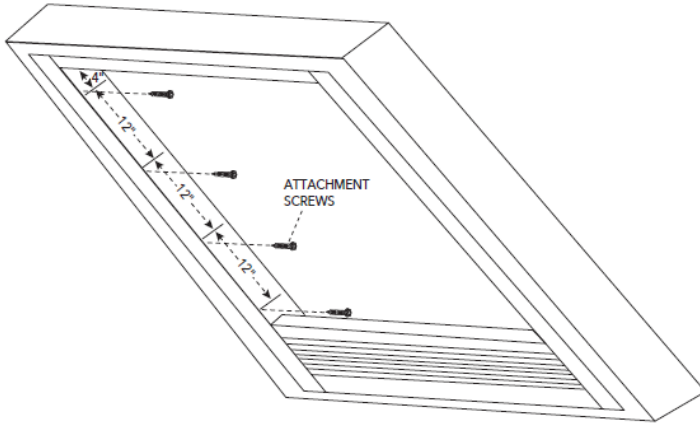



## OPERATING THE SHADE

1. Select the desired channel with the "Channel" key. The channel indicator light will illuminate the channel that is on. If all 5 lights are lit, the remote will control all 5 channels at once.
2. Tapping the "Up" or "Down" keys for less than 2 seconds will move the shade in short steps. Holding the "Up" or "Down" keys down for more than 2 seconds before releasing, will operate the shade in the faster standard speed.
3. Press the "Up" or "Down" keys to raise or lower the shade.
4. Press the "Stop" key to stop the shade anywhere along the travel.

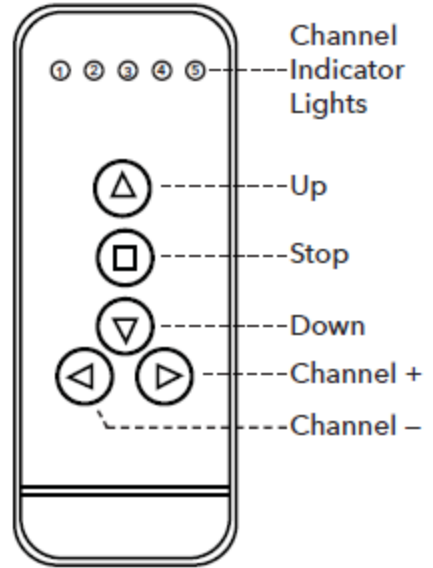

# ADJUST MOTOR LIMITS ON PRIMARY REMOTE (If Desired)

The lower and upper limits have been set at the factory. If you need to make adjustments to the limits, follow the instructions below.

**NOTE:** When clearing the factory set limits, both the upper and lower limits will need to be reset.

Use the **CHANNEL** button to select the channel for the shade that needs to be adjusted. Then follow the directions below. If only adjusting one shade on a channel, unplug the other shades.

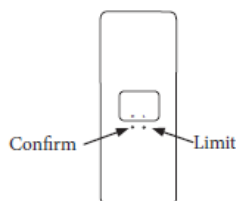
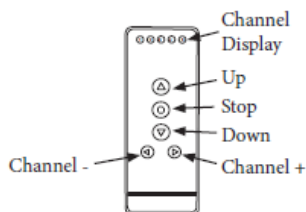

## Setting the Lower Limits

	<b>OPERATION</b>	<b>RESULT</b>
<b>1</b>	Hold <b>LIMIT</b> button down	The motor begins to jog
<b>2</b>	Release the button after jogging starts	The motor is ready for limit setting
<b>3</b>	Press <b>DOWN</b> button	The motor will go down continuously
<b>4</b>	When the motor is close to the desired lower limit, press <b>STOP</b> button on the remote	The motor stops running
<b>5</b>	Press either the <b>UP</b> or <b>DOWN</b> button	The motor runs step by step to adjust lower limit accurately
<b>6</b>	Confirm the setting by pressing the <b>CONFIRM</b> button on the remote	The motor jogs and the lower setting is completed

## Setting the Upper Limits

	<b>OPERATION</b>	<b>RESULT</b>
<b>1</b>	Press <b>UP</b> button on the remote transmitter	The motor will go up continuously
<b>2</b>	When the motor is close to the desired upper limit, press <b>STOP</b> button on the remote	The motor stops running
<b>3</b>	Press either the <b>UP</b> or <b>DOWN</b> button	The motor runs step by step to adjust upper limit accurately
<b>4</b>	Confirm the setting by pressing the <b>CONFIRM</b> button on the remote	The motor jogs and the upper setting is completed

# LEVELING THE SHADE

## Level the Moving Rail

Skylight Shades with Simplicity motorization use a system that allows easy leveling of the moving rail. It is designed to make slight adjustments (Less than 1") to level the moving rails of your shade. It is not designed to make length adjustments.

Use a flat head screwdriver or a dime to turn the adjustment screw to raise or lower that side of the bottom rail. The adjustment screw is on the top of the moving rail.

One quarter turn of the screw will move the moving rail up or down approximately 1/4"

Over-turning the adjustment screw (more than 1" of adjustment) can cause the cord to tangle or wedge inside the rail. The screw should turn easily – Do Not Force.

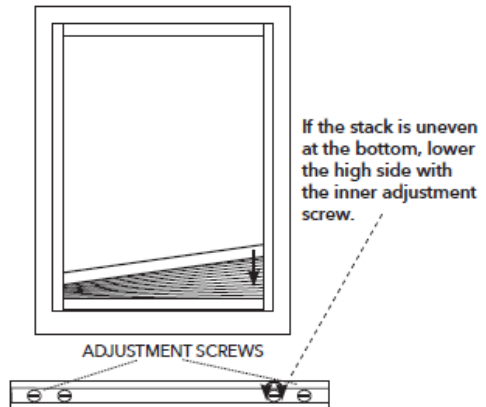
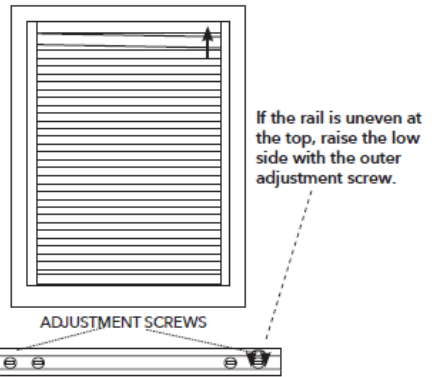
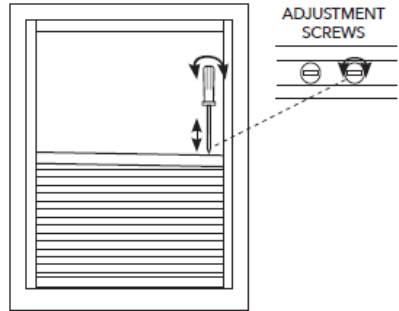



# TROUBLESHOOTING

## THE MOTOR DOES NOT WORK

1. Check that the power source and motor are connected properly.
2. If using a battery wand - confirm that the batteries are fresh and are placed in the wand in the correct orientation.

## THE MOTOR CONTINUES TO RUN IN ONE DIRECTION

The limit setting was unsuccessful and needs to be reset.

## THE MOTOR STOPS WORKING OR WORKS INTERMITTENTLY

If using a battery wand, replace the batteries in the wand with 8 fresh AA alkaline batteries.

## THE INDICATOR LIGHT ON THE REMOTE DOES NOT SHINE OR THE REMOTE-CONTROL RANGE BECOMES SHORTER

Replace the battery in the remote (CR2430 lithium).

# REPLACING THE BATTERY IN THE REMOTE

Remove the battery tray from the remote by inserting a fingernail into the indentation on the back of the remote. To avoid the battery falling out of the remote, remove the tray while the remote is face up.

Insert fingernail here

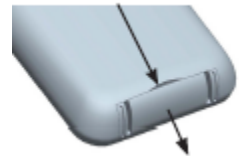

Insert the new battery (CR2430 lithium) into the battery tray so that the writing is facing up when the remote is face up. Slide the tray back into the remote.

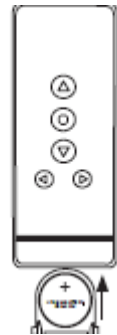



## CLEANING INSTRUCTIONS

Honeycomb shades are made of an anti-static, dust resistant fabric which repels dirt and dust. For most of these fabrics, the following options are available if your shade needs cleaning.

**DUSTING:** Regular light dusting with a feather duster is all the cleaning that is needed in most circumstances.

**VACUUMING:** Use a hand-held vacuum with low suction for more thorough dust removal.

**SPOT CLEANING:** Use the following steps for spot cleaning: (1) Prepare a solution of warm water and mild dishwashing detergent. (2) Dampen a clean cloth in the solution and ring it out. (3) Dab the spot with the dampened cloth until it is gone. **DO NOT RUB THE FABRIC.** (4) Allow the shade to dry in the completely lowered position.

**CAUTION:** Avoid creasing Blackout fabrics during cleaning.

**DEEP CLEANING:** Use the following steps for deep cleaning: (1) Immerse shade in basin or bathtub filled with warm water and mild detergent. (2) Rinse with clean water. (3) Fully raise shade and tilt to eliminate excess water, (4) Reinstall damp shade, lower it, and let it dry completely.

**CAUTION:** Do not immerse Blackout fabrics. Do not immerse the headrail or any fabric-wrapped rail.

**ULTRASONIC CLEANING:** Standard shades, except those made with Blackout Lining can be ultrasonically cleaned by a professional.

- Specify that a mild detergent be used.
- Never immerse the headrail or any fabric-wrapped rail in the solution.
- Dry the shade completely in the lowered position.

**CAUTION:** Do not ultrasonically clean Blackout fabrics. Do not immerse headrail.



# SAFETY NOTES

## WARNING

Inner or exposed cords can pull out to form a loop, which can STRANGLE a young child.

### CHILD SAFETY



- Children can climb furniture to access inner or exposed cords. Move cribs, playpens, and other furniture away from window coverings.
- Always keep cords out of the reach of children.



### CANADIAN RESIDENTS ONLY:



For more safety information  
call 1-866-662-0666 or go to  
[www.healthcanada.gc.ca/blindcords](http://www.healthcanada.gc.ca/blindcords)



## WARRANTY INFORMATION

Lifetime Limited Warranty covering our Custom Made Shades

We extend this lifetime limited warranty to the original purchaser. This warranty applies only to manually operated Custom Products properly installed in the window, door or interior area for which they were intended. Installation of the product must be in accordance with accompanying instructions. The product cannot be modified. It is the purchaser's responsibility to maintain and clean the product in compliance with the instruction provided. The product must be used only in the window for which it was purchased. Damage to the product resulting from misuse, abuse, direct exposure to salty air or discoloration due to sunlight or the passage of time is not covered by this warranty.

This warranty does not apply to conditions caused by normal wear and tear upon the product. This warranty is exclusive and in lieu of all other obligations, liabilities or warranties. In no event shall the Manufacturer be liable for incidental or consequential damages or for any other direct or indirect damage, loss, cost, expense or fee. Some states do not allow the exclusion or limitation of incidental or consequential damages, so this exclusion or limitation may not apply to you.

In the event of a defect under this warranty, we will repair or replace the product, at our option, provided it is returned to our store. Our warranty obligation excludes shipping charges and labor costs for measuring and installation. Repairs will be made with like or similar parts. This warranty gives you specific legal rights, and you may have other rights which vary from state to state.

Notes: Motorization Systems are warranted for five years from the date of purchase. Specialty Blinds and Shades are warranted for one year from the date of purchase.

This warranty does not apply to Commercial Orders.