



DESIGNED TO HEAT.
BUILT TO LAST.

WOOD

FREESTANDING STOVES



The Boston 1200

MEDIUM CAST IRON WOOD STOVE



The Boston 1200, Diamond Black Enamel Finish



The Boston 1200, Chestnut Enamel Finish

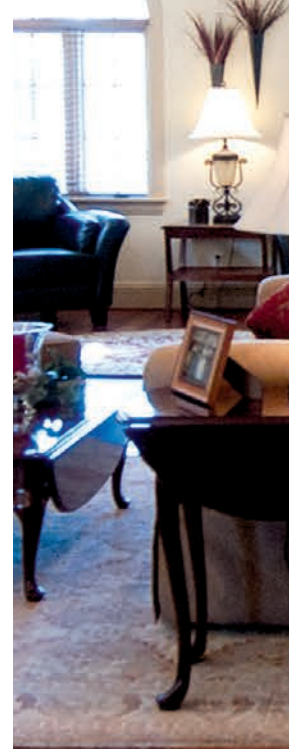

The Boston 1200, Painted Black

Why buy an **Enviro** Freestanding Wood Stove?

Bioenergy...

Enviro has some of the most efficient wood stoves in the business. By using renewable wood fuel you are reducing the amount of fossil fuel emissions and electricity used, lessening the impact on our environment.

In your Enviro wood stove, wood fuel is:

- burned more efficiently, up to 84.7%* (lowering smoke emissions)
- an infinitely renewable resource
- neutral in terms of CO₂ emissions - it is carbon neutral - burning biomass fuel merely releases the CO₂ that the plants absorbed over their life spans
- a cost effective way to heat your home and give you comfort in knowing you are doing your part for the environment.

*See owners manual & specifications for details



The Boston 1700
LARGE CAST IRON WOOD STOVE



The Boston 1700, Painted Black



The Boston 1700, Diamond Black Enamel Finish



The Boston 1700, Chestnut Enamel Finish

Long Burn Times

Progressive Burn Technology is designed to keep hot embers in the firebox after a nights burning. This process is achieved by restricting the air in the back of the firebox, leaving hot embers for you to start up your insert again.

Clean Burning

Secondary air tubes add super-heated air to the fire as the burn progresses to the front for high efficiency and low emissions.



Boston side shelves available in all 3 finishes



Antique Chestnut Porcelain Enamel Finish



Large Concealable Cooking Surface



Chrome Plated Latch and Wooden Handle

The Kodiak 1200

MEDIUM WOOD STOVE



Kodiak 1200, Pedestal, Nickel Door



Kodiak 1200, Step-Top, Nickel Legs, Painted Door



Kodiak 1200, Painted Legs, Nickel Trim Door

1200 & 1700 Performance Features

- large firebox capacity for long overnight burns
- single, easy-to-use air control adjusts the heat output and regulates the fire
- twin pilot injection ports tuned to deliver a fast start-up. These injection ports are 3" above the firebox floor so you can build a good deep ember bed and not affect low burn or start up.
- heavy-duty 304 grade stainless steel secondary air tubes for clean burns
- ultra strong air wash helps to keep the glass clean
- radiant heat is maximized through the large glass area (177 sq. in.)
- up to 18" log length on a 1200 firebox

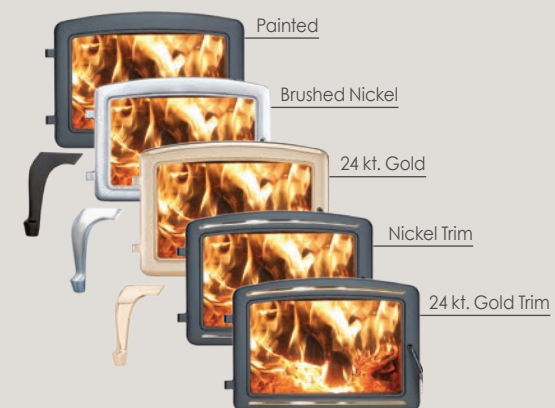

The Kodiak 1700
LARGE WOOD STOVE



Kodiak 1700, Step-Top, Pedestal, Nickel Trim Door



Kodiak 1700, Pedestal, Painted Door



Kodiak 1700, Nickel Legs, Painted Door

Freestanding Wood Stove Features

- Clean Burning - EPA tested as low as 3.3 g/hr.*
- Unlimited Lifetime Warranty -Enviro gives you an unlimited lifetime warranty on the firebox baffle.**
- Up to 20" log length loaded North/South on a 1700 firebox
- Convection Heat -The optional convection fan moves the heat further into your home.

** See owners manual for details.

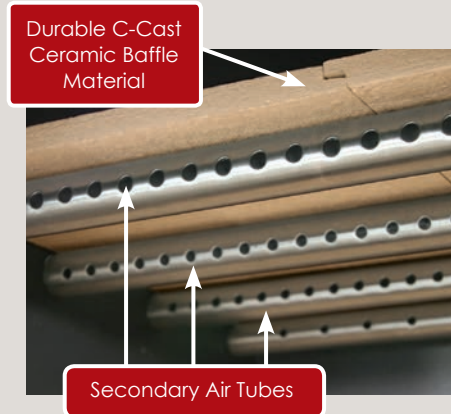

Durable C-Cast Ceramic Baffle Material

Secondary Air Tubes





Features of the 2100 Enviro Wood Stove

Construction -

- up to 5/16" thick steel construction
- 1/2" diameter hinges and door handle
- standard cast iron ash plug and large ash pan
- fully lined brick firebox
- removable secondary air system for maximum efficiency
- Up to 22.5" log length loaded North/South

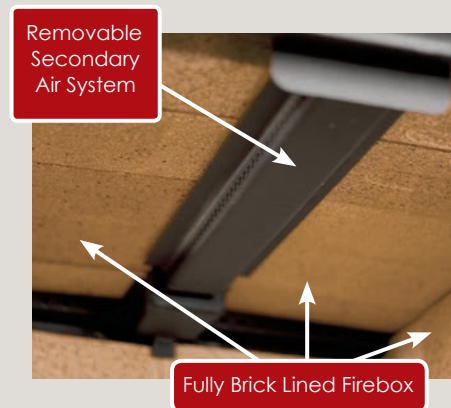

Specifications

Clearances

Performance	The Boston 1200	The Boston 1700	The Kodiak 1200	The Kodiak 1700	The 2100
BTU's*	67,000 BTU's	74,000 BTU's	67,000 BTU's	74,000 BTU's	82,000 BTU's
Heating Area *	2200 sq ft.	3000 sq ft.	2200 sq ft.	3000 sq ft.	3000+ sq ft.
Burn Times *	6 - 10 hours	8 - 12 hours	6 - 10 hours	8 - 12 hours	8 - 12 hours
Maximum Log Size	18"	20"	18"	20"	22.5"
Efficiency**	82.6%	84.7%	82.6%	84.7%	75%
EPA Tested Emissions	3.3 g per hour	4.5 g per hour	3.3 g per hour	4.5 g per hour	2.9 g per hour
Weight (estimated)	410 lbs.	450 lbs.	280 lbs.	320 lbs.	480 lbs.
Firebox Capacity	1.85 cu ft.	2.50 cu ft.	1.85 cu ft.	2.50 cu ft.	3.1 cu ft.
Steel thickness of top	5/16" / 1/4"	5/16" / 1/4"	5/16" / 1/4"	5/16" / 1/4"	5/16" / 1/4"
177 sq in. Glass Size	✓	✓	✓	✓	✓
6" Flue Diameter	✓	✓	✓	✓	✓
Optional Convection Fan	✓	✓	✓	✓	✓
Mobile Home Approved	✓	✓	✓	✓	

* Figures will vary considerably with floor plan, house layout and heat loss of house. Due to on-going product development, product appearances and specifications are subject to change without notice. Efficiency and area heated will vary according to location and fuel. Approved for sale in Canada and the United States.

** Tested to the NSPS standard

1200 & 1700 Air Flow Path

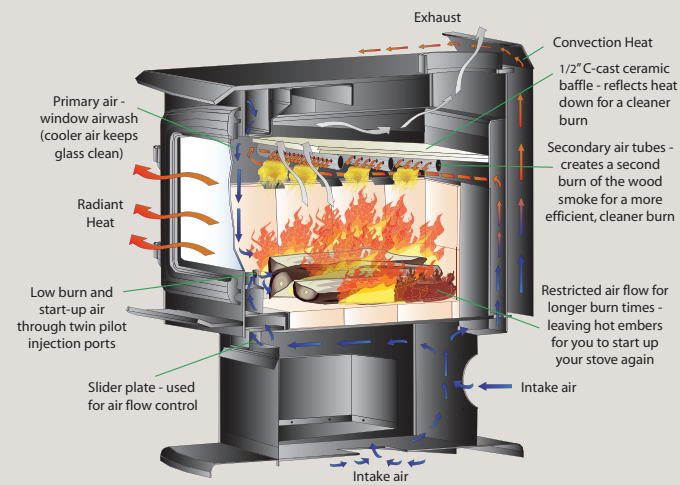

2100 Air Flow Path

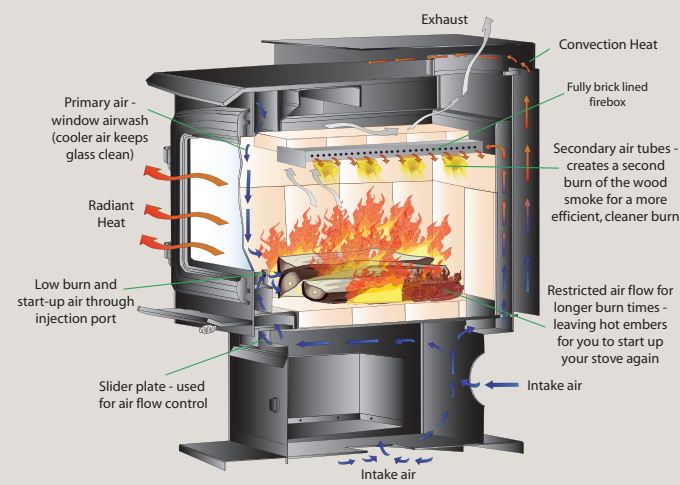

Clearances from Combustibles

	1200 Single Wall Pipe	1200 Double Wall Pipe	1200 (flat top) Double Wall Pipe w/heat shield	1700 Single Wall Pipe	1700 Double Wall Pipe	1700 (flat top) Double Wall Pipe w/heat shield	2100 Single Wall Pipe
A - side wall to side of unit	13"	13"	13"	20"	13"	13"	22"
B - rear wall to back of unit	11"	10"	8"	12"	10"	7"	12"
C - adjacent wall to corner	9"	8"	6 1/2"	10"	8 1/2"	6"	8"
D - side wall to collar	22"	22"	22"	29"	22"	22"	31"
E - rear wall to collar	14"	13"	11"	15"	13"	10"	16 1/2"
F - adjacent wall to collar	17 1/2"	16 1/2"	15"	18 1/2"	17"	14 1/2"	19"
G - door opening to edge of hearth pad	16" (18"CDN)	16" (18"CDN)	16" (18"CDN)	16" (18"CDN)	16" (18"CDN)	16" (18"CDN)	18"
H - side/back of unit to edge of hearth pad	6" (8"CDN)	6" (8"CDN)	6" (8"CDN)	6" (8"CDN)	6" (8"CDN)	6" (8"CDN)	8"

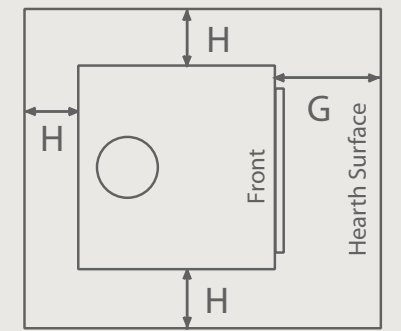
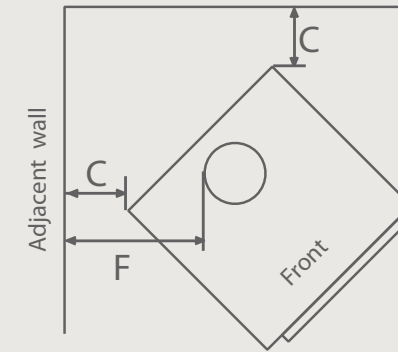
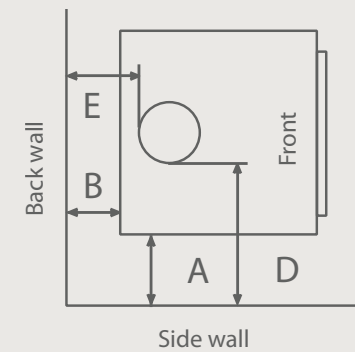

* approx. only - see owner's manual for exact figures

Floor Protection

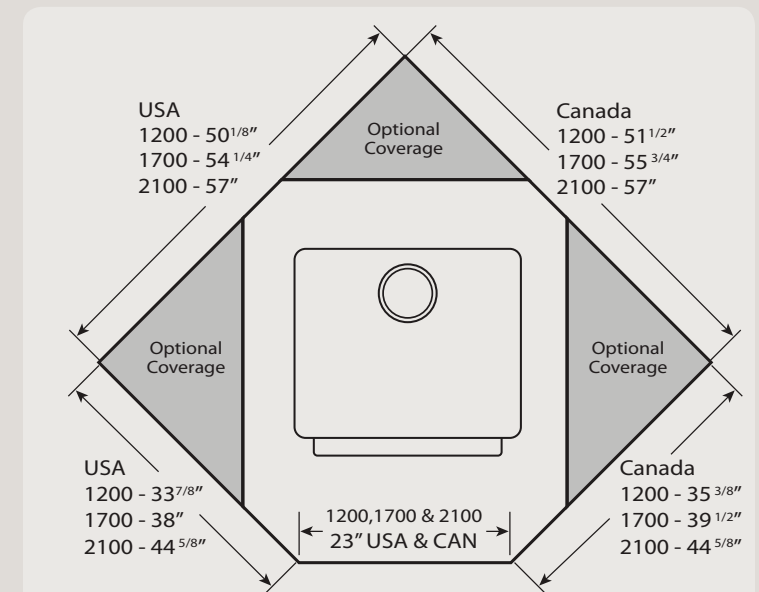
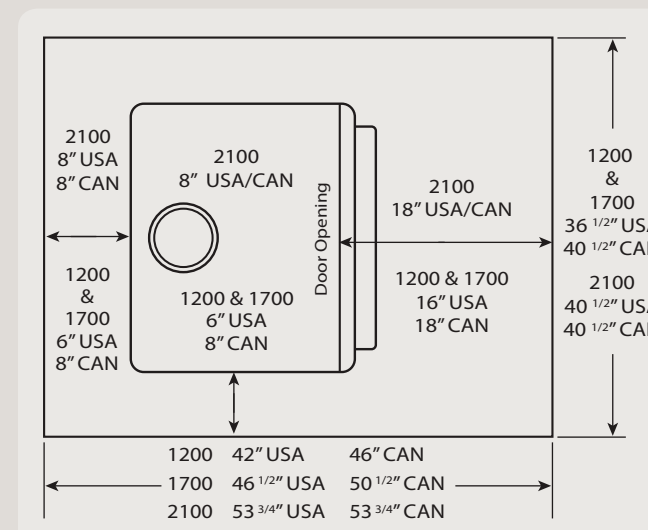

The Boston 1200

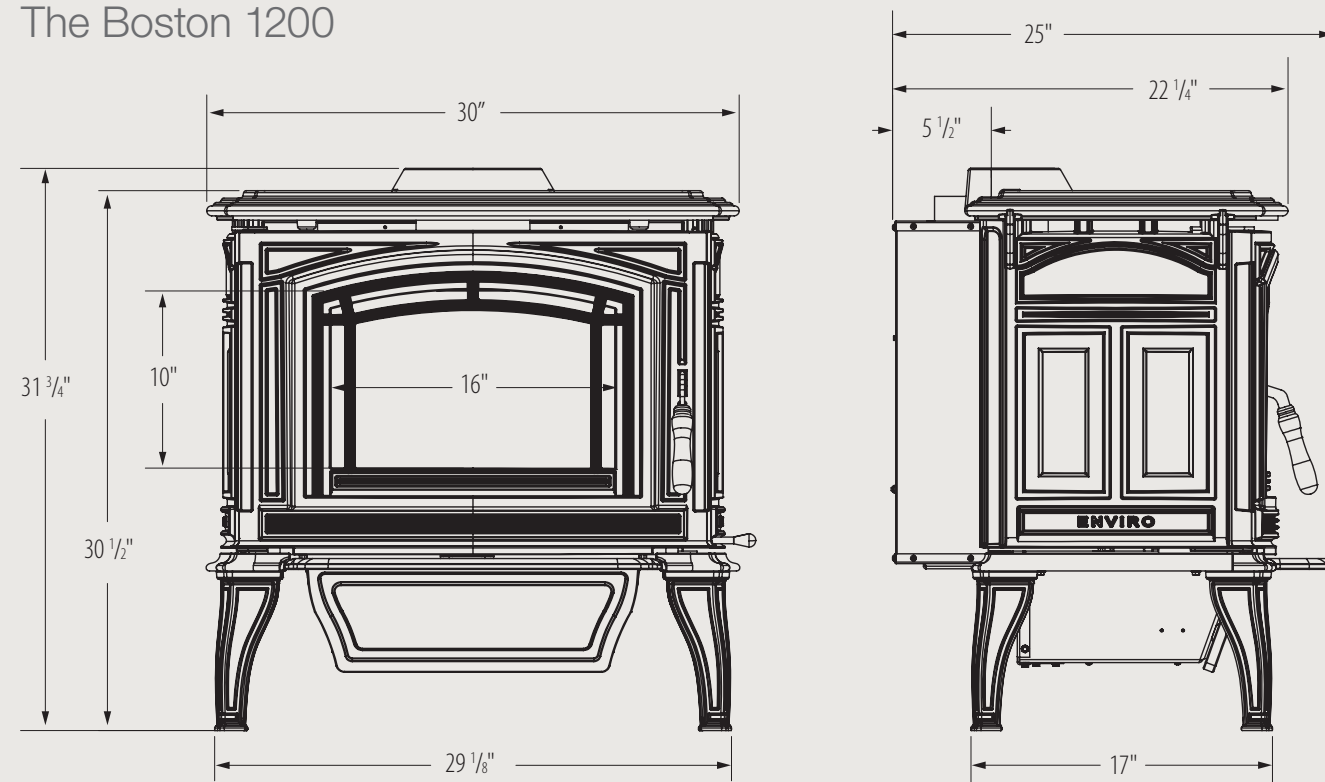

The Kodiak 1200 & 1700

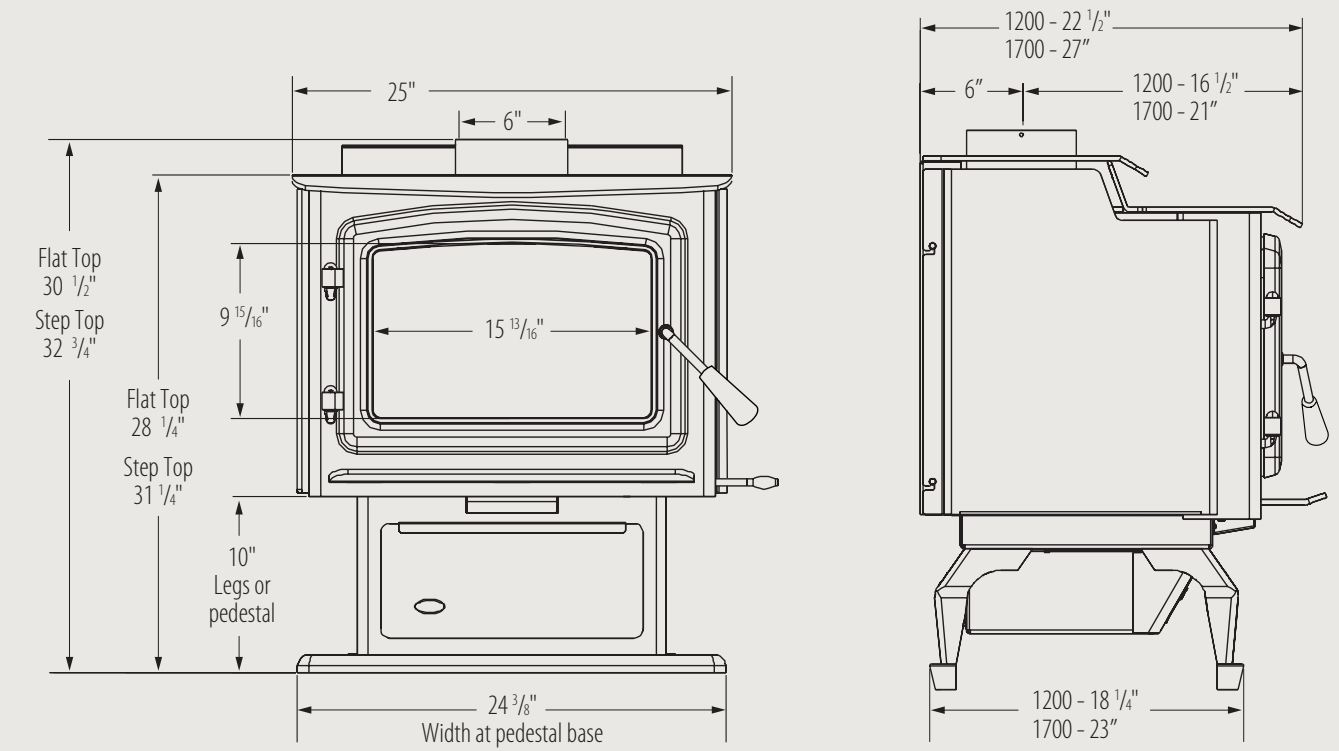

The Boston 1700

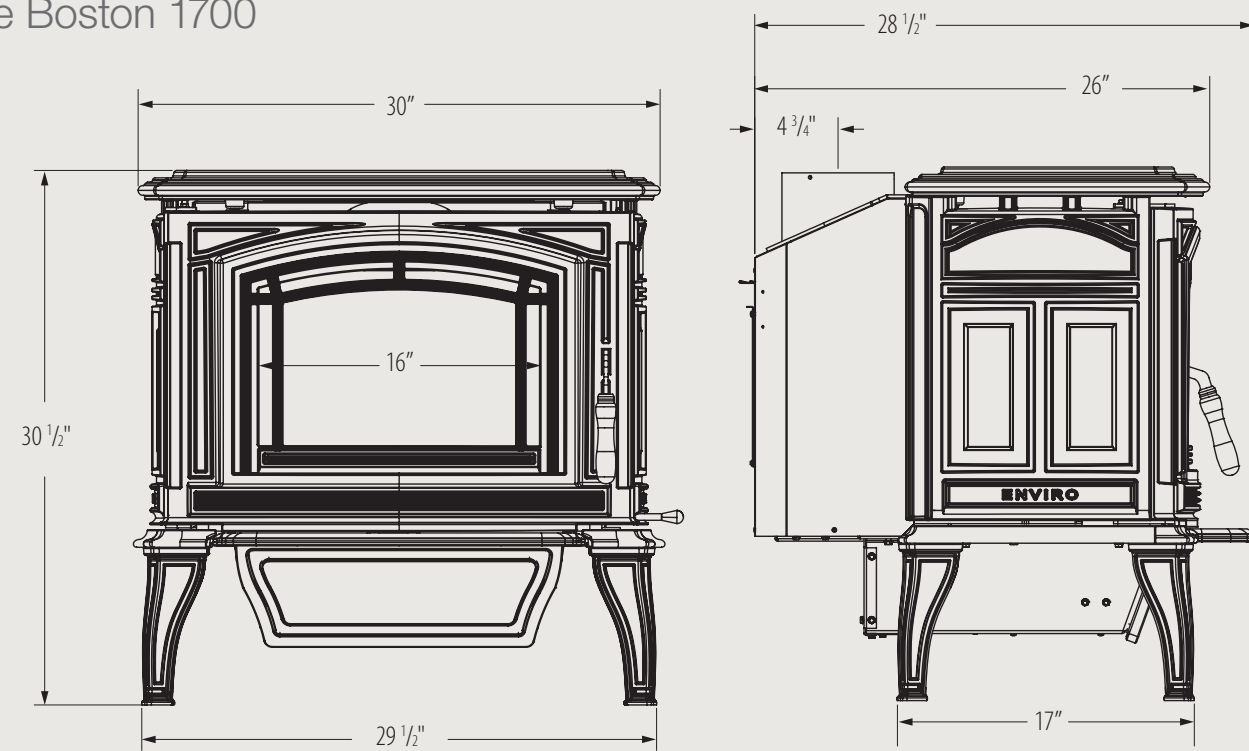

The 2100

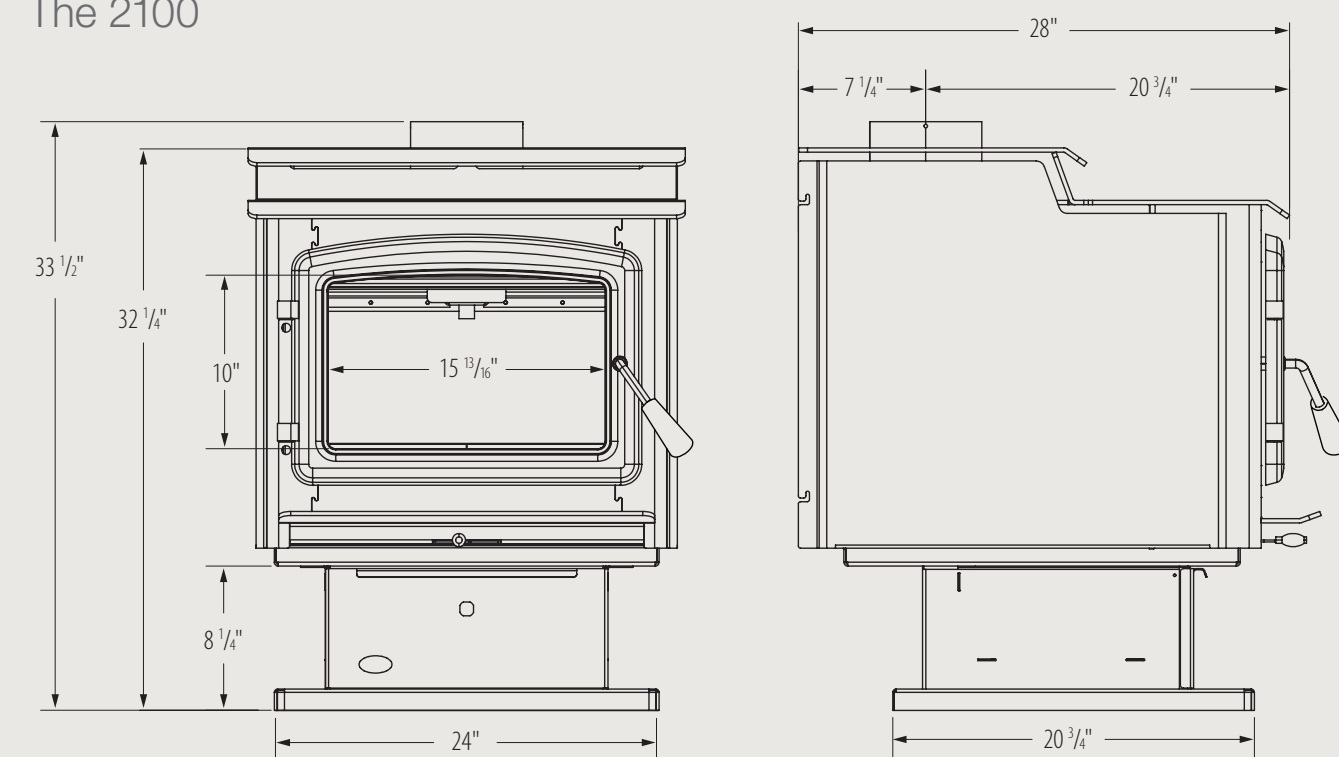

Learn more about
your dream wood stove at

enviro.com

- *Youtube Burn Videos*
- *Detailed Product lineup*
- *Fireplace Photo Galleries*
- *Unit Comparison Charts*
- *Downloadable Manuals*
- *Online Brochures*

