

**INSTALLATION
OPERATION
MAINTENANCE
AND PARTS
MANUAL**

CELLU – KOOL SERIES

<u>MODEL</u>	<u>TYPE</u>	<u>SIZE</u>
<i>CELHP</i>	<i>HEAT PUMP</i>	<i>1 ½ TO 5 TON</i>
<i>CELAC</i>	<i>AIR CONDITIONER</i>	<i>1 ½ TO 5 TON</i>

COMPU – AIRE INC.

8167 BYRON RD. WHITTIER, CA 90606

PH : (562) 945 – 8971 FAX : (562) 696 - 0724

--GETTING OTHER INFORMATION AND PUBLICATIONS

These publications can help you install the air conditioner or heat pump. You can usually find these at your local **library** or purchase them directly from the publisher. Be sure to consult current edition of each standard.

National Electrical Code	-ANSI/NFPA 70
Standard For The Installation Of Air Conditioning and Ventilating Systems	-ANSI/NFPA 90A
Standard For Warm Air Heating and Air Conditioning Systems	-ANSI/NFPA 90B
Load Calculation For Residential Winter and Summer Air Conditioning	-ACCA Manual J
Duct Design For Residential Winter and Summer Air Conditioning and Equipment Selection	-ACCA Manual D

FOR MORE INFORMATION, CONTACT THESE PUBLISHERS

- ACCA:** AIR CONDITIONING CONTRACTORS OF AMERICA
1513 16th Street NW
Washington, DC 20036
Telephone: (202) 483-9370 Fax: (202) 234-4721
- ANSI:** AMERICAN NATIONAL STANDARDS INSTITUTE
11 West Street, 13th Floor
New York, NY 10036
Telephone: (212) 642-4900 Fax: (212) 302-1286
- ASHRAE:** AMERICAN SOCIETY OF HEATING REFRIGERATING AND
AIR CONDITIONING ENGINEERS, INCORPORATED
1791 Tullie Circle, NE
Atlanta, GA 30329-2305
Telephone: (404) 636-8400 Fax: (404) 321-5478
- NFPA:** NATIONAL FIRE PROTECTION ASSOCIATION
Batterymarch Park
P. O. Box 9101
Quincy, MA 02269-9901
Telephone: (800) 344-3555 Fax: (617) 984-7057

CELLU- K O O L AIR CONDITIONER AND HEAT PUMP

SYSTEM REVEALED

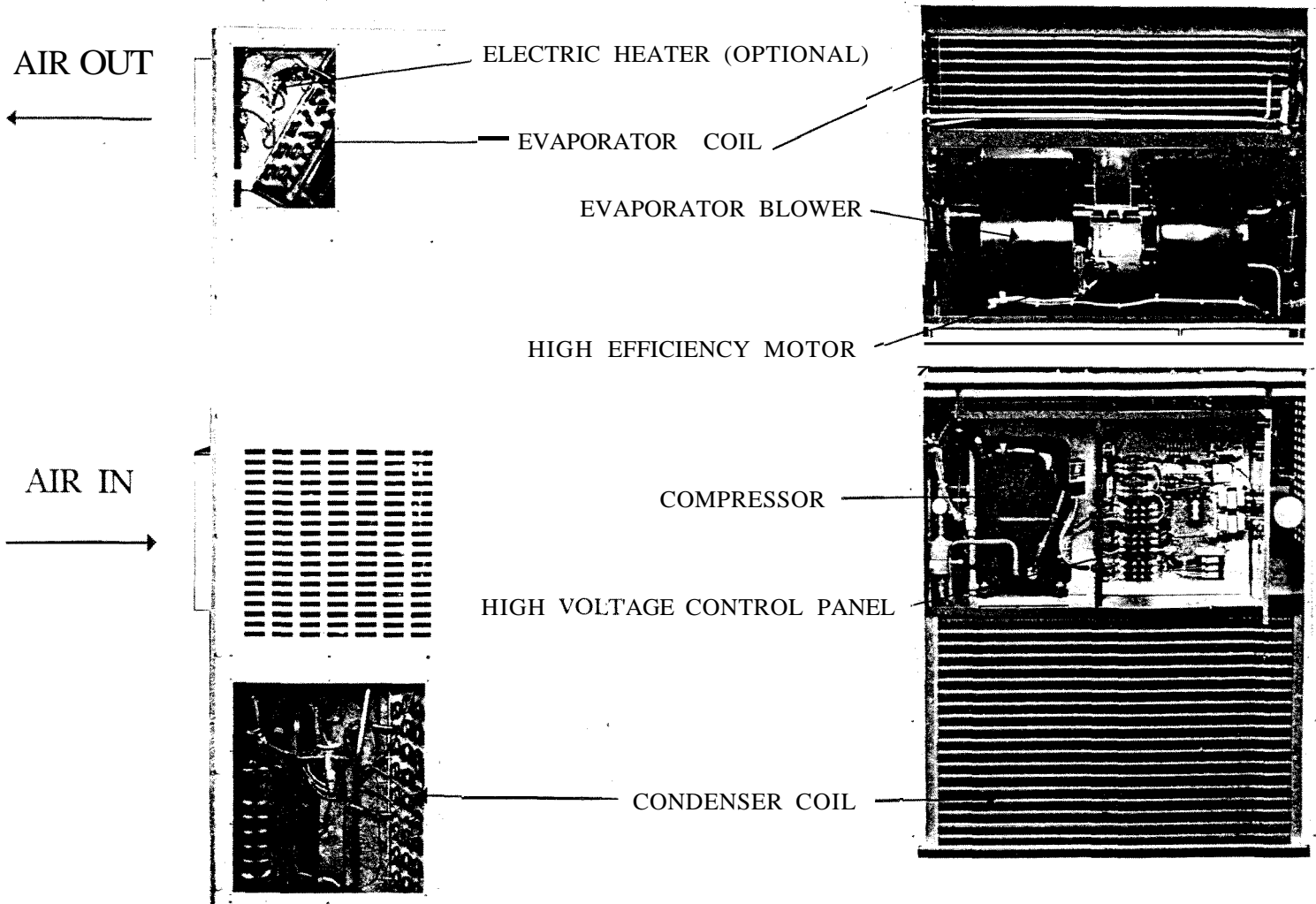

MODEL DESIGNATION

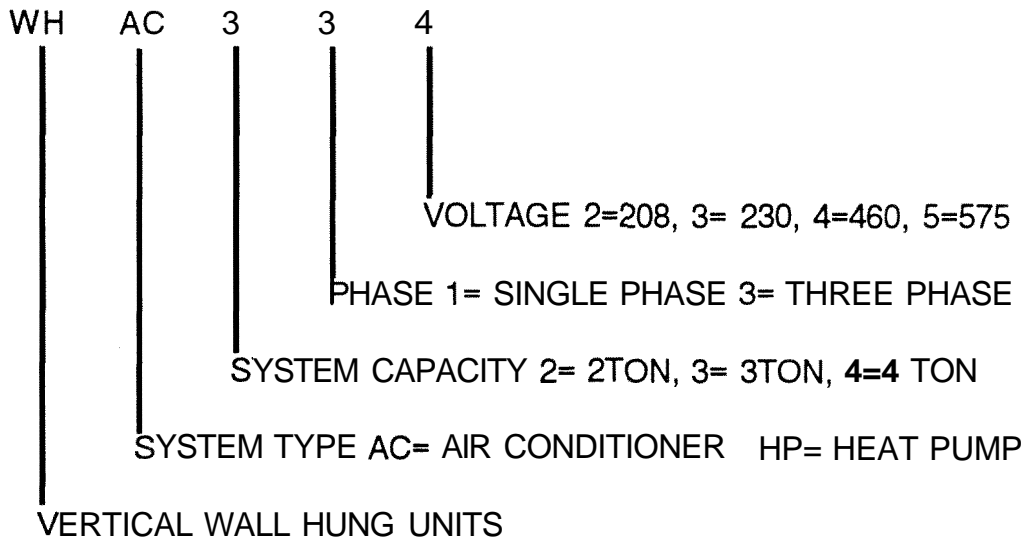

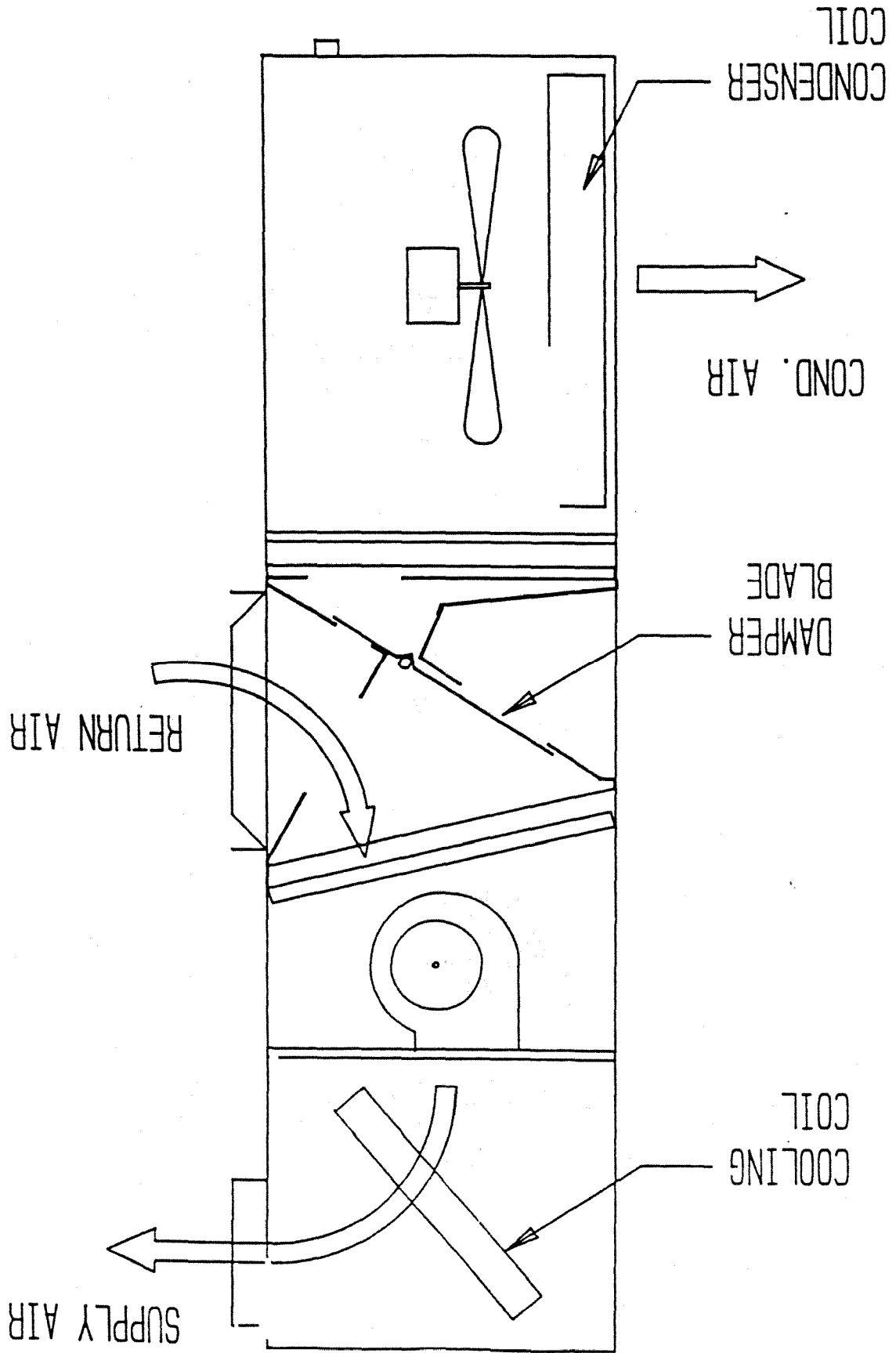
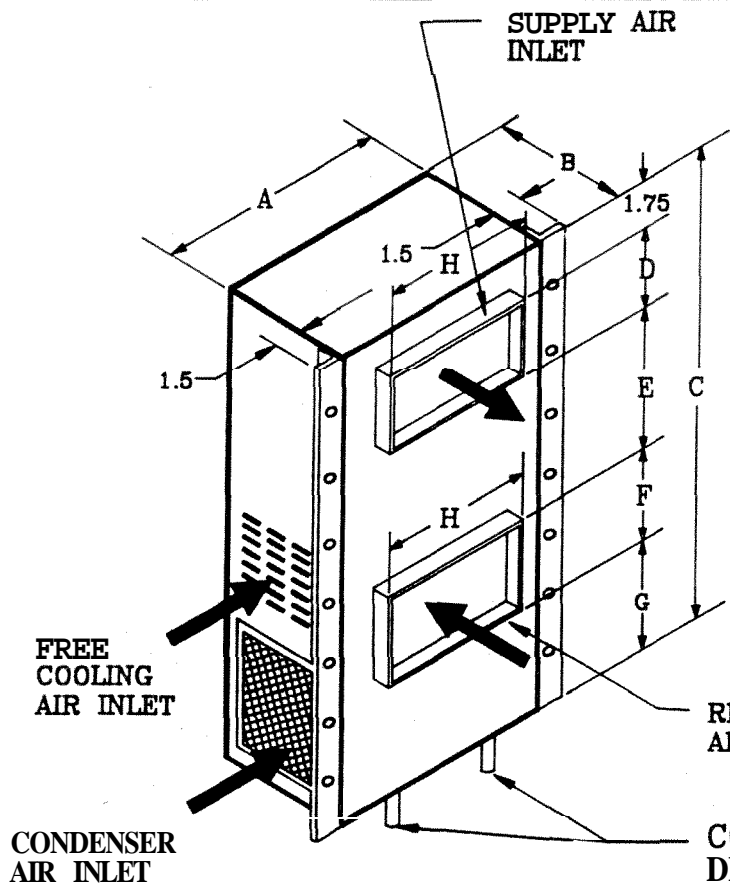
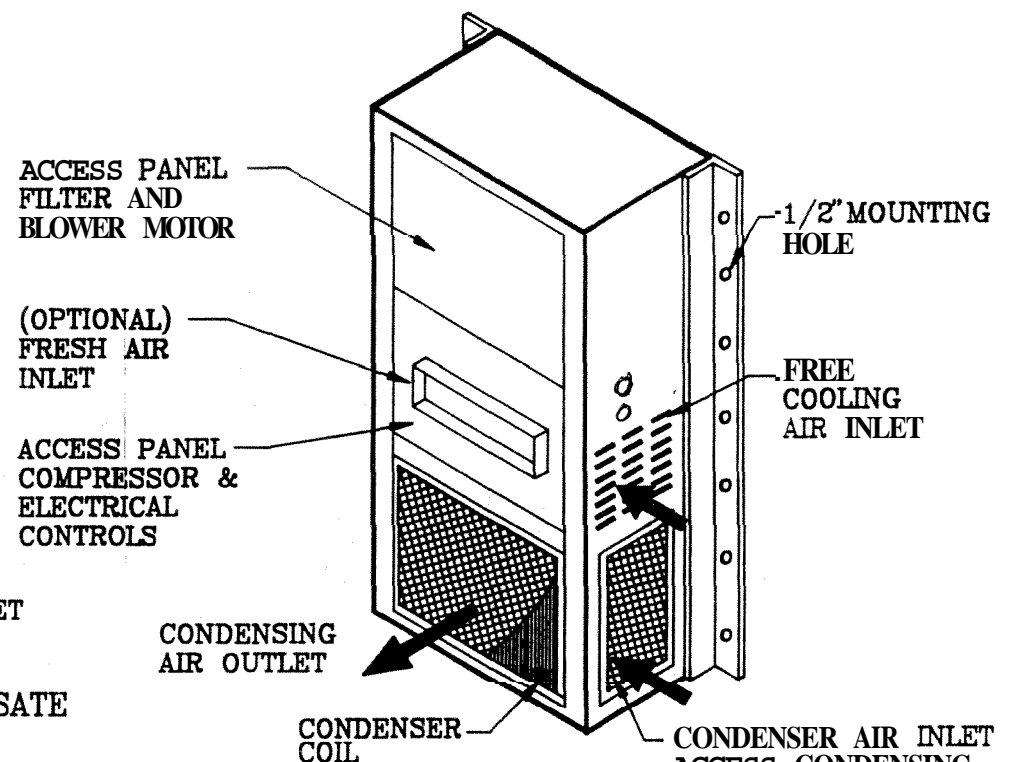

FIGURE 6



REAR VIEW



FRONT VIEW

UNIT SIZE	A	B	C	D	E	F	G	H
WMAC-WMHP 1.5 & 2	33.50	15.25	78.75	8	20.5	12	36.5	20
WMAC-WMHP 2.5 & 3	38.50	17.25	84.25	8	18	14	42.5	28
WMAC-WMHP 3.5,4 & 5	42.50	23.25	87.25	10	30	16	29.5	30

COMPU-AIRE Inc.
 8187 HYRON Rd. WHITTIER CA-90608
 PH:(310)945-8971 FAX:(310)996-0724

WALL MOUNTED AIRCONDITIONER
WALL MOUNTED HEAT PUMP

SCALE: NONE DATED: 10-20-92
 DRAWN BY: N KUMAR REVISED: 4-9-93
 APPROVED BY: DWG NO: 606-901-001

~7.27

FIGURE 7

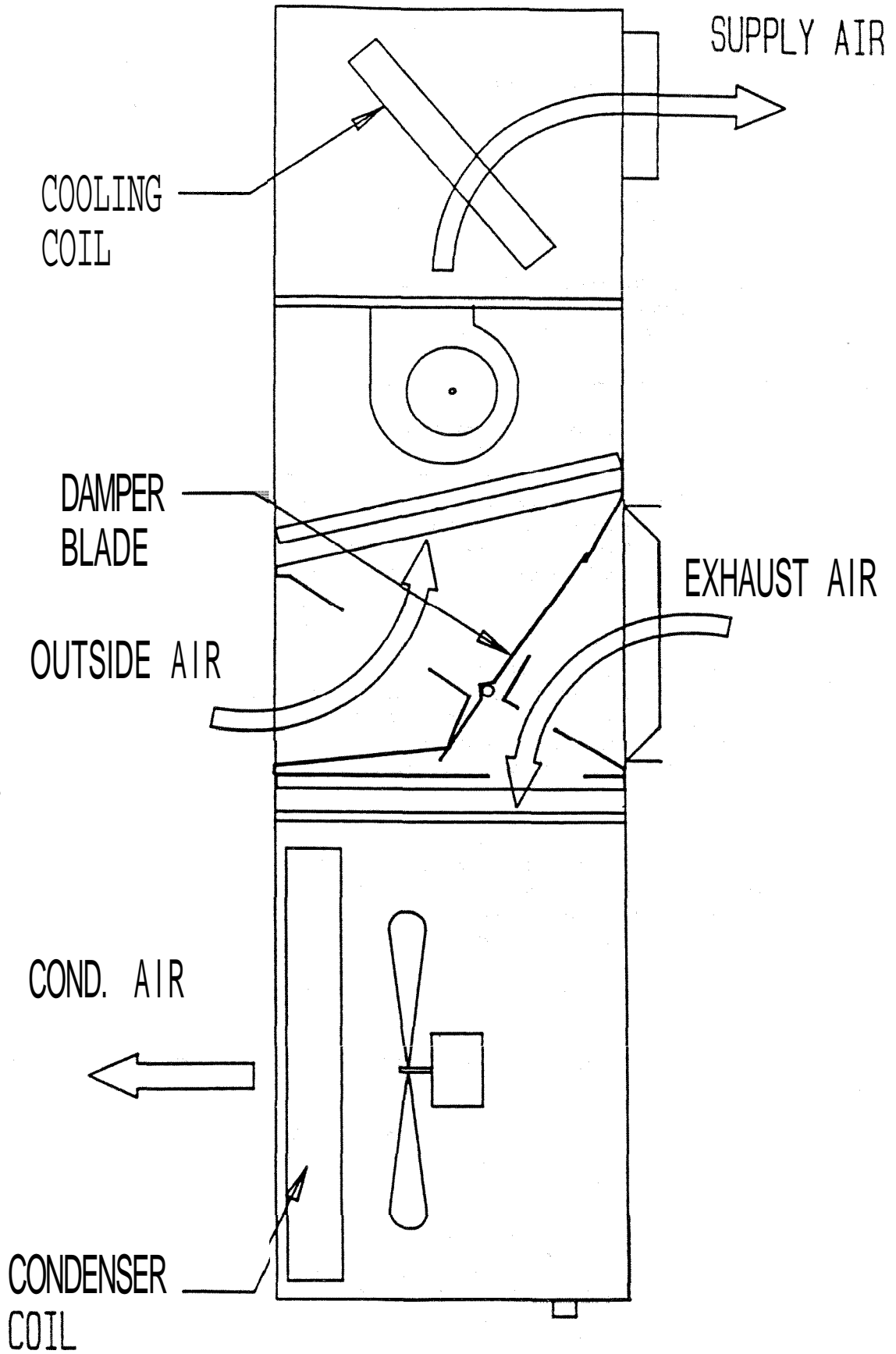

GENERAL

The equipment covered in this manual is to be installed by **trained**, experienced service and **installation** technicians.

The refrigerant system is completely assembled and charged. All internal wiring is complete.

The unit is designed for use with or without duct work. Flanges are provided for attaching the supply and return ducts.

These instructions explain the recommended method to install the air cooled self-contained **unit** and the electrical wiring connections to the unit.

These instructions and any instructions packaged with any separate equipment required to make up the entire air conditioning system should be carefully read before beginning the installation. Note particularly "Starting Procedure" and any tags and/or labels attached to the **equipment**.

While these instructions are intended as a general recommended guide, they do not supersede any national and/or local codes in any way. Authorities having jurisdiction should be consulted before the installation is **made**. See Page 1 for information on codes and standards.

Size of unit for a proposed installation should be based on heat loss calculation made according to **methods** of Air Conditioning Contractors of **America (ACCA)**. The air duct should be installed in accordance **with** the Standards of the National Fire **Protection Association** for the Installation of Air **Conditioning** and Ventilating systems of Other Than Residence Type. NFPA No. **90A**, and Residence Type Warm Air **Heating** and Air Conditioning Systems. **NFPA No. 90B**. Where local regulations are at a variance with **instructions**, Installer should adhere to local codes.

DUCT WORK

Any heat pump is **more** critical of proper operating charge and an adequate duct system than a straight air conditioning unit. All duct work, supply and return, **must** be properly sized for **the** design air flow requirement of the equipment. Air Conditioning Contractors of America (**ACCA**) is an excellent guide to proper sizing. All duct work or portions thereof not in the conditioned space should be properly insulated in order to both **conserve** energy and prevent condensation or moisture damage,

Design the duct work according to **methods** given by the Air Conditioning Contractors of America (**ACCA**). When duct runs through unheated spaces, it should be insulated with a **minimum** of one inch of insulation. Use insulation with a vapor barrier on the outside of the insulation. Flexible joints should be used to connect the duct **work** to the **equipment** in order to keep the noise transmission to a **minimum**.

A 1 1/2-inch clearance to combustible material for the first three feet of duct attached to the outlet air frame is required.

Ducts through the walls must be insulated and all joints taped or sealed to prevent air or moisture entering the wall cavity,

CAUTION: Some installations may not require any return air duct. A metallic return air grille is required with installations not requiring a return air duct. The spacing between louvers on the grille shall not be larger than 5/8 inches.

Any grille that meets the 5/8 inch louver criteria, may be used. It is **recommended** that **Compu-Aire** Return Air Grille Kit be installed when no return duct is used. Contact distributor or factory for ordering **information**. If using a return air filter grille, filters must be of sufficient size to allow a maximum velocity of 400 fpm.

NOTE: If no return air duct is used, applicable installation codes may **limit** this cabinet to installation only in a single story structure.

FILTERS

A 1-inch throwaway filter is supplied with each unit. The filter slides into position **making** it easy to service. This filter can be serviced from the outside by **removing** the service **door**. A 1-inch washable filter and 2-inch pleated **filter** are **also** available as optional accessories. The internal filter brackets are adjustable to accommodate the 2-inch filter by **loosening** 2 screws in each bracket assembly and sliding the brackets apart to the required width and retightening the 4 screws. OPTIONAL

FRESH AIR INTAKE

All units are built with a fresh air inlet slots punched in the service panel.

The fresh air damper assembly is standard **equipment** with the unit because of the variety of state or local **codes** requiring fresh air capability. It is shipped already attached to each unit.

All capacity, efficiency and cost of operation information as required for **Department** of Energy "**Energyguide**" Pact Sheets is based **upon** the fresh air blank-off plate in place and is recommended for **maximum** energy efficiency.

The blank-off plate is available upon request from the factory and is installed in place of the fresh air **damper** shipped with each unit.

CONDENSATE DRAIN

A plastic drain hose extends from the drain pan at the top of the unit down to the **unit** base, There are openings in the unit base for the drain hose to pass through. In the event the drain hose is connected to a drain **system** of **some** type, it **must be** an open or vented type **system** to assure proper drainage.

-- INSTALLATION INSTRUCTIONS

WALL MOUNTING INFORMATION

1. Two holes, for the supply and return air openings, must **be** cut through the wall as shown in Figure 2,
2. On wood-frame walls, the wall construction must be strong and rigid enough to carry the **weight** of the unit without transmitting any unit vibration. **WARNING:** Fire hazard can result if 119-inch clearance to **combustible** materials for supply air duct is not **maintained**. See Figure 2,
3. Concrete block walls **must** be thoroughly inspected to insure that they are capable of **carrying** the weight of the installing unit.

MOUNTING THE UNIT

1. These units are secured by wall **mounting** brackets which secure the unit to the outside wall surface at both sides. A bottom **mounting** bracket is **provided** for ease of installation, but is not required.
2. The unit itself is suitable for "0" inch clearance, but the supply air duct flange and the first three feet of supply air duct require a **minimum** of 1/4-inch clearance to combustible material, If a combustible wall. use a **minimum** of 28-1/2" x 8-1/2" dimensions **for** sizing. However, **it** is generally recommended that a 1" clearance is used for ease of installation and maintaining the required clearance to combustible material. The supply air opening would then be 30" x 10". See Figures 2 and 2A for details.

WARNING: Failure to provide the 1/4-inch clearance between the supply duct and a combustible surface for the first three feet of duct can result in fire.

3. Locate and mark lag bolt locations and **bottom** mounting bracket location, if desired. See Figure 2,
4. **Mount bottom mounting** bracket. if used.
5. Book top rain flashing under back bend of top. Top rain flashing is shipped attached to the back of the unit on the right side.
6. Position unit in opening and secure with 5/16 lag bolts: use 3/4 inch diameter flat washers on the lag bolts.
7. Secure rain flashing to wall and caulk across entire length of top. See Figure 7.
8. For additional **mounting** rigidity, the return air and supply air frames or collars can be drilled and screwed or welded to the structural wall itself (depending upon wall construction). Be sure to observe required clearance if combustible wall.
9. **On side by side** installations, maintain a **minimum** of 20 inches clearance on right side to allow access to control panel and heat strips and allow proper airflow to the **outdoor** coil. Additional clearance may be required to **meet** local or national codes.

TOP OUTLET ONLY

1. **Remove airframe** angles **from** the back of the unit.
2. Coat angles with (2) 1/8" beads of silicone as shown. Silicone is shipped in the control panel. See Figure 2B.
3. Secure angles to the top of the unit with (14) screws provided. Use of prepunched holes provided. **Do** not relocate. See Figure 2B.
4. After installation of ductwork, seal around airframe and **ductwork** to **provide** a rain **tight** seal.
5. It is strongly recommended, but not required, that this unit be installed under a soffit area **large** enough to shield the top of the unit. See Figure 2C.

FIGURE 2
MOUNTING INSTRUCTIONS

	A	B	C	D	E
REQUIRED DIMENSIONS TO MAINTAIN 1/4" MIN. CLEARANCE FROM COMBUSTIBLE MATERIALS	28 1/2	8 1/2	5 1/4	3 13/16	17 5/8
REQUIRED DIMENSIONS TO MAINTAIN RECOMMENDED 1" CLEARANCE FROM COMBUSTIBLE MATERIALS	30	10	4 1/2	3 1/16	16 7/8

NOTE: IT IS RECOMMENDED THAT A BEAD OF SILICONE CAULKING BE PLACED BEHIND TEE SIDE MOUNTING FLANGES AND UNDER THE TOP FLASHING AT TIME OF INSTALLATION.

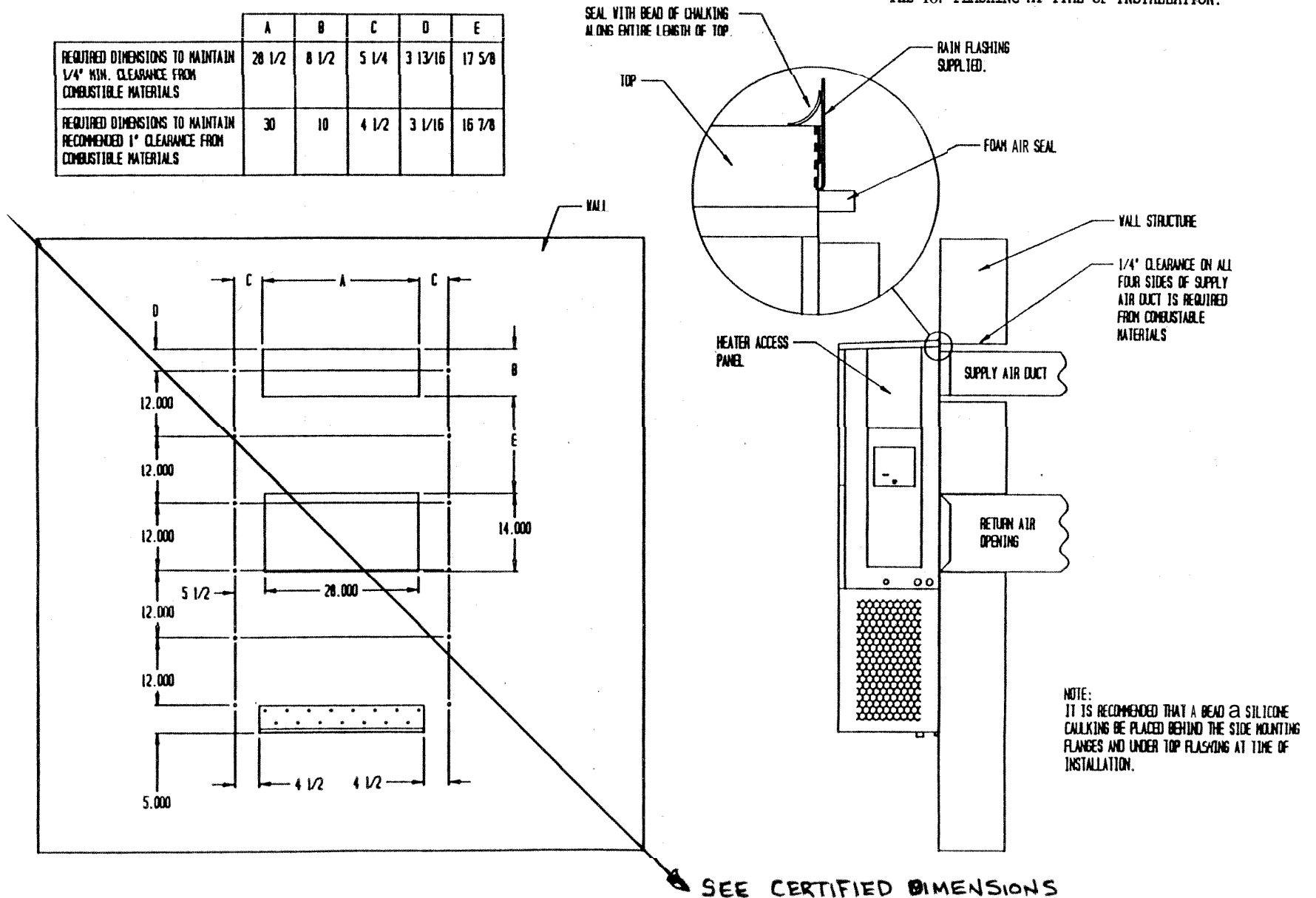
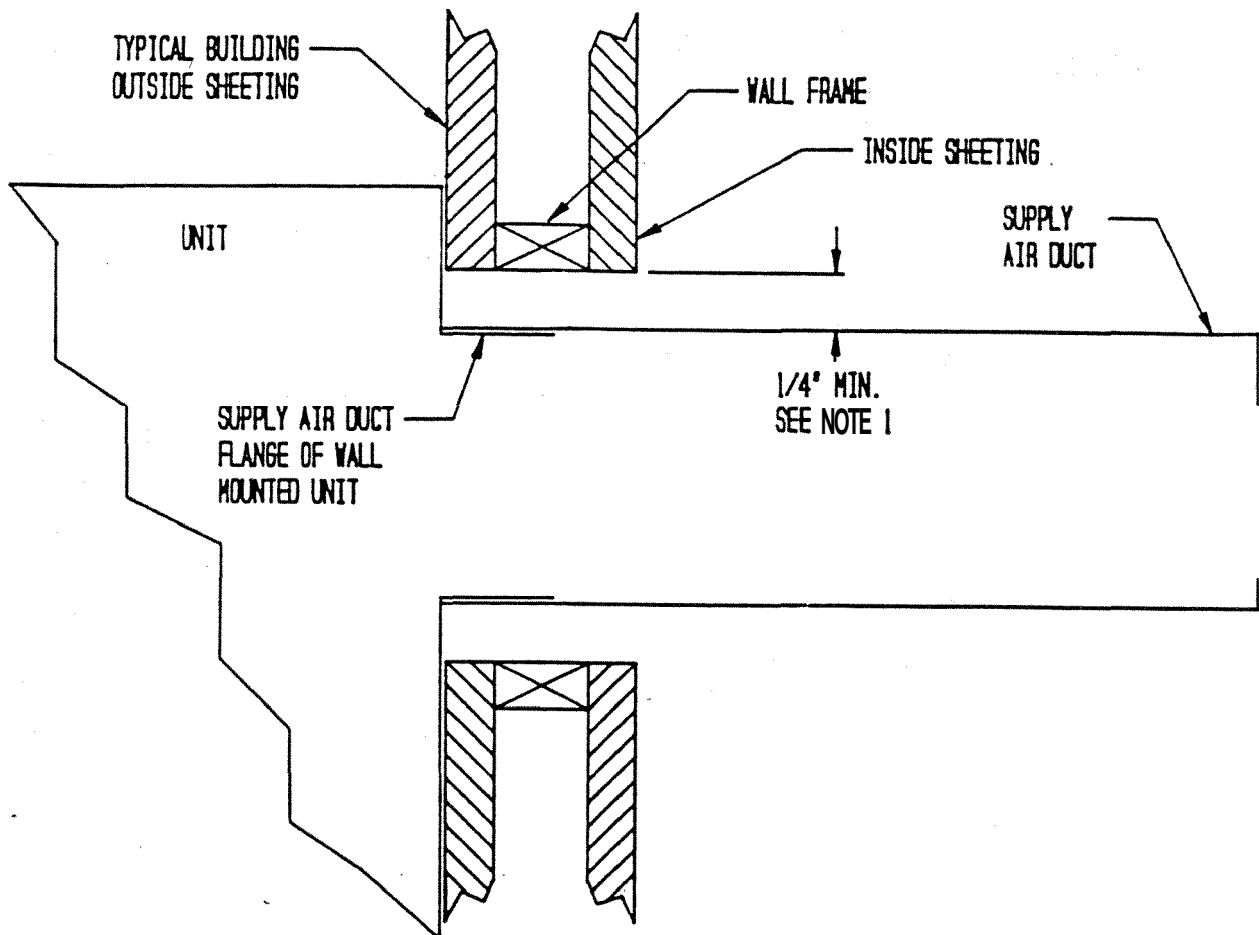

FIGURE 2A
ELECTRIC BEAT CLEARANCE



Side section view of supply air duct for wall **mounted** unit showing 1/4" clearance to combustible surfaces.

NOTE 1:

WARNING

A **minimum** of 1/4" clearance **must** be **maintained** between the supply air duct and combustible **materials**. This is required for the first 3 feet of ducting.

It is **important** to insure that the 1/4" **minimum** spacing is maintained at all **points**.

Failure to do this could result in overheating the **combustible material** and **may** result in a fire.

FIGURE 2B

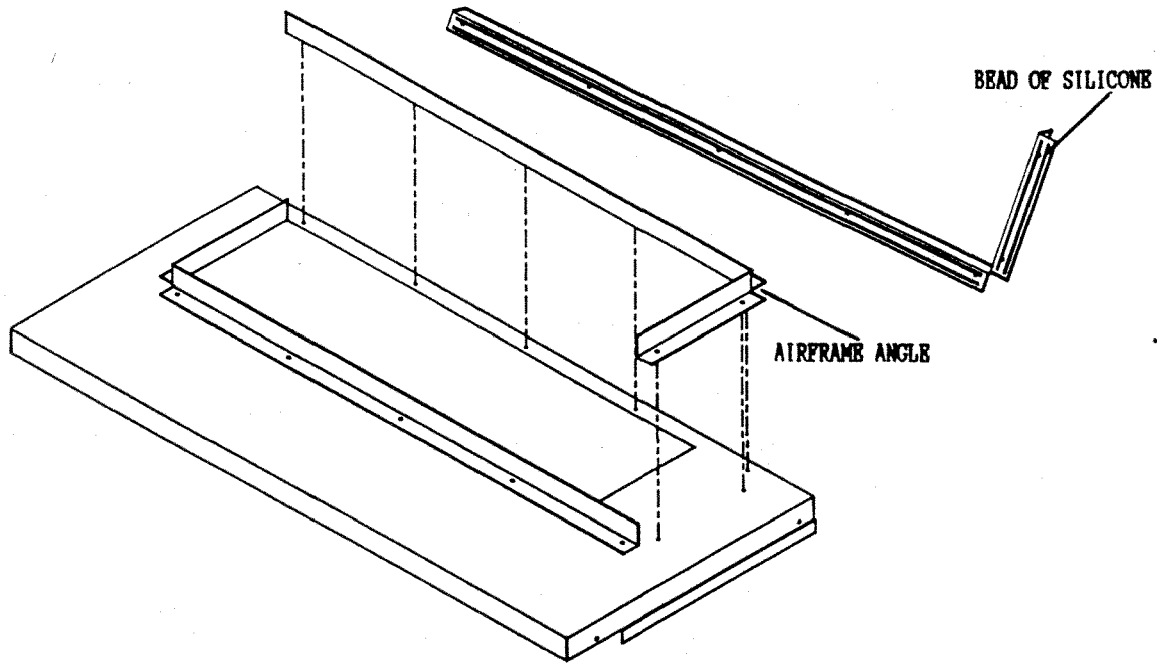
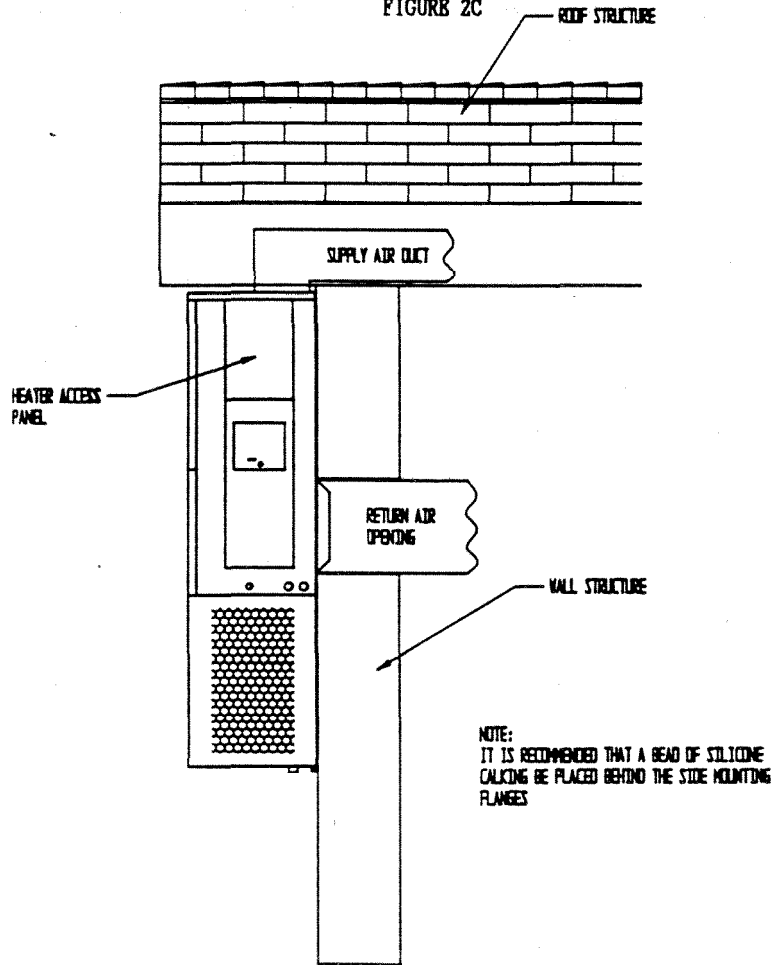

FIGURE 2C



WIRING—MAIN POWER

Refer to the unit rating plate for wire sizing information and maximum fuse or "HACR Type" circuit breaker size. Each outdoor unit is marked with a "Minimum Circuit Ampacity". This means that the field wiring used must be sized to carry that amount of current. Depending on the installed kW of electric heat, there may be two field power circuits required. If this is the case, the unit serial plate will so indicate. All models are suitable only for connection with copper wire. Each unit and/or wiring diagram will be marked "Use Copper Conductors Only". These instructions MUST BE adhered to. Refer to the National Electrical Code (NEC) for complete current carrying capacity data on the various insulation grades of wiring material. All wiring must conform to NEC and all local codes.

The electrical data lists fuse and wire sizes (75°C copper) for all models, including the most commonly used heater sizes. Also shown are the number of field power circuits required for the various models with heaters.

The unit rating plate lists a "Maximum Time Delay Relay Fuse" or "HACR Type" circuit breaker that is to be used with the equipment. The correct size must be used for proper circuit protection and also to assure that there will be no nuisance tripping due to the momentary high starting current of the compressor motor.

SERVICE HINTS

1. Caution homeowner to maintain clean air filters at all times. Also, not to needlessly close off supply and return air registers. This reduces air flow through the system, which shortens equipment service life as well as increasing operating costs.
2. Switching to heating cycle at 75°F or higher outside temperature may cause a nuisance trip of the remote reset high pressure switch. Turn thermostat off, then on the reset the high pressure switch.
3. The heat pump wall thermostats perform multiple functions. Be sure that all function switches are correctly set for the desired operating mode before trying to diagnose any reported service problems.
4. Check all power fuses or circuit breakers to be sure they are the correct rating.
5. Periodic cleaning of the outdoor coil to permit full and unrestricted airflow circulation is essential.

SEQUENCE OF OPERATION

COOLING--Circuit R-Y **energizes** at thermostat pulling in compressor contactor, starting the compressor and outdoor motor. The G (indoor motor) circuit is **automatically** completed on any call for cooling operation or can be energized by **manual fan switch** on subbase for constant **air** circulation.

HEATING--A 24V solenoid coil on **reversing** valve controls heating cycle operation. Two **thermostat** options. one allowing "Auto" changeover from cycle to cycle and the other constantly **energizing solenoid coil** during heating season and thus eliminating pressure equalization **noise** except during defrost, are to be used. On "Auto" option. a circuit is completed **from R-W1** and R-Y on each heating "on" cycle, **energizing reversing** valve solenoid and pulling in compressor contactor **starting compressor** and outdoor motor. R-G also **energize** starting indoor blower motor. Heat Pump heating cycle now in operation. The second option has no "Auto" changeover position. but instead energizes the reversing valve solenoid constantly whenever the system **switch** on subbase is placed in "Heat" position. the "B" terminal being constantly **energized** from R. A thermostat demand for heat **completes** R-Y circuit, pulling in **compressor contactor** starting **compressor** and outdoor motor. R-G also **energize** starting indoor blower motor.

PRESSURE SERVICE PORTS

High and low pressure service ports are installed on all units so that the system **operating** pressures can be observed. Pressure curves can be found later in the manual covering all **models** on both cooling and heating cycles. It is imperative to **match** the correct pressure curve to the unit by **model** number.

DEFROST CYCLE

The defrost cycle is controlled by **temperature** and **time** on the solid state heat **pump** control,

When the outdoor temperature is in the lower **40°F** temperature range or colder, the outdoor coil temperature is **32°F** or below. This coil temperature is sensed by the coil sensor **mounted** near the **bottom** of the outdoor coil. Once coil temperature reaches **30°F** or below. the coil sends a signal to the control logic of the heat **pump** control and the defrost **timer** will start.

After **60 (90 or 30) minutes** at **30°F** or below, the heat pump control will place the system in the defrost mode.

During the **defrost** mode, the refrigerant cycle switches back to the cooling cycle, the outdoor motor **stops**, electric heaters are energized, and hot gas passing through the outdoor coil **melts** any accumulator frost. **When** the temperature rises to approximately **57°F**, the coil sensor will send a signal to the heat pump control which will return the **system** to heating operations **automatically**.

If **some** abnormal or **temporary** condition such as a high wind causes the heat **pump** to have a prolonged defrost cycle, the heat pump control will restore the **system** to heating operation automatically after 10 minutes.

TROUBLESHOOTING

SOLID STATE HEAT PUMP CONTROL TROUBLESHOOTING PROCEDURE

1. Turn on AC power supply to indoor and outdoor units.
2. Turn thermostat blower switch to fan on--the indoor blower should start. (If it doesn't, troubleshoot indoor unit and correct problem).
3. Turn thermostat blower switch to auto position. Indoor blower should stop.
4. Set system switch to heat or cool. Adjust thermostat to call for heat or cool--The indoor blower, compressor, and outdoor fan should start.

NOTE: If there was no power to 24 volt transformer, the compressor and outdoor fan motor will not start for 5 minutes. This is because of the compressor short cycle protection.

FAN BLADE SETTING DIMENSIONS

Shown in the drawing below are the correct fan blade setting dimensions for proper air delivery across the outdoor coil.

Any service work requiring removal or adjustment in the fan and/or motor area will require that the dimensions below be checked and blade adjusted in or out on the motor shaft accordingly.

FIGURE 8

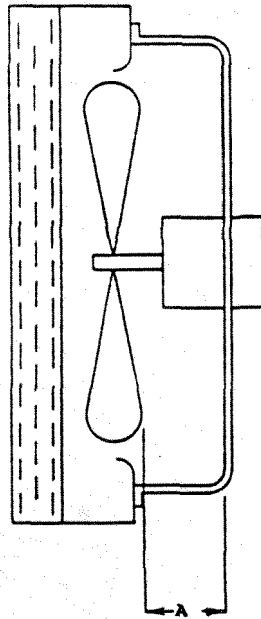

REMOVAL OF THE FAN SHROUD

1. Disconnect all power to unit.
2. Remove the screws holding both grills--one on each side of unit--and remove grills.
3. Remove screws holding fan shroud to condenser and bottom. (9) screws.
4. Unwire condenser fan motor.
5. Slide complete motor, fan blade, and shroud assembly out the left side of the unit.
6. Service motor/fan as needed.
7. Reverse steps to reinstall