



# Waterloo Mfg., Inc.

606 N. Bell Blvd. Cedar Park, Texas 78613



Waterloo Mfg., Inc.

(512) 219-1935 fax; (512) 219-7378 e-mail: jcburch@wlmfg.com

Web Site : WLMFG.COM

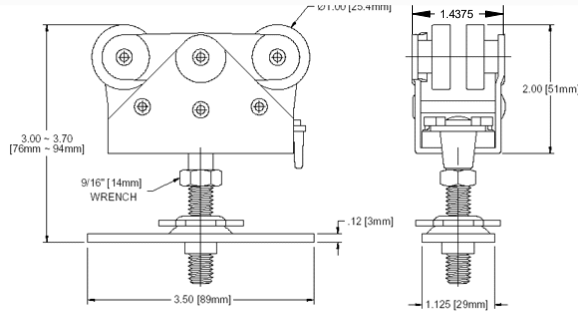

#2020 Hanger for doors up to 400 lbs

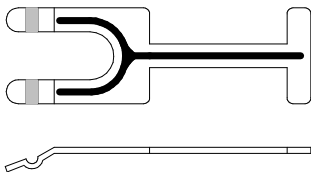

#2056 door catch  
(use with #2055 track stop)

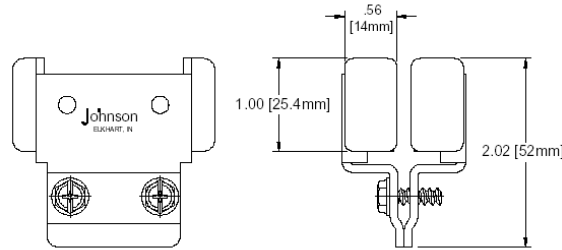
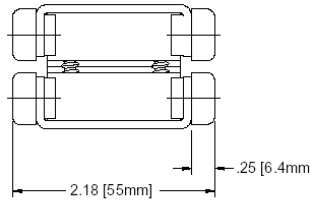

#2055 Track Stop

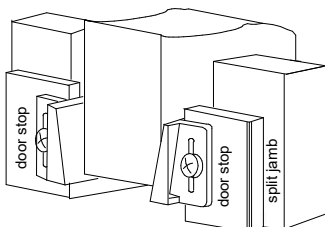
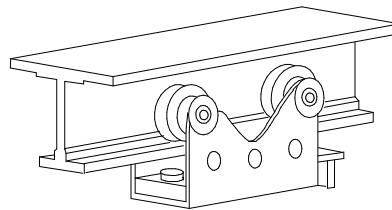
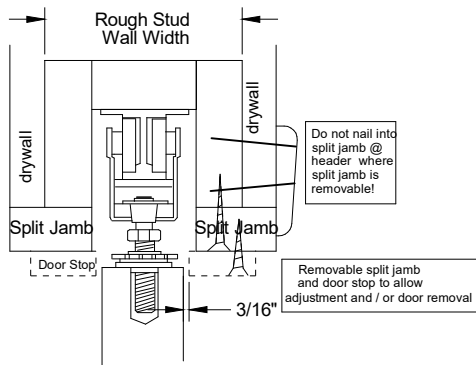

#1550 Door Guides

Pre-drill pilot holes for screws to prevent splitting door stop

