

WWF - 2

AUTOMATIC WIRELESS WATER FILLER

INSTALLATION AND USING INSTRUCTION



⚠ WARNING

THIS EQUIPMENT MUST BE INSTALLED AND SERVICED BY A QUALIFIED TECHNICIAN. IMPROPER INSTALLATION MAY RESULT IN PROPERTY DAMAGE, SERIOUS INJURY OR DEATH. IMPROPER INSTALLATION AND/OR OPERATION WILL VOID THE WARRANTY.

THIS MANUAL CONTAINS IMPORTANT INFORMATION ABOUT THE INSTALLATION, OPERATION AND SAFE USE OF THIS PRODUCT. ONCE THE PRODUCT HAS BEEN INSTALLED THIS MANUAL MUST BE GIVEN TO THE OWNER / OPERATOR OF THIS EQUIPMENT.

General

LODORE WWF-2 Wireless Water Filler keeps your pool topped up easily and automatically. This product senses water level and fill the pool wirelessly and automatically when water level is low.

This product functions wirelessly, so no hose or water pipes are exposed on the ground around your pool. It looks clean and neat from above the pool.

For a pool to function optimally, water levels must be maintained. Evaporation from the sun and wind and even rambunctious pool use will have an impact. If water level drops below the skimmer, the pump can run dry and damage or even burn out the motor. This product maintains pre-set water levels automatically and eliminates the need to keep an eye on the water level.

LODORE WWF-2 Wireless Water Filler fits in any type of existing Pool and Spa.

Specifications

Model	Sensor Length	Height above edge	Minimum water level to warn
WWF-2	7.5inch/19cm	3.5inch/9cm	4inch/10cm to the pool edge
WWF-2AU	10inch/26cm	4-6inch/11-16cm	4-6inch/10-15cm to the pool edge

Controller Unit (for all models)		Sensor Unit (for all models)	
Volts:	110-240VAC to 12VDC	Volts:	3VDC
Freq:	20Mhz	Freq:	20Mhz
Amps:	400mA	Amps:	20mA



Installation

1. Fixing the controller unit on the wall of pool equipment room toward the pool by screwing the unit on the wall (See Figure A). The distance between the controller unit and the sensor shall not exceed 15 meters and avoid any huge barriers such as walls or concrete structure in between. Plug the Transformer into the controller unit Port 1 (See Figure B) .
2. Connect two cables of Valve to the Controller unit Port2 (See Figure B).
3. Connect the output of the Valve with water line of the pool through a PVC Tee; Connect the input of the Valve with the house outdoor faucet through garden hose and check for leaks. (See Figure C)
4. Install the Sensor unit to the pool by screwing the holder on the pool edge so that the Sensor unit submerged into water (See Figure D). MAKE SURE THE THREAD CAP END OUT OF WATER AND THE SENSOR END INTO THE WATER, DO NOT INSTALL IT REVERSELY. Adjust the Sensor to the desired level by simply (gently) moving it up and down. Normally the sensor is at $\frac{1}{2}$ of the skimmer.
5. Twisting off the thread cap to check or change battery. The battery should be changed annually under normal use.

Figure A:

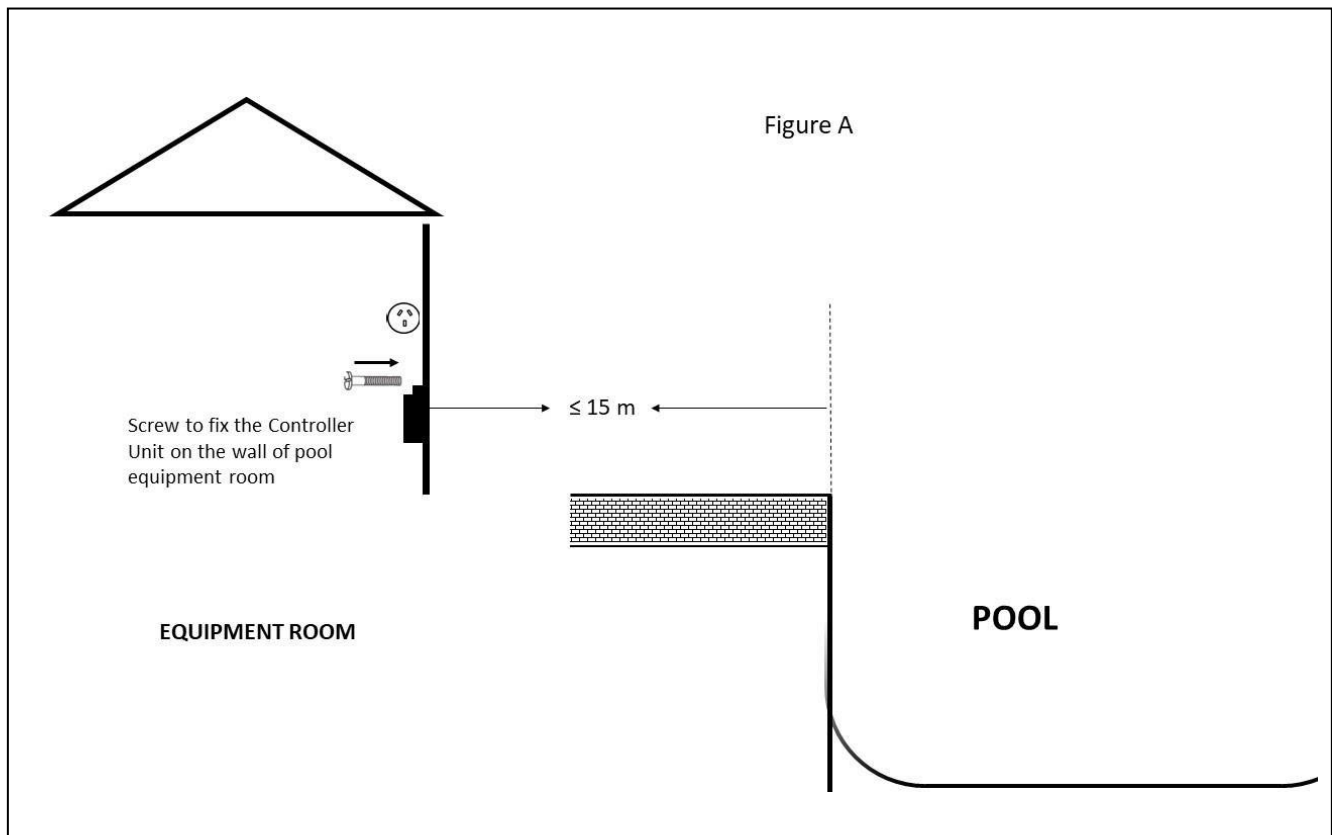

Figure B:

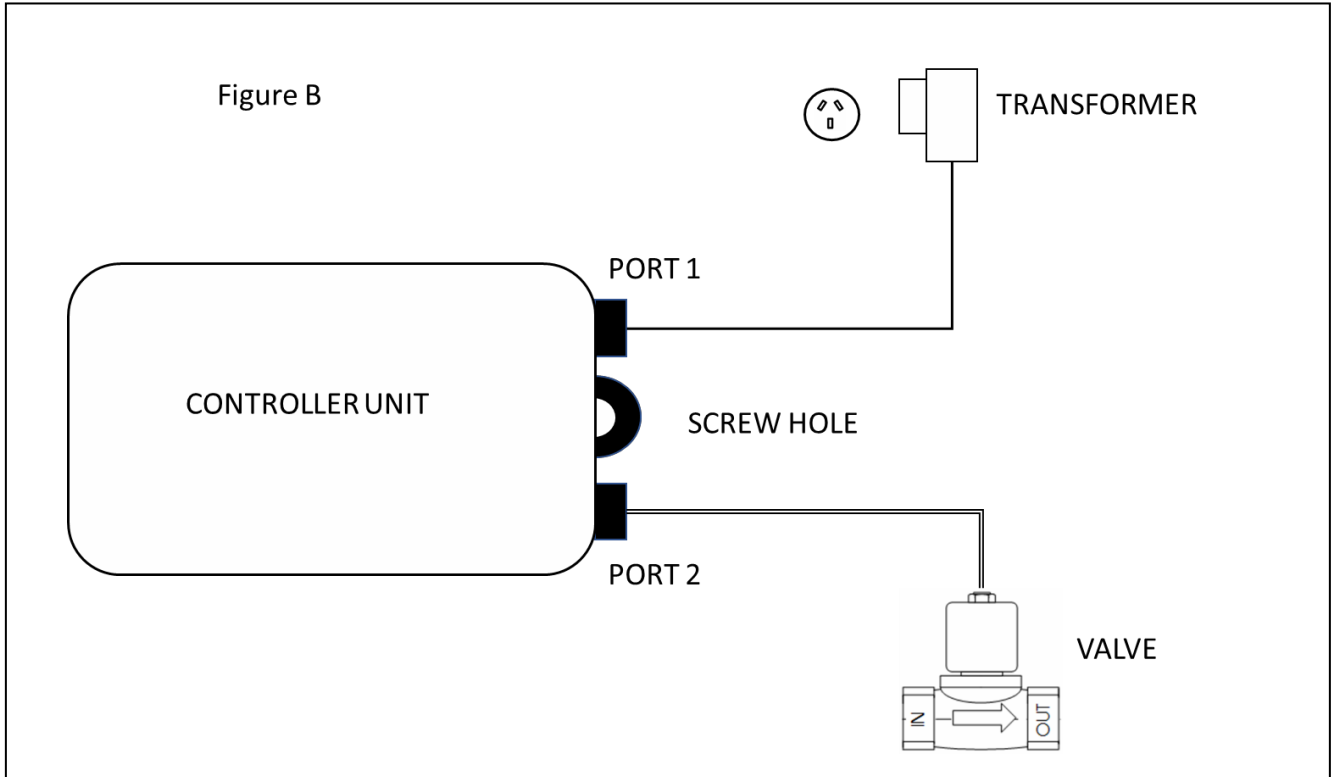

Figure C:

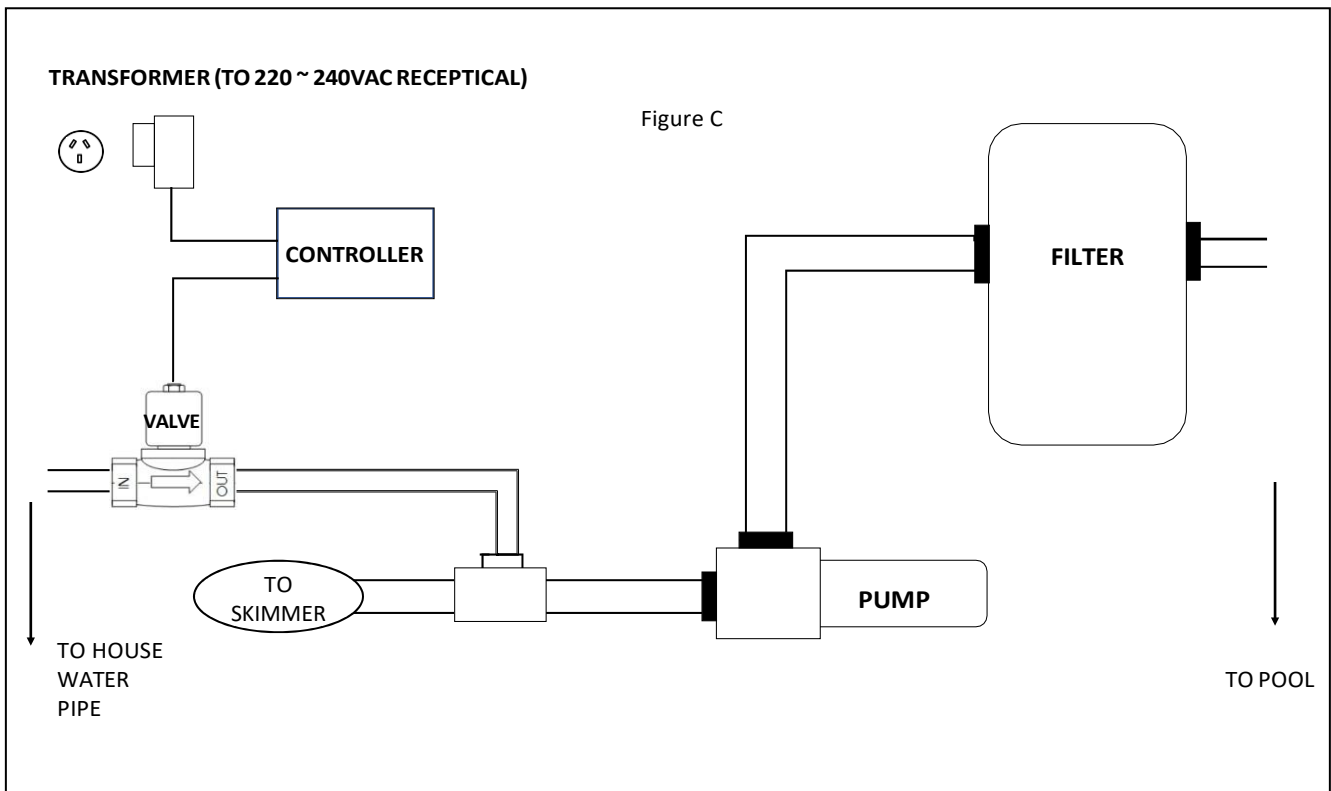
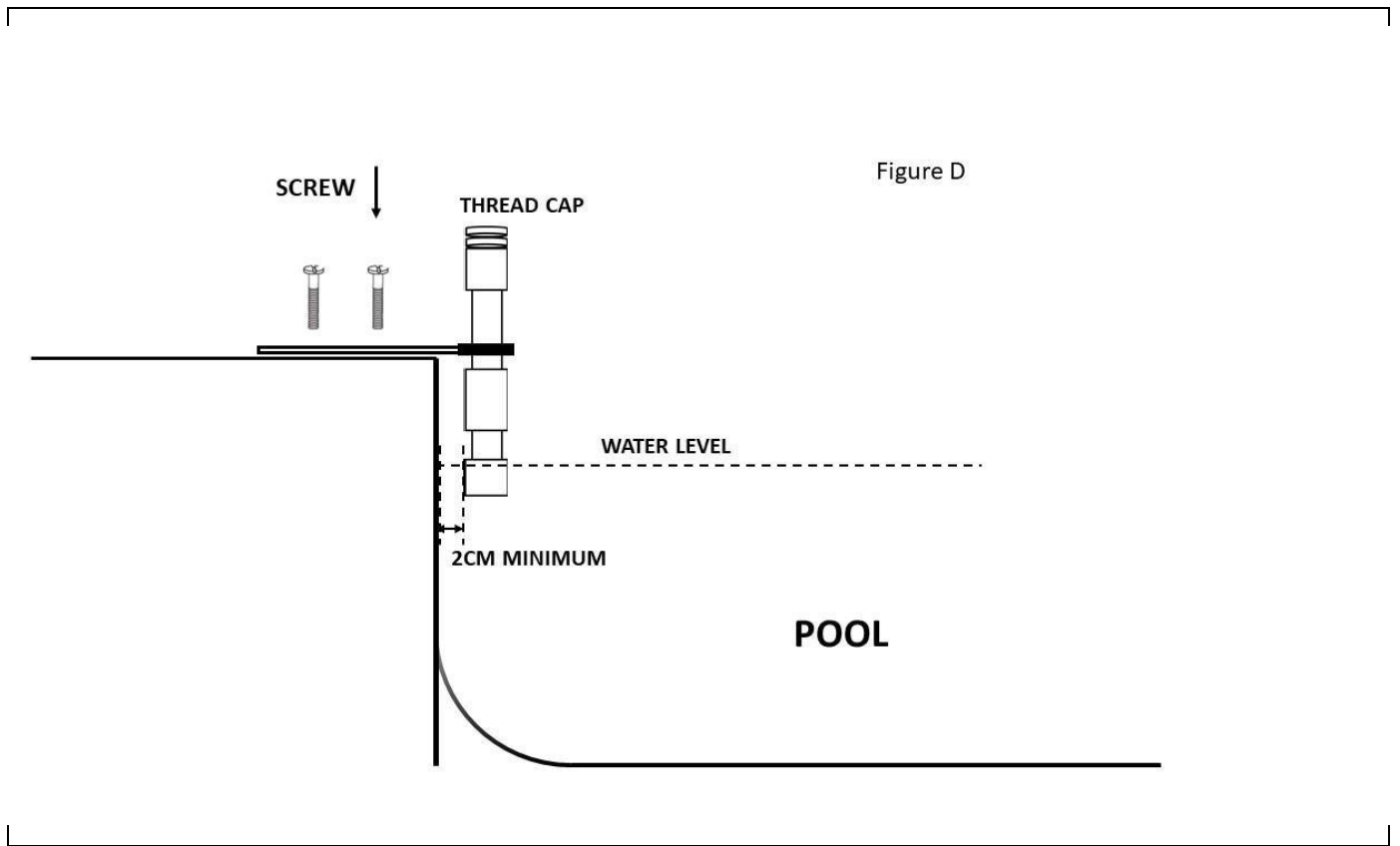

Figure D:



Maintenance

Inspect the Sensor Unit to ensure that the battery is changed annually.

Generally this product does not need service, however, check the place of the Sensor Unit regularly to make sure its position is recommended.

Always be careful and pay attention when using the equipment to avoid over strain of the Sensor Unit.

Warranty

LODORE POOL PRODUCTS as manufacturer warrants each LODORE product unit delivered to the original consumer/purchaser to be free from defects in material and workmanship under the intended normal use as described in LODORE pool product installation and operating instructions enclosed with each unit, for a period of **THREE years** from the date of purchase.

During the warranty period LODORE POOL PRODUCTS agrees to repair or, at its own option, replace the unit or any part of it without charge for labor or parts. This warranty shall not apply if the unit is subjected to misuse, neglect or accident.

Please refer to the detailed LODORE products warranty booklet available at LODORE website www.lodore.ca.

LODORE SWIMMING POOL INDUSTRIES INC.

Canada

232 Laurier Ave West, Ottawa ON, Canada K1A 0G9
Phone: +1 289-477-0233; Fax.: +1 289-477-0300

USA

2152 West 9th Street, Brooklyn NY 11223
Phone: +1 347-395-0309; +1 917-634-3991

Toll Free: +1 844-409-0888

Australia

Phone: +61 2-9159-9477

E-mail:
info.australia@lodore.ca

L'eau D'or
Swimming Pool Products

www.lodore.ca

© 2015 Lodore Swimming Pool Industries Inc.
This document is subject to change without notice.