

Undercounter Freezer Units



Model	Size
EU27X	29" Unit
EU36X	36" Unit
EU47X	47" Unit
EU60X	60" Unit

STANDARD FEATURES

- Stainless steel exterior, aluminum interior and back.
- Refrigeration system keeps food at safe temperatures between -8°F and 0°F
- Self-Closing doors with 90 degree stay-open feature.
- Shelves: Adjustable heavy-duty PVC coated shelves.
- Electronic control system makes it easy to adjust temperature set point and defrost frequency.
- Pre-installed 4" swivel casters with brakes.
- Easy to access condenser coil for cleaning and service.
- Uses R290 refrigerant, which is eco-friendly and more efficient.
- Warranty: Two year parts & labor warranty, and additional three years on compressor.

*Not suitable for installation in a non-commercial or residential applications.

Items	Description	Items	Description
Front, top & sides	Stainless steel	Temperature control	Solid state thermostat/Digital display
Doors	Stainless steel	Approvals	ETL LISTED
External back	Aluminum	Refrigerating system	Capillary tube
Cabinet interior	Aluminum	Refrigerant	R290
Interior floor	Stainless steel	Temperature range	-8°F to 0°F
Insulation	Polyurethane (CFC free)	Evaporator	Powder coated aluminum/copper
Shelves	Heavy duty, PVC coating	Condensing unit	Bottom mounted

CONFORMS TO NSF/ANSI STD 7

EUF27X

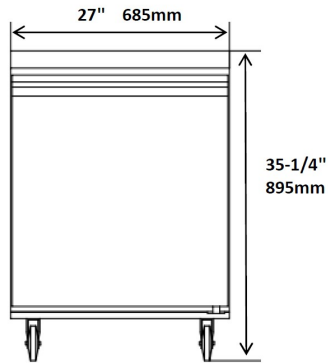

Side View Same For All

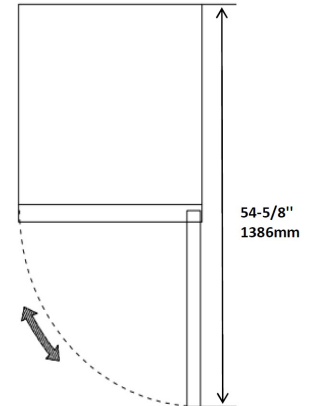
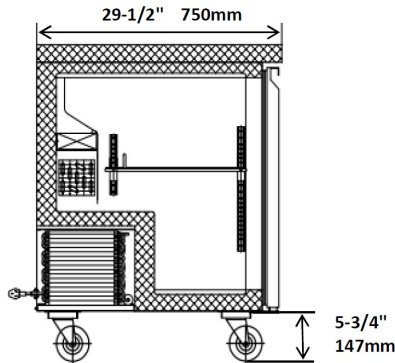

EUF36X

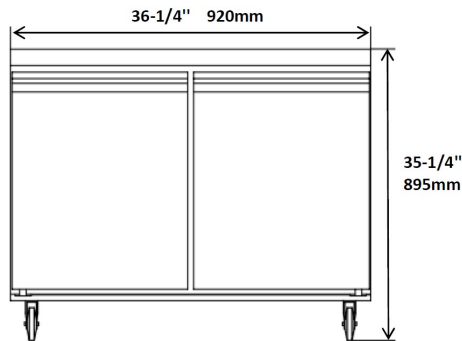

EUF36X & EUF47X

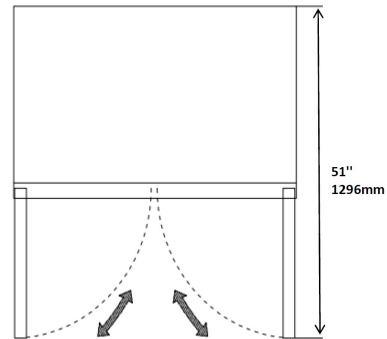

EUF47X

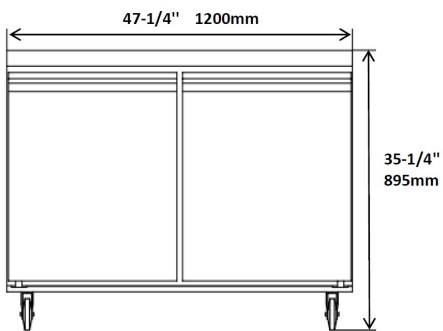

EUF60X

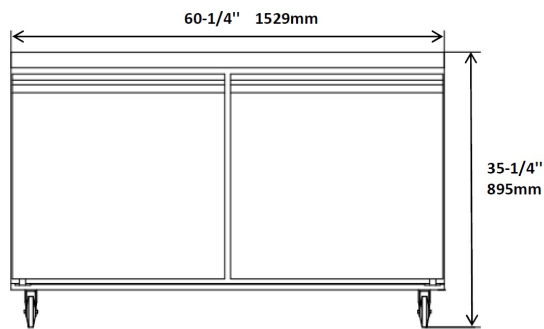

EUF60X

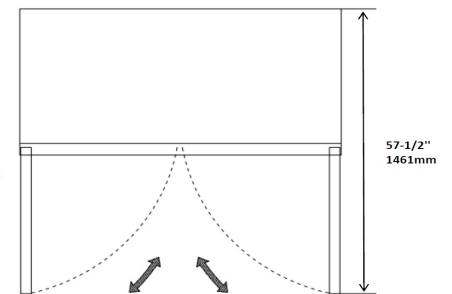

Model	Doors	Shelves	Cabinet Dim (inches)			HP	Voltage	Amps	NEMA Plug	Cord Length	Ship Weight
			L	D	H						
EUF27X	1	1	27	29.5	35.25	1/5	115/60/1	2.1	5-15P	10	233
EUF36X	2	2	36.25	29.5	35.25	1/5	115/60/1	4.5	5-15P	10	245
EUF47X	2	2	47.25	29.5	35.25	1/4	115/60/1	3.1	5-15P	10	312
EUF60X	2	2	60.2	29.5	35.25	1/2	115/60/1	5.0	5-15P	10	323