

2025 BC-1 CLASSIC BY BCROASTERS.COM

THE 2025 BC-1 CLASSIC SAMPLE ROASTER

2025 MARKS THE FIRST YEAR THE BC-1 ROASTER IS BEING OFFERED STANDARD AS A DOUBLE WALL DRUM ROASTER! WHILE YOU CAN STILL CUSTOM ORDER THE BC-1 AS A SINGLE WALL MODEL AND SAVE A COUPLE HUNDRED DOLLARS IT WILL MAINLY BE SOLD AND STOCKED AS A DOUBLE WALL. IT IS ONE OF THE MOST HEAVY DUTY SMALL SAMPLE ROASTERS OFFERED ON THE MARKET AND FOR 2025 WE HAVE ACTUALLY LOWERED THE PRICE! THE BC-1 CAN ROAST SAMPLES AS SMALL AS 3 OUNCES AND ROASTS UP TO ONE POUND. ALSO YOU CAN ROAST 4-5 BATCHES PER HOUR MAKING IT NOT ONLY A GREAT ROASTER FOR A SMALL COFFEE SHOP BUT ALSO A GREAT CHOICE FOR HOME USE. THE BC-1 COMES STANDARD TO RUN ON LPG (PROPANE) BUT CAN BE CONVERTED TO RUN ON NATURAL GAS IF THE CLIENT CHOOSES TO DO SO. ALSO THE BC-1 COMES STANDARD WITH A MAG AIRFLOW GAUGE TO KEEP BETTER TRACK OF AIRFLOW DURING A ROAST. STANDARD BODY COLOR IS BLACK BUT CAN BE CUSTOMER ORDERED IN OTHER COLORS AND MANY HOUSING COLOR CHOICES. IT MAINTAINS ITS 'CLASSIC' LOOK FOR 2025 WHILE MANY OTHER MODELS IN THE BC LINE ARE OFFERING OTHER OPTIONS IN LOOKS.



FEATURES

DRUM TYPE
DATA LOGGING
THERMOCOUPLES
CONTROL PANEL
MAG AIRFLOW
WARRANTY
PARTS AVAILABLE
110V CONVERTER

**SINGLE OR DOUBLE WALL 304SS DRUM
COMPUTER PROFILING VIA USB OR BT
1 K TYPE FOR BT (3MM PROBE)
ALL INFORMATION DISPLAYED ON PANEL
COMES WITH MAG AIRFLOW GAUGE
1 YEAR PARTS & INSTRUCTION
GUARANTEE PARTS AVAILABLE 10YR.
FREE 110V VOLTAGE CONVERTER
INCLUDED.**

BC-1 CLASSIC	GAS TYPE
Batch Size	4oz-1lb.
Roasting Time	9-14 minutes
Production	4-5lb.hr
Heat Source	NG/LPG
Voltage	220V*
Wattage	120W
Drum Motor	25W
Chaff Fan Motor	45W
Cooling Fan Motor	30W
MIXING ARM	N/A
BTU	6400
NG PRESSURE	5-7WC
LPG PRESSURE	MAX. 16WC
Gas Consumption	0.1kg/hr .22lb HR
Roaster Dim.	26x17x24" (LxWxH)
Roaster Weight	62lb.
Package Dimensions	31x25x26"
Package weight	140lb

* RUNS ON 110V WITH INCLUDED VOLTAGE CONVERTER



MANY COLOR OPTIONS

THE BC-1 AIR IS A HEAVY DUTY SAMPLE ROASTER BUILT WITH A CARBON STEEL BODY WITH HIGH TEMPERATURE POWERED COATED IN BLACK, PURPLE, WHITE & RED. THERE ARE SEVERAL HOUSING COLOR OPTIONS AVAILABLE TO CHOOSE FROM. (SEE THE 2025 COLOR CHART)

PRECISE AIRFLOW CONTROL:

PRECISE AIRFLOW CAN BE ACHIEVED USING THE MDDS SYSTEM ALONG WITH THE NEW MAG AIRFLOW GAUGE INCLUDED WITH EVERY ROASTER.

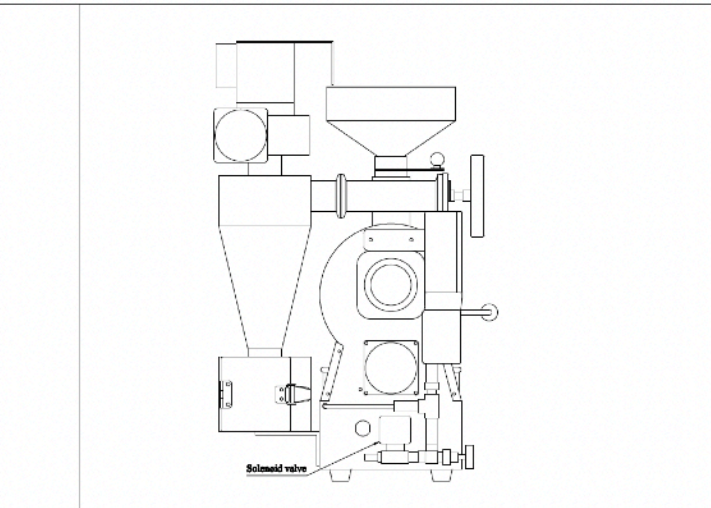
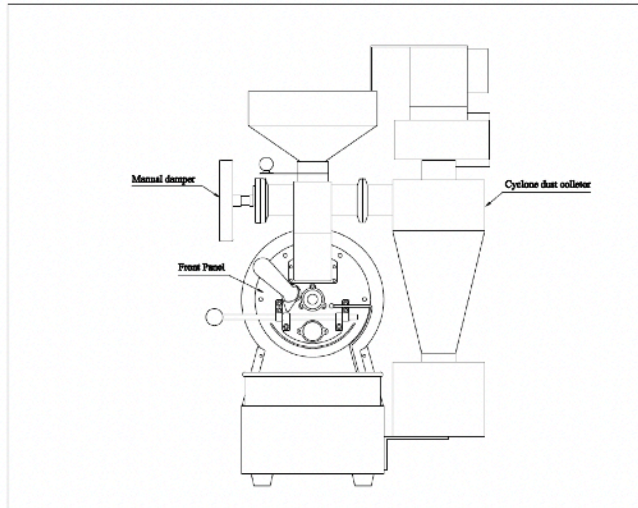

ONLY ONE 3" EXHAUST PIPE RUNS OFF THE CHAFF UNIT TO VENT OUT OF YOUR BUILDING

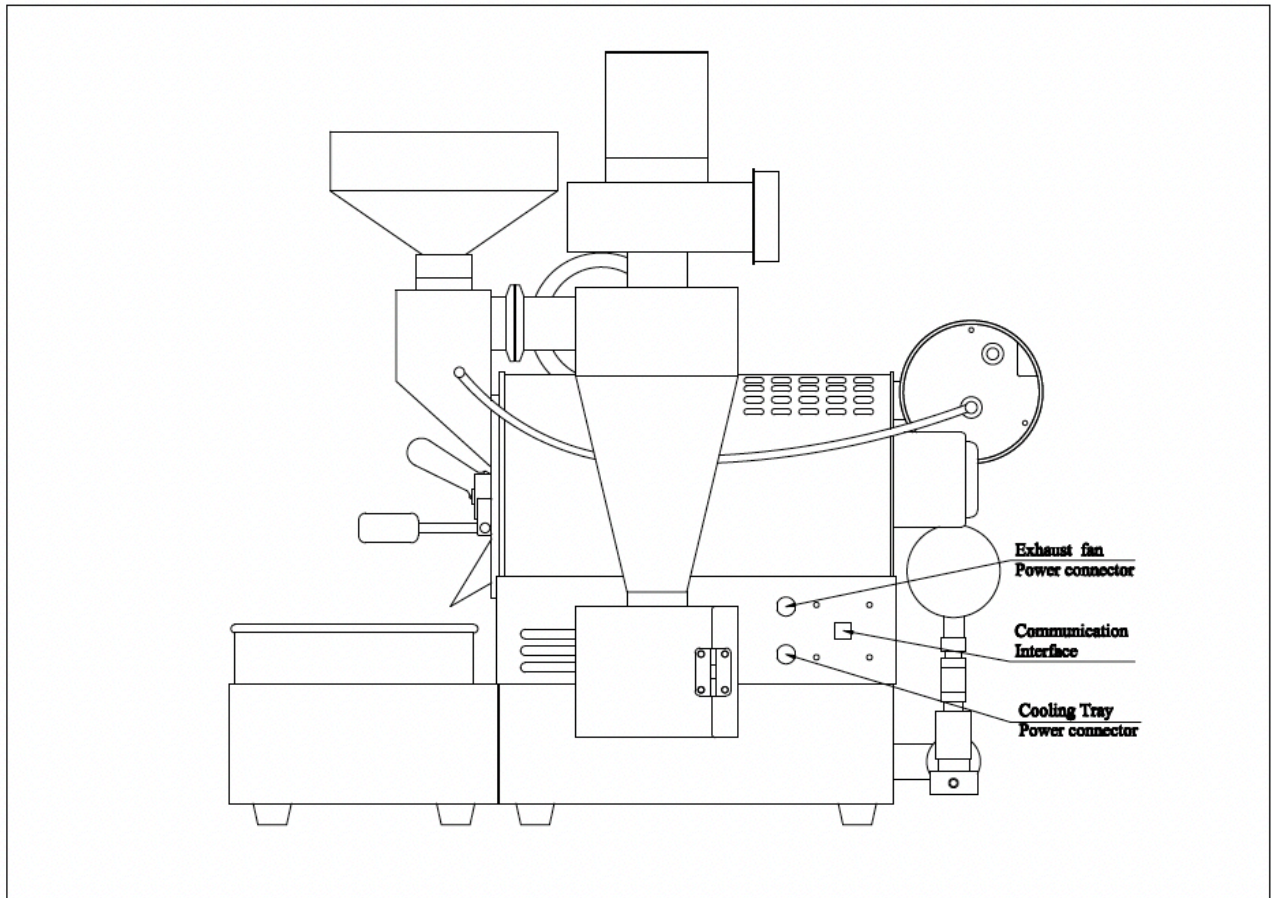
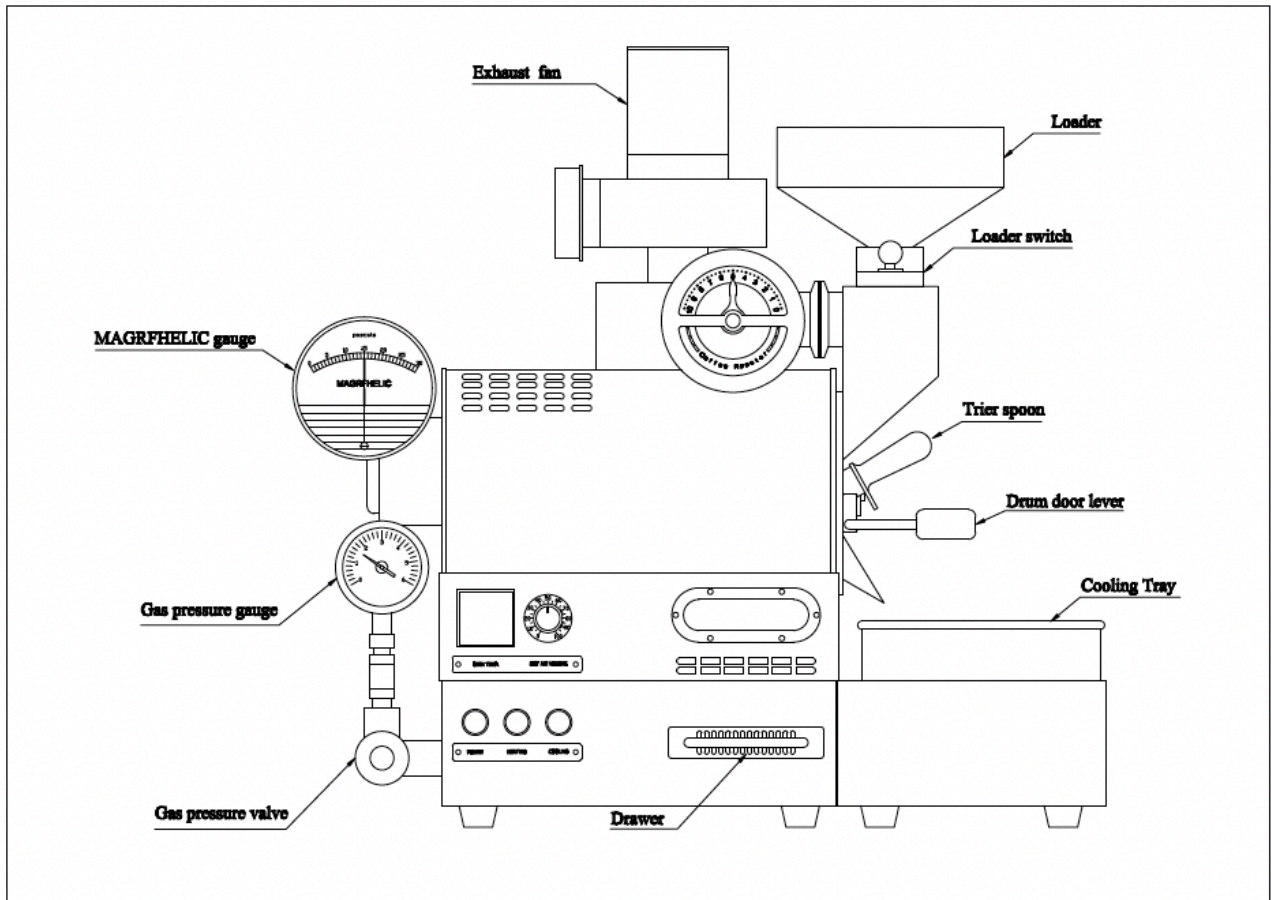

EXHAUST SETUP	
EXHAUST PIPE REQUIREMENTS	POSITIVE PRESSURE EXHAUST VENTING WITH MINIMUM CLEARANCE 12-24" FROM COMBUSTABLE MATERIALS
MAXIMUM VENTING LENGTHS	20' FROM CHAFF UNIT. DEDUCT 3-5' FOR 45-90 DEGREE PIPE ELBOWS. IF YOU MUST VENT AT LONGER LENGTHS CONSULT A LOCAL TECHNICIAN ON USE OF POSSIBLE BOOSTER FANS
MAXIMUM EXHAUST TEMPERATURES	425-475F
CHAFF UNIT HIGH TEMP.	300-350F
COOLING TRAY HIGH TEMP.	200F
DATA LOGGING VIA ARTISAN OR CROPSTER	BUILT IN DATA LOGGER ATTACHES TO COMPUTER (PC OR MAC) VIA USB OR BLUETOOTH
K TYPE THERMOCOUPLE	BT PROBE ONLY.3MM THICK PROBES
MANUFACTURED IN CHINA FOR BC ROASTERS	CUSTOM BUILT FOR BC SPECS IN USA AND OVER 200 LANDS



BC-1 AIR COMMERCIAL COFFEE ROASTER

- *TABLE TOP MODEL
- *DIRECT CONNECT CHAFF UNIT FOR SMALLER FOOTPRINT
- *CHOICE GAS MODELS

SIZE (LxWxH)	26x17x24" (LxWxH) (INCLUDES DIRECT CONNECT CHAFF UNIT IN MEASUREMENT)
WEIGHT	62lb.
MINIMUM CLEARANCE FROM COMBUSTABLE MATERIALS	12-24"
ROASTING CAPACITY	3 OZ UP TO 1LB.
ROAST TIME & ROASTS PER HOUR	9-14 MINUTES (4-5 ROASTS PER HOUR)
DRUM INFORMATION	<p>SW DRUM: 3MM SUPERIOR 304SS CONTAINS 18% CHROMIUM AND 8% NICKEL</p> <p>DW DRUM: HAS TWO LAYERS OF 304SS THAT ARE EACH 2MM WITH A 2MM AIR CUSHION BETWEEN BOTH LAYERS. TOTAL THICKNESS 6MM</p>
ELECTRIC STATS:	<p>GAS MODEL: SINGLE PHASE 220V 50/60HZ 110W REQUIRES STANDARD 15A BREAKER. <u>A FREE 110 VOLTAGE CONVERTER IS PROVIDED WITH EACH ROASTER TO RUN ON A TYPICAL 15A 110-120 BREAKER IN USA & CANADA</u></p>
ELECTRICAL PLUG TYPE	GAS MODELS: 20A 250V 3 WIRE NEMA 6-20P
FUEL CHOICES ON GAS MODELS	LPG GAS STANDARD WITH MODELS. NATURAL GAS CONVERSION KITS OFFERED FOR CUSTOMER INSTALLATION ONLY.
BURNER INFORMATION ON GAS MODELS	2 HIGH EFFICIENCY BURNERS PROVIDE
BTU REQUIREMENTS	7500-10,000 BTU MINIMUM REQUIRED FOR NG LINE
GAS PRESSURE	<p>LPG: 12-16WC (3-4KPA) MARSHALL 1912/197 REGULATOR RECOMMENDED</p> <p>NG: 7-14WC</p>

FOR MORE INFORMATION SEE:

BCROASTERS.COM

[HTTP://WWW.BUCKEYECOFFEE.COM/BC-COFFEE-ROASTERS.HTML](http://WWW.BUCKEYECOFFEE.COM/BC-COFFEE-ROASTERS.HTML)



BC ROASTERS
BUCKEYE, ARIZONA 85326
TONOPAH, ARIZONA 85354

TOLL FREE: 844.522.6333
INFO@BUCKEYECOFFEE.COM
INFO@BCROASTERS.COM